

## Getting to Know Your Smart Air Fryer Toaster Oven

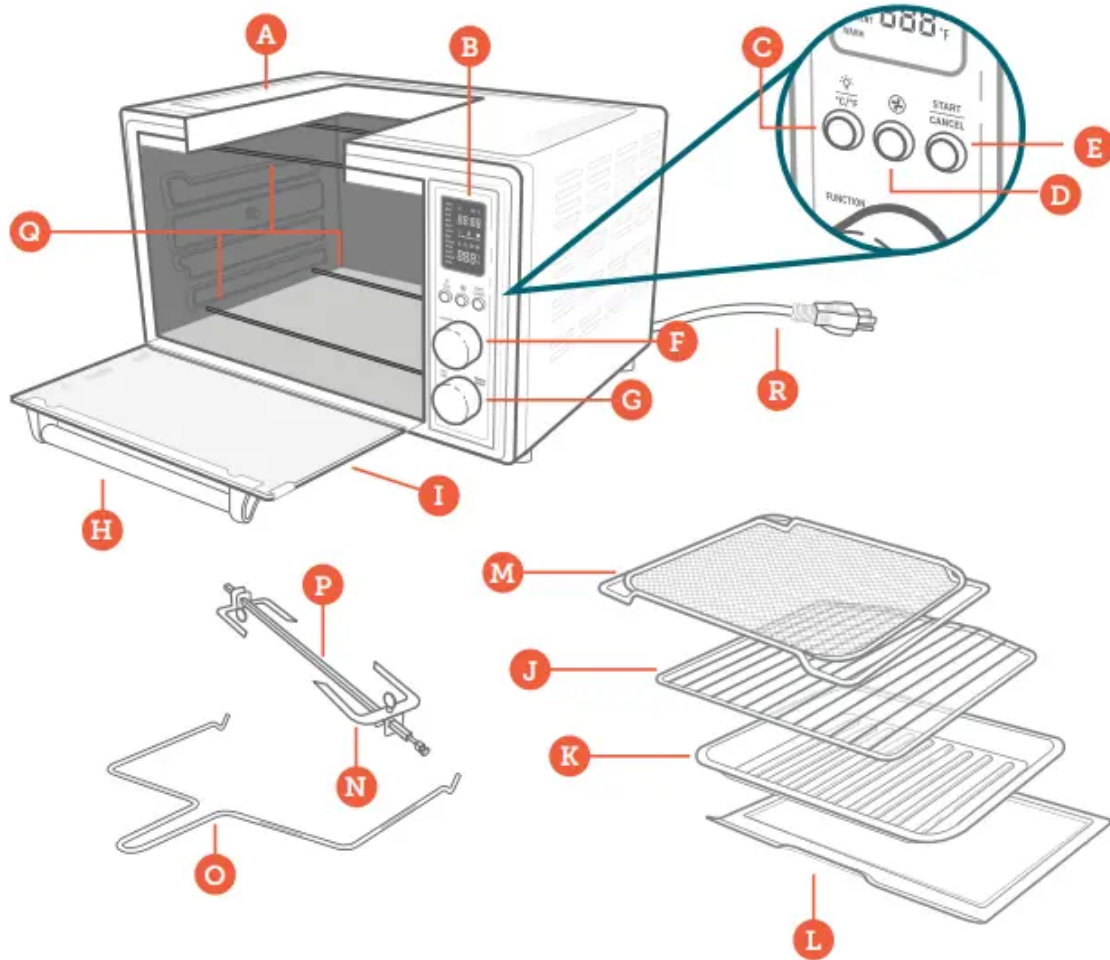

- |                               |                          |                             |
|-------------------------------|--------------------------|-----------------------------|
| <b>A.</b> Housing             | <b>G.</b> TIME/TEMP Knob | <b>M.</b> Fry Basket        |
| <b>B.</b> LED Display         | <b>H.</b> Handle         | <b>N.</b> Rotisserie Forks  |
| <b>C.</b> Light/Unit Button   | <b>I.</b> Door           | <b>O.</b> Rotisserie Handle |
| <b>D.</b> Fan Button          | <b>J.</b> Wire Rack      | <b>P.</b> Rotisserie Shaft  |
| <b>E.</b> START/CANCEL Button | <b>K.</b> Food Tray      | <b>Q.</b> Heating Elements  |
| <b>F.</b> FUNCTION Knob       | <b>L.</b> Crumb Tray     | <b>R.</b> Power Cord        |

# DISPLAY

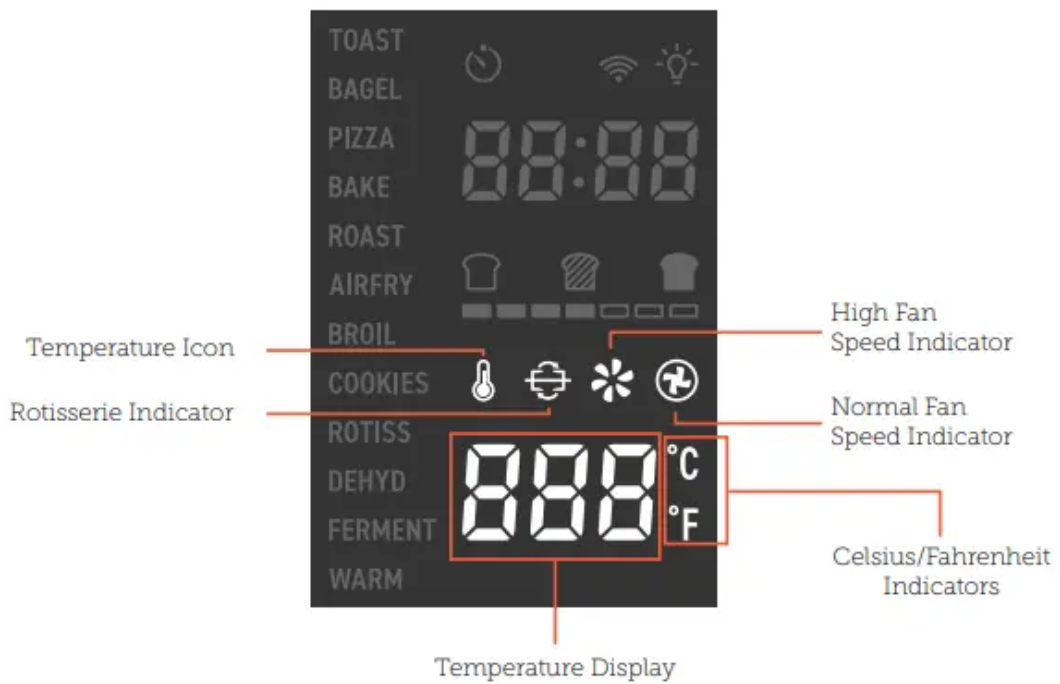
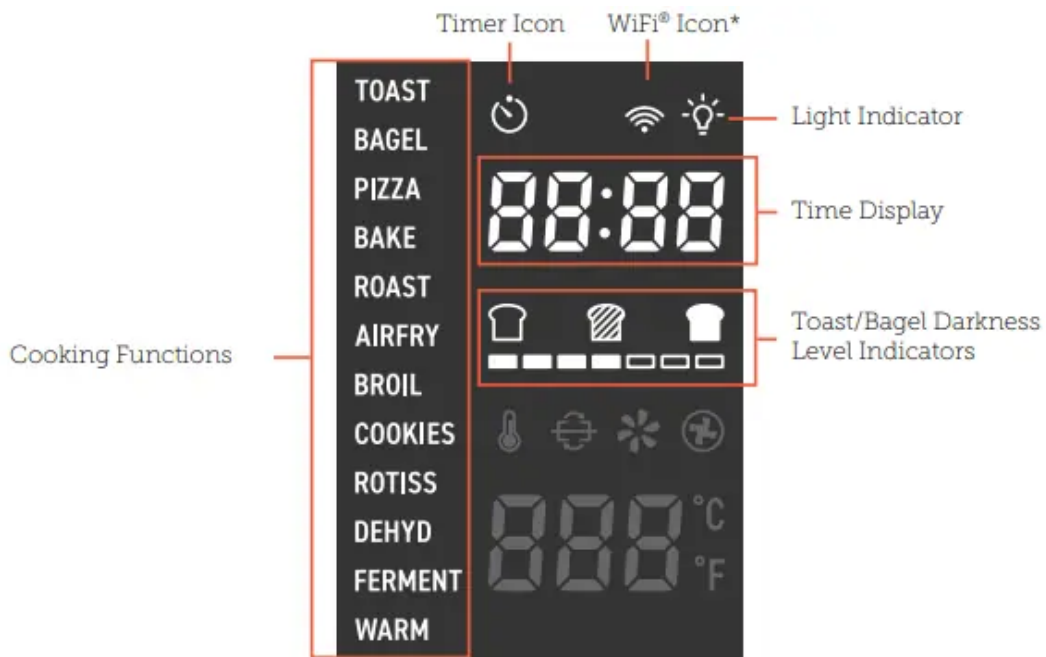



# CONTROLS

## Light/Unit Button

- Turns the interior light on/off  will show on the display.

- The interior light will turn on automatically when there is 1 minute left of cooking time. Press to turn the light back off.
- Press and hold to switch temperature units between Fahrenheit and Celsius.

## Fan Button

- Cycles through fan speeds: normal, high, and off.
- The fan can be used for all cooking functions except Toast and Bagel. The fan is automatically set during Air Fry and Dehydrate.
- Press and hold  until  starts blinking. This will let you pair your toaster oven with the VeSync app

## START/CANCEL Button

- Starts or cancels a cooking function.
- If preheating, cancels preheating and starts the cooking function.
- Blinks when the oven has finished preheating. Press the button again to start the cooking function.
- Lights up when the oven is heating

## FUNCTION Knob

- Turn the knob to choose a cooking function. The selected function will blink on the display

## TIME/TEMP Knob

- Turn the knob to change time/ temperature. Turn clockwise to increase, and counterclockwise to decrease.
- Press the knob to switch between controlling time and temperature. By default, the knob will control time.
- Time will adjust in increments of +/- 1, 5, 10, or 15 minutes (see chart).
- Temperature will adjust in increments of +/- 5°F.
- After a time or temperature setting is selected, the number will flash 5 times on the display before the setting is confirmed.
- Display On/Off: Press and hold the knob until the display turns on/off.

### Time Increment Chart

Toast, Bagel, Pizza, Bake, Roast, Air Fry, Broil, Cookies, Rotisserie, Warm
-----------------------------------------------------------------------------

Below 60 minutes	+/- 1-minute increments
1–2 hours	+/- 5-minute increments
2–3 hours	+/- 10-minute increments
Above 3 hours	+/- 15-minute increments

Dehydrate, Ferment

All times	+/- 30-minute increments
-----------	--------------------------

## BEFORE FIRST USE

### Setting Up

1. Remove all packaging around and inside the oven.
2. Place on a stable, level, heat-resistant surface, away from anything that can be damaged by heat.
3. Wash all accessories and clean the oven's interior. Dry and place accessories back in oven.

### Test Run

A test run will help you become familiar with your oven, make sure it's working correctly, and clean it of possible residues in the process.

1. Make sure there is no food or packaging in the oven and plug it in.
2. Turn the FUNCTION knob to "TOAST" and turn the TIME/TEMP knob to Level 7.
3. Press START/CANCEL to begin heating. The button will light up, and the display will show the timer counting down.
4. The oven will stop heating and beep several times when finished.

## VeSync App Setup

Note: Due to ongoing updates and improvements, the VeSync app may be slightly different than shown in the manual. In case of any differences, follow the in-app instructions

1. To download the VeSync app, scan the QR code or search “VeSync” in the Apple App



Store® or Google Play Store.

2. Open the VeSync app. If you already have an account, tap Log In. To create a new account, tap Sign Up
3. Turn on Bluetooth® on your phone.
4. Tap + and select your smart air fryer toaster oven.
5. Follow the in-app instructions to finish setting up your toaster oven.

## COOKING WITH YOUR SMART AIR FRYER TOASTER OVEN

Note: You can use the VeSync app to control your smart air fryer toaster oven, follow in-app recipes, and more. For full instructions, see Using the App

### CAUTION:

- The outer surface of the oven, including the oven door, is hot during and after use. Temperature may be over 212°F / 100°C. Do not touch hot surfaces. Use handle.
- Always use heat-resistant gloves, pads, or oven mitts when handling hot materials, and when placing items in or removing items from the oven.

Note: For easier cleanup, always leave the crumb tray at the bottom of the oven when cooking. The tray should be beneath the heating elements

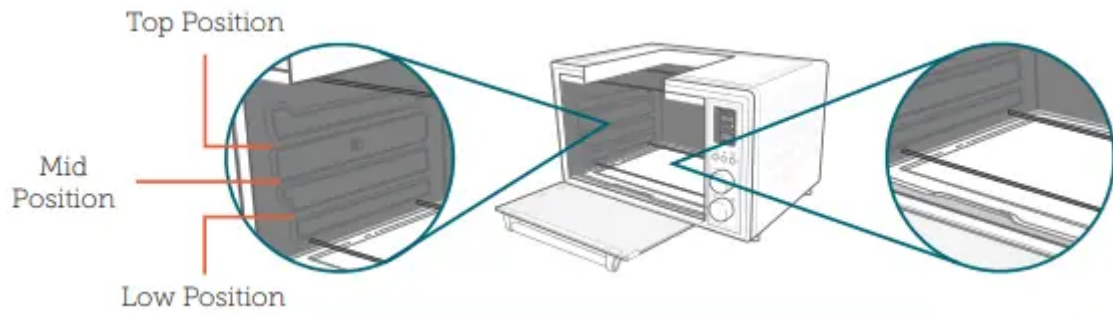

## Cooking Functions Quick Reference Chart

Name	Use	Suggested Accessory & Position	Range
Toast <b>"TOAST"</b>	<ul style="list-style-type: none"> <li>• Toast or brown bread</li> <li>• Manually preheat oven</li> <li>• Defrost food</li> </ul>	Wire rack at mid position	<ul style="list-style-type: none"> <li>• Darkness Level 1-7</li> <li>• Temperature is automatic</li> </ul>
Bagel <b>"BAGEL"</b>	<ul style="list-style-type: none"> <li>• Toast bagels or crumpets</li> <li>• Toast any bread that requires one side to be more toasted than the other</li> <li>• When toasting bagels, place the inside (cut side) facing upwards. The top side will be toasted more than the bottom side</li> </ul>	Wire rack at mid position	<ul style="list-style-type: none"> <li>• Darkness Level 1-7</li> <li>• Temperature is automatic</li> </ul>
Pizza <b>"PIZZA"</b>	<ul style="list-style-type: none"> <li>• Melt and brown cheese and toppings while crisping crust</li> <li>• Includes automatic preheat</li> </ul>	Wire rack at mid position	<ul style="list-style-type: none"> <li>• 150°-450°F / 65°-232°C</li> <li>• 1 min-6 hr</li> </ul>

Bake <b>"BAKE"</b>	<ul style="list-style-type: none"> <li>• Cook foods evenly throughout</li> <li>• Bake cakes, muffins, pastries</li> <li>• Includes automatic preheat</li> </ul>	Food tray or wire rack at low position	<ul style="list-style-type: none"> <li>• 150°–450°F / 65°–232°C</li> <li>• 1 min–6 hr</li> </ul>
Roast <b>"ROAST"</b>	<ul style="list-style-type: none"> <li>• Cook a variety of meats and poultry</li> <li>• Food will be tender and juicy on the inside and well-roasted on the outside.</li> <li>• Includes automatic preheat</li> </ul>	Food tray at low position	<ul style="list-style-type: none"> <li>• 150°–400°F / 65°–205°C</li> <li>• 1 min–6 hr</li> </ul>
Air Fry <b>"AIRFRY"</b>	<ul style="list-style-type: none"> <li>• Cooks using intense heat and maximized airflow</li> <li>• Cook food such as french fries and chicken wings</li> <li>• Includes automatic preheat</li> </ul>	Fry basket at mid position	<ul style="list-style-type: none"> <li>• 150°–400°F / 65°–205°C</li> <li>• 1 min–6 hr</li> </ul>
Broil <b>"BROIL"</b>	<ul style="list-style-type: none"> <li>• Cook open-faced sandwiches, thin cuts of meat (such as bacon), poultry, fish, sausages, and vegetables</li> <li>• Brown the tops of casseroles, gratins, and desserts</li> <li>• Includes automatic preheat</li> </ul>	Food tray at top position	<ul style="list-style-type: none"> <li>• 150°–450°F / 65°–232°C</li> <li>• 1 min–6 hr</li> </ul>
Cookies <b>"COOKIES"</b>	<ul style="list-style-type: none"> <li>• Bake cookies and other baked treats</li> <li>• Includes automatic preheat</li> </ul>	Food tray or wire rack at mid position	<ul style="list-style-type: none"> <li>• 150°–450°F / 65°–232°C</li> <li>• 1 min–6 hr</li> </ul>
Rotisserie <b>"ROTISS"</b>	<ul style="list-style-type: none"> <li>• Cook rotating roasts, such as a whole chicken</li> </ul>	Rotisserie slots  <b>Note:</b> Also requires food tray at low position to collect drippings.	<ul style="list-style-type: none"> <li>• 150°–400°F / 65°–205°C</li> <li>• 1 min–6 hr</li> </ul>
Dehydrate <b>"DEHYD"</b>	<ul style="list-style-type: none"> <li>• Evenly dry out foods without cooking</li> <li>• Dry fruit or vegetable chips</li> </ul>	Wire rack or fry basket at mid position	<ul style="list-style-type: none"> <li>• 100°–180°F / 38°–80°C</li> <li>• 30 min–24 hr</li> </ul>
Ferment <b>"FERMENT"</b>	<ul style="list-style-type: none"> <li>• Precisely hold low temperatures</li> <li>• Proof bread, rolls, pizza, and dough</li> <li>• Make yogurt</li> </ul>	Food tray or wire rack at low position	<ul style="list-style-type: none"> <li>• 80°–110°F / 27°–43°C</li> <li>• 30 min–12 hr</li> </ul>
Warm <b>"WARM"</b>	<ul style="list-style-type: none"> <li>• Keep food warm at the recommended temperature to prevent bacterial growth (160°F / 70°C or above)</li> </ul>	Food tray or wire rack at low position	<ul style="list-style-type: none"> <li>• 140°–230°F / 60°–100°C</li> <li>• 1 min–12 hr</li> </ul>



## Convection Fan

- The fan circulates hot air in the oven for faster and more even cooking. Use the high fan speed (super convection) for crispier results, and for air frying. You can turn the fan on and off at any time during cooking.
- Note: The fan cannot be used for the Toast or Bagel functions. Fan speed is set automatically for the Air Fry and Dehydrate functions.

## Automatic Preheat

Pizza, Bake, Roast, Broil, Cookies, and Air Fry all use automatic preheat.

1. When you start the cooking function by pressing START/CANCEL, preheating will start automatically. The START/CANCEL button will light up, and the display will show “**PrE**”

- Pressing START/CANCEL again during preheating will cancel preheating and immediately start cooking



2. When preheating is finished, the oven will beep several times and the display will flash. This will repeat once every minute. The START/CANCEL button will blink continuously until pressed again.

- After 10 minutes of inactivity, the cooking function will cancel, the oven will stop heating, and the display will reset.

3. Press START/CANCEL to begin cooking. The button will light up, and the display will show the timer counting down.

- Preheating times vary based on the temperature setting (see chart)

Setting Temperature	Automatic Preheat Time
300°F / 148°C and below	2–4 min
325°F / 163°C	3–5 min
350°F / 178°C	4–6 min
400°F / 205°C and above	6–8 min

## Toast Function (“TOAST”)



- This function browns the outside of your bread while keeping the inside soft. Also ideal for English muffins and frozen waffles.
- Can be used to manually preheat the oven or defrost food. Use Level 4 or higher

Heating Elements: Top and bottom heating elements cycle on and off.

Rack Position: Mid

1. Place up to 6 slices of bread on the wire rack. Insert the wire rack at mid position and close the oven door.
2. Turn the FUNCTION knob to “TOAST”, which will blink on the display.
3. Optionally, customize the darkness level. You can only do this before cooking starts.
  - Turn the TIME/TEMP knob to adjust the darkness level between 1–7. The bars underneath the toast icons indicate the darkness level.
  - Use 1–2 for a light toast, 3–5 for a medium toast, and 6–7 for a dark toast.

Note:

- When setting the darkness level, consider the type, thickness, and freshness of the bread.

- Try lighter settings for raisin toast, white bread, and thinly-sliced bread.
- Try darker settings for rye, whole wheat, heavier-textured bread, and fresh bread.
- Time and temperature are set automatically. Time increases with darkness level.

Temperature is set to the highest level (450°F / 232°C). The display will show “HI”.

4. Press START/CANCEL to begin. The button will light up, and the display will show the timer counting down.

5. The oven will stop heating and beep several times when finished.

## Bagel Function (“BAGEL”)



This function crisps the inside of a cut bagel while lightly toasting the outside.

Also ideal for toasting crumpets or thick-sliced specialty breads which require one side to be more toasted than the other.

Heating Elements: Top heating elements cycle on and off, and bottom heating elements are half on and half off.

Rack Position: Mid

1. Slice the bagel in half. Center the halves on the wire rack. Insert the wire rack at mid position and close the oven door
2. Turn the FUNCTION knob to “BAGEL”, which will blink on the display.
3. Optionally, customize the darkness level. You can only do this before cooking starts.
  - Turn the TIME/TEMP knob to adjust the darkness level between 1–7. The bars underneath the toast icons indicate the darkness level.
  - Use 1–2 for a light toast, 3–5 for a medium toast, and 6–7 for a dark toast
4. Press START/CANCEL to begin. The button will light up, and the display will show the timer counting down.
5. The oven will stop heating and beep several times when finished.

## Pizza Function (“PIZZA”)



This function melts and browns cheese and toppings, while crisping crust.

Heating Elements: Top and bottom heating elements cycle on and off.

Rack Position: Mid

1. Insert wire rack at mid position and close the oven door.
2. Turn the FUNCTION knob to “PIZZA”, which will blink on the display.
3. Optionally, customize the temperature and time. You can do this anytime during cooking (except during preheating).
  - Turn the TIME/TEMP knob to adjust the time between 1 min–6 hr.
  - Press the TIME/TEMP knob once to control temperature. Turn the knob to adjust the temperature between 150°–450°F / 65°–232°C.
4. . Press START/CANCEL to begin. Preheating will start automatically. The START/CANCEL button will light up, and the display will show “*PrE*”.
5. When preheating is finished, the oven will beep several times, the display will flash, and the START/CANCEL button will blink continuously.
6. Remove any cardboard, plastic, paper, or other flammable materials. Place pizza on a pan, and place the pan on the wire rack. Close the oven door.
7. Press START/CANCEL to begin cooking. The button will light up, and the display will show the timer counting down.
8. The oven will stop heating and beep several times when finished.

## Bake Function (“BAKE”)



This function cooks food evenly throughout. Ideal for baking cakes, muffins, brownies, and pastries. Also ideal for cooking prepackaged frozen meals, including lasagna and pot pies.

Heating Elements: Top and bottom heating elements cycle on and off.

Rack Position: Low

1. If using the wire rack, insert at low position and close the oven door.
2. Turn the FUNCTION knob to “BAKE”, which will blink on the display.
3. Optionally, customize the temperature and time. You can do this anytime during cooking (except during preheating).
  - Turn the TIME/TEMP knob to adjust the time between 1 min–6 hr.
  - Press the TIME/TEMP knob once to control temperature. Turn the knob to adjust the temperature between 150°–450°F / 65°–232°C.
4. Press START/CANCEL to begin. Preheating will start automatically. The START/CANCEL button will light up, and the display will show “PrE”.
5. When preheating is finished, the oven will beep several times, the display will flash, and the START/CANCEL button will blink continuously.
6. Place food inside the oven. If using the food tray, insert at low position. Close the oven door
7. Press START/CANCEL to begin cooking. The button will light up, and the display will show the timer counting down.
8. The oven will stop heating and beep several times when finished.

## Roast Function (“ROAST”)



This function is ideal for cooking a variety of meats and poultry. Food will be tender and juicy on the inside and well-roasted on the outside.

Heating Elements: Top and bottom heating elements cycle on and off.

Rack Position: Low

1. If using the wire rack, insert at low position and close the oven door.
2. Turn the FUNCTION knob to “ROAST”, which will blink on the display.
3. Optionally, customize the temperature and time. You can do this anytime during cooking (except during preheating).
  - Turn the TIME/TEMP knob to adjust the time between 1 min–6 hr.
  - Press the TIME/TEMP knob once to control temperature. Turn the knob to adjust the temperature between 150°–400°F / 65°–205°C.
4. Press START/CANCEL to begin. Preheating will start automatically. The START/CANCEL button will light up, and the display will show “PrE”
5. When preheating completes, the oven will beep several times, the display will flash, and the START/CANCEL button will blink continuously.
6. Place food inside the oven. If using the food tray, insert at low position. Close the oven door.
7. Press START/CANCEL to begin cooking. The button will light up, and the display will show the timer counting down.
8. The oven will stop heating and beep several times when finished.

## Air Fry Function (“AIRFRY”)



This function is ideal for cooking a variety of food, including french fries and chicken wings. Uses intense heat and maximized airflow.

Heating Elements: Top, bottom, and side heating elements cycle on and off.

Note: Side heating elements are on the right side of the oven, and are not visible.

Rack Position: Mid

1. Turn the FUNCTION knob to “AIRFRY”, which will blink on the display.
2. Optionally, customize the temperature and time. You can do this anytime during cooking (except during preheating).
  - Turn the TIME/TEMP knob to adjust the time between 1 min–6 hr.
  - Press the TIME/TEMP knob once to control temperature. Turn the knob to adjust the temperature between 150°–400°F / 65°–205°C.
3. Press START/CANCEL to begin. Preheating will start automatically. The START/CANCEL button will light up, and the display will show “*PrE*”.
4. When preheating completes, the oven will beep several times, the display will flash, and the START/CANCEL button will blink continuously.
5. Place food in the fry basket. a. When air frying fatty foods (such as chicken wings), use the food tray instead to prevent oil dripping. Discard excess oil between batches.
6. Insert at mid position and close the oven door.
7. Press START/CANCEL to begin cooking. The button will light up, and the display will show the timer counting down.
8. The oven will stop heating and beep several times when finished.

## Broil Function (“BROIL”)



This function is ideal for cooking openfaced sandwiches, thin cuts of meat (such as bacon), poultry, fish, sausages, and vegetables.

Can also be used to brown the tops of casseroles, gratins, and desserts.

Heating Elements: Top heating elements stay on for 5 min, then cycle on and off. Bottom heating elements are half on and half off.

Rack Position: Top

1. Turn the FUNCTION knob to “BROIL”, which will blink on the display.
2. Optionally, customize the temperature and time. You can do this anytime during cooking (except during preheating).
  - Turn the TIME/TEMP knob to adjust the time between 1 min–6 hr.
  - Press the TIME/TEMP knob once to control temperature. Turn the knob to adjust the temperature between 150°–450°F / 65°–232°C.
3. Press START/CANCEL to begin. Preheating will start automatically. The START/CANCEL button will light up, and the display will show “PrE”.
4. When preheating completes, the oven will beep several times, the display will flash, and the START/CANCEL button will blink continuously.
5. Place food on the food tray.
  - Optionally, lightly grease the enamel food tray or line with foil to prevent food from sticking.
  - Use extreme caution when using foil, and always fit foil as securely as possible. To avoid overheating and risk of fire, make sure foil does not contact the heating elements.

6. Insert the food tray at top position and close the oven door.
  - Insert at mid position instead for:
    - Bulky foods that may touch the upper heating elements
    - Thicker foods such as burger patties
    - Marinated foods such as chicken wings
    - Foods requiring a gentler broil
7. Press START/CANCEL to begin cooking. The button will light up, and the display will show the timer counting down.
8. The oven will stop heating and beep several times when finished.

## Cookies Function (“COOKIES”)

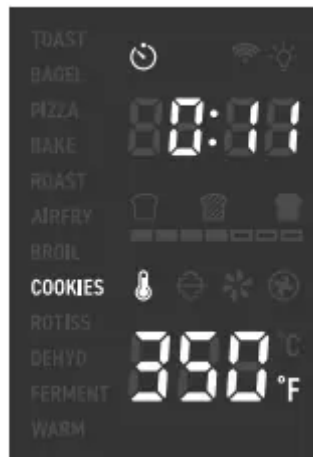

This function is ideal for baking homemade or commercially prepared cookies and other baked treats. Also ideal for ready-to-bake crescent rolls, cinnamon rolls, biscuits, and strudels.

Heating Elements: Top and bottom heating elements cycle on and off.

Rack Position: Mid

1. If using the wire rack, insert at mid position and close the oven door.
2. Turn the FUNCTION knob to “COOKIES”, which will blink on the display.
3. Optionally, customize the temperature and time. You can do this anytime during cooking (except during preheating).
  - Turn the TIME/TEMP knob to adjust the time between 1 min–6 hr.
  - Press the TIME/TEMP knob once to control temperature. Turn the knob to adjust the temperature between 150°–450°F / 65°–232°C.
4. Press START/CANCEL to begin. Preheating will start automatically. The START/CANCEL button will light up, and the display will show “PrE”.

5. When preheating completes, the oven will beep several times, the display will flash, and the START/CANCEL button will blink continuously.
6. Place food inside the oven. If using the food tray, insert at mid position. Close the oven door.
  - Optionally, lightly grease the enamel food tray or line with baking paper to prevent food from sticking.
    - Never put baking or parchment paper into the oven without food on top. Air circulation can cause paper to move and touch heating elements.
7. Press START/CANCEL to begin cooking. The button will light up, and the display will show the timer counting down.
8. The oven will stop heating and beep several times when finished.

### Rotisserie Function (“ROTISS”)



This function is used for rotating roasts. Ideal for roasting a whole chicken.

Heating Elements: Top and bottom heating elements cycle on and off.

Rack Position: Rotisserie slots

1. Turn the FUNCTION knob to “ROTISS”, which will blink on the display.
2. Optionally, customize the temperature and time. You can do this anytime during cooking.
  - Turn the TIME/TEMP knob to adjust the time between 1 min–6 hr.
  - Press the TIME/TEMP knob once to control temperature. Turn the knob to adjust the temperature between 150°–400°F / 65°–205°C.
3. Insert the food tray at low position to collect drippings.

4. Place the whole chicken (or other food item) on the rotisserie shaft. Place the rotisserie forks on either side of the shaft and insert them into the chicken to secure it on the shaft. Tighten the knobs on the forks to secure them. [Figure 2.3-2.5]
5. Use the rotisserie handle to place the chicken inside the oven, securing both ends of the rotisserie shaft into the rotisserie slots. Close the oven door.
6. Press START/CANCEL to begin cooking. The button will light up, and the display will show the timer counting down.
7. The oven will stop heating and beep several times when finished. Use the rotisserie handle to take out the chicken.

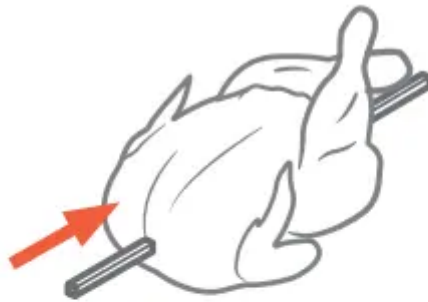

Figure 2.3



Figure 2.4

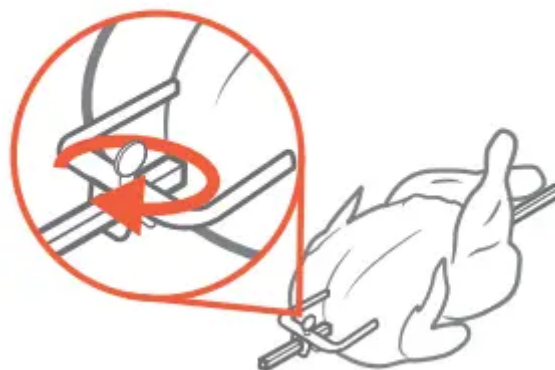

Figure 2.5

## Dehydrate Function (“DEHYD”)



This function combines low and stable heat with automatic airflow to evenly dry out foods without cooking. Ideal for drying fruit or vegetable chips.

Heating Elements: Bottom heating elements cycle on and off.

Rack Position: Mid for 1 tray

1. Place food on the wire rack or fry basket.
  - When dehydrating foods that may drip, such as marinated jerky, place the food tray in the low rack position to collect drippings.
  - Optionally, to prevent staining when dehydrating certain foods (such as beets or marinated meats with dark sauces), line the rack or basket with baking paper.
    - Never put baking or parchment paper into the oven without food on top. Air circulation can cause paper to move and touch heating elements.
2. Insert wire rack or fry basket at mid position. If using multiple trays, insert at low or high positions. Close the oven door.
3. Turn the FUNCTION knob to “DEHYD”, which will blink on the display.
4. Optionally, customize the temperature and time. You can do this anytime during cooking.
  - Turn the TIME/TEMP knob to adjust the time between 30 min–24 hr.
  - Press the TIME/TEMP knob once to control temperature. Turn the knob to adjust the temperature between 100°–180°F / 38°–80°C.
5. Press START/CANCEL to begin dehydrating. The button will light up, and the display will show the timer counting down.
6. The oven will stop heating and beep several times when finished.

## Ferment Function (“FERMENT”)



This function is designed to precisely hold low temperatures, providing an ideal environment for proofing bread, rolls, pizza, and dough.

Can also be used for making yogurt with an appropriate recipe (using 110°F / 43°C temperature and 12 hr time).

Heating Elements: Bottom heating elements cycle on and off.

Rack Position: Low

1. Place dough in a heat-safe container. Cover and place on the food tray or wire rack. Insert at low position and close the oven door.
2. Turn the FUNCTION knob to “FERMENT”, which will blink on the display.
3. Optionally, customize the temperature and time. You can do this anytime during cooking.
  - Turn the TIME/TEMP knob to adjust the time between 30 min–12 hr.
  - Press the TIME/TEMP knob once to control temperature. Turn the knob to adjust the temperature between 80°–110°F / 27°–43°C.
4. Press START/CANCEL to begin fermentation. The button will light up, and the display will show the timer counting down.
5. The oven will stop heating and beep several times when finished.

## Warm Function (“WARM”)



1. This function is designed to keep food warm at the recommended temperature to prevent bacterial growth (160°F / 70°C or above). Heating Elements: Bottom heating elements cycle on and off. Rack Position: Low 1. Place hot food in a heat-safe container. Cover and place on the food tray or wire rack. Insert at low position and close the oven door.
2. Turn the FUNCTION knob to “WARM”, which will blink on the display. 3
3. Optionally, customize the temperature and time. You can do this anytime during cooking.
  - Turn the TIME/TEMP knob to adjust the time between 1 min–12 hr.
  - Press the TIME/TEMP knob once to control temperature. Turn the knob to adjust the temperature between 140°–230°F / 60°–100°C.
4. Press START/CANCEL to begin warming. The button will light up, and the display will show the timer counting down.
5. The oven will stop heating and beep several times when finished.

## USING THE APP

- The VeSync app allows you to access additional smart air fryer toaster oven functions, including those listed below.
- Note: Due to ongoing updates and improvements, the VeSync app may be slightly different than shown in the manual. In case of any differences, follow the in-app instructions.

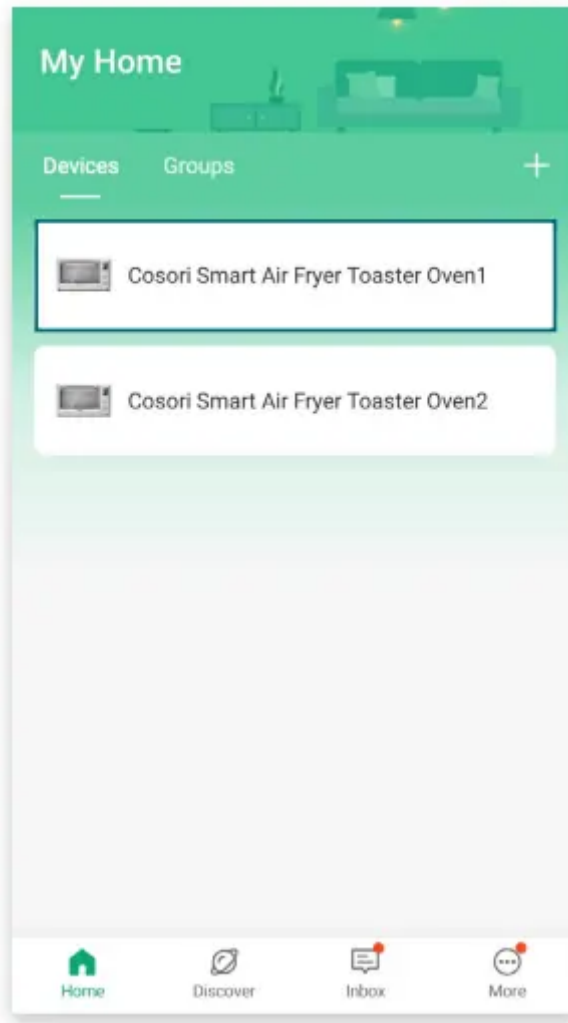

- From the My Home screen, tap the smart air fryer toaster oven name to view device options and details.

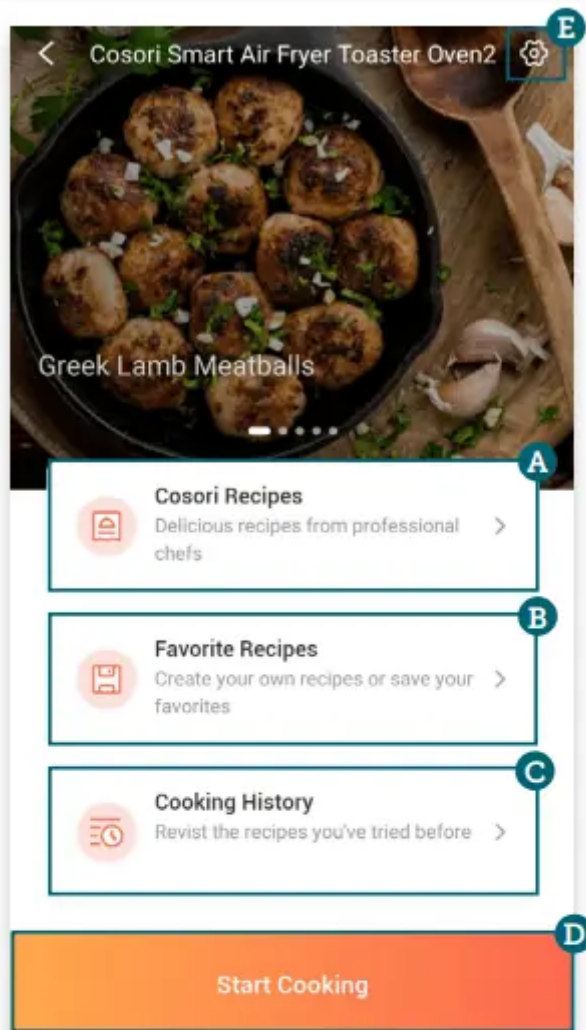



- A. Tap **Cosori Recipes** to view and choose a recipe from the Cosori chefs (see page 26).
- B. Tap **Favorite Recipes** to create or view a custom recipe (see page 29).
- C. Tap **Cooking History** to view recently used recipes.
- D. Tap **Start Cooking** to cook with custom settings (see page 28).
- E. Tap  to view Device Settings (see page 30).

• Note: App functionality is only available when the smart air fryer toaster oven is connected to the VeSync app

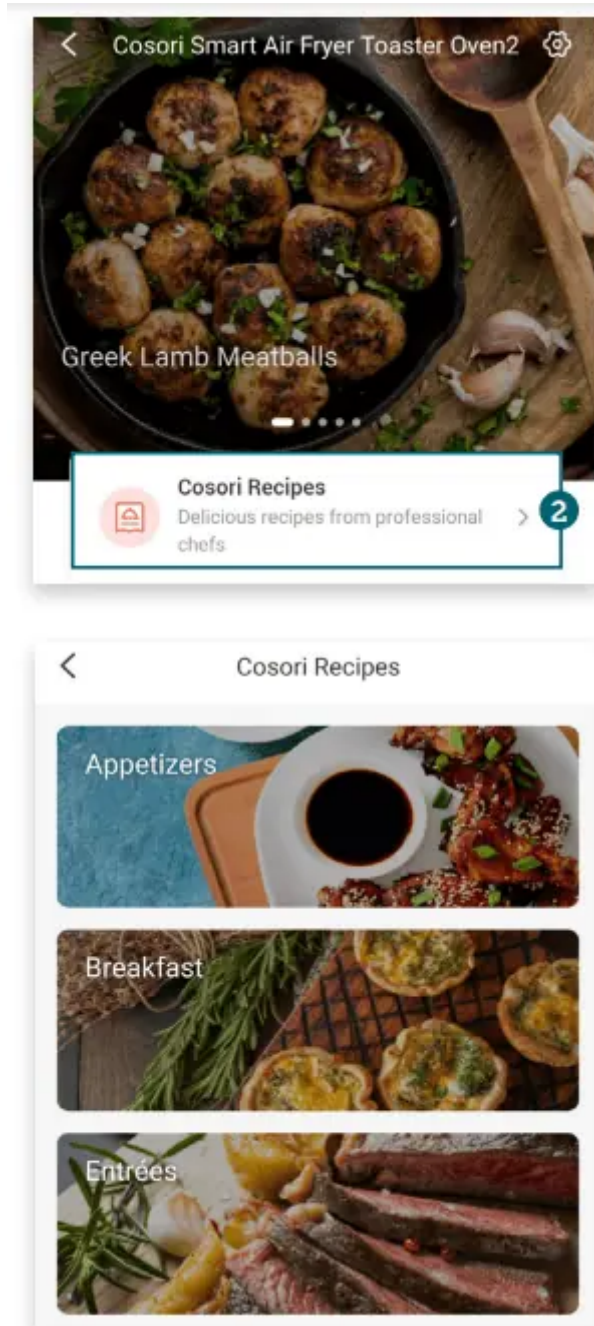
## Cooking with Cosori Recipes



1. From the My Home screen, tap the name of the oven.
2. Tap Cosori Recipes, select a category, and select a recipe to cook.
  - You can tap  to search for a recipe.



**Almond-Crusted Salmon**  
Broil(450°F for 10 minutes)  
Yields 4 Servings  
Prep Time:20 minutes

**Ingredients**

ingredient

- 4 salmon fillets (8 ounces each)
- 4 tablespoons honey
- 1 cup almonds
- ¼ cup sesame seeds
- 2 ounces Parmesan cheese

**Cook This Dish**

**3**

3. Follow the recipe instructions to prepare food. Then, tap Cook This Dish.

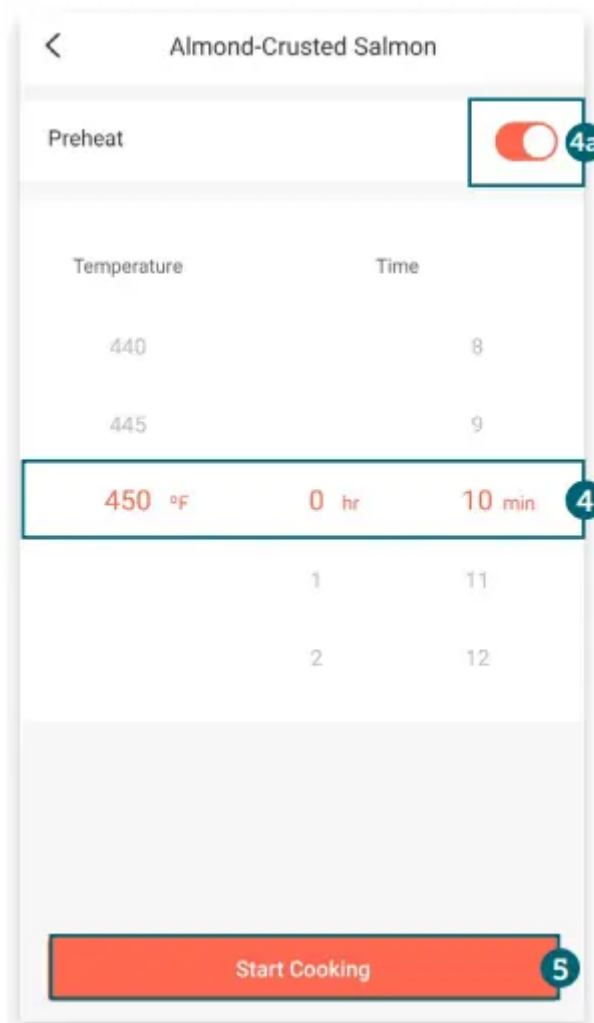

4. Optionally, customize the cooking time and temperature.

- Most recipes automatically include preheating. You can tap  to skip preheating. This is not recommended unless the oven is already heated up to the right temperature.
- You can also tap Delay Start to delay the start of the cooking time. Cooking with Cosori Recipes (cont.)





5. When ready, tap Start Cooking and press the START/CANCEL button on the oven to begin cooking.

- You can tap Stop to stop cooking at any time.

6. Wait for the cooking timer to finish.

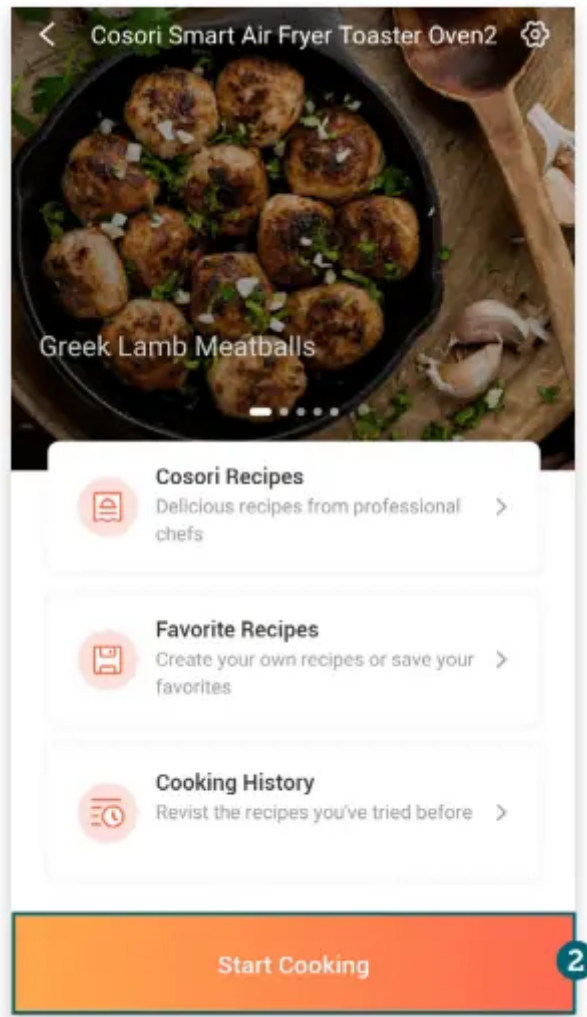
## Custom Cooking



1. From the My Home screen, tap the name of the air fryer to open the air fryer screen.
2. Tap Start Cooking.
3. Select a cooking program.
4. Customize the cooking time and temperature.
  - Remember to tap  to use Preheat unless the air fryer is already preheated.

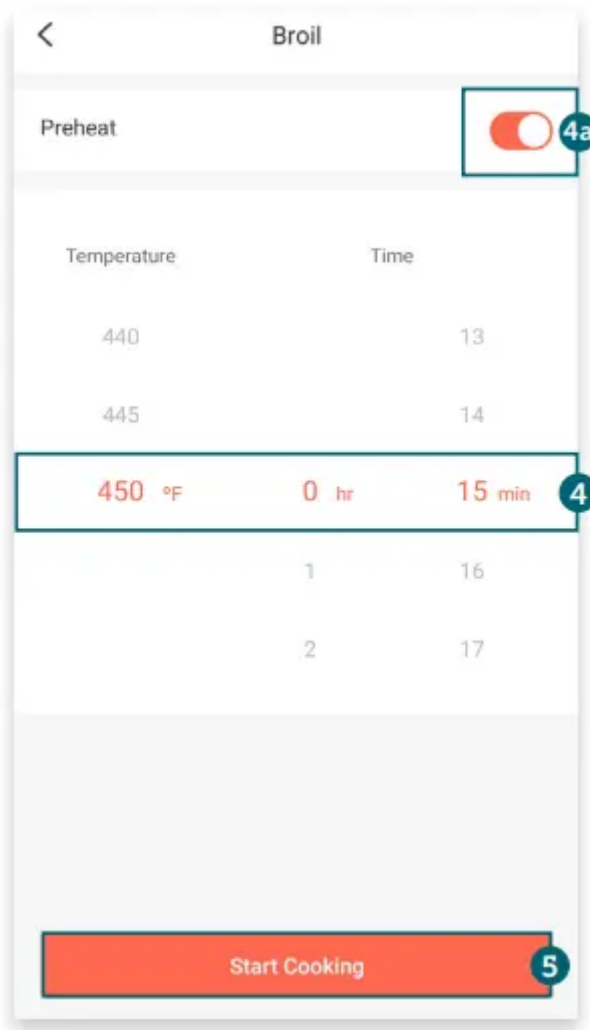

5. When ready, tap Start Cooking and press the START/CANCEL button on the oven to begin cooking



## Creating a Custom Recipe

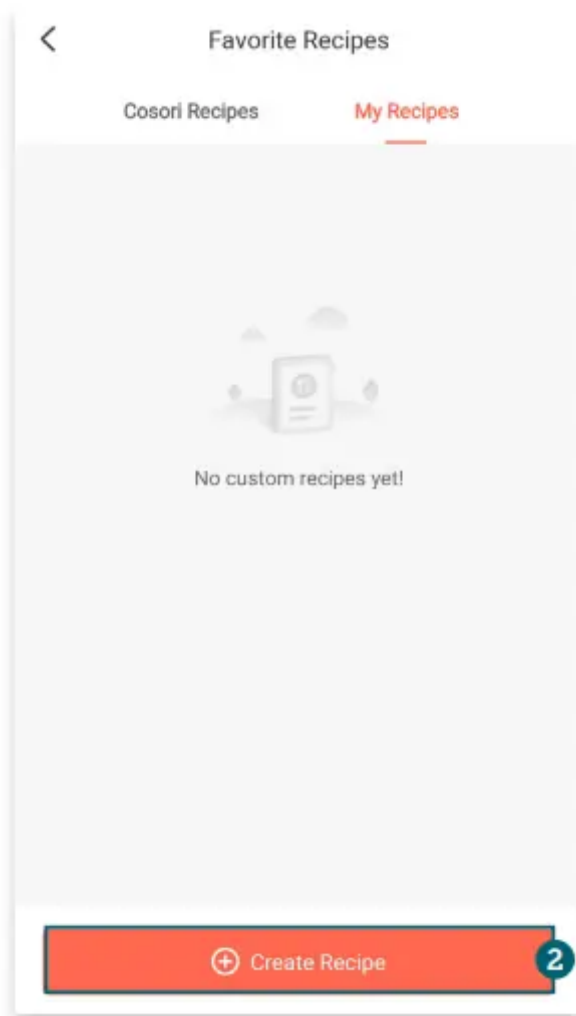

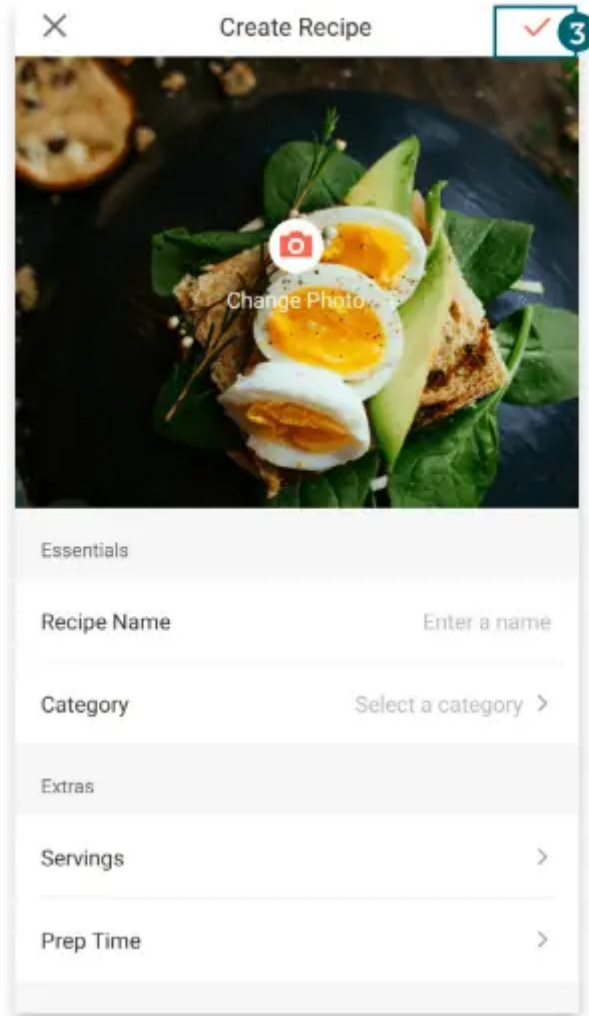

1. From the My Home screen, tap the name of the oven.
2. Tap Favorite Recipes, then tap Add Recipe.

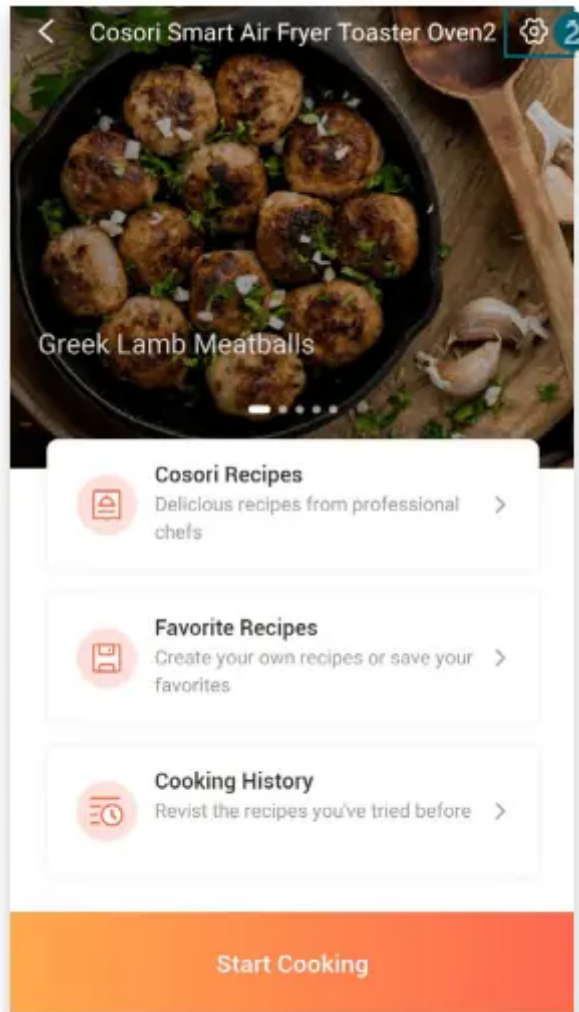

3. Enter the details of the recipe. When you're finished, tap . Once you have successfully created a custom recipe, you can use it to cook

## Device Settings



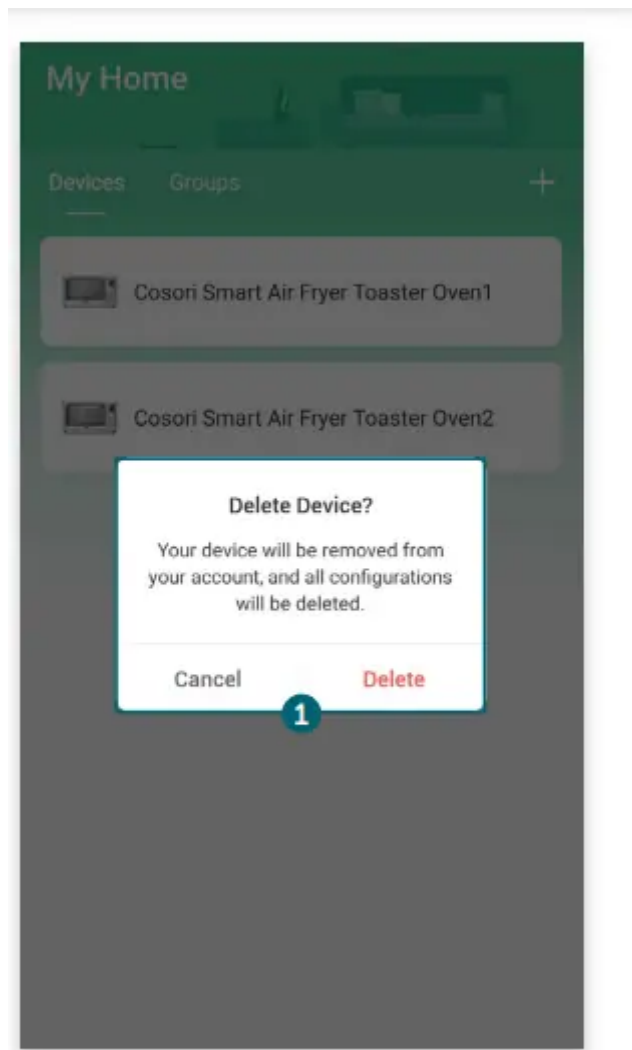

1. From the My Home screen, tap the name of the oven.
2. Tap  to see Device Settings. To change any setting, tap any of the text, icons, or  symbols on the right side of the screen. For example, tap the oven name to change the name.



Resetting your oven can help you troubleshoot any issues you may have, including if your oven has gone offline. **Resetting Your Toaster Oven**

Note: Resetting the oven will erase all of your custom settings and restore the default settings.

1. Delete your oven from the VeSync app. Swipe left (iOS) or tap and hold (Android), and tap Delete.
2. Press and hold  for more than 15 seconds until  blinks rapidly on the display. Your oven will automatically be in Configuration Mode and ready for setup.

## CARE & MAINTENANCE

Clean oven accessories (including trays, etc.) and oven interior after every use.

Note:

- The walls on the inside of the oven have a nonstick coating for easy cleaning.
- Do not use abrasive cleaners, metal scouring pads, or metal utensils on any part of the oven, including trays and other accessories. These will scratch or damage their surfaces.

- This oven contains no user-serviceable parts. Any repairs should be performed by an authorized service representative.
1. Before cleaning, turn off and unplug the oven, and allow it to cool completely. Open the door for faster cooling.
  2. Apply non-abrasive liquid cleanser or a mild spray solution to a soft, damp cloth or sponge (not the oven surface) and wipe all parts of the oven. Do not use a dry cloth on the display screen, or it may be scratched.
  3. To clean the glass door, use a glass cleaner or mild detergent and a soft, damp sponge or soft, plastic scouring pad.
  4. Let all surfaces dry completely before plugging in or turning on the oven

## **Cleaning the Accessories**

Note: After each use, slide out the crumb tray and discard crumbs.

1. Apply non-abrasive liquid cleanser or a mild spray solution to a soft, damp sponge or soft, plastic scouring pad (not the accessory surface). Wipe accessories and soak in warm, soapy water if necessary.
2. For stubborn grease:
  - In a small bowl, mix 2 US tbsp / 30 mL of baking soda with 1 US tbsp / 15 mL of water to form a spreadable paste.
  - Use a sponge to spread the paste on the trays and scrub. Let the trays sit for 15 minutes before rinsing.
  - Wash trays with soap and water.
3. Dry thoroughly.
4. Replace the crumb tray into the oven before plugging in or turning on the oven.

## **Storage**

1. 1. Clean and dry the oven and all accessories.
2. Insert the crumb tray into the oven. Insert the rack at mid position. Make sure the oven door is closed.
3. Store the oven in an upright position. Do not store anything on top.

# TROUBLESHOOTING



Problem	Possible Solution
The oven will not turn on	Make sure the oven is plugged in.
Food is not completely cooked.	Increase cooking temperature or time.
Food is overcooked or burned.	<p>Decrease cooking temperature or time.</p> <p>Make sure food items are not too large and are not touching the heating elements.</p>
Food is cooked unevenly	<p>Preheat the oven manually by using the Toast function set to Level 4.</p> <p>Make sure food items are not too closely packed into a tray, rack, or other container.</p>
White smoke or steam is coming out of the oven.	<p>The oven may produce some white smoke or steam during cooking. This is normal.</p> <p>During first use, dust from the packing process may cause white smoke. This is normal for toaster ovens and many other kitchen appliances. To eliminate any dust, see Test Run</p> <p>Excess oil or fatty foods may produce white smoke. Make sure the inside of the oven is cleaned properly and not greasy.</p>
Dark smoke is coming out of the oven.	<p>Immediately press START/CANCEL and unplug your oven. Food is burning. Wait for smoke to clear before opening the oven door</p>
A thermometer shows that the oven temperature is different from the oven setting.	<p>Commonly used thermometers usually have low sensitivity and take over 10 minutes to measure the correct temperature. This will not affect cooking</p>
Display shows Error Code “ <b>E1</b> ”	<p>There is an open circuit in the temperature monitor. Contact Customer Support</p>
Display shows Error Code “ <b>E2</b> ”	<p>There is an open circuit in the temperature monitor. Contact Customer Support</p>
Display shows Error Code “ <b>E7</b> ”	<p>The oven has been plugged into an incorrect power source, such as a 220–240V outlet. Unplug the oven. Only use the</p>



oven with 120V, 60Hz outlets, such as those in the US and Canada.

## VESYNC APP TROUBLESHOOTING

### 1. My oven isn't connecting to the VeSync app.

- During the setup process, you must be on a secure 2.4GHz WiFi network. Confirm that the network is working correctly.
- Make sure the WiFi password you entered is correct.
  - There should be no spaces at the beginning or end of the password.
  - Test the password by connecting a different electronic device to the router.
  - If you're manually typing in the SSID and password, double check that both are entered correctly.
- Your oven should be within 164 ft / 50 m visible range of the router. Your phone should be as close as possible to your oven.
- Your router may need to be at a higher location, away from obstructions.
- Make sure your oven and router are away from appliances (such as microwave ovens, refrigerators, electronic devices, etc.) to avoid signal interference.
- If you're using a VPN, make sure it's turned off while setting up your oven.
- Reset the oven

### Connecting for Advanced Users

- Try these suggestions for checking your router configuration.
- Make sure you don't have too many devices connected to your router on the 2.4GHz band. Your router may limit the number of devices you can connect. Turn off this limit in your router settings.
- Disable portal authentication. If portal authentication is enabled, the oven will not be able to access your WiFi network, and setup will fail.

Note: Portal authentication requires you to sign in to your WiFi network through a web page before you can use the internet.

- Make sure that the router DHCP service is enabled. This service is used to assign an IP address to your oven. If the DHCP service is disabled, the oven will not be able to obtain an IP address and will not be able to connect to your WiFi network.
- Disable URL filtering.
- Open firewall ports. Your oven needs to use ports 443, 4005, 1883, and 17273 to connect to your WiFi network.

- Disable wireless MAC address filtering.
- Confirm that your ISP has not disabled ports 1883 or 17273.

## 2. Why do I need to turn on my phone's location or GPS when I'm setting up my oven?

- During configuration, the VeSync app will need to access your WiFi information. Many newer phones require permission to access GPS or location services in order to access WiFi information or search for nearby WiFi networks. This is necessary for connecting a smart product to WiFi.

## 3. My oven is offline.

1. Make sure the oven is plugged in and has power, then refresh the VeSync menu by swiping down on the screen.
2. Make sure your router is connected to the internet, and your phone's network connection is working properly.
3. Delete the offline oven from the VeSync app. Swipe left (iOS) or tap and hold (Android), and tap Delete.
4. Reset the oven
5. Once the oven has been deleted and reset, reconfigure the oven with the VeSync app

Note: Power outages, internet outages, or changing WiFi routers may cause the oven to go offline.

## 4. Amazon Alexa can't find my app or can't discover my oven.

- Make sure your wireless network router is close enough to the oven. The oven must be within 164 ft / 50 m visible range from the router.
- Make sure the oven is plugged in and has power.
- Check that your Amazon Alexa is working properly.
- Make sure your Amazon Alexa is connected to the same network as the oven.

### **Warning**

This content is compiled from multiple sources and is provided for reference purposes only. It may not be complete or fully applicable to all situations. If you are unable to resolve your issue, please contact the product manufacturer or an authorized service provider for official support.