

User Manual Channel Home Theater Surround Sound Bar



PACKAGE CONTENTS



VIZIO
Sound Bar



Wireless Subwoofer



2 x Satellite
Speakers



Remote Control
with 2x AAA Batteries



Stereo RCA to
3.5mm Audio Cable



3.5mm to 3.5mm
Audio Cable



Coaxial Audio
Cable



HDMI Cable

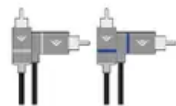

2 x Satellite Speaker
Audio Cables



Digital Optical
Cable



2 x Power Cables



4 x Wall
Mount Screws



2 x Wall
Mount Brackets
(Satellite Speakers)



2 x Wall
Mount Brackets
(Sound Bar)



Wall Mount Template



Quick Start Guide



4 x Cable Ties

CONTROLS & CONNECTIONS

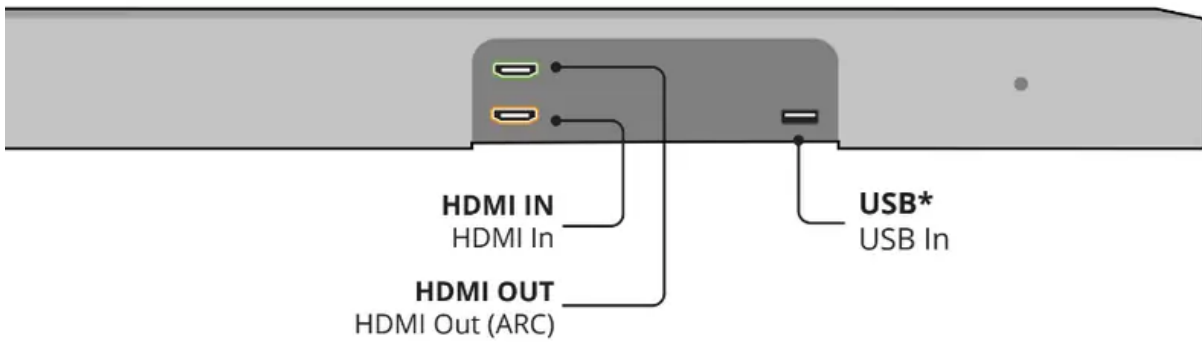
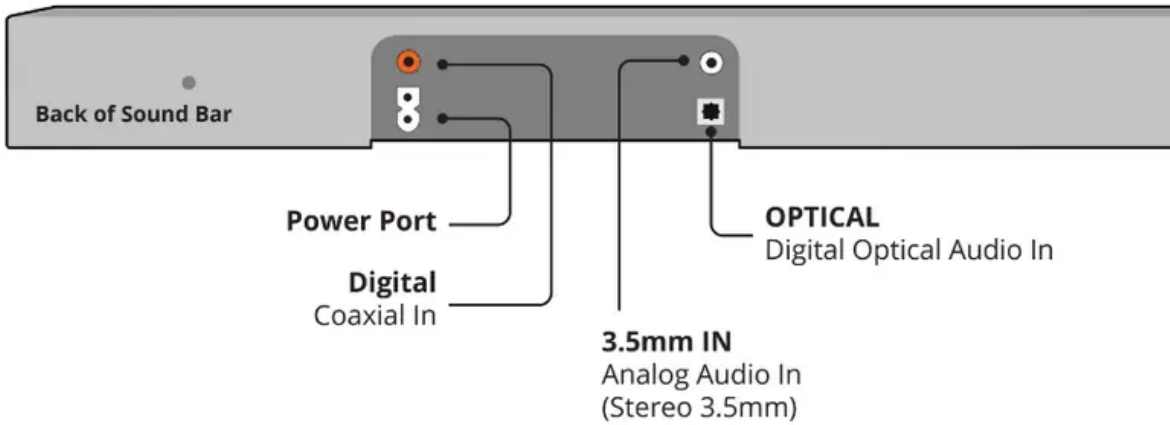

* Supports .WAV and .MP3 file format playback only.

Top of Sound Bar

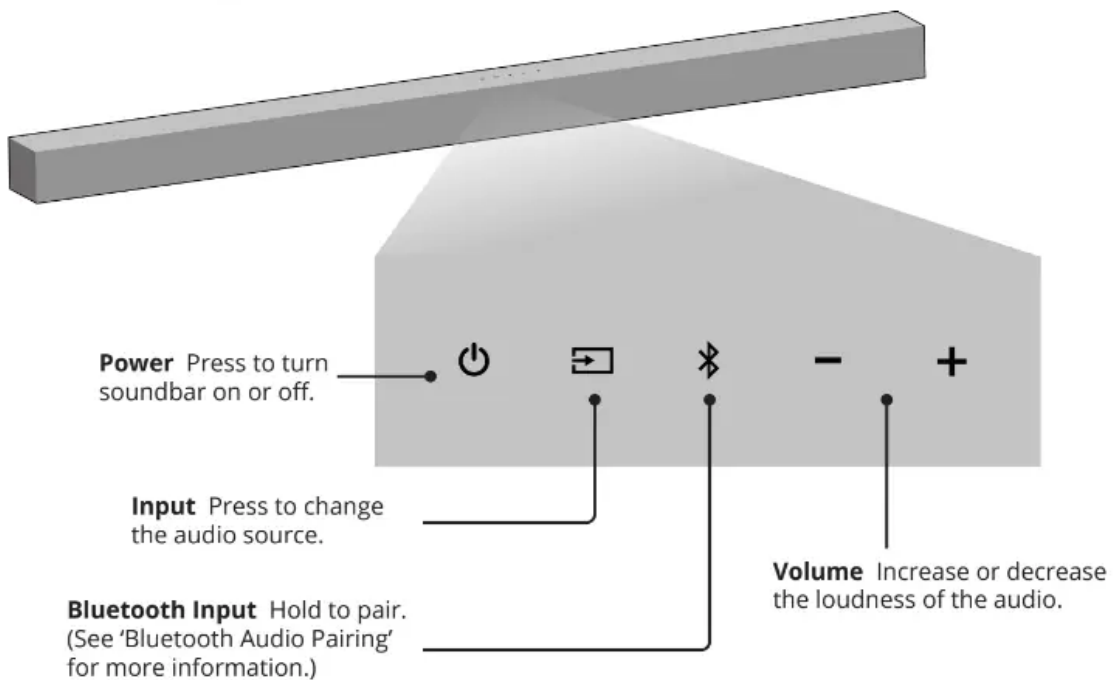

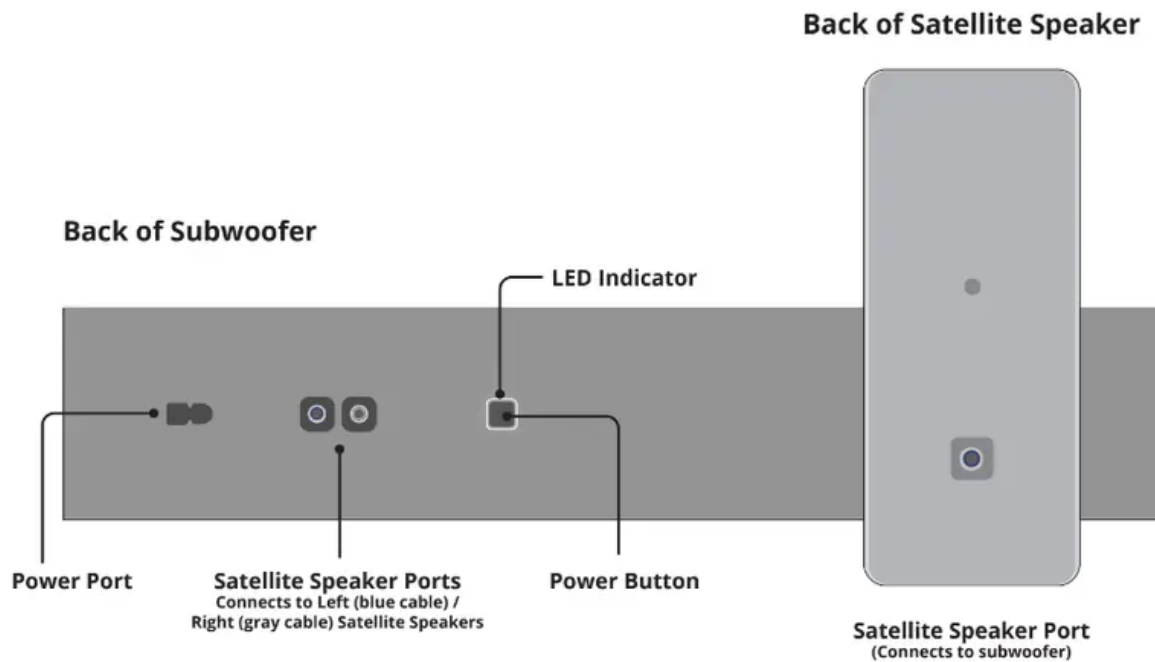

FIRST-TIME SETUP

1. Choose one cable* and connect it to your TV

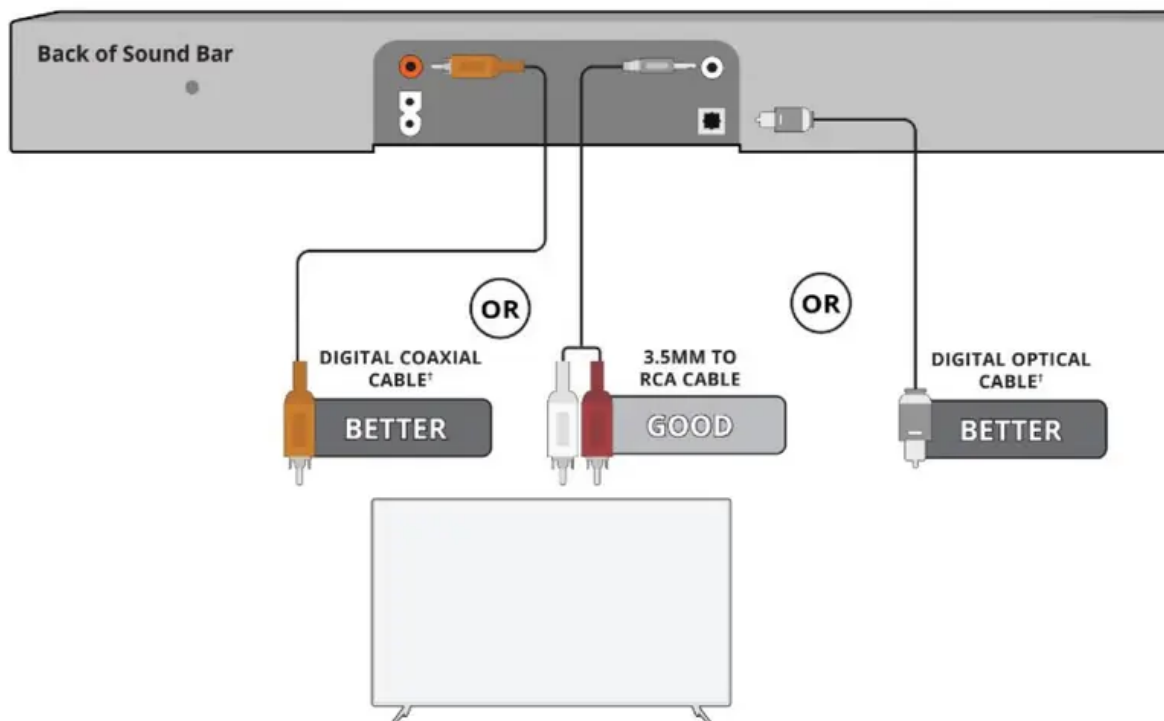

* Not all TVs/Displays have the audio outputs shown above. To connect the Sound Bar directly to your other devices (Blu-Ray player, game system, etc.) see your device's user manual.

† When using either of the Digital Inputs, if there is no audio: (A) try setting the TV/Display output to PCM or (B) Connect directly to your Blu-ray/other a source, some TV/Display do not pass through digital audio.

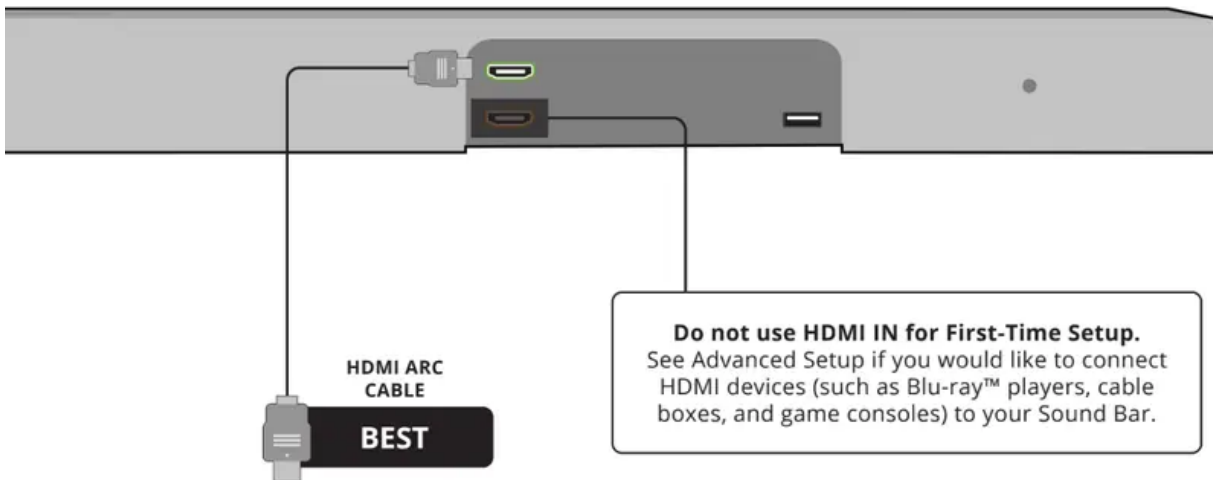

- HDMI cables send Video (Out) and receive Audio from the TV/Display.
- See the Connecting with HDMI section for more information
- Connect the Sound Bar to your TV/Display* using one of the connection types to the left. Choose the best possible connection type. Be sure the TV/Display port is an audio output, not an audio input.

* Not all TVs/Displays have the audio outputs shown above. To connect the Sound Bar directly to your other devices (Blu-ray player, game system, etc) see your device's user manual.

2. Connect the power cable to the sound bar AC IN as shown.

Plug the power cable into an electrical outlet.

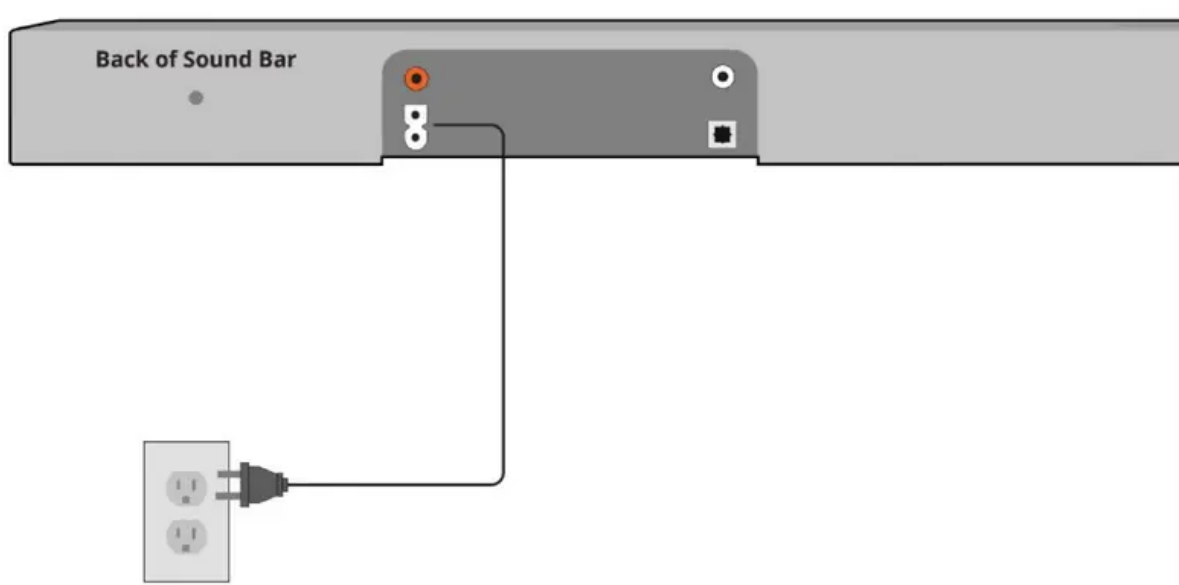

3. Connect the satellite speakers to the subwoofer using the included satellite speaker

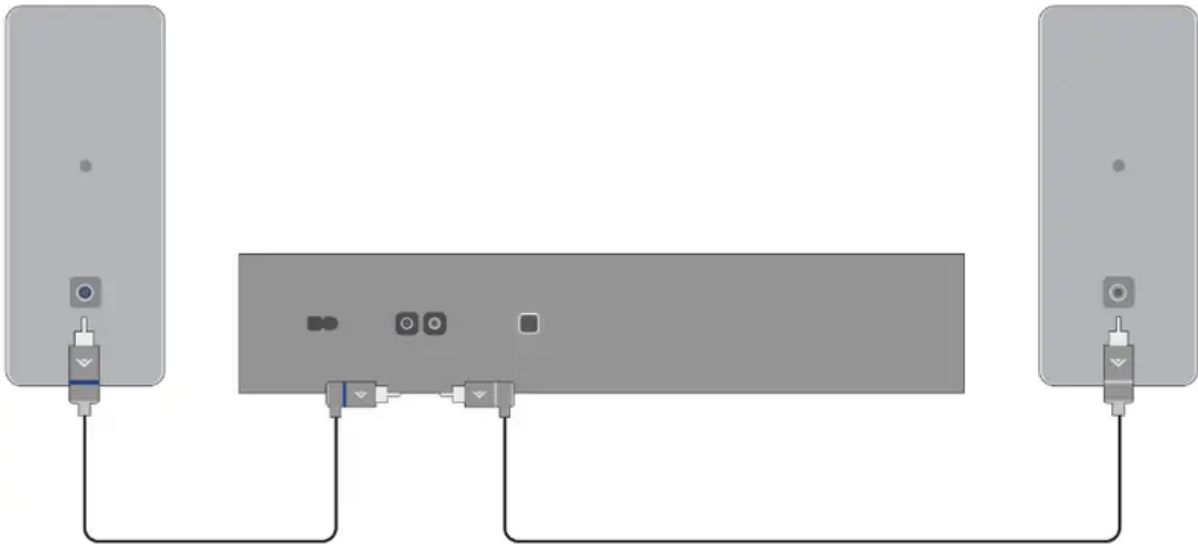

- Match the color coded speaker cable to the matching speaker port color.
- Blue for left surround and grey is for right surround.

Back of Subwoofer



4. Connect a power cable to the subwoofer

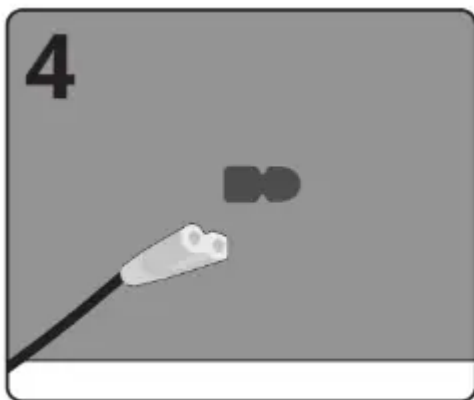

5. Plug the power cable into a power outlet

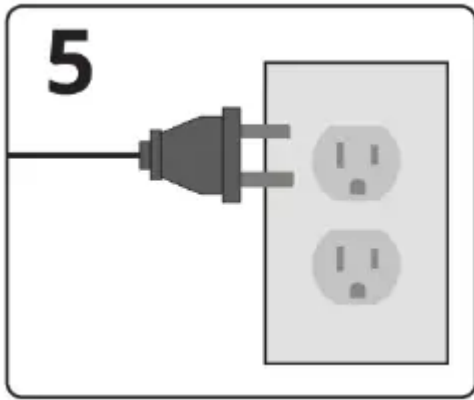

6. The subwoofer should automatically power on and link to the sound bar when plugged in. The LED will glow to signal to confirm.

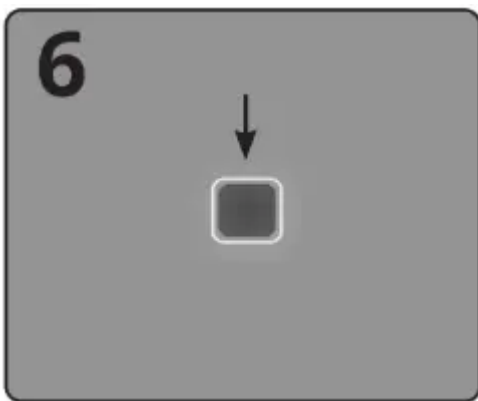

7. Remove the battery cover by gently sliding it away from the remote.



8. Insert the included batteries and gently slide the battery cover back into place.



When needed, VIZIO recommends replacing the batteries that came with this remote with two, new Duracell 'AAA' alkaline batteries.

9. Turn on your TV and sound bar. The sound bar will automatically begin searching for an active input.*

- The LED indicators on the front of the sound bar will begin cycling in pairs through inputs until an audio source is detected.**

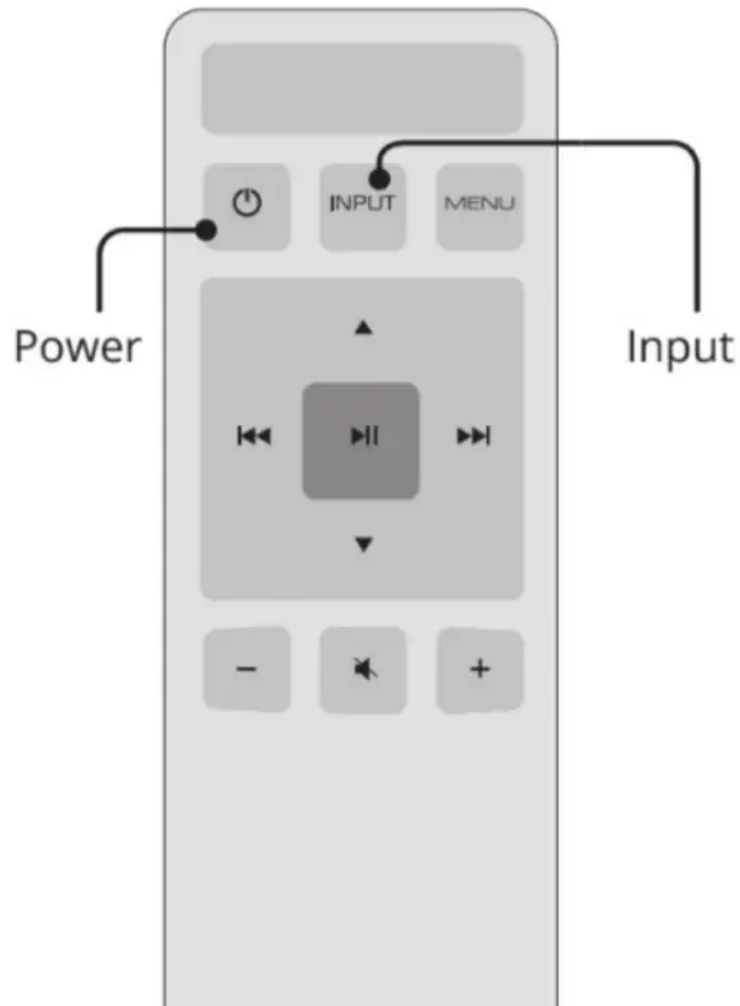

Tip: Pressing the INPUT button will stop the auto detect function.

- You can press the INPUT button to switch between audio sources. For example, if you connected your TV to AUX, set the sound bar to AUX.

*Occurs only during first-time set up.

**Auto detect function only occurs once when the sound bar is first powered on. To enable this feature again, you must do a Factory Reset (see the Using Button Combinations section for more information) or press and hold the INPUT button for 3 seconds.

USING THE REMOTE

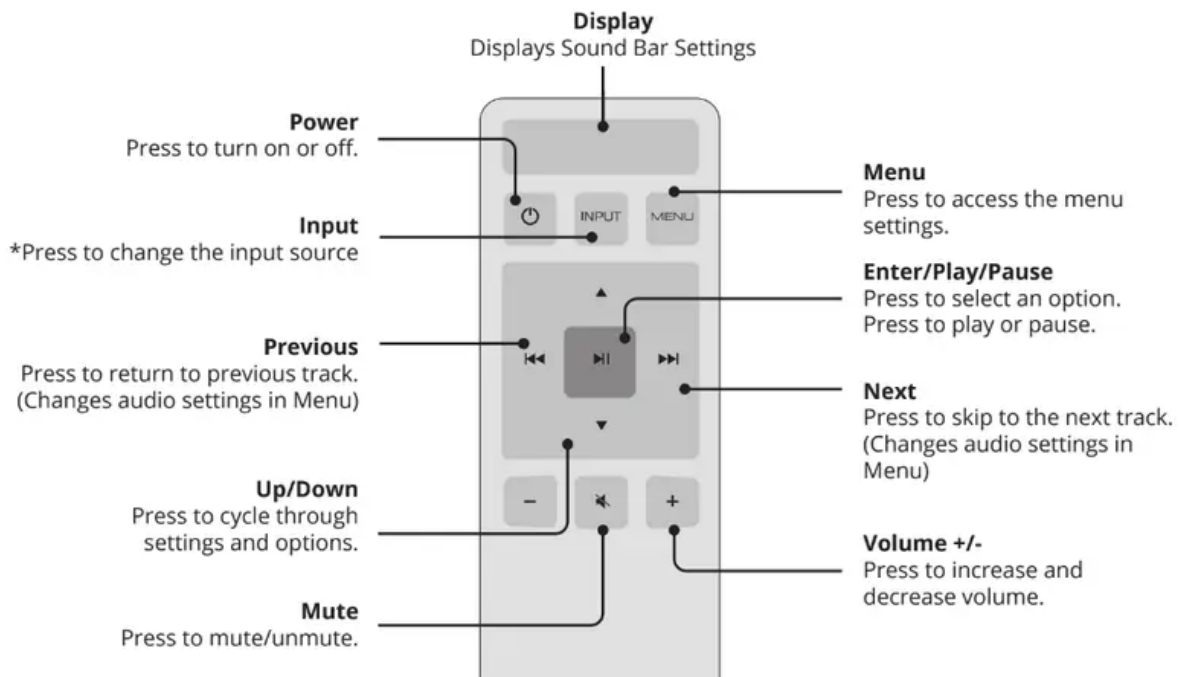

PROPER PLACEMENT

For the best surround sound experience, position the sound bar and subwoofer as shown. The sound bar should be close to ear level.

OPTION 1

You can stand the subwoofer upright with the ports facing out.

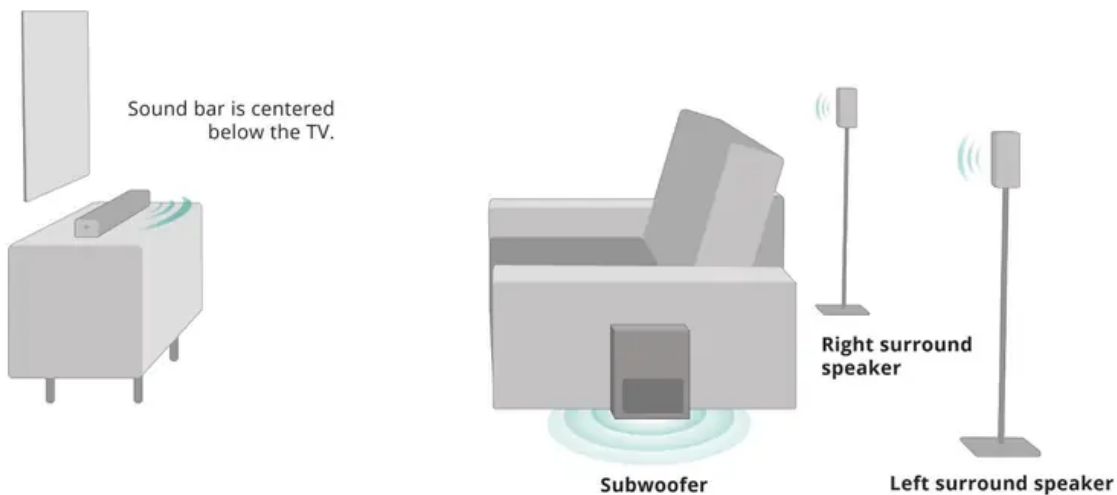

Note: Do not block the subwoofer port.

Note: Speaker stands not included.

OPTION 2

If your couch permits, you can place the subwoofer underneath it. Make sure there is sufficient

room to freely place the subwoofer underneath your couch. Do not place the couch directly on top of the subwoofer if there isn't enough room.

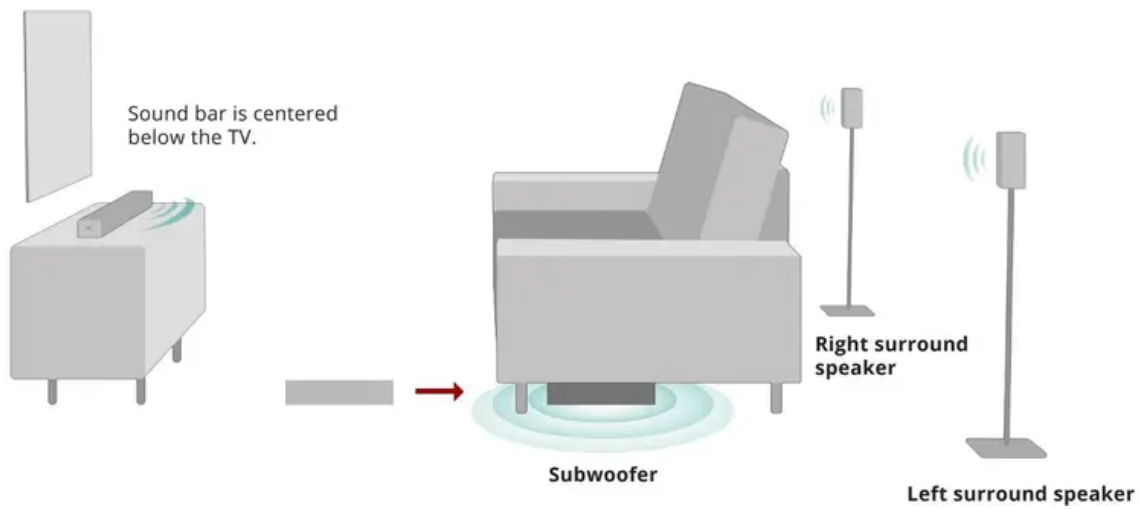

Note: Do not block the subwoofer port. Port should be facing the front of the couch.

Note: Speaker stands not included.



LED INDICATORS

Press the Menu button and use the Up/Down Arrow buttons on the remote to access the different functions and acoustic settings of the sound bar. Each function and setting will be displayed on the remote control's LCD display. The LED Indicators will behave differently with each function.

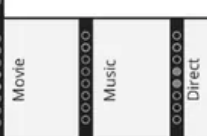
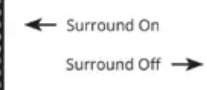

LED Indicators are located here.

Function	LED Behavior	Description
Bluetooth Pairing BT Pair	(When searching for device) Flash from Bottom to Top and back continuously.	Press the Enter button on the remote. The sound bar will be discoverable for 15 minutes. You can now search for the sound bar (VIZIO SB3651n) using your Bluetooth Device. The sound bar will power down if no device is found. Note: Set your Bluetooth device into pairing mode prior to the sound bar.
Bass Levels Bass	Two center LEDs indicate Bass level 0.	Press the Next/Previous button to increase/decrease the bass level. The LED indicators will move to the top with increasing levels and to the bottom with decreasing levels. Note: Decreasing the level to the minimum mutes the subwoofer.
Treble Levels Treble	Two center LEDs indicate Treble level 0.	Press the Next/Previous button to increase/decrease the treble level. The LED indicators will move to the top with increasing levels and to the bottom with decreasing levels.
Center Levels Center	Two center LEDs indicate Dialogue is centered.	Press the Next/Previous button to increase/decrease the presence of dialog in the center channel. The LED indicators will move to the top when the dialog presence is increased and to the bottom when the dialog presence is decreased.
Surround Levels Surround	Two center LEDs indicate Surround is centered.	Press the Next/Previous button to increase/decrease the surround sound level. The LED indicators will move to the top with increasing levels and to the bottom with decreasing levels. Note: Surround must be On to adjust the surround level.

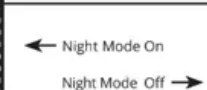
Function	LED Behavior	Description
Surround Balance Surr Bal	Two center LEDs indicate Surround Balance is centered.	Press the Next/Previous button to increase/decrease the surround balance level on each side. The LED indicators will move to the top with balance levels to the right and down with balance levels to the left.
Subwoofer Levels Subwoofer	Two center LEDs indicate subwoofer level 0.	Press the Next/Previous button to increase/decrease the level of the subwoofer. The LED indicators will move to the top with increasing levels and to the bottom with decreasing levels. Note: Decreasing the level to the minimum turns off the subwoofer.
Equalizer Mode EQ		Press the Next/Previous button to toggle between 3 preset equalizer settings, Music, Direct and Movie. Note: Movie mode is on by default.
Surround On/Off Surnd		Press the Next/Previous button to enable/disable surround sound. When enabled (On), Direct and Movie mode will produce 5.1 surround sound. Music will produce 3.1 surround sound. When disabled (Off), the satellite speakers will be disabled. Note: If EQ mode is set to Direct and Surround is set to Off, the sound bar will output 2.1 audio without center or satellites.
DTS TruVolume On/Off TruVol		Press the Next/Previous button to enable/disable TruVolume. When enabled (On), TruVolume provides a consistent and comfortable volume level for a more enjoyable listening experience. Note: Default is setting is Off
Night Mode On/Off Night		Press the Next/Previous button to enable/disable Night Mode. When enabled (On), the sound bar will lower bass frequency levels to provide a more quiet environment (ideal for apartment living and homes with sleeping children).

Function	LED Behavior	Description
Virtual:X VRT:X	← Virtual:X On Virtual:X Off →	Press the Next/Previous button to enable/disable Virtual:X . When enabled (On), all inputs will produce a virtual sound technology that simulates the effect of having overhead sound. When disabled (Off), all sources will playback in without virtualization.
TV Remote VZtv Rmt On	← TV Remote On TV Remote Off →	Press the Next/Previous button to enable/disable VIZIO TV Remotes. When enabled (On), you can use a VIZIO TV remote control to turn on the sound bar (using the TV Volume Up button) and control volume.
Program Remote Prg Remote	--	Press the Next/Previous and Play buttons to toggle and select and program your TV remote to control the Volume Down , Volume Up , and Mute functions on your sound bar. See the <i>Program Remote</i> section for more information.
Eco Power / Energy Star Mode Eco Pwr	← Eco Power On Eco Power Off →	Press the Next/Previous button to enable/disable Eco Power Mode. When enabled (On), the sound bar will go into standby after a period of inactivity. The sound bar will automatically turn off when no audio signal is detected. Off disables this feature. Note: If you would like to cast content without the need to manually turn on the sound bar, set this function to OFF.
Speaker Test Spkr Test	—	Press the Play/Pause button to activate the speaker test function. A voice will begin calling out each speaker beginning with <i>left front</i> (Left Front, Center, Right Front, Right Rear, Left Rear, and subwoofer-white noise). If any of these are missing, check the connection and run the speaker test function again.
Info Info	—	Press the Play button to have the sound bar verbally announce the current sound bar input and audio type being played with corresponding LED indicators.

Function	LED Behavior	Description
AV Delay AV Delay	LED at the bottom indicates no delay	Press the Next/Previous button to increase/decrease the amount of audio delay. The LED indicators will move to the top with increasing audio delay levels.
Reset Reset All	All 8 LEDs will flash 3 times	Press the Next/Previous buttons to reset either Audio or All settings. Press the Play button to select. Audio - Only audio settings, such as bass and treble levels, will be reset. All - All paired Bluetooth devices will be unpaired and all settings will be lost. All programmed IR remotes will also be removed. See the <i>Reset to Factory Default Settings</i> section for more information.
When a Dolby Digital Plus or DTS signal is detected.	Dolby Digital Plus and DTS Indicator LED	Dolby Digital and DTS are available on the Coaxial In , HDMI ARC , HDMI In , and Digital Optical Audio In inputs. Dolby Digital Plus is only available on HDMI In input. When a Dolby Digital or DTS signal is detected, the Dolby Digital Plus (White) / DTS (Amber) indicator LED will light up for 5 seconds before fading away.

USING BUTTON COMBINATIONS

There are 3 functions that are triggered by 3 different button combinations on the sound bar.



Buttons are located here.

Function	LED Behavior	Description
Factory Reset	All 8 LEDs will flash 3 times	Reset the sound bar to the factory default settings. To perform a Factory Reset, Press and Hold the Bluetooth (⌘) and Volume Down (—) buttons for 5 seconds. Note: This will erase all settings and preferences that you have set.
VIZIO TV Remote Control	← Enable VIZIO TV Remote Disable VIZIO TV Remote →	Enable/disable the use of a VIZIO TV remote control to power on and adjust the volume of the sound bar. To enable/disable this function, Press and Hold the Power (⏻) and Volume Up (+) buttons for 5 seconds.
Energy Star/ Ecomode	← Enable Eco Power Disable Eco Power →	When the Eco Power setting is enabled, the sound bar will automatically power down after a period of inactivity. When disabled, the sound bar will remain powered on until you turn it off. To enable/disable this function, Press and Hold the Power (⏻) and Volume Down (—) buttons for 5 seconds. Note: Eco Power setting is enabled by default.

PROGRAMMING THE SOUND BAR

- You can program your sound bar to accept TV remote IR commands. Press the Menu button on the remote, then use the Up/Down buttons to navigate to Prg Remote. Use the Next/Previous buttons to toggle through Learn Vol -, Learn Vol +, and Learn Mute.

Function	LED Behavior	Description
Learn Volume Down Learn Vol-	(Waiting to learn) Flash from bottom to top and back continuously.	Press the Play button to put the sound bar into learning mode. While the sound bar is in learning mode, press the Volume Down button on the TV remote control. All of the LED Indicators on the sound bar will flash two times indicating that it has successfully recognized the TV remote.
Learn Volume Up Learn Vol+		Press the Play button to put the sound bar into learning mode. While the sound bar is in learning mode, press the Volume Up button on the TV remote control. All of the LED Indicators on the sound bar will flash two times indicating that it has successfully recognized the TV remote.
Learn Mute Learn Mute		Press the Play button to put the sound bar into learning mode. While the sound bar is in learning mode, press the Mute button on the TV remote control. All of the LED Indicators on the sound bar will flash two times indicating that it has successfully recognized the TV remote.

- Point both the sound bar and TV remotes towards the front of the sound bar when programming.

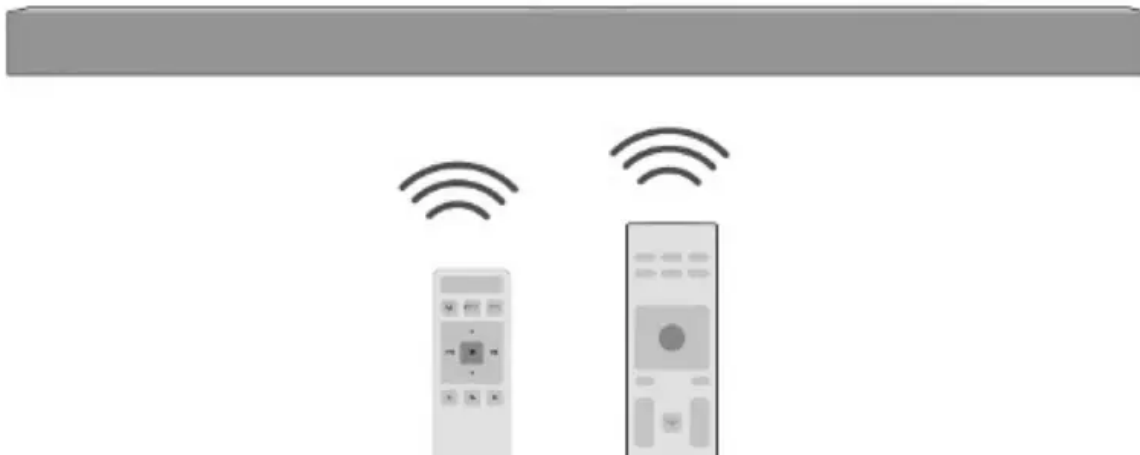

Turn off your TV speakers when programming your sound bar.

BLUETOOTH AUDIO PAIRING

To pair the sound bar with a Bluetooth device:

1. Press and hold the Bluetooth button on the sound bar for five (5) seconds or select the BT Pair option from the display remote menu. When the sound bar is in Bluetooth Pairing Mode, the LED Indicators on the Display Panel on the front of the Sound Bar will light sequentially from bottom to top and back again. Once the device is paired, the LED Indicators will stop flashing.
2. You can now search for the sound bar (VIZIO SB3651n) using your Bluetooth device. For more information, refer to the user documentation that came with the device.
3. Play audio from your Bluetooth device. Volume can be controlled on your source device and the sound bar.

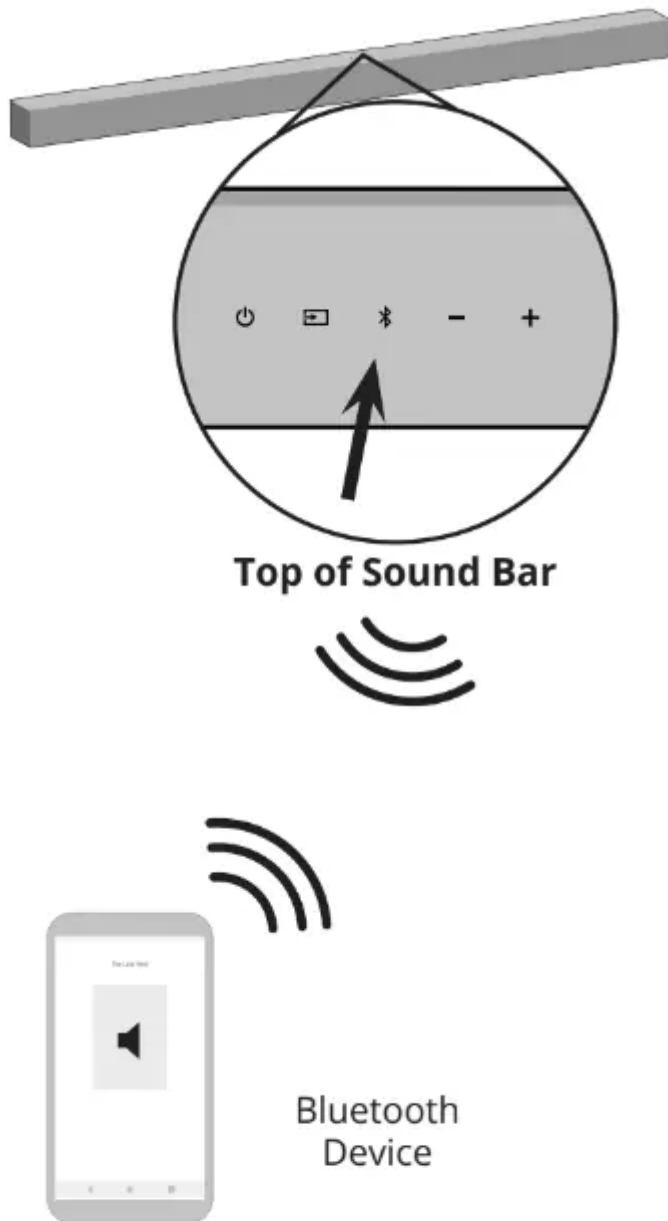

USING BLUETOOTH MODE

Your sound bar supports music streaming from smartphones, tablets, and computers with Bluetooth capability. Device compatibility will vary, see your device's documentation for more information. Once you have paired your source device to the sound bar, as long as you stay within range of the sound bar, your device should remain paired. If the input is changed, the Bluetooth device will disconnect. If the source is changed back to Bluetooth, any paired Bluetooth device will reconnect automatically.

Your sound bar is not equipped with a microphone, so it cannot operate as a hands-free device for a smartphone.

Maximizing Signal

- A Bluetooth signal has a range of up to 30 feet. Keep in mind that Bluetooth is a compressed audio format, so streamed music may lose some integrity when compared to a wired connection.
- Try the following if your sound quality is less than optimal:
 - If you hear any break-up or disconnect while streaming music from your device, move the source device closer to the sound bar.
 - Be sure that there are no solid obstructions in the line-of-sight between the sound bar and the source device.
 - Other wireless devices can affect Bluetooth range, including wireless security cameras, wireless video baby monitors, cordless phones, and microwave ovens. Turning off or moving these devices may improve Bluetooth range.

Reduce the volume levels on your device and on the sound bar before pressing Play. High volume levels can damage your hearing.

ADVANCED SETUP

Back of Sound Bar

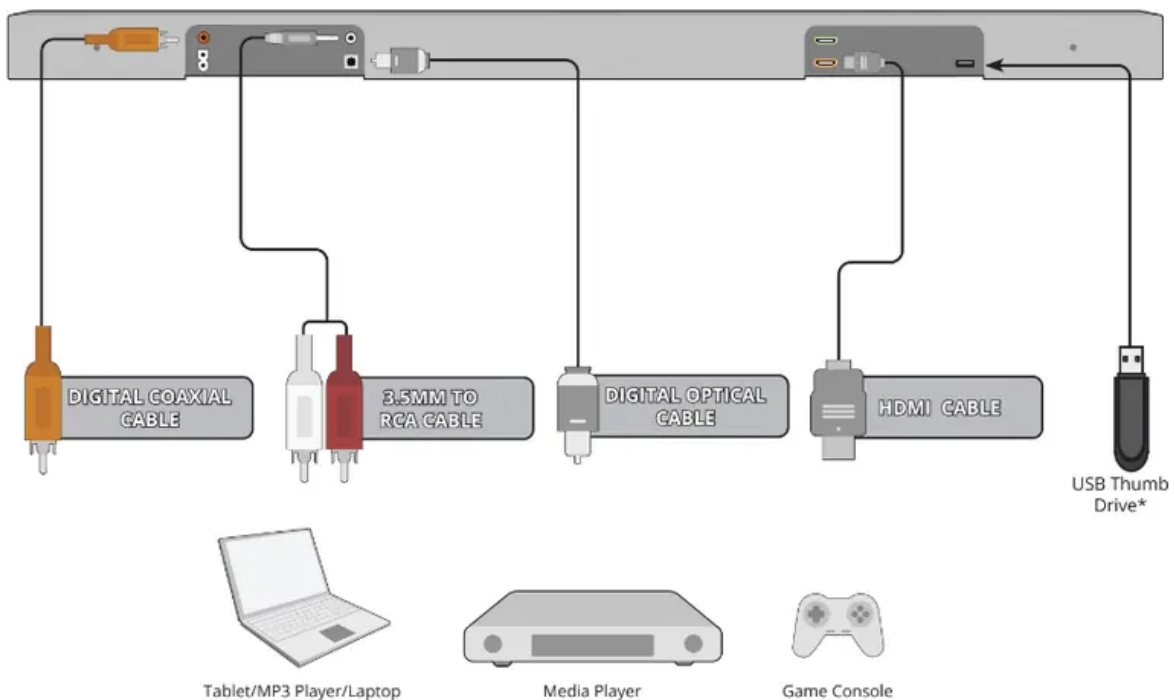

* Supports .WAV and .MP3 file format playback only.

ADVANCED SETUP - HDMI

HDMI cables transmit both audio and video. To view video from these devices, turn the sound bar on, then set the sound bar input to HDMI In. Set your TV input to the HDMI port to which the sound bar is connected.

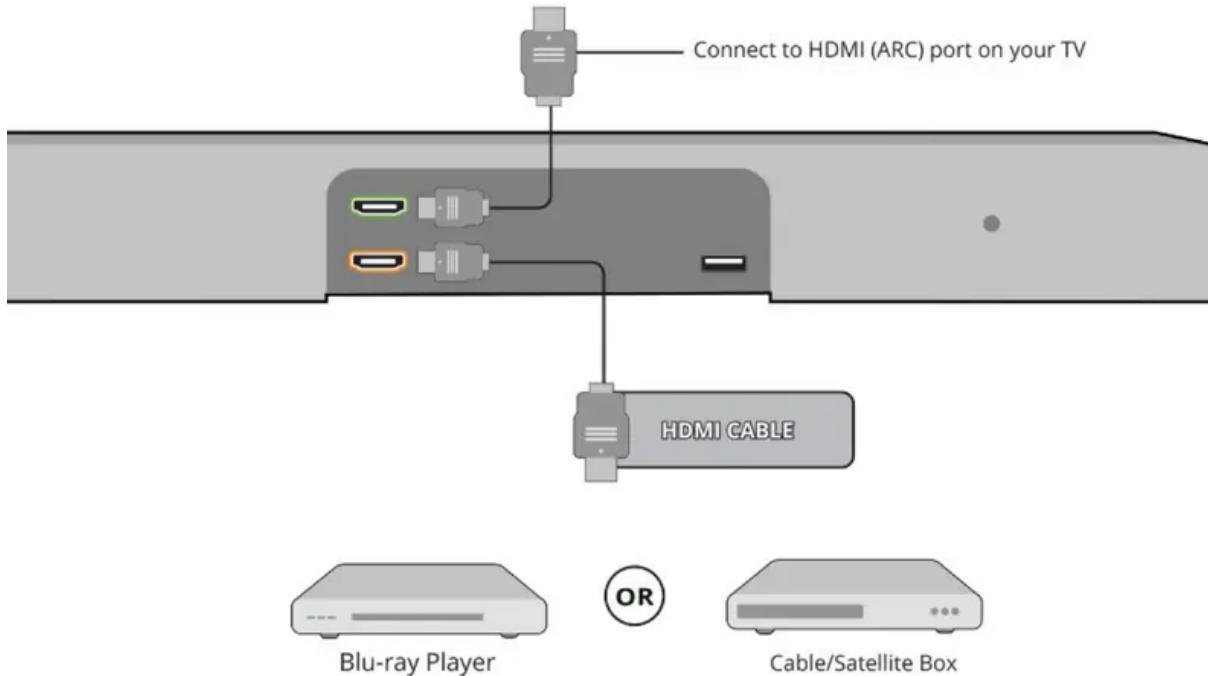

CONNECTING WITH HDMI ARC

What is HDMI Audio Return Channel (ARC)?

- Using HDMI ARC, your TV can send audio to the sound bar using an HDMI cable.
- You will need to connect your sound bar to your TV's HDMI ARC port using an HDMI cable that is ARC compatible.
- To connect using HDMI*:
 1. Connect one end of the HDMI cable to the HDMI 1 (ARC) port on the back of your TV.
 2. Connect the other end to the HDMI OUT (ARC) port on your VIZIO Sound Bar.
 3. From the AUDIO menu on your TV, change the Digital Audio Setting to Dolby Digital or Bitstream.
 4. From the SYSTEM menu, enable CEC and ARC (SAC)† functions.
 5. From the CEC menu, select Device Discovery to register the sound bar with the TV.

If you want to use the volume buttons on the TV remote control to control the sound bar, enable System Audio Control from the CEC menu.

* The following steps are for use with a VIZIO TV, steps may differ by TV manufacturer. See your TV's user manual for more information.

† CEC Function naming may differ by TV manufacturer. See your TV's user manual for more information.

Back of TV*

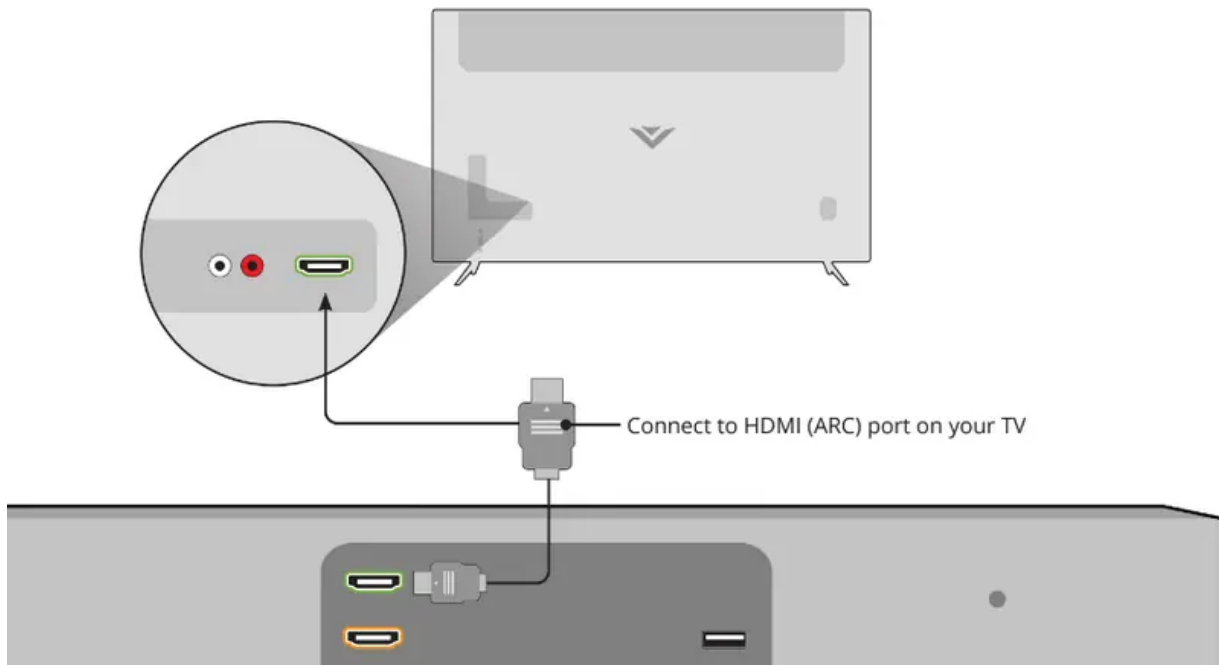

* HDMI ARC port location may differ by TV manufacturer. See your TV's user manual for more information.

CONNECTING A SUBWOOFER

- The subwoofer has already been paired with the sound bar by VIZIO. However, the subwoofer may need to be re-linked to the sound bar if there is no sound coming from the subwoofer.



- *What does pairing mean? Pairing means to wirelessly connect.*



1. First confirm that the power LED is illuminated. Press and hold the ON/OFF button on the back of the subwoofer for 5 seconds. The LED on the back of the subwoofer will begin to blink

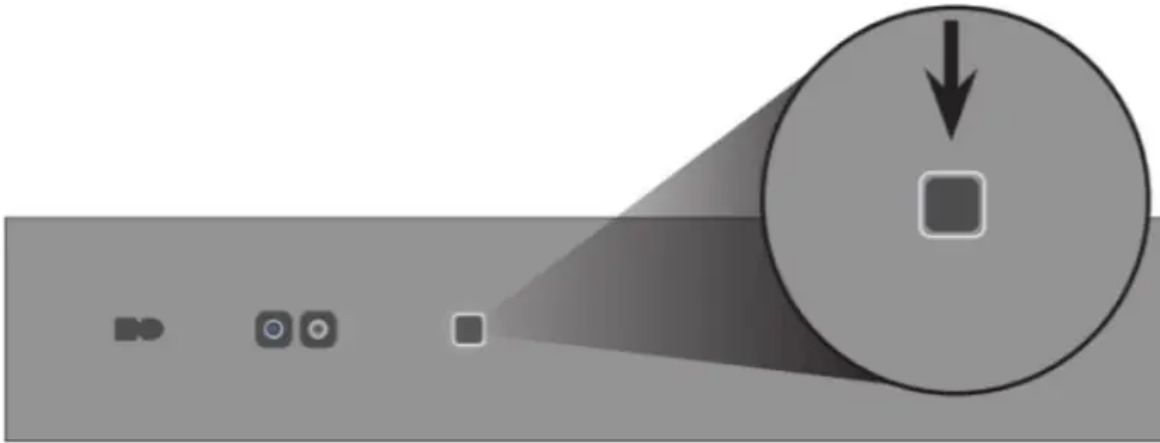

Back of subwoofer

2. Press and hold the Power button on the top of the sound bar for 5 seconds. The LED indicators on the front will flash 3 times. The subwoofer is now linked with the sound bar.

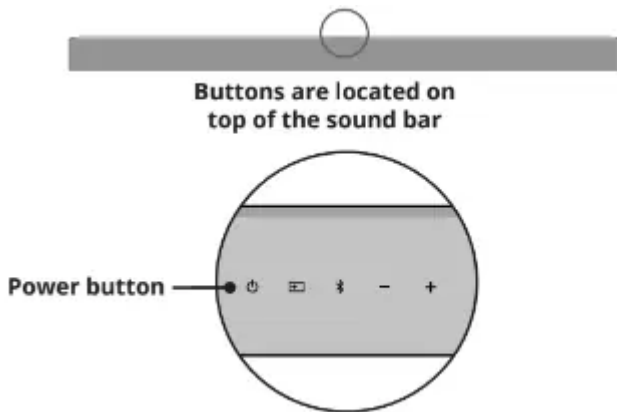

WALL-MOUNTING THE SOUND BAR

1. Insert the two wall-mount screws into the wall-mount screw holes, and then tighten them with a Phillips screwdriver.



2. Place the included wall mounting template against the wall under your TV. Mark the two bracket holes using a pencil.



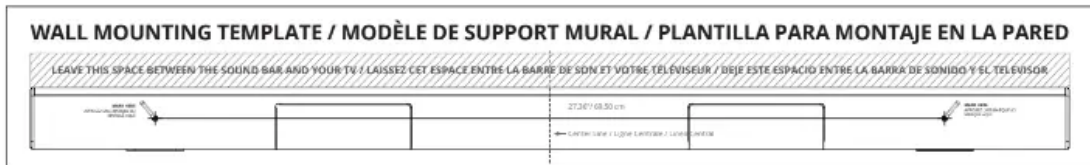

3. Be sure your screws are attached to wood studs, drywall anchors (for drywall), or concrete anchors (for 3 brick/concrete walls).

Screws for attaching the brackets to the wall are not included. Choose the screw type and length appropriate to your home's construction. If in doubt, consult a professional installer.

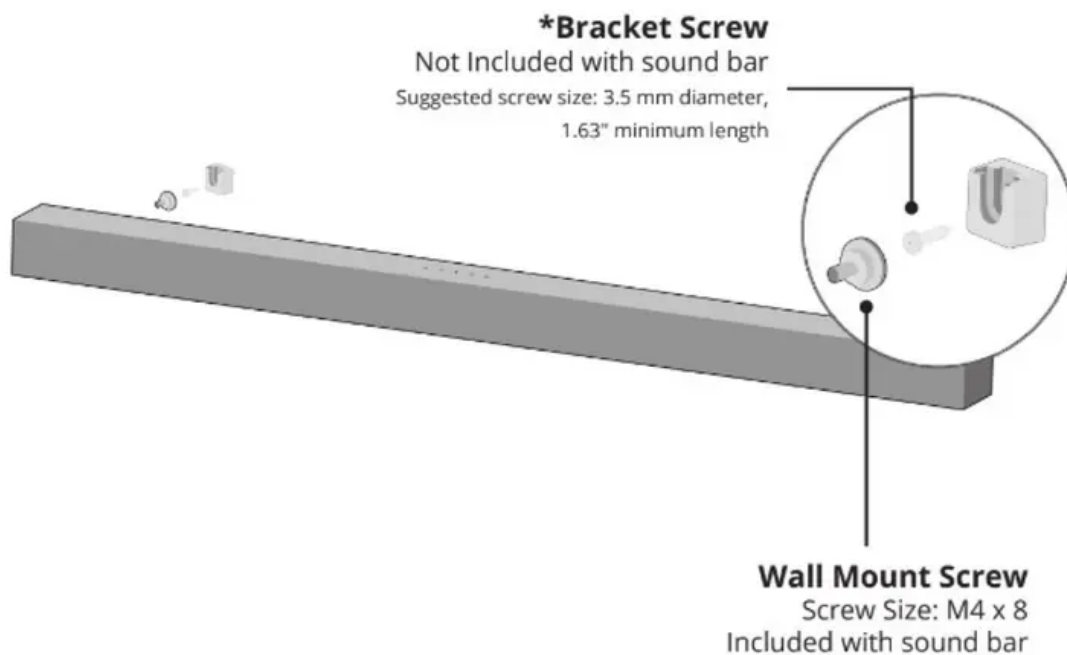

If you are unfamiliar with power tools or the layout of electrical wiring in the walls of your home, consult a professional installer.

* Do not use any of the included screws for the wall mount installation. These are not intended for mounting.

WALL-MOUNTING THE SATELLITE SPEAKERS

- To wall-mount the satellite speakers:
 1. Attach the wall mount screw to the back of the satellite speaker.
 2. Secure the wall mount bracket to the wall. Bracket screw is not included.
 3. Slide the speaker on to the wall bracket. Ensure the wall mount screw is secured within the bracket grooves.
- Be sure your screws are attached to wood studs or drywall anchors (for drywall) or concrete anchors (for brick/concrete walls). Wall mounting hardware is not included.

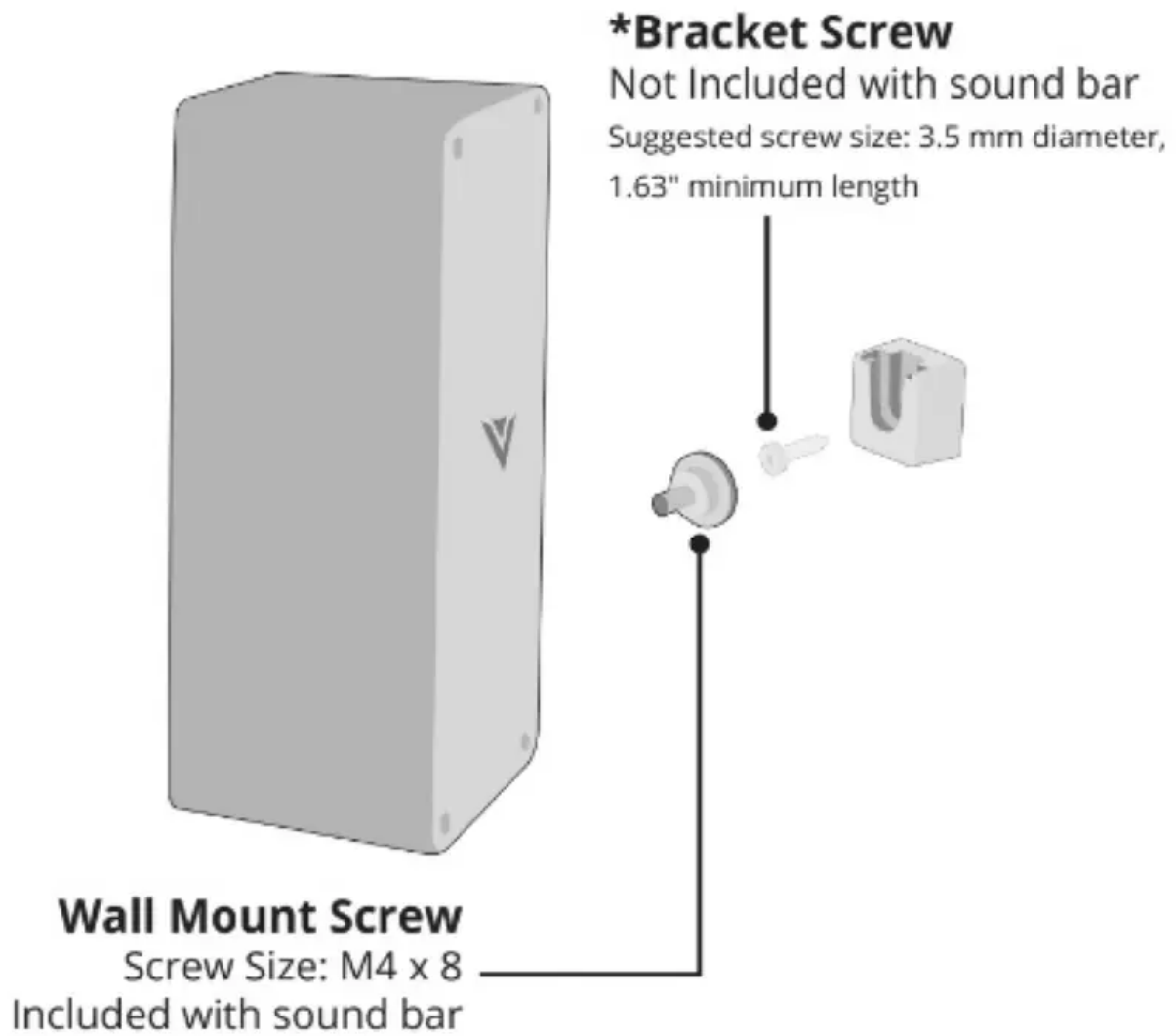

If you are unfamiliar with power tools or the layout of electrical wiring in the walls of your home, consult a professional installer.

* Do not use any of the included screws for the wall mount installation. These are not intended for mounting.

HELP & TROUBLESHOOTING

- There is no power.
 - Press the POWER button on the remote control or on the top of your Sound Bar.
 - Ensure the power cord is securely connected.
 - Plug a different device into the electrical outlet to verify that the outlet is working correctly.

- There is no sound.
 - Increase the volume. Press Volume Up on the remote control or on the top of your Sound Bar.
 - Press MUTE on the remote to ensure the Sound Bar is not muted.
 - Press INPUT on the remote or on the top of your Sound Bar to select a different input source.
 - When using either of the Digital Inputs, if there is no audio: (A) Try setting the TV output to PCM or (B) Connect directly to your Blu-ray/other source, some TVs do not pass through digital audio.
 - On digital inputs, the input LEDs will flash rapidly if an unsupported format is present. Set the source to output PCM.
 - Your TV may be set to variable audio output. Confirm that the audio output setting is set to FIXED or STANDARD, not VARIABLE. Consult your TV's user manual for more detailed information.
 - If using Bluetooth, ensure that the volume on your source device is turned up and that the device is not muted.
- I hear buzzing or humming
 - Ensure all cables and wires are securely connected.
 - Connect a different source device (TV, Blu-ray player, etc) to see if the buzzing persists. If it does not, the problem may be with the original device.
 - Connect your device to a different input on the Sound Bar.
- The remote isn't working.
 - Replace the remote batteries with new ones.
 - Point the remote directly at the center of the Sound Bar when pressing a button.
 - If using a Bluetooth connection, some of the buttons on the remote may not be supported by the streaming application. (e.g., Pandora doesn't support the Back button.)

SPECIFICATIONS

- **Sound Bar:**
 - Two 1.66" x 2.77" (42.3 x 70.3 mm) Full Range Driver for each channel (1 for left, 1 for right)
 - One 1.38" x 2.60" (35 x 66 mm) Full Range Driver for center channel

- **Satellite Speakers:**
 - Two 1.68" x 2.78" (42.7 x 70.7 mm) Full Range Driver for Each
- **Subwoofer:**
 - One 5" (127 mm) Subwoofer Driver
- **Connections:**
 - One 3.5mm Stereo Audio HDMI In
 - One Optical (Toslink) HDMI Out (Arc)
 - Digital Coaxial Bluetooth
 - Bluetooth One USB (Supports .WAV and .MP3 format only)
- **Sound Pressure Level* (System):** 101 dB
- **Frequency Response (System):** 50 Hz - 20 KHz
- **Voltage:** 120 VAC, 60 Hz
- **Compliances:** cTUVus / FCC Class B / ICES-003 /CEC / Energy star

Warning

This content is compiled from multiple sources and is provided for reference purposes only. It may not be complete or fully applicable to all situations. If you are unable to resolve your issue, please contact the product manufacturer or an authorized service provider for official support.