

## Sound Bar Quick Guide

### Installing and using the Product

1. Connect the sound bar to your TV via an optical cable or an HDMI cable.

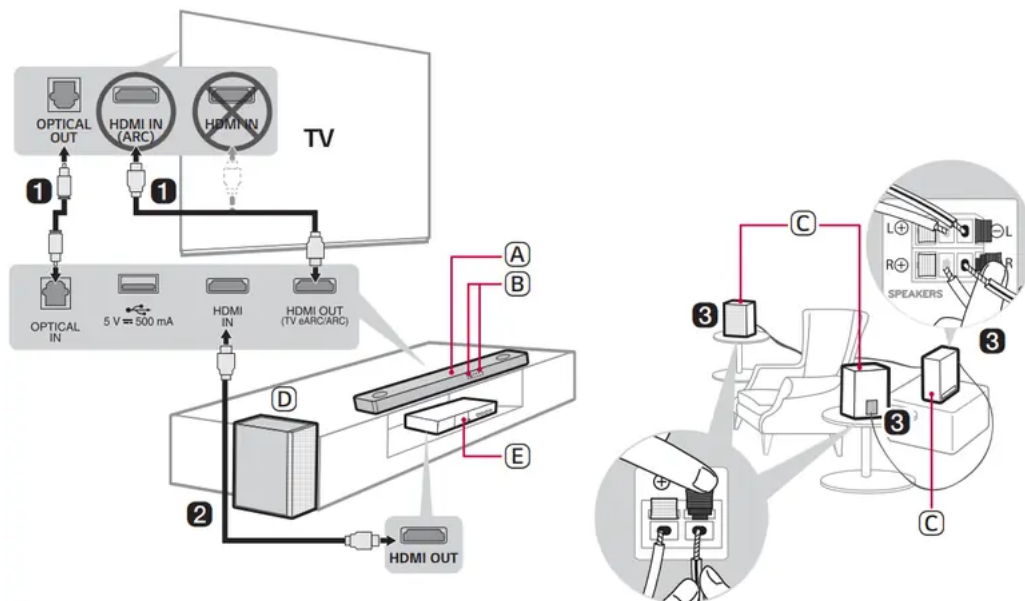





- A. Sound bar
- B. Remote Control Receiver / Status Display
- C. Rear Speakers / Wireless Receiver (Sold separately, SPK8-S)
- D. Wireless Subwoofer - Install it close to the sound bar.
- E. External Device - (Blu-ray player, game console, etc.)

2. If you are using an external device (ex. Blu-ray player, game console, etc.), connect it to the sound bar via an HDMI cable.
3. If you purchased the rear speakers and wireless receiver separately, connect the rear speakers to the wireless receiver via a speaker cable. When connecting the rear speakers to the wireless receiver, connect the black striped cable to the negative terminal of each speaker and the remaining cable to the positive terminal of each speaker.
4. Connect to power in the following order: wireless subwoofer → wireless receiver → sound bar. Then, turn on the sound bar. When the connection is automatically established with the sound bar, the LEDs on the wireless subwoofer and the wireless receiver will light up in green. (→ See “Connecting the Product” .)

## 5. Using the product with your TV ( → See “Connecting to the TV” )

1. Press the Function  button repeatedly until “OPT/HDMI ARC” appears on the status display.
2. On your TV's settings, set the output speaker to [HDMI ARC], [Optical], or [External Speaker].
3. When the TV is properly connected to the product, “OPT”, “ARC”, or “E-ARC” will appear on the status display with a sound.

## 6. Connecting the product to your smartphone via Bluetooth ( → See “Connecting via Bluetooth” on . )

1. Tap the Settings  button on your smartphone and select  Bluetooth. Turn on the Bluetooth function. (  Off >  On )
2. Press the Bluetooth pair  button. After a moment, you will see “BT READY” on the status display.
3. Find and tap the product on your smartphone. The product appears as “LG SPD7Y (XX)”.
4. When the product is connected to your smartphone via Bluetooth, you can see the status display change from “PAIRED” → “Connected Bluetooth device name” → “BT”.

## 7. Connecting to the LG Sound Bar app ( → See “Connecting with a Smartphone via LG Sound Bar app” . )

1. Find and install the LG Sound Bar app on Google Play or App Store from your smartphone.
2. You can get more information regarding its use by selecting [Help] in [Setting].

# Installation

## Connecting the Product

You can enjoy a richer sound by connecting the sound bar to the wireless subwoofer.

### Connecting the wireless subwoofer automatically

After completing installation, the wireless subwoofer will automatically be connected to the sound bar. Connect the sound bar to the subwoofer in the following order.

1. Plug the power cable into the wireless subwoofer.
2. Plug the power cable connected to the wireless subwoofer into an outlet.
3. Plug the power cable into the AC adapter.

4. Connect the AC adapter cable to the DC IN (AC adapter input) terminal on the back of the product.
5. Plug the power cable connected to the AC adapter into an outlet.

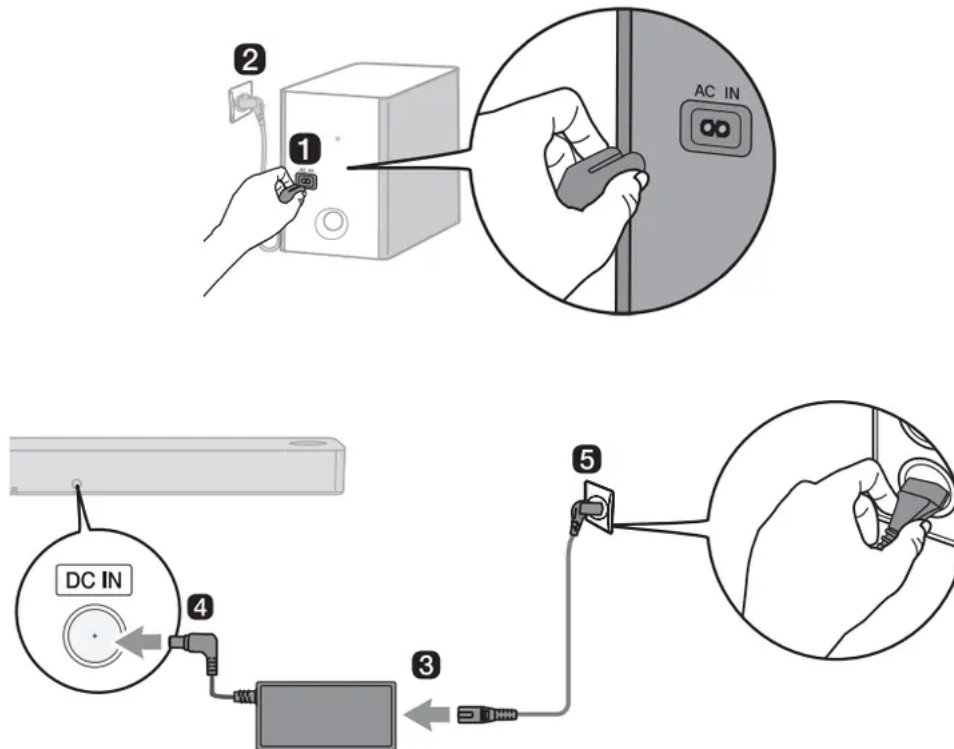

6. When the connection is automatically established, you will see the LED on the back of the wireless subwoofer light up in green.

### Checking the connection with the LED on the back of the wireless subwoofer

You can check the connection status by looking at the LED on the back of the wireless subwoofer.

LED Color	Status
Blinking green	Connecting in progress
Green	Connected successfully
Red	Bad connection, or the subwoofer is in standby
Off	Power cable not connected

### Connecting the wireless subwoofer manually

If you see a red LED on the back of the wireless subwoofer, it means that the sound bar is not connected to the subwoofer. If this is the case, connect them in the following order.

1. Press the Power  button on the sound bar to turn it off.
2. Press the Pairing button on the back of the wireless subwoofer. Check if the LED on the back of the subwoofer is blinking green. If you still see a red LED on the wireless subwoofer, press and hold the button on the back of the subwoofer again.

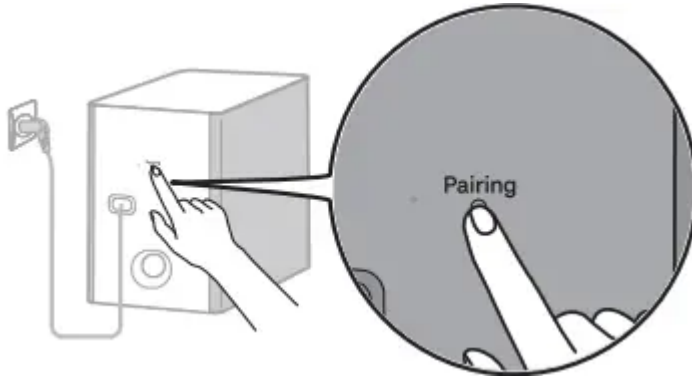

3. Press the Power  button on the sound bar to turn it on.
4. When the connection is established, you will see the LED light on the back of the wireless subwoofer light up in green.

#### Note

- Install the sound bar as close to the wireless subwoofer as possible. The closer the distance between the sound bar and the wireless subwoofer, the better the sound quality.
- Please ensure there are no obstacles between the sound bar and the wireless subwoofer.
- To prevent wireless interference, maintain a distance of at least 1 m (3.3 ft) between the sound bar or the wireless subwoofer and any peripheral devices that generate strong electromagnetic waves (ex. wireless routers, microwave ovens, etc.)

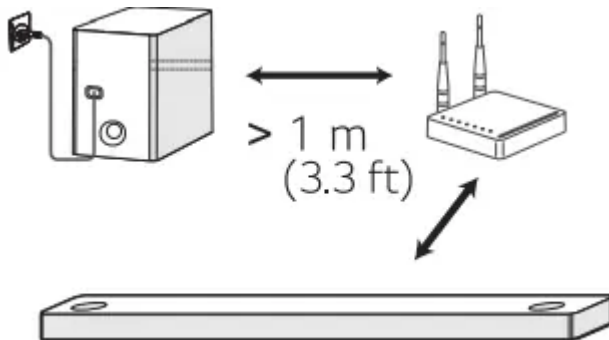

#### Connecting the rear speakers to the wireless receiver (SPK8-S, sold separately)

##### Automatic connection

After completing installation, the wireless receiver will automatically be connected to the sound bar. Connect the sound bar to the wireless receiver in the following order

1. Connect the speaker cables to the corresponding terminals on the rear speakers (left, right). Connect the black striped cable to the negative terminal and the other cable to the positive terminal.
2. Connect the speaker cables on the rear speakers (left, right) to the wireless receiver

Receiver Terminal Color	Speaker Position
Blue	L Left rear
Gray	R Right rear

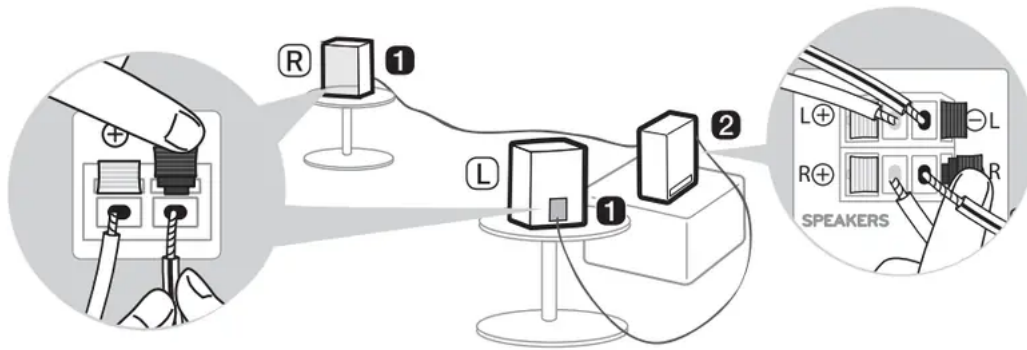

3. Plug the wireless receiver power cable into an outlet.
4. Press the Power  button on the sound bar to turn it on.
5. When the connection is automatically established, you will see the LED on the front of the wireless receiver light up in green.

#### Checking connection status with the LED color

You can check the connection status with the LED on the front of the wireless receiver.

LED Color	Status
Blinking green	Connecting In progress
Green	Connected successfully
Red	Bad connection, or the receiver is in standby
Off	Power cable not connected

### Manual connection

If you see a red LED on the front of the wireless receiver, it means that the sound bar is not connected to the receiver. If this is the case, connect them in the following order.

1. Press the Power  button on the sound bar to turn it off.
2. Press the PAIRING button on the back of the wireless receiver. Check if the LED on the front of the wireless receiver is blinking green.

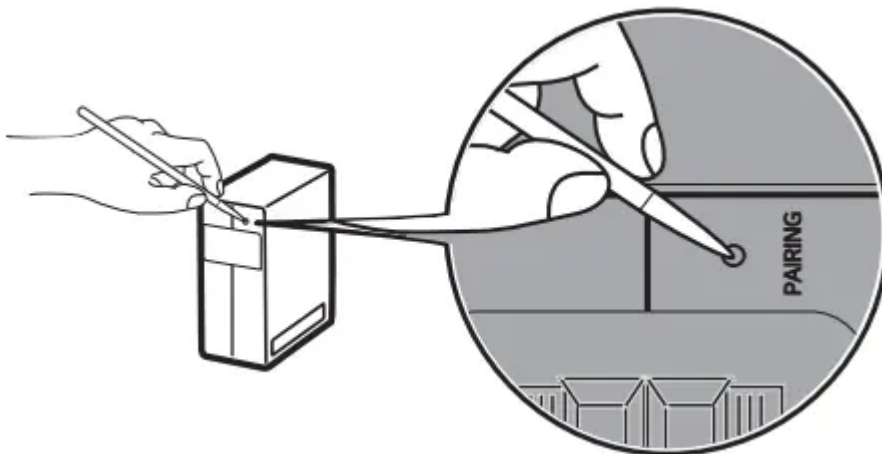

3. Press the Power  button on the sound bar to turn it on.
4. When the connection is established, you will see the LED light on the front of the wireless receiver light up in green.

### Note

- Keep the rear speakers at least 30 cm (11.8 inch) away from the TV or monitor.
- To prevent wireless interference, maintain a distance of at least 1 m (3.3 ft) between the sound bar or the wireless receiver and any peripheral devices that generate strong electromagnetic waves (ex. wireless routers, microwave ovens, etc.)

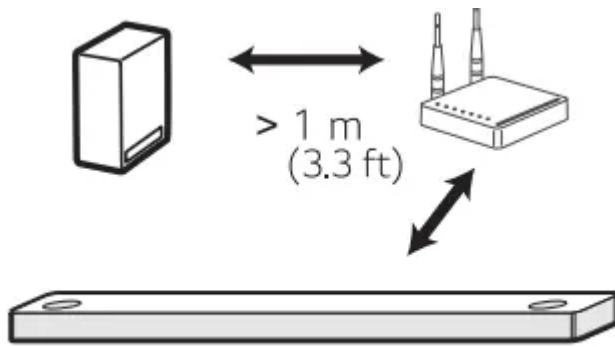

### Attaching the ferrite core (optional)

A ferrite core may not be provided depending on national standards.

#### Attaching the ferrite core to the speaker cables

Attach the ferrite core to the cables to reduce radio noise.

1. Pull Part [a] to open the ferrite core.
2. Wind the wireless receiver's speaker cables twice around the ferrite core.
3. Close the ferrite core until you hear a click.

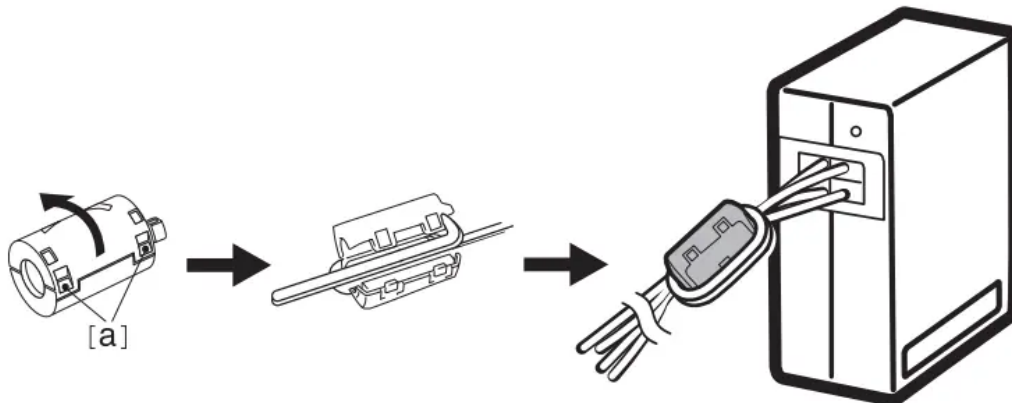

### Setting up surround sound

- The surround sound function allows you to hear immersive 3D sound produced by multiple audio channels from the speakers, regardless of the channels in the originally recorded content.
- For example, if you listen to music recorded in 2.0 channels with standard sound effects while the wireless rear speakers are connected, you can hear the following difference.

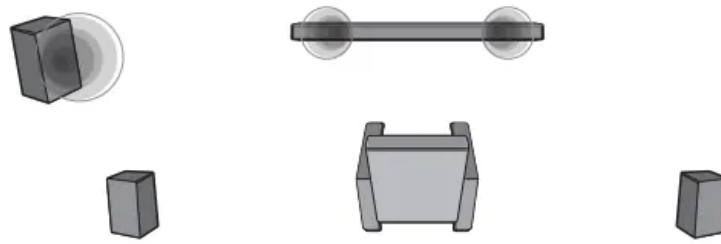

When the surround sound is off

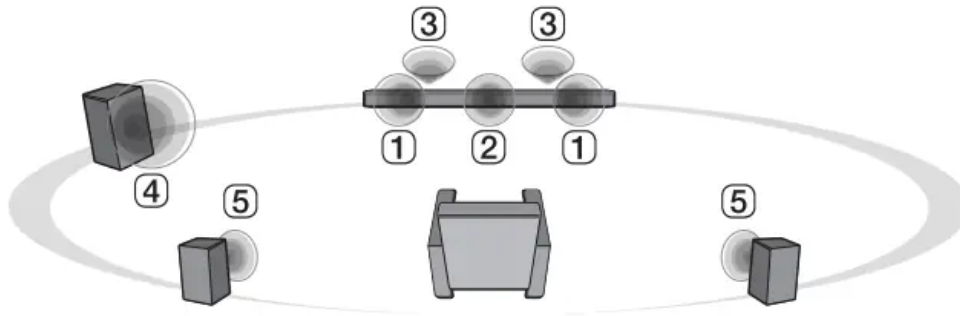

When the surround sound is on

Note: Speaker positions are as follows.

A	Front speakers
B	Center speaker
C	Top speakers
D	Subwoofer
E	Rear speakers

Turning surround sound on/off

1. Press Settings  button. The product enters the setting mode and you can see “OFF-AUTO POWER” or “ON-AUTO POWER”.

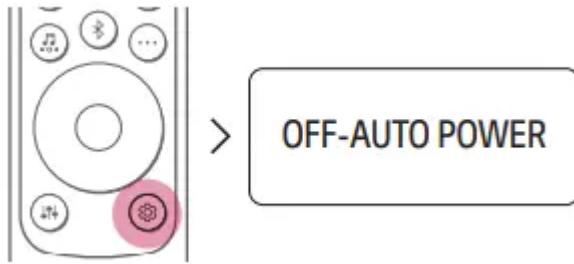

2. While the “OFF-AUTO POWER” or “ON-AUTO POWER” is scrolling in the status display, press Left/ Right button to select the surround sound setting. You can see the status of the surround sound, “OFFSURROUND” or “ON-SURROUND”

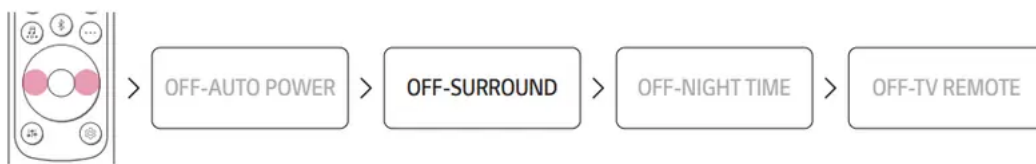

3. While the “OFF-SURROUND” or “ON-SURROUND” is scrolling in the status display, press Up/Down button to turn on or off the surround sound.

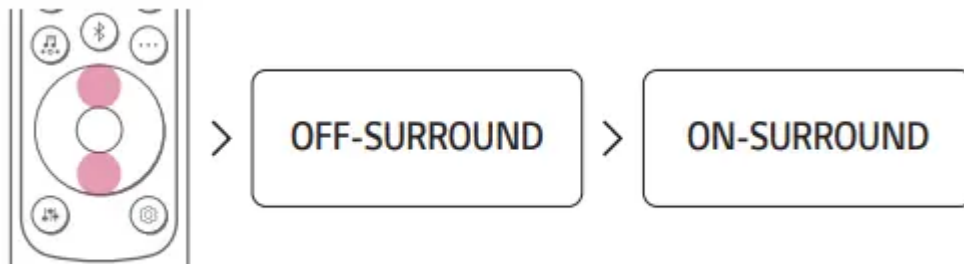

Speaker sound based on input channels

Sound Effects	Input	Output	
		Rear speakers not connected	Rear speakers connected
<b>AI SOUND PRO</b> Sound customized with artificial intelligence	2.0 channels		
	5.1 channels or more		
<b>STANDARD</b> You can enjoy optimized sound.	2.0 channels		
	5.1 channels or more		
<b>MUSIC</b> Sound enriched with MERIDIAN technology	2.0 channels		
	5.1 channels or more		
<b>CINEMA</b> Cinematic 3D sound	2.0 channels		
	5.1 channels or more		
<b>CLEAR VOICE</b> Voice sound clear, improving the quality of voice sound	2.0 channels		
	5.1 channels or more		

Sound Effects	Input	Output	
		Rear speakers not connected	Rear speakers connected
<b>SPORTS</b> Realistic sound like in a stadium	2.0 channels		
	5.1 channels or more		
<b>GAME</b> Optimized sound for game	2.0 channels		
	5.1 channels or more		
<b>BASS BLAST (BASS BLAST+)</b> Sound with reinforced bass	2.0 channels		
	5.1 channels or more		

# Exploring the Product

## Front

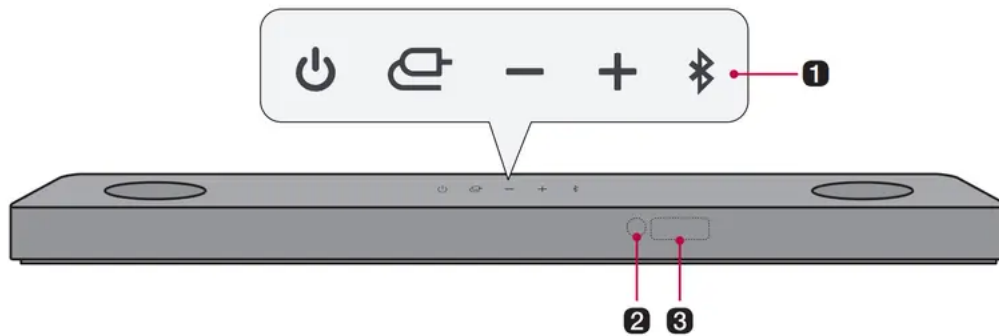



1.

Power  : This turns the product on/off.

Function  : Press the button repeatedly to select the desired function or input mode

Status Display	Description
OPT/HDMI ARC	Connects the product to a TV that supports an optical cable, ARC, E-ARC, or LG Sound Sync
BT	Connects the product via <b>Bluetooth</b>
LG TV	Connects the product to a TV that supports LG Sound Sync (Wireless)
HDMI	Connects the product to an HDMI input port
USB	Connects the product to a USB storage device

Volume   : This adjusts the speaker volume with levels 0 to 40.

Bluetooth pair  : It allows you to pair your Bluetooth device such as a smartphone to this product for three minutes. (→ See “Connecting via Bluetooth” on .) It allows you to pair your LG TV to this product for three minutes. (→ See “Connecting with LG Sound Sync (Wireless)” on .)

2. Remote Control Receiver: This receives wireless signals from the remote control.

**3. Status display:** Options such as input mode and volume are displayed in text.

- If there is no active input for 15 seconds, the status display will automatically dim. When you press the button, the status display will light up again.

Note: To reduce power consumption, the product will automatically turn off after 15 minutes of no input signal from an external device.

## Back

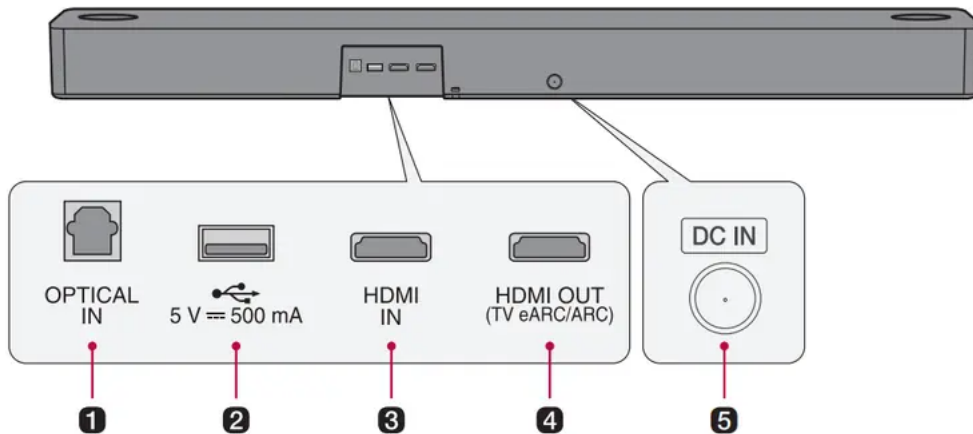

1. OPTICAL IN: Plug in an optical cable to connect the TV to the product.
2. USB port: Plug in a USB storage device to play music with the product.
3. HDMI IN: Plug in an HDMI cable to connect an external device to the product.
4. HDMI OUT (TV eARC/ARC): Plug in an HDMI cable to connect the TV to the product.
5. DC IN: Plug in the AC adapter. to the product.

## Exploring Remote Control

You can use the remote to control all functions of the product, from turning the power on/off to enabling cinematic sound.

## Replacement of Battery

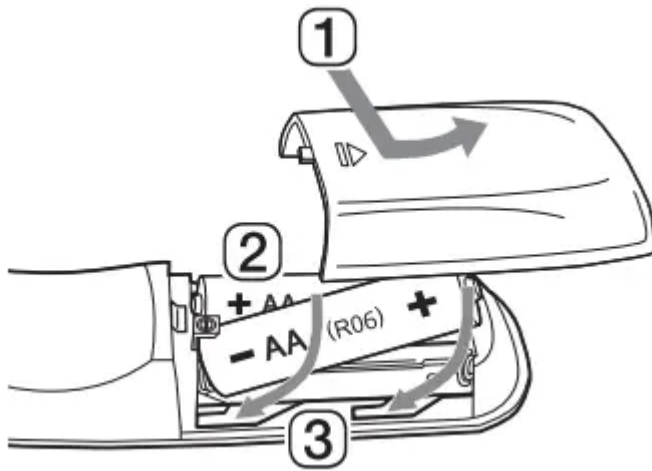



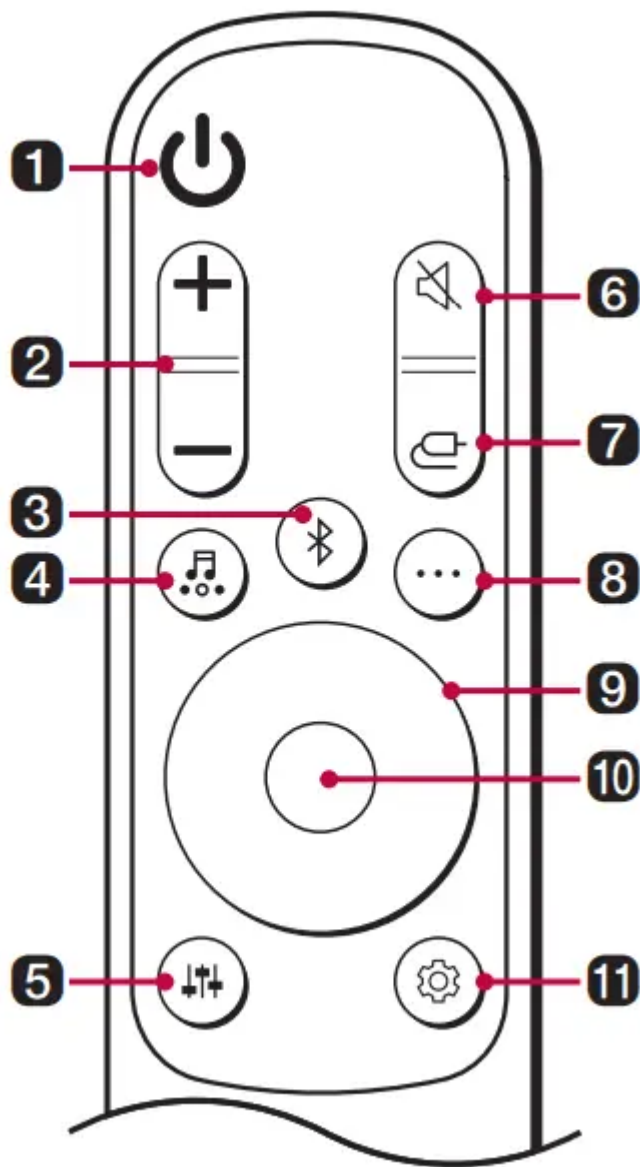

Use AA 1.5V batteries. Replace the two batteries by inserting them into the remote control in accordance with the directions indicated.

1. Open the battery cover on the back of the remote control.
2. Insert the batteries with the + and – ends corresponding to the markings.
3. Close the battery cover.



Risk of fire or explosion if the battery is replaced by an incorrect type.



1. Power  : Turns the product on/off
2. Volume   : Adjusts the sound volume
3. Bluetooth pair  : It allows you to pair your Bluetooth device such as a smartphone to this product for three minutes. (→ See “Connecting via Bluetooth” on .) It allows you to pair your LG TV to this product for three minutes. (→ See “Connecting with LG Sound Sync (Wireless)” on .)
4. Sound Effects  : Press the button to select the desired sound field.

Status Display	Description
AI SOUND PRO	Artificial intelligence selects the optimal sound settings to suit your content.
STANDARD	You can enjoy optimized sound.
MUSIC	Experience premium sound technology from MERIDIAN.
CINEMA	Play content with 3D sound similar to a movie theater.
CLEAR VOICE	Voice sound clear, improving the quality of voice sound
SPORTS	Realistic sound like in a stadium
GAME	Optimized sound for game
BASS BLAST (BASS BLAST+)	Bass sounds are enhanced.

- Sound effects cannot be changed when Dolby Atmos® or DTS:X® are enabled. Pressing the Sound Effects  button, will result in “NOT SUPPORTED” appearing on the status display.

5. Sound Tuning  : This adjusts the sound level of the connected speaker. Press the Sound Tuning  button and then Left/Right button to select the desired speaker before you press the Up/Down button to increase/decrease the sound volume.

Status Display	Connected Speaker	Adjustable Range
WF	Subwoofer	-15 - 6
C	Center speaker	-6 - 6
OVC	Top speaker	-6 - 6
R	Rear Speaker	-6 - 6
TRE	Front speaker (treble)	-5 - 5
BAS	Front speaker (bass)	-5 - 5

- Adjusting rear speakers level is applied only when the rear speakers are connected.

6. Mute  : This turns off the sound from the product.

7. Function  : Press the button repeatedly to select the desired input mode or function.

8. Information  : View the connected input source or Bluetooth information.

Input Mode/Function	Shown on Status Display
BT	Connected <b>Bluetooth</b> device name
OPT/ARC/E-ARC/HDMI	Current sound source
USB	Current sound filename

9. Up/Down/Left/ Right 

- These buttons are used to adjust the settings of the convenient functions.

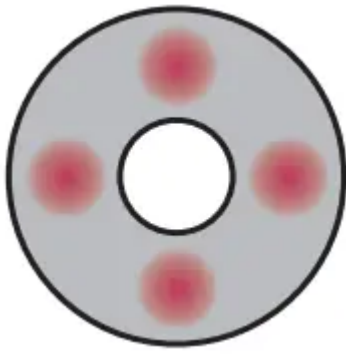

- Up/Down: This scrolls through the folders on the USB storage device. You can press the button to select the desired folder.
- Left/Right: If you play a previous song, press Left button. If you play a next song, press Right button.

#### 10. Play/Pause

If you play or pause a song, press this button.

- When listening to music on a USB storage device, you can select the play mode by pressing the button for 3 seconds or longer, then press Up/Down to select the desired Repeat option.

Status Display	Description
OFF	Plays the files in order, then ends playback
ONE	Plays the current file repeatedly
FOLDER	Only plays the files in the folder on a loop
ALL	Plays all files on a loop
SHUFFLE	Plays a random file until all files are played, then ends playback

#### 11. Settings

It allows you to adjust the settings of this product: AUTO POWER, SURROUND, NIGHT TIME, TV REMOTE. Press Settings  button and select the setting by using Left/Right button before you press the Up/Down button to turn on/off the setting.

- **AUTO POWER:** When the TV or an external device is turned on or off, the product will also turn on or off automatically. It is available only when the product is connected to the TV with an optical cable. (→ See “Using Auto Power” on .)
- **SURROUND:** The surround sound function allows you to hear immersive 3D sound produced by multiple audio channels from the speakers, regardless of the channels in the originally recorded content. (→ See “Turning surround sound on/ off” on .)
- **NIGHT TIME:** This reduces the general sound volume, but raises the volume of soft and delicate sounds. This is useful when enjoying music or a movie late at night. (→ See “Using Night Time” on.)
- **TV REMOTE:** This convenient function allows you to adjust the volume of the product with your TV’s remote control. (→ See “Controlling the product with your TV’s remote control” on .)

## Connecting to the TV

Enjoy a rich, high-quality sound by connecting the product to a TV or a beam projector. It has been designed to enhance the realism of your favorite programming, such as dramas and sports broadcasts.

### Connecting with an Optical Cable

Transmit your TV’s audio to the product by connecting it to the TV with an optical cable. You can add a variety of 3D effects to the original audio to fill the room with a deep, rich sound.

#### Watching TV after connecting with an optical cable

1. If the digital cable terminal has a cover, first remove the covers from both ends



2. Using an optical cable, connect the OPTICAL IN terminal on the back of the product to the Optical Digital Output (OPTICAL OUT) terminal on the TV as shown in the picture.

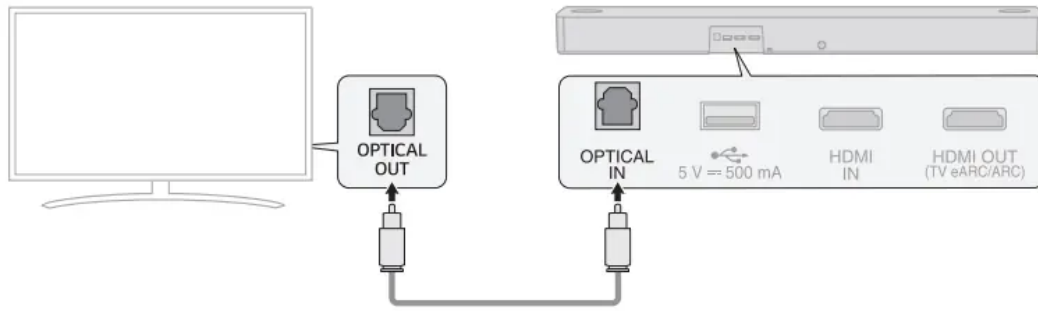

3. Press the Function  button repeatedly until “OPT/HDMI ARC” appears on the status display



4. Press the Settings button on the TV remote control to enter the [Speaker] menu and set the output speaker to [Optical] or [External Speaker]. Settings and menu items may vary depending on the TV manufacturer

### When you use an LG TV

You can adjust the volume with the LG TV remote control if the TV is connected to the product with an optical cable. You can only do so on a TV that supports the LG TV Sound Sync function. Check your TV's user manual to see if your TV is supported.

#### Functions controllable with an LG TV remote control

Volume, mute on/off



#### Note

- When the TV is properly connected to the product, “LGOPT” will appear on the status display.
- When using the product with an LG TV remote control, the volume and mute status set on the TV will automatically be applied to the product.
- You can still use the product's remote control even after connecting it to an LG TV.
- To use LG Sound Sync, you may have to change the sound setting of your TV. It may vary depending on the TV

## Connecting with LG Sound Sync (Wireless)

You can adjust the volume with the LG TV remote control if the TV is connected to the product with LG Sound Sync (Wireless). Check out the TV user manual to see if your TV is supported.

### Watching TV after connecting it wirelessly

1. Press the Function  button repeatedly until “LG TV” appears on the status display. After a moment, it will show “BT READY”. Or Press the Bluetooth  pair button. After a moment, it will show “BT READY”.

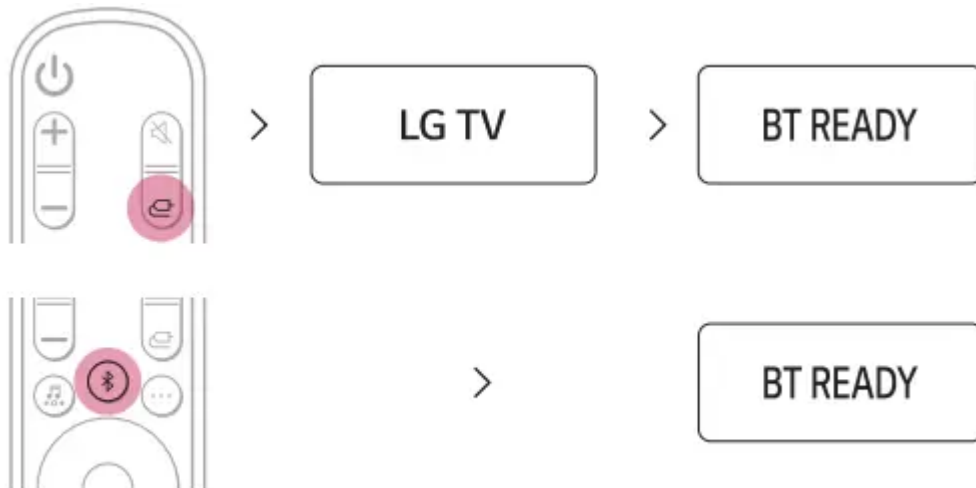

2. Press the Settings button on the TV remote control and enter the [Speaker] menu to set the output speaker to [LG Sound Sync (Wireless)].
3. When the product is connected to the TV via Bluetooth, you can see the status display change from “PAIRED” [“LG TV”

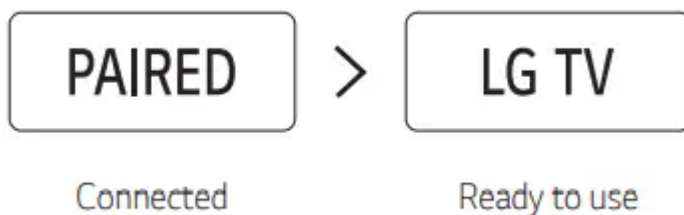



## Connecting with an HDMI Cable

You can transmit TV audio to the product by connecting the TV to the product with an HDMI cable. Add a variety of 3D effects to the original audio to fill the room with a deep, rich sound.

### Watching TV after connecting with an HDMI cable

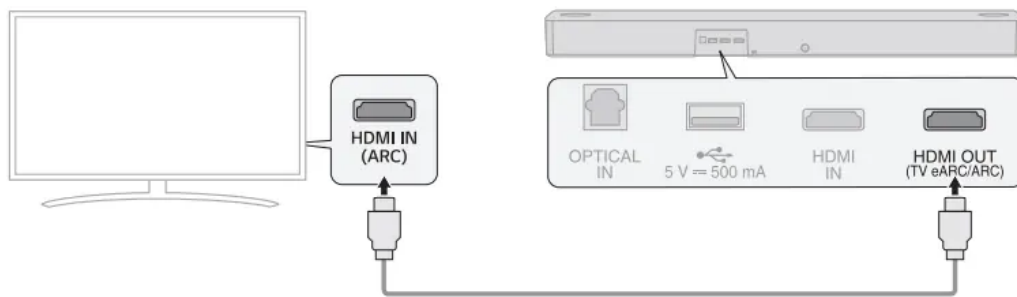
1. Using the HDMI cable, connect the HDMI OUT (TV eARC/ARC) terminal on the back of the product to the HDMI IN (ARC) terminal on the TV as shown in the picture.



2. Press the Function  button repeatedly until “OPT/HDMI ARC” appears on the status display



3. Press the Settings button on the TV remote control to enter the [Speaker] menu and set the output speaker to [HDMI ARC]. Settings and menu items may vary depending on the TV manufacturer.
4. When the TV is properly connected to the product, “ARC” or “E-ARC” will appear on the status display.

## SIMPLINK

- SIMPLINK refers to the HDMI-CEC function that allows you to use a single TV remote control to easily operate an audio device or player connected to an LG TV via HDMI.
  - Functions controllable with a SIMPLINK-compatible LG TV remote control: Power on/off, volume control, mute on/off, etc.
- For more information on how to set up SIMPLINK, consult your LG TV’s user manual.



## Connecting to an External Device

Experience movies and games in more realism by connecting the product to a device such as a game console or a Blu-ray player

## Connecting with an HDMI Cable

You can connect your TV or external device to the product with an HDMI cable for a deep, magnificent sound.

### Connecting an external device via HDMI

1. Connect an external device such as a DVD or Blu-ray player. Following the picture below, connect the HDMI OUT terminal of the device to the HDMI IN terminal on the back of the product.
2. Using the HDMI cable, connect the HDMI OUT (TV eARC/ARC) terminal on the back of the product to the HDMI IN (ARC) terminal on the TV.

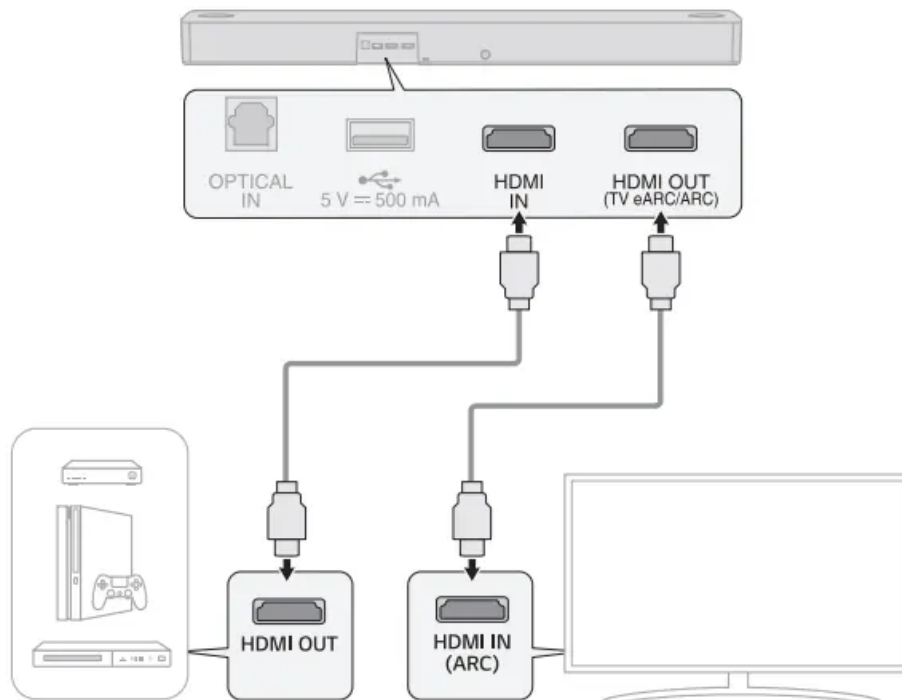

3. Press the Function  button repeatedly until "HDMI" appears on the status display.

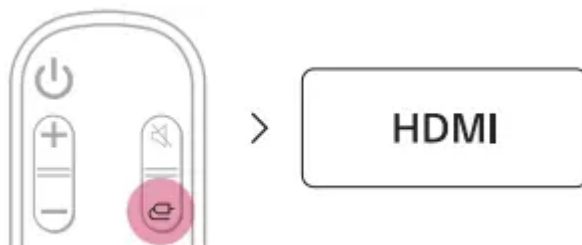

4. When the external device is properly connected to the product, you can listen to the sound of the device. When playing the video with Dolby Atmos® or DTS:X® technology, either "DOLBY ATMOS" or "DTS:X" will appear on the status display

## Connecting with an Optical Cable

You can connect a TV or external device to the product with an optical cable for a deep, magnificent sound.

### Connecting an external device via optical cable

1. Use the optical cable to connect the OPTICAL IN terminal on the back of the product to the OPTICAL OUT terminal of your external device (ex. TV, Blu-ray player) as shown in the picture.

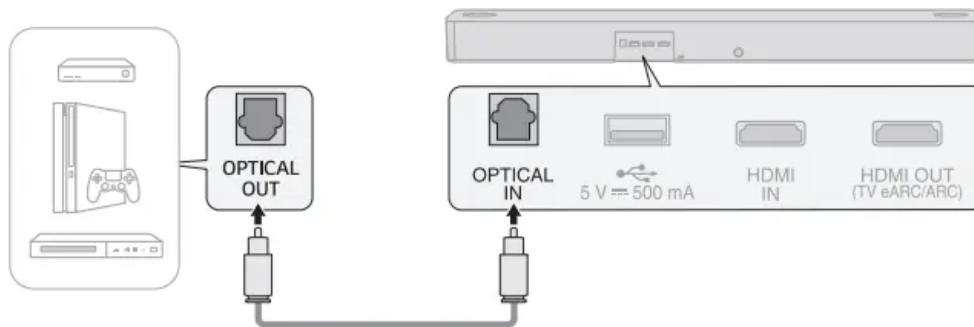

2. Press the Function  button repeatedly until “OPT/HDMI ARC” appears on the status display.



3. When the external device is properly connected to the product, “OPT” will appear on the status display

## Using the Product as an Audio System

### Connecting via Bluetooth

You can play music files stored on a Bluetooth device, or run music apps to enjoy the music with this product.

Please check the following first.

- Bluetooth devices to be connected to the product should meet the following specifications.
  - Version: 4.0 or higher

◦ Codec: SBC, AAC



- Steps to connect the device to the product may vary depending on the Bluetooth device type and model. For more information on how to connect the device, please refer to your external device's user manual.

Select the [Bluetooth] from your smartphone's Settings menu.

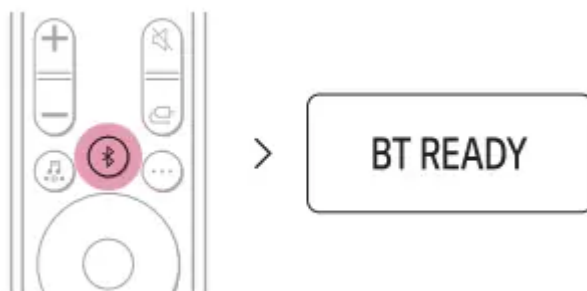

Settings menu items may vary depending on your smartphone manufacturer and model.

1. Turn on the product.
2. Press the Bluetooth pair  button. After a moment, "BT READY" appears on the status display.

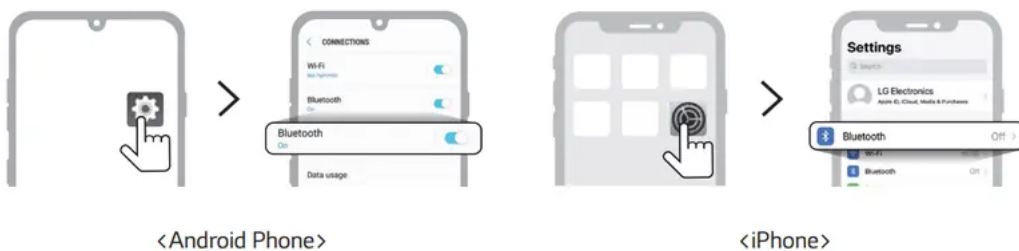

3. Tap the Settings ( / ) button on your smartphone and select  Bluetooth.



4. Turn on the Bluetooth function. ( Off >  On)

5. You will see a list of connectable devices on your smartphone. Find and tap "LG SPD7Y (XX)".

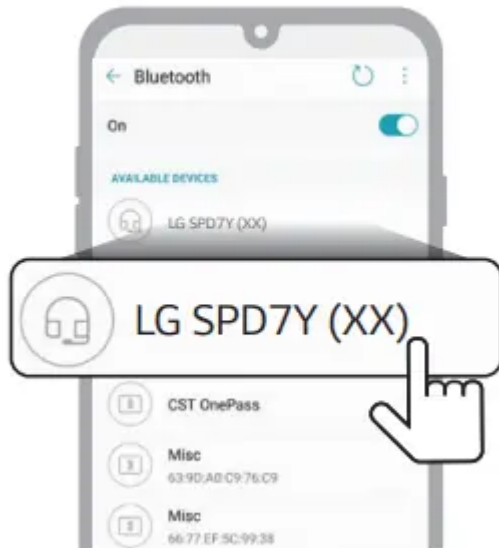

6. When the product is connected to the smartphone via Bluetooth, you will see the status display change from “PAIRED” → “Connected Bluetooth device name” → “BT”.



7. If you cannot find the product “LG SPD7Y (XX)”, tap the Refresh  button at the top right of the screen on the Android smartphone or turn the Bluetooth off and turn it on again on iPhone.

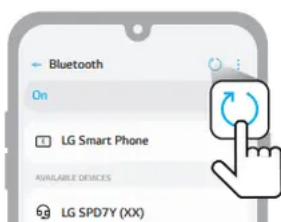

<Android Phone>

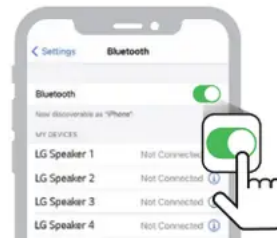

<iPhone>

8. Run a Music app and listen to music on the smartphone.









## **Before Reporting Product Malfunction**

### **Troubleshooting**

If you experience the following issues while using the product, please perform several checks, as they may not be malfunctions.

### **General Errors**

Issue	Solution
<p><b>The product does not work properly</b></p>	<ul style="list-style-type: none"> <li>• Unplug the power cables and any external devices such as your TV, subwoofer, or amplifier from the product, then plug them in again.</li> <li>• Please beware that previous product settings may be lost.</li> </ul>
<p><b>The power does not turn on</b></p>	<ul style="list-style-type: none"> <li>• Is the power cord plugged into the outlet properly? <ul style="list-style-type: none"> <li>◦ Connect the power plug to the outlet correctly.</li> </ul> </li> </ul>
<p><b>There is no sound</b></p>	<ul style="list-style-type: none"> <li>• Is the volume set to minimum? <ul style="list-style-type: none"> <li>◦ Press the <b>Volume</b>   button on the remote control to turn up the volume.</li> <li>◦ If you are using an external device such as a set-top box, portable device, or <b>Bluetooth</b> device, adjust the volume of the external device.</li> </ul> </li> <li>• Is the mute function activated? <ul style="list-style-type: none"> <li>◦ If <b>"MUTE"</b> appears on the status display, the mute function is on. Press the <b>Mute</b>  button to unmute.</li> </ul> </li> <li>• Is the correct product function selected according to the external device connected? <ul style="list-style-type: none"> <li>◦ Press the <b>Function</b>  button to check if you selected the correct function.</li> </ul> </li> </ul>
<p><b>The subwoofer does not produce sound</b></p>	<ul style="list-style-type: none"> <li>• Is the product properly connected to the wireless subwoofer? <ul style="list-style-type: none"> <li>◦ If the LED on the back of the wireless subwoofer is blinking green or lit in red, it means it is not connected. If the connection is established, a</li> </ul> </li> </ul>

	<p>green light will appear. Reconnect the product to the wireless subwoofer. (→ See "Connecting the Product" on.)</p>
<b>The remote control does not work properly</b>	<ul style="list-style-type: none"> <li>• When using the remote control, point it at the front of the product.</li> <li>• Use the remote control within a 7-m (23 ft) radius of the product.</li> <li>• Replace the batteries with new ones as needed.</li> </ul>
<b>The Auto Power function does not work</b>	<ul style="list-style-type: none"> <li>• Check connection to external devices (ex. set-top box, portable device, <b>Bluetooth</b> device).</li> </ul>
<b>LG Sound Sync does not work</b>	<ul style="list-style-type: none"> <li>• Check whether your TV supports LG Sound Sync.</li> <li>• Check if the TV is properly connected to the product via an optical cable. <ul style="list-style-type: none"> <li>◦ Press the <b>Settings</b> button on the TV remote control to check if the function is turned on in [LG Sound Sync].</li> </ul> </li> </ul>
<b>The product volume is low</b>	<ul style="list-style-type: none"> <li>• Check the following and change the settings accordingly. <ul style="list-style-type: none"> <li>◦ When the product is connected to a TV, press the <b>Settings</b> button on the TV remote control, select the [Speaker] menu, and change the [Digital Sound Output] setting from [PCM] to [AUTO] or [BITSTREAM].</li> <li>◦ If the product is connected to a playback device such as a DVD player or Blu-ray disc player, go to the connected device's Settings menu. Change the [Digital Sound Output] setting from [PCM] to [PRIMARY PASS-THROUGH] or [BITSTREAM]. Set the [DRC] of the connected device to [OFF].</li> <li>◦ If the product's Night Time mode is on, turn it off by pressing the</li> </ul> </li> </ul>





	<p><b>Settings</b> button and <b>Left/Right</b> and then <b>Up/Down</b>.</p>
<p><b>The product fails to recognize a USB storage device</b></p>	<ul style="list-style-type: none"> <li>• The product may not support the file format of the USB storage device. Format the USB storage device and reconnect it. When formatting, refer to the USB storage device formats supported by the product and select an appropriate file format. (→ See "Connecting to a USB Storage Device" on .)</li> </ul>
<p><b>A Bluetooth device cannot be paired</b></p>	<ul style="list-style-type: none"> <li>• Press the Settings button on the <b>Bluetooth</b> device and check whether the <b>Bluetooth</b> function is enabled. If <b>Bluetooth</b> is enabled, turn it off and on, then try again.</li> <li>• Remove any obstacles between the product and the <b>Bluetooth</b> device.</li> <li>• <b>Bluetooth</b> pairing (connection) may not work properly depending on the <b>Bluetooth</b> device type or the surrounding environment.</li> </ul>

## Problems in Wireless Connection

Issue	Solution
<p><b>There is radio interference</b></p>	<ul style="list-style-type: none"> <li>• Install the product and the wireless subwoofer as close to each other as possible.</li> <li>• Do not install the product on metal furniture.</li> <li>• Wireless communication may not work properly in weak signal areas.</li> </ul>
<p><b>The Bluetooth connection is causing a malfunction or making noise</b></p>	<ul style="list-style-type: none"> <li>• Do you hear noise or experience malfunctions when using Bluetooth? <ul style="list-style-type: none"> <li>◦ Do not let any part of your body contact the transceiver of the Bluetooth device or the product.</li> <li>◦ Do not install the Bluetooth device on a wall or in a secluded spot.</li> <li>◦ Remove any obstacles between the product and the Bluetooth device.</li> <li>◦ Install the Bluetooth device near the product.</li> </ul> </li> <li>• When the Bluetooth device is too far from the product, Bluetooth may be disconnected or malfunctions may occur. <ul style="list-style-type: none"> <li>◦ Install the Bluetooth device 1 m away from devices that use the same frequency as the product, such as wireless routers, medical equipment, and microwave ovens.</li> </ul> </li> </ul>

### Turning off the Demo Mode



Issue	Solution
<p><b>The remote control does not work</b></p>	<ul style="list-style-type: none"> <li>• Does the text on the status display remain unchanged, even if you press the Function  button several times?</li> <li>• Do you only see the text “DEMO” in the status display? <ul style="list-style-type: none"> <li>◦ The demo mode may be activated on the product. Unplug the product's power cable and plug it back in.</li> <li>◦ If the remote control still does not work, press the Volume   button on the product to set the volume level at 2, the press and hold the Function  button for about 5 seconds. If the currently selected function appears on the status display, it means that demo mode has been turned off</li> </ul> </li> </ul>

**Warning**

This content is compiled from multiple sources and is provided for reference purposes only. It may not be complete or fully applicable to all situations. If you are unable to resolve your issue, please contact the product manufacturer or an authorized service provider for official support.

