

General description

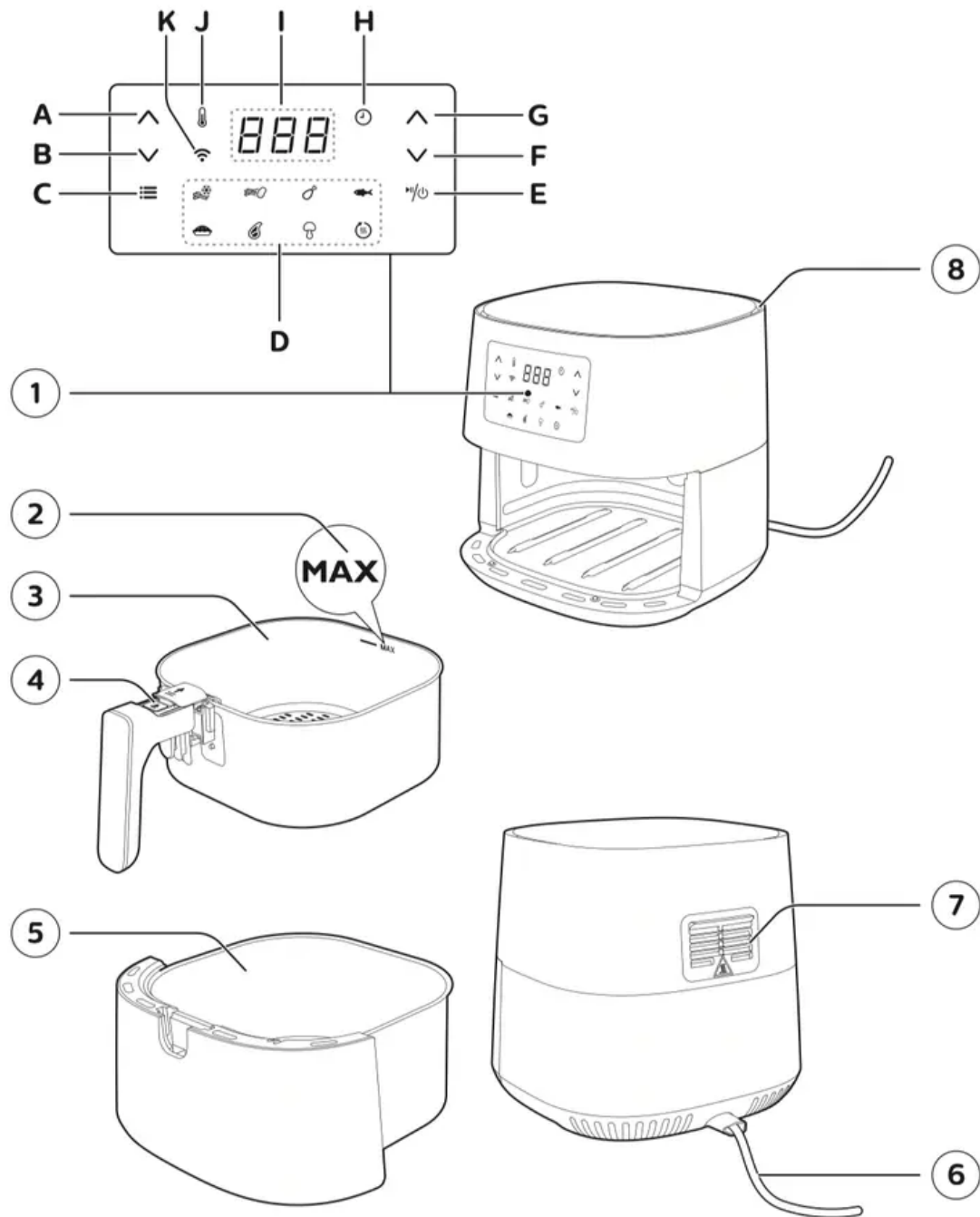

1. Control panel

A Temperature up button

B Temperature down button

C Menu button

D Preset menus

- E On/Off button
- F Time down button
- G Time up button
- H Time indicator
- I Screen
- J Temperature indicator
- K Wi-Fi indicator

2. MAX indication

3. Basket

4. Basket release button





5. Pan

6. Power cord

7. Air outlets

8. Air inlet

WiFi Indicator Status

<p>The Wi-Fi indicator  is off</p>	<ul style="list-style-type: none"> • Either your Airfryer is not connected to your home WiFi (no initial WiFi set-up done so far), or the connection to your home WiFi is lost due to e.g. home router has changed or the distance between the Airfryer and router is too far
<p>The Wi-Fi indicator  is on</p>	<ul style="list-style-type: none"> • Configuration with the NutriU App is complete and the Airfryer is connected to the Home WiFi
<p>The Wi-Fi indicator  is blinking</p>	<ul style="list-style-type: none"> • Either the Airfryer is in the "set-up" mode during the WiFi set-up process. The screen shows three dashes and the buttons on the Airfryer are inactive; or if it was already connected, the blinking LED is an indication that the Airfryer is in the process of connecting to the home WiFi.
<p>The Wi-Fi indicator  is blinking with long break in between</p>	<ul style="list-style-type: none"> • The WiFi functionality of the Airfryer has defect. You can either use the Airfryer without the connectivity features, or you can call the Philips service hot line or contact the Consumer Care Center in your country.



Before first use

1. Remove all packing material.
2. Remove any stickers or labels (if available) from the appliance.
3. Thoroughly clean the appliance before first use, as indicated in the cleaning chapter.

The NutriU App

Your Philips Airfryer is WiFi enabled and allows you to connect with the NutriApp to gain the full Airfryer experience. Within the App you can select your favorite recipes, send it to the Airfryer and start it from your smart device. You can start, monitor and adjust the cooking process on your smart device from wherever you are, even if you are not at home.

Connecting your Airfryer to the App

1. Put the plug of the Airfryer in the wall outlet.
2. Make sure that your smart device is within reach of your home WiFi network before you start the easy WiFi set-up process.
3. Download the Philips NutriU App on your smart device from the App store or from www.philips.com/nutriu, follow the registration process and select the connected Airfryer in your profile under "My Appliances".
4. Follow the instructions in the App to connect your Airfryer to your WiFi and to pair your Airfryer.
5. When the WiFi LED on the user interface of the Airfryer is solid on, the Airfryer is connected.

Note

- Make sure to connect your Airfryer to a 2.4 GHz 802.11 b/g/n home WiFi network.
- The easy WiFi set-up is needed to connect the Airfryer to your home WiFi.
- The pairing process is to connect the NutriU App with your smart Airfryer.
- The WiFi setup process can be cancelled via the App or by unplugging the Airfryer.
- You can pair only one smart device at the same time to your Airfryer. If a second user starts the pairing process, the first user is kicked out and has to pair again the next time when cooking with the Airfryer.
- To start the pairing process, long press the temperature down button and follow the instructions in the App, or start it from the settings in the NutriU App.

Preparing for use

1. Place the appliance on a stable, horizontal, level and heat-resistant surface.

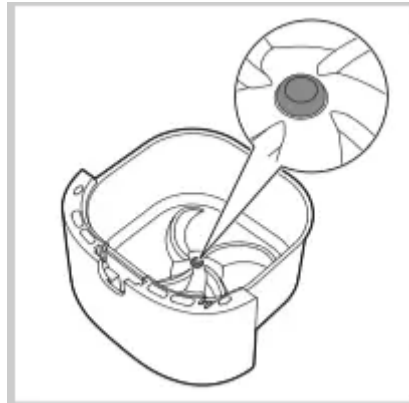

Note

- Do not put anything on top or on the sides of the appliance. This could disrupt the airflow and affect the frying result.
- Do not place the operating appliance near or underneath objects that could be damaged by steam, such as walls and cupboard.
- Leave the rubber plug in the pan. Do not remove it before cooking.

Using the appliance

Food table

The table below helps you select the basic settings for the types of food you want to prepare.

Note

- Keep in mind that these settings are suggestions. As ingredients differ in origin, size, shape as well as brand, we cannot guarantee the best setting for your ingredients.
- When preparing larger amount of food (e.g. fries, prawns, drumsticks, frozen snacks), shake, turn, or stir the ingredients in the basket 2 to 3 times in order to achieve a consistent result.

Ingredients	Min.– max. amount	Time (min)	Temperature	Note
Thin frozen fries (7x7 mm/0.3x0.3 in)	200–800 g / 7–28 oz	14–31	180°C/350°F	• Shake, turn or stir 2–3 times in between
Homemade fries (10x10 mm/0.4x0.4 in thick)	200–800 g / 7–28 oz	20–40	180°C/350°F	• Shake, turn or stir 2–3 times in between

Ingredients	Min.– max. amount	Time (min)	Temperature	Note
Frozen chicken nuggets	200–600 g/ 7–21 oz	9–20	200°C/400°F	· Shake, turn or stir halfway
Frozen spring rolls	200–600 g/ 7–21 oz	9–20	200°C/400°F	· Shake, turn or stir halfway
Hamburger (around 150 g/5 oz)	1–5 patties	16–21	200°C/400°F	
Meat loaf	1200 g / 42 oz	55–60	150°C/300°F	· Use the baking accessory
Meat chops without bone (around 150 g/5 oz)	1–4 chops	15–20	200°C/400°F	· Shake, turn or stir halfway
Thin sausages (around 50 g/1.8 oz)	2–10 pieces	11–15	200°C/400°F	· Shake, turn or stir halfway
Chicken drumsticks (around 125 g/4.5 oz)	2–8 pieces	17–27	180°C/350°F	· Shake, turn or stir halfway
Chicken breast (around 160 g/6 oz)	1–5 pieces	15–25	180°C/350°F	
Whole chicken	1200 g/42 oz	60–70	180°C/350°F	
Whole fish (around 300–400 g/11–14 oz)	1–2 fish	20–25	200°C/400°F	
Fish filet (around 200 g/7 oz)	1–5 (1 layer)	25–32	160°C / 325°F	
Mixed vegetables (roughly chopped)	200–800 g/7–28 oz	9–18	180°C/350°F	· Set the cooking time according to your own taste · Shake, turn or stir halfway
Muffins (around 50 g/1.8 oz)	1–9	13–15	180°C/350°F	· Use the Muffin cups
Cake	500 g/18 oz	40–45	160°C/325°F	· Use a cake pan
Pre-baked bread/rolls (around 60 g/ 2 oz)	1–6 pieces	6–8	200°C/400°F	
Homemade bread	800 g / 28 oz	55–65	150°C/300°F	· Use the baking accessory · The shape should be as flat as possible to avoid that the bread touches the heating element when rising.

Airfrying

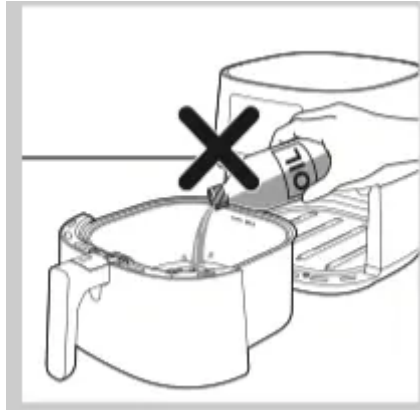

Caution

- This is an Airfryer that works on hot air. Do not fill the pan with oil, frying fat or any other liquid.
- Do not touch hot surfaces. Use handles or knobs. Handle the hot pan with oven-safe gloves.
- This appliance is for household use only.
- This appliance may produce some smoke when you use it for the first time. This is normal.
- Preheating of the appliance is not necessary.



1. Put the plug in the wall outlet.

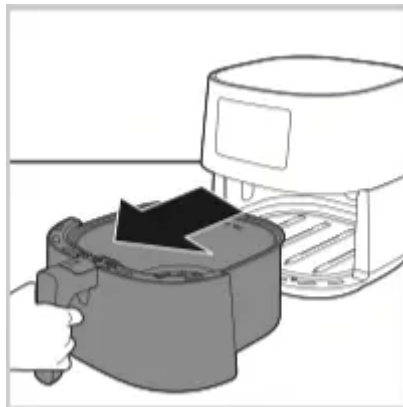

2. Remove the pan with the basket from the appliance by pulling the handle.



3. Put the ingredients in the basket.

Note

- The Airfryer can prepare a large range of ingredients. Consult the 'Food table' for the right quantities and approximate cooking times.
- Do not exceed the amount indicated in the 'Food table' section or overfill the basket beyond the 'MAX' indication as this could affect the quality of the end result.
- If you want to prepare different ingredients at the same time, make sure you check the suggested cooking time required for the different ingredients before you start to cook them simultaneously.



4. Put the pan with the basket back into the Airfryer.

Caution

- Never use the pan without the basket in it.
- Do not touch the pan or the basket during and for some time after use, as they get very hot.

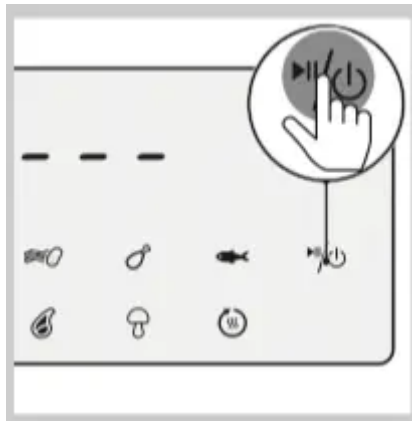

5. Press the power On/Off button to switch on the appliance.

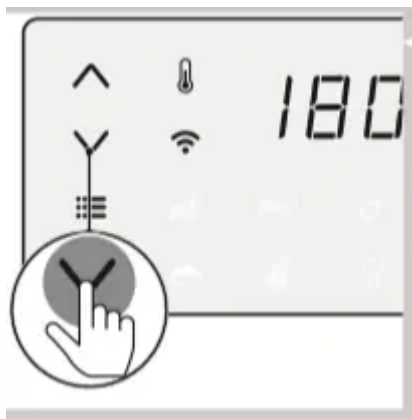

6. Press the temperature up or down button to choose the needed temperature.

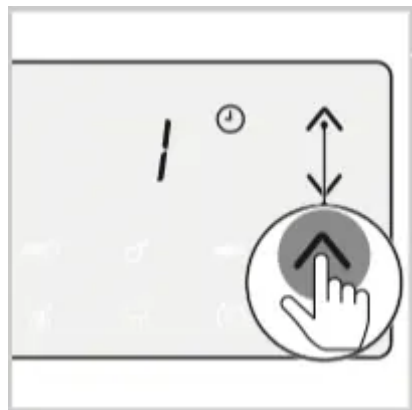

7. Press the time up button to choose the needed time.



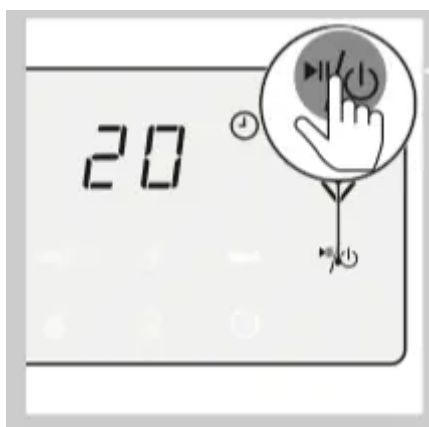

8. Press the On/Off button to start the cooking process.

Note

- During cooking the temperature and time are shown alternately.
- The last cooking minute counts down in seconds.
- Refer to the food table with basic cooking settings for different types of food.
- When the cooking process is started and your Airfryer is paired with your smart device, you can see, control and change the cooking parameters also in the NutriU App.
- To change the temperature unit from Celsius to Fahrenheit or the other way around on your Airfryer, press the temperature up and down button at the same time for about 10 seconds.

Tip

- During cooking, if you want to change the cooking time or temperature, press the corresponding up or down button at any time to do so.
- To pause the cooking process, press the On/Off button. To resume the cooking process, press the On/Off button again to continue the cooking process.
- The device is automatically in pause mode when you pull out the pan and the basket. The cooking process continues when the pan and the basket are put in the appliance again.



Note

- If you do not set the required cooking time within 30 minutes, the appliance automatically shuts off for safety reasons.
- Some ingredients require shaking or turning halfway through the cooking time (see 'Food table'). To shake the ingredients, pull out the pan with the basket, place it on a heat resistant work top, slide the lid and press the basket release button to remove the basket and shake the basket over the sink. Then put the basket into the pan, and slide them back into the appliance.
- If you set the timer to the half of the cooking time and you hear the timer bell it is time to shake or turn the ingredients. Be sure to reset the timer to the remaining cooking time.

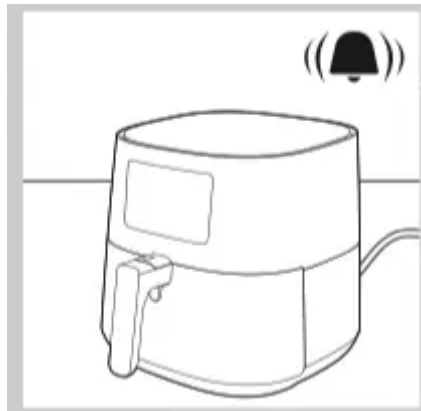

9. When you hear the timer bell, the cooking time has elapsed.

Note

- You can stop the cooking process manually. To do this, press the On/Off button.

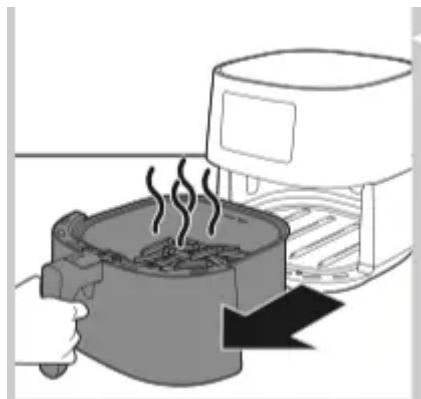

10. Pull out the pan and check if the ingredients are ready.

Caution

- The Airfryer pan is hot after the cooking process. Always place it on a heat resistant work top (eg. trivet, etc.) when you remove the pan from the device.

Note

- If the ingredients are not ready yet, simply slide the pan back into the Airfryer by the handle and add a few extra minutes to the set time.





11. To remove small ingredients (e.g. fries), lift the basket out of the pan by sliding the lid first, and then pressing the basket release button.

Caution

- After the cooking process, the pan, the basket, the interior housing and the ingredients are hot. Depending on the type of ingredients in the Airfryer, steam may escape from the pan.

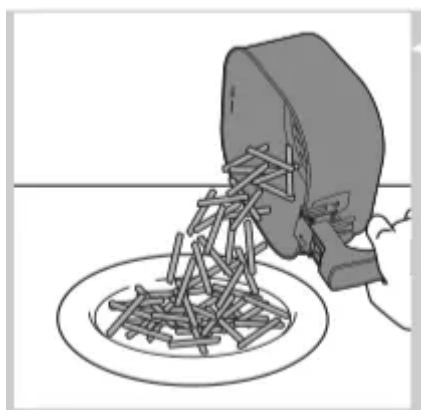

12. Empty the basket contents into a bowl or onto a plate. Always remove the basket from the pan to empty contents as hot oil may be in the bottom of the pan.

Note

- To remove large or fragile ingredients, use a pair of tongs to lift out the ingredients.
- Excess oil or rendered fat from the ingredients is collected on the bottom of the pan.
- Depending on the type of ingredients cooking, you may want to carefully pour off any excess oil or rendered fat from the pan after each batch or before shaking or replacing the basket in the pan. Place the basket on a heat-resistant surface. Wear oven-safe gloves to pour off excess oil or rendered fat. Return the basket into the pan.

When a batch of ingredients is ready, the Airfryer is instantly ready for preparing another batch.

Note

- Repeat steps 3 to 12 if you want to prepare another batch.

Choosing the keep warm mode

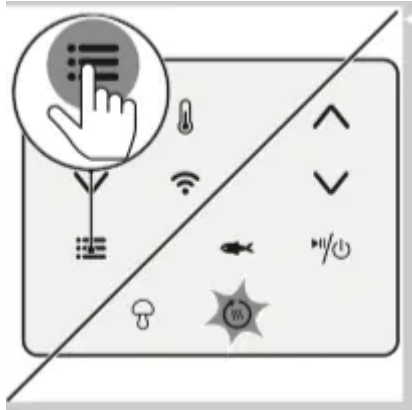

1. Press the menu button as often as the keep warm icon is blinking.

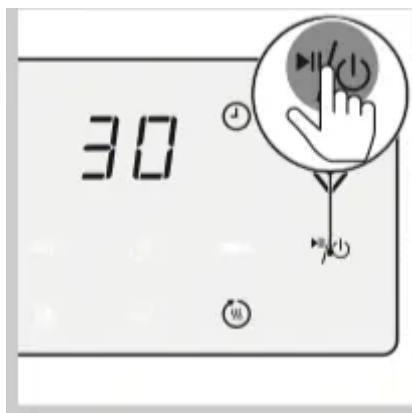

2. Press the On/Off button to start the keep warm mode.

Note

- The keep warm timer is set to 30 minutes. To change the keep warm time (1 - 30 minutes), press the time down button. The time will be confirmed automatically.
- The temperature cannot be changed in keep warm mode.

3. To pause the keep warm mode, press the On/Off button. To resume the keep warm mode, press the On/Off button again.

4. To exit the keep warm mode, long press the On/Off button.

Tip

- If food like French fries loses too much crispness during the keep warm mode, either shorten the keep warm time by switching off the appliance earlier or crisp them up for 2-3 minutes at the temperature of 180°C/350°F.

Note

- During the keep warm mode, the fan and heater inside of the appliance turn on from time to time.

- The keep warm mode is designed to keep your food warm immediately after it is cooked in the Airfryer. It is not meant for reheating.

Cooking with a preset

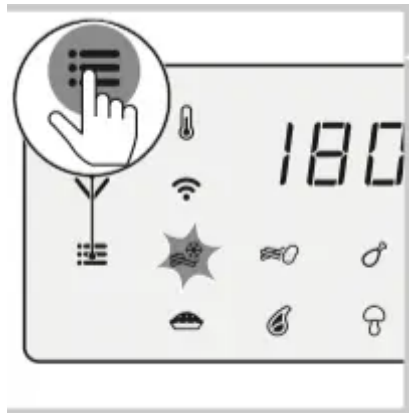

1. Follow steps 1 to 5 in chapter "Airfrying".
2. Press the Menu button. The frozen snacks icon is blinking. Press the Menu button as often as your needed preset is blinking.

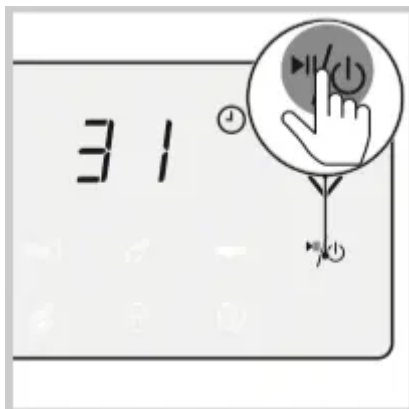

3. Start the cooking process by pressing the On/Off button.

Note

- In the following table you can find more information about the presets.

Preset	Preset time (min)	Preset temperature	Weight (Max.)	Information
 Frozen potato based snacks	31	180°C/ 350°F	800 g/28 oz	<ul style="list-style-type: none"> • Potato based frozen snacks like frozen French fries, potato wedges, criss-cross fries etc. • Shake, turn or stir 2-3 times in between

Preset	Preset time (min)	Preset temperature	Weight (Max.)	Information
 Fresh fries	38	180°C/ 350°F	800 g/28 oz	<ul style="list-style-type: none"> Use mealy potatoes 10x10mm / 0.4x0.4 in thick cut Soak 30 minutes in water, dry then add ¼ to 1 tbsp of oil Shake, turn or stir 2-3 times in between
 Chicken drumsticks	27	180°C/ 350°F	1000 g/35 oz	<ul style="list-style-type: none"> Up to 8 chicken drumsticks Shake, turn or stir in between
 Whole fish around 300 g/11 oz	20	200°C/ 400°F	600 g/21 oz	
 Cake	45	160°C/ 325°F	500 g/18 oz	<ul style="list-style-type: none"> Use the XL baking accessory (199 x 189 x 80 mm)
 Meat chops	20	200°C/ 400°F	600 g/21 oz	<ul style="list-style-type: none"> Up to 4 meat chops without bone
 Mixed vegetables	18	180°C/ 350°F	800 g/28 oz	<ul style="list-style-type: none"> Roughly chopped Use the XL baking accessory
 Keep warm	30	80°C/ 175°F	N/A	<ul style="list-style-type: none"> Temperature cannot be adjusted

Changing to another preset

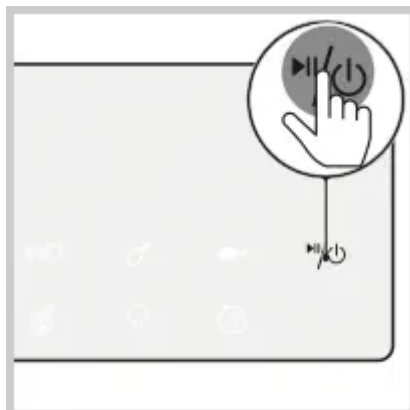

1. During the cooking process long press the power On/Off button to stop the cooking process. The device is then in stand-by mode.

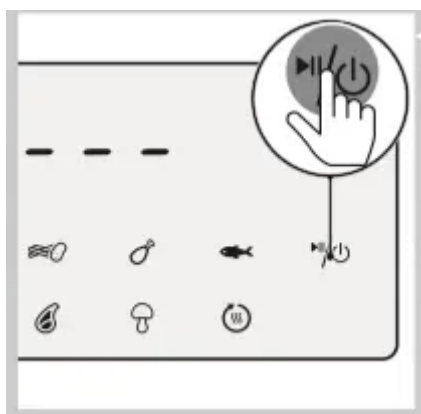

2. Press the On/Off button again to turn on the device.

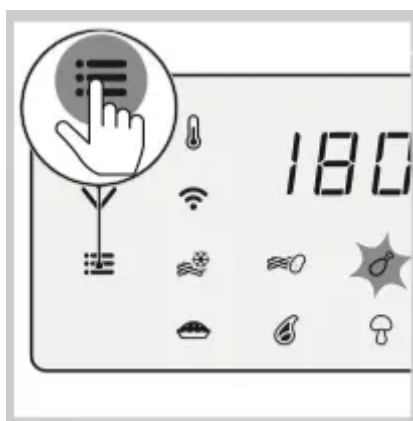

3. Press the menu button as often as your needed preset is blinking.

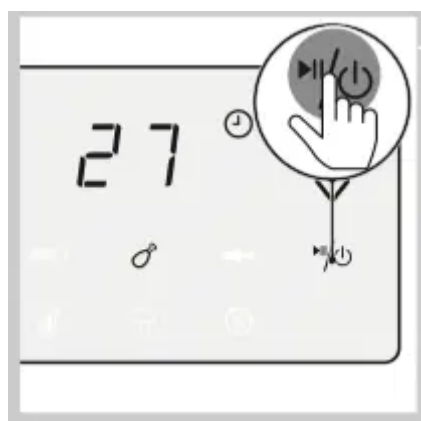

4. Press the On/Off button to start the cooking process.

Starting a recipe from the NutriU App

1. Press the On/Off button to turn on the Airfryer.
2. Open the NutriU App on your smart device and look for your preferred recipe.
3. Open the recipe and start the cooking process in the App.

Note

- Make sure that when cooking recipes that are developed for your Airfryer, use the same amount of food mentioned in the recipes. When using different ingredients or a different amount of food items, adjust the cooking time. When cooking recipes that are not developed for your Airfryer, be aware the time and temperature might be adjusted.

Tip

- Via the filter in the recipe search you can filter your smart Airfryer to get the recipes that are developed for your device.
- When the cooking process is started from the App, you can see the cooking settings also on the screen of the Airfryer.
- You can pause the cooking process or change the settings on the Airfryer or in the App.
- When the cooking process is over you can start the keep warm mode in the App or start it from the "keep warm" preset on the Airfryer.
- If the food is not done yet, you can also prolong the cooking process within the App or on the Airfryer.
- To exit the cooking process before the cooking time is over, long press the On/ Off button on the Airfryer or press the pause and then the stop icon in the App.
- You can also start your individual time and temperature in the NutriU App.
- On the bottom of the Home Screen there is the button to go to the home screen, the recipes, manual mode, articles or your profile. Press the manual mode button and send your individual time and temperature to the Airfryer.

Making home-made fries

To make great home-made fries in the Airfryer:

- Choose a potato variety suitable for making fries, e.g. fresh, (slightly) floury potatoes.
 - It is best to air fry the fries in portions of up to 800 g/28 oz for an even result. Larger fries tend to be less crispy than smaller fries.
1. Peel the potatoes and cut into sticks (10 x 10 mm/0.4 x 0.4 in thick).
 2. Soak the potato sticks in a bowl of water for at least 30 minutes.
 3. Empty the bowl and dry the potato sticks with a dish towel or paper towel.
 4. Pour one tablespoon of cooking oil into the bowl, put the sticks in the bowl and mix until the sticks are coated with oil.
 5. Remove the sticks from the bowl with your fingers or a slotted kitchen utensil so excess oil remains in the bowl.

Note

- Do not tilt the bowl to pour all the sticks in the basket at once to prevent excess oil from going into the pan.
6. Put the sticks into the basket.
 7. Fry the potato sticks and shake the basket 2-3 times during cooking.

Cleaning

Warning

- Let the basket, the pan, and the inside of the appliance cool down completely before you start cleaning.
 - The pan, the basket, and the inside of the appliance have a non-stick coating. Do not use metal kitchen utensils or abrasive cleaning materials as this may damage the non-stick coating.
1. Press the power On/Off button to switch off the appliance, remove the plug from the wall outlet and let the appliance cool down.

Tip

- Remove the pan and the basket to let the Airfryer cool down more quickly.
2. Dispose of rendered fat or oil from the bottom of the pan.
 3. Clean the pan and the basket in a dishwasher. You can also clean them with hot water, dishwashing liquid and a non-abrasive sponge (see 'Cleaning table').

Note

- Put the pan with the rubber plug in the dishwasher. Do not remove the rubber plug before cleaning.

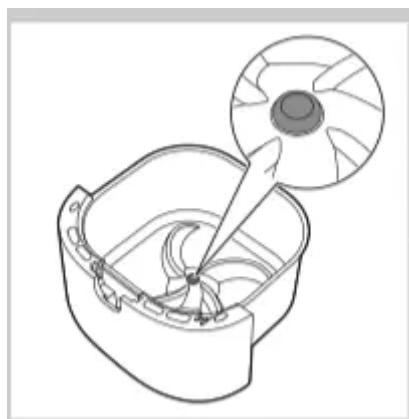

Tip

- If food residues stuck to the pan or the basket, you can soak them in hot water and dishwashing liquid for 10–15 minutes. Soaking loosens the food residues and makes it easier to remove. Make sure you use a dishwashing liquid that can dissolve oil and grease.

If there are grease stains on the pan or the basket and you have not been able to remove them with hot water and dishwashing liquid, use a liquid degreaser.

- If necessary, food residues stuck to the heating element can be removed with a soft to medium bristle brush. Do not use a steel wire brush or a hard bristle brush, as this might damage the coating on the heating element.

4. Wipe the outside of the appliance with a moist cloth.

Note

- Make sure no moisture remains on the control panel. Dry the control panel with a cloth after you have cleaned it.





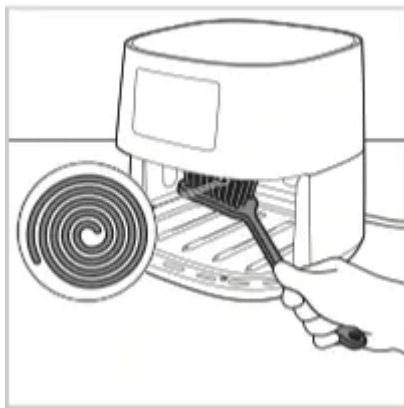

5. Clean the heating element with a cleaning brush to remove any food residues.



6. Clean the inside of the appliance with hot water and a non-abrasive sponge.

Cleaning table

			
	✓	✓	✗
	✓	✓	✗

Storage

1. Unplug the appliance and let it cool down.
2. Make sure all parts are clean and dry before storing.

Note

- Always hold the Airfryer horizontally when you carry it. Make sure that you also hold the pan on the front part of the appliance as the pan with the basket can slide out of the appliance if accidentally tilted downwards. This can lead to damaging of these parts.
- Always make sure that the removable parts of the Airfryer are fixed before you carry and/or store it.

Factory reset

For a factory reset of the Airfryer, press the temperature and time up buttons at the same time for 10 seconds.

Your Airfryer is then no more connected to your home WiFi and not paired with your smart device anymore.

Troubleshooting

This chapter summarizes the most common problems you could encounter with the appliance. If you are unable to solve the problem with the information below, visit [philips/support](https://www.philips.com/support) for a list of frequently asked questions or contact the Consumer Care Center in your country.

Problem	Possible cause	Solution
The outside of the appliance becomes hot during use.	The heat inside radiates to the outside walls.	This is normal. All handles and knobs that you need to touch during use stay cool enough to touch.
		The pan, the basket, and the inside of the appliance always become hot when the appliance is switched on to ensure the food is properly cooked. These parts are always too hot to touch
		If you leave the appliance switched on for a longer time, some areas get too hot to touch. These areas are marked on the appliance with the following icon:  As long as you are aware of the hot areas and avoid touching them, the appliance is completely safe to use.
My home-made fries do not turn out as I expected.	You did not use the right potato type.	To get the best results, use fresh floury potatoes. If you need to store the potatoes, do not store them in a cold environment like in a fridge. Choose potatoes whose package states that they are suitable for frying.
	The amount of ingredients in the basket is too big.	Follow the instructions on page 19 in this user manual to prepare home-made fries.
	Certain types of ingredients need to be shaken halfway through the cooking time.	Follow the instructions on page 19 in this user manual to prepare home-made fries.
The Airfryer does not switch on.	The appliance is not plugged in.	Check if the plug is inserted in the wall outlet properly.
	Several appliances are connected to one outlet.	The Airfryer has a high wattage. Try a different outlet and check the fuses.

<p>I see some peeling off spots inside my Airfryer.</p>	<p>Some small spots can appear inside the pan of the Airfryer due to the incidental touching or scratching of the coating (e.g. during cleaning with harsh cleaning tools and/or while inserting the basket).</p>	<p>You can prevent damage by lowering the basket into the pan properly. If you insert the basket at an angle, its side may knock against the wall of the pan, causing small pieces of coating to chip off. If this occurs, please be informed that this is not harmful as all materials used are food-safe.</p>
<p>White smoke comes out of the appliance.</p>	<p>You are cooking fatty ingredients.</p>	<p>Carefully pour off any excess oil or fat from the pan and then continue cooking.</p>
	<p>The pan still contains greasy residues from previous use.</p>	<p>White smoke is caused by greasy residues heating up in the pan. Always clean the pan and the basket thoroughly after every use.</p>
	<p>Breading or coating did not adhere properly to the food.</p>	<p>Tiny pieces of airborne breading can cause white smoke. Firmly press breading or coating to food to ensure it sticks.</p>
	<p>Marinade, liquid or meat juices are splattering in the rendered fat or grease.</p>	<p>Pat food dry before placing it in the basket.</p>
<p>The WiFi LED on my Airfryer is not shining anymore.</p>	<ul style="list-style-type: none"> • The Airfryer is not connected to your home WiFi anymore. • You have changed your home WiFi network. 	<p>Start the WiFi set up process by long pressing the menu button and follow the instructions in the App.</p>
<p>The App shows that the pairing process is not successful.</p>	<p>Another user has paired the Airfryer with a different smart device and is currently cooking.</p>	<p>Wait until the other user has finished the current cooking process and re-pair your smart device with the Airfryer.</p>
<p>My display shows blinking "----".</p>	<p>Your Airfryer is updating the Firmware.</p>	<p>Wait for one minute, then the firmware update process is finished.</p>
<p>The screen on the Airfryer shows "E1".</p>	<p>The device is broken/defect.</p>	<p>Call the Philips service hot line or contact the Consumer Care Center in your country.</p>



Warning

This content is compiled from multiple sources and is provided for reference purposes only. It may not be complete or fully applicable to all situations. If you are unable to resolve your issue, please contact the product manufacturer or an authorized service provider for official support.

Document generated by [ManualsFile](#)