

USING THE RANGE

Surface Units

 **WARNING: FIRE HAZARD:** Never leave the range unattended with the cooktop ON above a Lo setting. Keep flammable items away from the cooktop. Turn off all controls when done cooking. Failure to follow these instructions can result in fire, serious injury or death.

Throughout this manual, features and appearance may vary from your model.

How to Set

- Push the knob in and turn in either direction to the setting you want.
- A surface ON indicator light will glow when any surface unit is on.

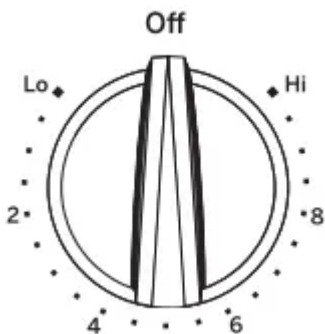

At both OFF and HI the control clicks into position. You may hear slight clicking sounds during cooking, indicating the control is maintaining your desired setting. Be sure you turn the control knob to OFF when you finish cooking.

Coil Cooktops

- Each coil surface unit uses "SENSI-TEMP TECHNOLOGY" to reduce the risk of cooktop oil and grease fires. This feature is located in the center of each surface unit. Power to the surface unit is temporarily interrupted when a pot or pan exceeds expected cooking temperatures. Even after the surface units are turned off, the surface unit retains enough heat to continue cooking. To avoid overcooking, remove pans from the surface units when the food is cooked. Avoid placing anything on the surface unit until it has cooled completely

Cookware for Coil Cooktops

The following information will help you choose cookware which will give good performance on coil cooktops.

NOTE: Follow all cookware manufacturer's recommendations when using any type of cookware on the coil cooktop.

More about Cookware

- Place only dry pans on the surface elements. Do not place lids on the surface elements, particularly wet lids. Wet pans and lids may stick to smooth surface when cool.
- Do not use woks that have support rings. This type of wok will not heat on the cooktop.
- We recommend that you use only a flat-bottomed wok. They are available at your local retail store. The bottom of the wok should have the same diameter as the surface element to ensure proper contact.
- Some special cooking procedures require specific cookware such as pressure cookers or deep-fat fryers. All cookware must have flat bottoms and be the correct size.

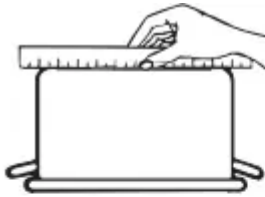

Check pans for flat bottoms by using a straight edge. You should not be able to pass a US nickel coin under the straight edge.



Do not use woks with support rings on the cooktop.



Use flat-bottomed woks on the cooktop.

Pans with rounded, curved, ridged or warped bottoms are not recommended.

Home Canning Tips

- Be sure the canner is centered over the surface unit.
- Make sure the canner is flat on the bottom.
- To prevent burns from steam or heat, use caution when canning.

- Use recipes and procedures from reputable sources. These are available from manufacturers such as Ball and Kerr and the Department of Agriculture Extension Service.
- Flat-bottomed canners are recommended. Use of water bath canners with rippled bottoms may extend the time required to bring the water to a boil.

Oven Controls

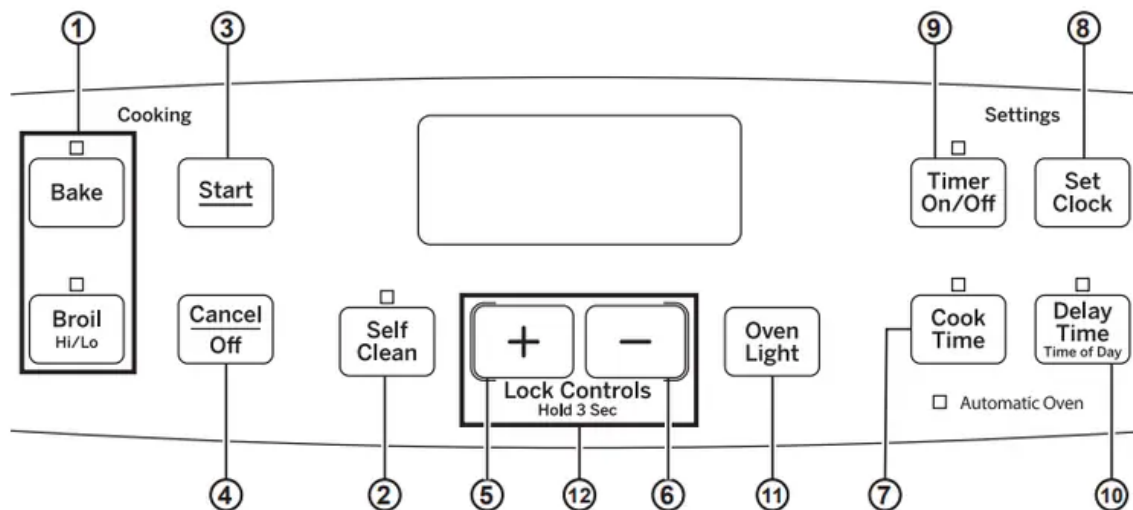

1. Traditional Cooking Modes: Your oven has the following traditional cooking modes: Bake and Broil Hi/Lo. See the Cooking Modes section for more information.
2. Self Clean: See the Cleaning the Oven section for important information about using this mode.
3. Start: Must be pressed to start any cooking, cleaning, or timed function.
4. Cancel/Off: Cancels ALL oven operations except the clock and timer.
5. + Pad: Short taps to this pad will increase the time or temperature by small amounts. Touch and hold the pad to increase the time or temperature by larger amounts.
6. - Pad: Short taps to this pad will decrease the time or temperature by small amounts. Touch and hold the pad to decrease the time or temperature by larger amounts.
7. Cook Time: Counts down cooking time and turns off the oven when the cooking time is complete. Press the Cook Time pad, use the +/- pads to program a cooking time in hours and minutes, then press Start. This can only be used with Bake.
8. Clock: Sets the oven clock time. Press the Set Clock pad and the +/- pads to program the clock. Press Start to save the time.
9. Timer: Works as a countdown timer. Press the Timer pad and the + - pads to program the time in hours and minutes. Press the Start pad. The timer countdown is complete. To turn the timer off press the Timer pad.

10. Delay Time: Delays when the oven will turn on.

Use this to set a time when you want the oven to start.

Press the Delay Time pad and use the +/- pads to program the time of day for the oven to turn on then press Start. Press the desired cooking mode and temperature then press Start. A cook time may also be programmed if desired. Follow the directions under Cook Time for setting this feature. This can only be used with Bake and Self-Clean.

NOTE: When using the delay time feature, foods that spoil easily—such as milk, eggs, fish, stuffings, poultry and pork—should not be allowed to sit for more than hour before or after cooking. Room temperature promotes the growth of harmful bacteria. Be sure that the oven light is off because heat from the bulb will speed harmful bacteria growth.

11. Oven Light: Turns the oven light on or off

12. Lock Controls: Locks out the control so that pressing the pads does not activate the controls. Press and hold the +/- pads for three seconds to lock or unlock the control. Cancel/Off is always active, even when the control is locked.

Special Features

There are several different special features on your range. To change the settings of these special features

- Press the Bake and Broil pads at the same time and hold for three seconds.
- "SF" will appear in the display
- Select the feature you want to change
- When the change has been made, press the Start key to save the change and return to the time of day.

Adjust the Oven Temperature

- This feature allows the oven baking temperature to be adjusted up to 35°F hotter or down to 35°F cooler. Use this feature if you believe your oven temperature is too hot or too cold and wish to change it. This adjustment affects Bake mode. No other cooking modes are affected.
- Press the Bake pad to enter the temperature adjustment mode. A number between 35 and - 35 will display. Use the +/- pads to set the desired temperature adjustment and use the Bake pad to change between negative and positive. Press the Start pad to save the temperature adjustment.

12-hour auto shut-off and Sabbath

- Options for this feature are "12 SHdn", "no SHdn" and "SAb"
- 12-hour auto shut-off turns off the oven after 12 hours of continuous operations.

- Sabbath mode disables the oven lights (the oven light will not turn on when the door is opened). all sounds (the control will not beep when a button is pressed). Broil. Cook Time. Timer. Clock. and Delay Time functions. Sabbath mode can only be used with Bake. This feature conforms to the Star-K Jewish Sabbath requirements.
- Press the Set Clock pad to view the current setting and then to change the setting.
- To use Sabbath mode. select "SAb" and press Start. A] will appear in the display and the clock will not display.
- Once in Sabbath mode. at any time you can press Bake to start the oven. Note that when programming a bake in Sabbath mode. the preset starting temperature will automatically be set to 350°F. Press the + or - pads to increase or decrease the temperature in 25°F increments for temperatures between 170°F and 550°F and then press Start.
- No sound will be given when the keys are pressed. At a random time between 30 seconds and 1 minute. Jf. will appear in the display indicating the oven is running.
- If you need to adjust the temperature while baking. press Bake again. Press the + or - pads to increase or decrease the temperature in 25°F from the previous temperature you set to the new baking temperature and then press Start.
- To turn the oven off. press Cancel/Off at any time. The oven will immediately turn off and J[will change to] indicating that the oven has turned off
- To exit Sabbath mode. make sure that the oven is turned off. Press and hold the Bake and Broil pads for 3 seconds to enter special features then press Delay Time until either "12 Shdn" or "no Shdhn" is in the display and press Start.

NOTE: If power outage occurs. the Sabbath mode will not resume when power is restored.

- If you wish to use the Cook Time feature to bake in the oven and then have the oven automatically turn off. you will need to press the Cook Time pad. enter a cooking time duration. and press Start. Then enter special features to start Sabbath mode as detailed above.

Oven Racks

- Recommended rack positions for various types of foods are provided in the Cooking Guide. Adjusting rack position is one way to impact cooking results. For example, if you would prefer darker tops on cakes, muffins, or cookies, try moving food one rack position higher. If you find foods are too brown on top try moving them down next time.
- When baking with multiple pans and on multiple racks, ensure there is at least 1½" between pans to allow sufficient space for air to flow.
- To avoid possible burns, place the racks in the desired position before you turn the oven on.

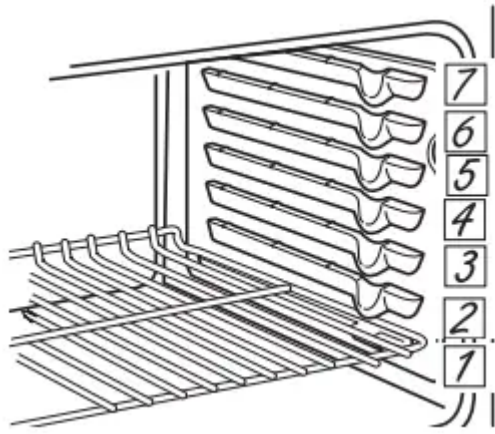

Cookware

Cookware Guidelines

- The material, finish, and size of cookware affect baking performance.
- Pans that absorb heat more readily can result in a browner, crisper, and thicker crust. If using dark and coated cookware check food earlier than minimum cook time. If undesirable results are obtained with this type of cookware consider reducing oven temperature by 25° F next time.
- Shiny pans can produce more evenly cooked baked goods such as cakes and cookies.
- Glass and ceramic pans heat slowly but retain heat well. These types of pans work well for dishes such as pies and custards.
- Air insulated pans heat slowly and can reduce bottom browning.
- Keep cookware clean to promote even heating.

Cooking Modes

Your new oven has a variety of cooking modes to help you get the best results. These modes are described below. Refer to the Cooking Guide section for recommendations for specific foods. Remember, your new oven may perform differently than the oven it is replacing.

Baking Modes

- When preparing baked goods such as cakes, cookies, and pastries always preheat the oven first. Follow recipe recommendations for food placement. If no guidelines are provided, center food in the oven.

Traditional Bake

- The traditional bake mode is intended for single rack cooking. This mode uses heat primarily from the lower element but also from the upper element to cook food. To use this mode press the Bake pad, use the +/- pads to set the desired temperature, and then press Start. Preheating is generally recommended when using this mode.

Cooking Guide

FOOD TYPE	RECOMMENDED MODE(S)	RECOMMENDED RACK POSITION(S)	ADDITIONAL SUGGESTIONS
Baked Goods			
Layer Cakes, sheet cakes, bundt cakes, muffins, quick breads on a Single Rack	Bake	4	Use shiny cookware.
Layer cakes* on Multiple Racks	Bake	3 and 5	Ensure adequate airflow (see illustration below).
Chiffon cakes (angel food)	Bake	1	Use shiny cookware.
Cookies, biscuits, scones on a Single Rack	Bake	4	Use shiny cookware.
Cookies, biscuits, scones on Multiple Racks	Bake	3 and 5	Ensure adequate airflow.
Beef & Pork			
Hamburgers	Broil Hi	6	Use a broil pan; move food down for more doneness/less searing. Watch food closely when broiling. For best performance center food below the broil heating element.
Steaks & Chops	Broil Hi	6	Use a broil pan; move food down for more doneness/less searing. Watch food closely when broiling. For best performance center food below the broil heating element.
Roasts	Bake	3 or 4	Use a low sided pan such as a broil pan. Preheating is not necessary.
Poultry			
Whole chicken	Bake	3 or 4	Use a low sided pan such as a broil pan.
Bone-in chicken breasts, legs, thighs	Broil Hi	2	If breaded or coated in sauce avoid Broil Hi modes. Broil skin side down first. Watch food closely when broiling. For best performance when broiling, center food below the broil heating element.
	Broil Lo Bake	2 or 3	
Boneless chicken breasts	Broil Lo Bake	2 or 3	If breaded or coated in sauce avoid Broil Hi modes. Broil skin side down first. Watch food closely when broiling. For best performance when broiling, center food below the broil heating element
Whole turkey	Bake	2 or 3	Use a low sided pan such as a broil pan.
Turkey Breast	Bake	2 or 3	Use a low sided pan such as a broil pan.
Fish	Broil Lo	6 (1/2 thick or less) 5 (>1/2 inch)	Watch food closely when broiling. For best performance center food below the broil heating element.
Casseroles	Bake	4	
Frozen Convenience Foods			
Pizza, french fries, tator tots, chicken nuggets, appetizers on a Single Rack	Bake	4	Use shiny cookware.
Pizza, french fries, tator tots, chicken nuggets, appetizers on Multiple Racks	Bake	3 and 5	Use shiny cookware.

*When baking four cake layers at a time, use racks 3 and 5. Place the pans as shown so that one pan is not directly above another.

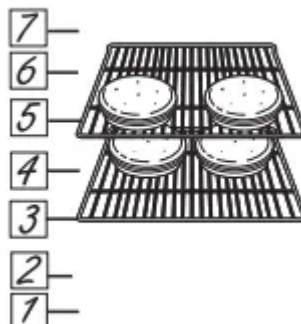

Rack position for baking 4 layer cakes.



CARE AND CLEANING

Cleaning the Range – Exterior

Be sure all controls are off and all surfaces are cool before cleaning any part of the range.

WARNING: If your range is removed for cleaning, servicing or any reason, be sure the antitip device is reengaged properly when the range is replaced. Failure to take this precaution could result in tipping of the range and can result in death or serious burns to children or adults.

Control Knobs

- The control knobs may be removed for easier cleaning. Make sure the knobs are in the OFF positions and pull them straight off the stems for cleaning.
- The knobs can be cleaned in a dishwasher or they may also be washed with soap and water. Make sure the inside of the knobs are dry before replacing.
- Replace the knobs, in the OFF position to ensure proper placement.

Control Panel

- It's a good idea to wipe the control panel after each use. Clean with mild soap and water or vinegar and water, rinse with clean water and polish dry with a soft cloth.
- Do not use abrasive cleansers, strong liquid cleansers, plastic scouring pads or oven cleaners on the control panel—they will damage the finish

Oven Exterior

- Clean with a mild soap and water or vinegar and water solution. Rinse with clean water and dry with a soft cloth. When cleaning surfaces, make sure that they are at room temperature and not in direct sunlight.
- If stain on the door vent trim is persistent, use a mild abrasive cleaner and a sponge-scrubber for best results.
- Spillage of marinades, fruit juices, tomato sauces and basting liquids containing acids may cause discoloration and should be wiped up immediately. Let hot surfaces cool, then clean and rinse.

Painted Surfaces

- Painted surfaces include the sides of the range and the door, top of control panel and the drawer front. Clean these with soap and water or a vinegar and water solution.
- Do not use commercial oven cleaners, cleaning powders, steel wool or harsh abrasives on any painted surface

Surface Units

To clean the surface units, turn the control to the highest setting for a minute. The coils will burn off any soil. To clean the Sensi-Temp Technology Sensor cap, wipe with a damp sponge or cloth. Do not use steel wool. Allow the burner to dry over night before re-installing it.

To remove a surface unit:

To remove the drip pans for cleaning, the surface units must be removed first.

1. Push the surface unit back toward the receptacle.
2. Lift the surface unit about 1 inch above the drip pan and pull it out.

NOTE: Repeated lifting of the surface unit more than 1 inch above the drip pan can permanently damage the receptacle

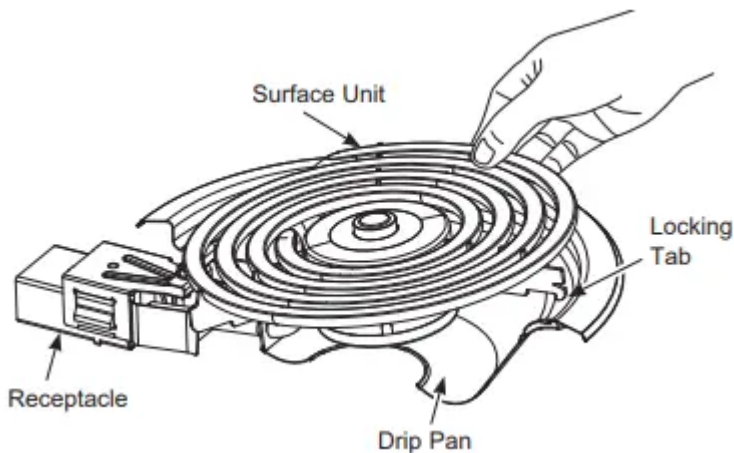

To replace a surface unit:

1. Replace the drip pan into the recess in the cooktop. Make sure the opening in the pan lines up with the receptacle.
2. Insert the terminals of the surface unit through the opening in the drip pan and into the receptacle.
3. Push the surface unit in and down so it rests evenly in the cooktop.

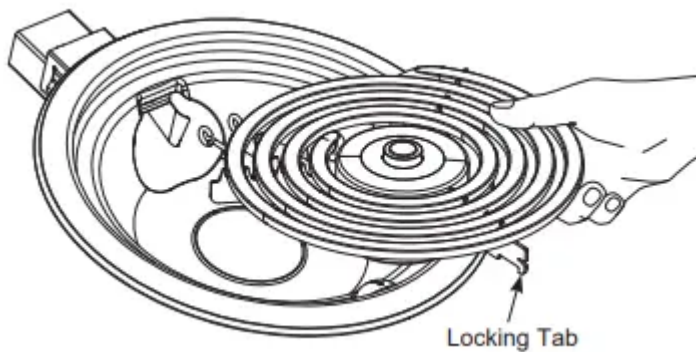

Drip Pans

- Remove the surface units. Then lift out the drip pans

- The drip pans may also be cleaned in a dishwasher.
- Clean the area under the drip pans often. Built-up soil, especially grease, may catch fire

NOTE: If your cooktop is equipped with shiny, silvercolored drip pans, do not clean them in the self-cleaning oven. Permanent damage to the finish can occur.

- If your cooktop is equipped with black or gray porcelaincoated drip pans, they can be cleaned in the oven during the self-cleaning cycle.
- Do not place the drip pans directly on the oven bottom. After the self-cleaning cycle is completed and the drip pans are cool, wipe them with a damp cloth to remove any remaining ash or residue.

Lift-Up Cooktop

- The entire cooktop may be lifted up and supported in the up position for easier cleaning.
- The surface units do not need to be removed; however, you may remove one to make raising the cooktop easier. There are two side supports that lock into position when the cooktop is lifted up.
- After cleaning under the cooktop with hot, mild soapy water and a clean cloth, lower the cooktop. Be careful not to pinch your fingers.
- To lower the cooktop, push the rods back and gently lower the cooktop until it rests in place.



Be sure all surface units are turned off before raising the Cooktop.

Control Lockout

- If desired, the touch pads may be deactivated before cleaning.
- See Lock Controls in the Oven Controls section.
- Clean up splatters with a damp cloth.
- You may also use a glass cleaner
- Reactivate the touch pads after cleaning.

Cleaning The Oven - Interior

- The interior of your new oven can be cleaned manually or by using Self Clean.

- Spillage of marinades, fruit juices, tomato sauces and basting liquids containing acids may cause discoloration and should be wiped up immediately. Let hot surfaces cool, then clean and rinse.

Self Clean Mode (on some models)

- Read Self-Cleaning Oven Safety Instructions at the beginning of this manual before using Self Clean Mode. Self clean uses very high temperatures to clean the oven interior. You will need to lock the oven door when using this feature. Before operating the self-clean cycle, wipe up grease and soils from the oven

NOTE: Never force the latch. If the oven is too hot, you will not be able to slide the latch. Allow the oven to cool. If your range has a knob turn knob to self clean position or if your range has an oven control press the Self Clean pad and a default self-clean time is displayed. The clean time can be changed to any time between 3:00 and 5:00 hours by using the +/- pads to enter a different time and pressing Start. For heavily soiled ovens, the maximum 5 hour clean time is recommended. If you wish to use the default time, press the Start pad immediately after pressing the Self Clean pad. The oven will turn off automatically when the self-clean cycle is complete and the self-clean light will be off. Slide the latch handle to the left as far as it will go and open the door. Never force the latch handle. Forcing the handle will damage the door lock mechanism. After the oven has cooled down wipe any ash out of the oven

- We recommend venting your kitchen with an open window or using a ventilation fan or hood during the first self-clean cycle.



- Soil on the front frame of the range and outside the gasket on the door will need to be cleaned by hand. Clean these areas with hot water, soap-filled steel-wool pads or cleansers such as Soft Scrub®. Rinse well with clean water and dry.
- Make sure the oven light bulb cover is in place and the oven light is off.

IMPORTANT: The health of some birds is extremely sensitive to the fumes given off during the self-cleaning cycle of any range. Move birds to another wellventilated room.

To Stop a Self-Clean Cycle

- Press Cancel/Off and wait for self clean light to go off. Wait until the oven has cooled below the locking temperature to unlatch the door. You will not be able to open the door right away unless the oven has cooled below the locking temperature.

Racks

- All racks can be washed with warm, soapy water.
- Racks may be more difficult to slide, especially after a self-clean. Put some vegetable oil on a soft cloth or paper towel and rub onto the left and right edges.

Oven Light

Oven Light Replacement (on some models)

To remove:

1. Turn the glass cover counterclockwise 1/4 turn until the tabs of the glass cover clear the grooves of the socket. Wearing latex gloves may offer a better grip.
2. Remove the bulb by turning it counter-clockwise.

To replace:

1. Replace bulb with a new 40-watt appliance bulb. Insert the bulb and turn it clockwise until it is tight.
2. Place the tabs of the glass cover into the grooves of the socket. Turn the glass cover clockwise 1/4 turn. For improved lighting inside the oven, clean the glass cover frequently using a wet cloth. This should be done when the oven is completely cool.
3. Reconnect electrical power to the oven.

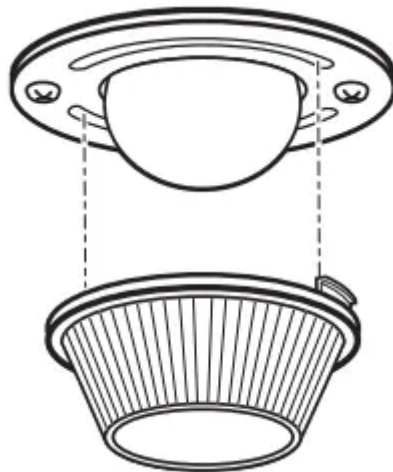

Glass cover on Self Clean models only.

Oven Door

To remove the door:

1. Fully open the door.
2. Pull the hinge locks down toward the door frame, to the unlocked position. A tool, such as a small flatblade screwdriver, may be required.

3. Firmly grasp both sides of the door at the top.
4. Close door to the door removal position. The door should be open approximately 3" with no obstruction above the door.
5. Lift door up and out until both hinge arms are clear of the slots.

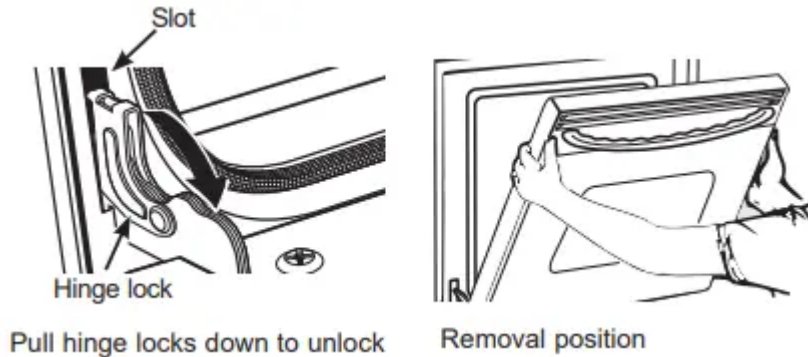

To replace the door:

1. Firmly grasp both sides of the door at the top.
2. Starting on the left side, with the door at the same angle as the removal position, seat the indentation of the hinge arm into the bottom edge of the hinge slot. The notch in the hinge arm must be fully seated into the bottom of the slot. Repeat for right side.
3. Fully open the door. If the door will not fully open, the indentation is not seated correctly in the bottom edge of the slot.
4. Push the hinge locks up against the front frame of the oven cavity, to the locked position.
5. Close the oven door.

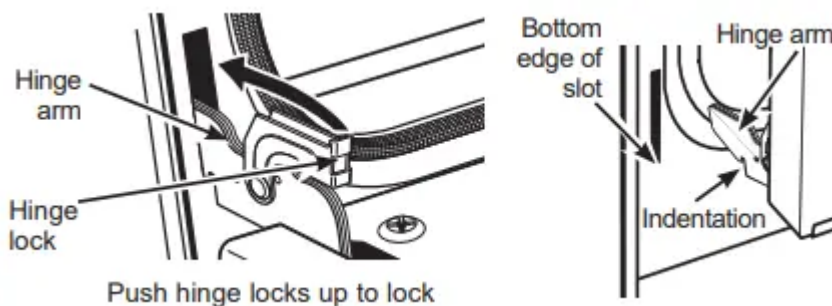

Storage Drawer (on some models)

To remove the drawer:

1. Pull the drawer out until it stops.
2. Lift the front of the drawer until the stops clear the guides.
3. Remove the drawer.

To replace the drawer:

1. Place the drawer rails on the guides.

2. Push the drawer back until it stops.
3. Lift the front of the drawer and push back until the stops clear the guides.
4. Lower the front of the drawer and push back until it closes.

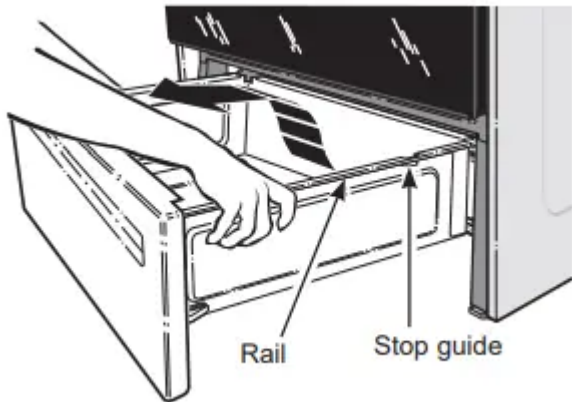

TROUBLESHOOTING TIPS

Save time and money! Review the charts on the following pages first and you may not need to call for service.

Surface units will not maintain a rolling boil or cooking is not fast enough

- Improper cookware being used.
 - Use pan which are flat and match the diameter of the surface unit selected.
- In some areas, the power(voltage) may be low
 - Cover pan with a lid until desired heat is obtained

Coil surface units do not work properly

- The surface units are not plugged in solidly
 - With the controls off, check to make sure the surface unit is plugged completely into the receptacle.
- The surface unit controls improperly set.
 - Check to see the correct control is set for the surface unit you are using.
- The drip pans are not set securely in the cooktop.
 - With the controls off, check to make sure the drip pan is in the recess in the cooktop and that the opening in the pan lines up with the receptacle.
- A fuse in your home may be blown or the circuit breaker tripped.
 - Replace the fuse or reset the circuit breaker.

- Sensi-Temp Technology sensor cap is overly soiled.
 - Clean Sensi-temp Technology sensor cap per cleaning the range section.
- Sensi-temp sensor cap stuck or will not flex up and down.
 - Call a qualified technician for replacement. Replace coil surface units with only the exact replacement part.

Frequent cycling off and on of surface units

- Improper cookware being used.
 - use only flat cookware to minimize cycling

My new oven doesn't cook like my old one. Is something wrong with the temperature settings?

- Your new oven has a different cooking system from your old oven and therefore may cook differently than your old oven.
 - For the first few uses, follow your recipe times and temperatures carefully. If you still think your new oven is too hot or too cold, you can adjust the temperature yourself to meet your specific cooking preference. NOTE: This adjustment affects Bake temperatures; it will not affect Broil or Clean.

Food does not bake properly

- Oven controls improperly set.
 - See the Cooking Modes section.
- Rack position is incorrect or rack is not level.
 - See the Cooking Modes section and Cooking Guide
- Incorrect cookware or cookware of improper size being used.
 - See the Cookware section.
- Oven temperature needs adjustment.
 - See the Special Features section
- Ingredient substitution
 - Substituting ingredients can change the recipe outcome.

Food does not broil properly

- Oven controls improperly set.
 - Make sure you select the appropriate broil mode.
- Improper rack position being used.
 - See Cooking Guide for rack location suggestions.

- Food being cooked in a hot pan.
 - Make sure cookware is cool.
- Cookware not suited for broiling.
 - Use a pan specifically designed for broiling
- Aluminum foil used on the broiling pan and grid has not been fitted properly and slit as recommended.
 - If using aluminum foil conform to pan slits.
- In some areas, the power(voltage) may be low
 - Preheat the broil element for 10 minutes.

Oven temperature too hot or too cold

- Oven temperature needs adjustment.
 - See the Special Features section or adjust the thermostat

Oven does not work or appears not to work

- A fuse in your home may be blown or the circuit breaker tripped.
 - Replace the fuse or reset the circuit breaker.
- Oven controls improperly set.
 - See the Using the oven section
- Oven is in Sabbath Mode.
 - Verify, that the oven is not in Sabbath Mode. See the Special Features section.

“Crackling” or “popping” sound

- This is the sound of the metal heating and cooling during both the cooking and cleaning functions.
 - This is normal.

Why is my range making a "clicking" noise when using my oven?

- Your range cycles the heating elements by turning relays on and off to maintain the oven temperature.
 - This is normal.

Clock and timer do not work

- A fuse in your home may be blown or the circuit breaker tripped.
 - Replace the fuse or reset the circuit breaker.

- Plug on range is not completely inserted in the electrical outlet.
 - Make sure electrical plug is plugged into a live, properly grounded outlet.
- Oven controls improperly set.
 - See the Using the kitchen timer section

Storage drawer won't close

- Power cord may be obstructing drawer in the lower back of the range.
 - Reposition the drawer and power cord.
- Rear drawer support is on top of the guide rail.
 - Reposition the drawer

Oven door is crooked

- The door is out of position.
 - Because the oven door is removable, it sometimes gets out of position during installation. To straighten the door, push down on the high corner.

Oven light does not work

- Light bulb is loose or defective.
 - Tighten or replace bulb.
- Pad operating light is broken.
 - Call for service.

Oven will not self-clean

- The temperature is too high to set a self-clean operation.
 - Allow the oven to cool and reset the controls.
- Oven controls improperly set.
 - See the Cleaning the Oven section.

Excessive smoking during clean cycle

- Excessive soil or grease.
 - Press the Cancel/Off pad. Open the windows to rid the room of smoke. Wait until the LOCKED light goes off. Wipe up the excess soil and reset the clean cycle.

Excessive smoking during broiling

- Food too close to burner element.
 - Lower the rack position of the food.

Oven door will not open after a clean cycle

- Oven too hot.
 - Allow the oven to cool below locking temperature.

Oven not clean after a clean cycle

- Oven controls improperly set.
 - See the Cleaning the Oven section.
- Oven was heavily soiled.
 - Clean up heavy spillovers before starting the clean cycle. Heavily soiled ovens may need to self-clean again or for a longer period of time

"LOCK DOOR" flashes in the display

- The self-clean cycle has been selected but the door is not closed.
 - Close the oven door.

DOOR LOCK light is on when you want to cook

- The oven door is locked because the temperature inside the oven has not dropped below the locking temperature
 - Press the Cancel/Off pad. Allow the oven to cool.

"F— and a number or letter" flash in the display

- You have a function error code.
 - Press the Cancel/Off pad. Allow the oven to cool for one hour. Put the oven back into operation.
- If the function code repeats.
 - Disconnect all power to the oven for at least 30 seconds and then reconnect power. If the function error code repeats, call for service.

Display goes blank

- A fuse in your home may be blown or the circuit breaker tripped
 - Replace the fuse or reset the circuit breaker.
- The clock is turned off.
 - See the Special features section.
- Oven is in Sabbath Mode.
 - Verify that the oven is not in Sabbath Mode. See the Special Features section.

Power outage, clock flashes

- Power outage or surge
 - Reset the clock. If the oven was in use, you must reset it by pressing the Cancel/Off pad, setting the clock and resetting any cooking function.

“Burning” or “oily” odor emitting from the vent

- This is normal in a new oven and will disappear in time.
 - To speed the process, set a self-clean cycle for a minimum of 3 hours. See the Cleaning the Oven section

Strong odor

- An odor from the insulation around the inside of the oven is normal for the first few times the oven is used.
 - This is temporary and will go away after several uses or a self-clean cycle.

My oven door glass appears to be "tinted" or have a "rainbow" color. Is this defective?

- No. The inner oven glass is coated with a heat barrier to reflect the heat back into the oven to prevent heat loss and keep the outer door cool while baking
 - This is normal. Under certain lights or angles, you may see this tint or rainbow color.

Sometimes the oven takes longer to preheat to the same temperature

- Cookware or food in oven.
 - The cookware or food in the oven will cause the oven to take longer to preheat. Remove items to reduce preheat time.
- Number of racks in oven.
 - Adding more racks to the oven will cause the oven to take longer to preheat. Remove some racks.

Display flashes

- Power failure.
 - Reset the clock.

Unable to get the display to show “SF”

- Oven control pads were not touched properly
 - The Broil Hi/Lo and Bake pads must be touched at the same time and held for 3 seconds

Control signals after entering cooking time or start time

- You forgot to enter a bake temperature or cleaning time
 - Touch the Bake pad and desired temperature or the Self Clean pad and desired clean time.

Oven racks are difficult to slide

- The shiny, silver-colored racks were cleaned in a self-clean cycle.
 - Apply a small amount of vegetable oil to a paper towel and wipe the edges of the oven racks with the paper towel. Do not spray with Pam or other lubricant sprays.

Drawer does not slide smoothly or drags

- The drawer is out of alignment
 - Fully extend the drawer and push it all the way in See the Care and cleaning of the range section.
- Drawer is over-loaded or load is unbalanced
 - Reduce weight. Redistribute drawer contents.

Steam from the vent

- When using the ovens, it is normal to see steam coming out of the oven vents. As the number of racks or amount of food being cooked increases, the amount of visible steam will increase.
 - This is normal.

Excessive condensation in the drawer

- Liquid in drawer.
 - Remove liquid.
- Uncovered food
 - Cover food with lid or aluminum foil.
- Temperature setting too high.
 - Reduce temperature setting.

Warning

This content is compiled from multiple sources and is provided for reference purposes only. It may not be complete or fully applicable to all situations. If you are unable to resolve your issue, please contact the product manufacturer or an authorized service provider for official support.

