

Operating Instructions

About the features of your oven.

Throughout this manual, features and appearance may vary from your model.

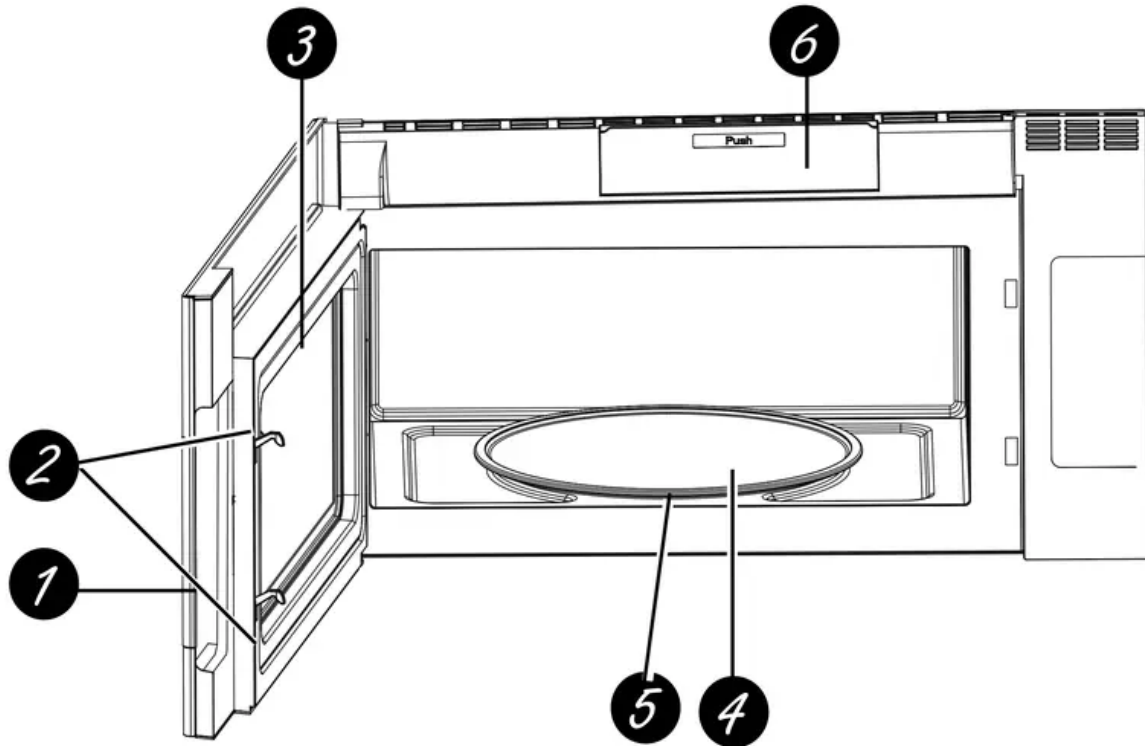

Features of the Oven

1. **Door Handle.**
2. **Door Latches.**
3. **Window with Metal Shield.** Screen allows cooking to be viewed while keeping microwaves confined in the oven.
4. **Removable Turntable.** Do not operate the oven in the microwave mode without the turntable and turntable support seated and in place.
5. **Removable Turntable Support.** Do not operate the oven in the microwave mode without the turntable and turntable support seated and in place.
6. **Charcoal Filter Cover.** Push the cover to replace the charcoal filter without taking the unit off from cabinet.

About the cooking features of your microwave oven.

Throughout this manual, features and appearance may vary from your model.

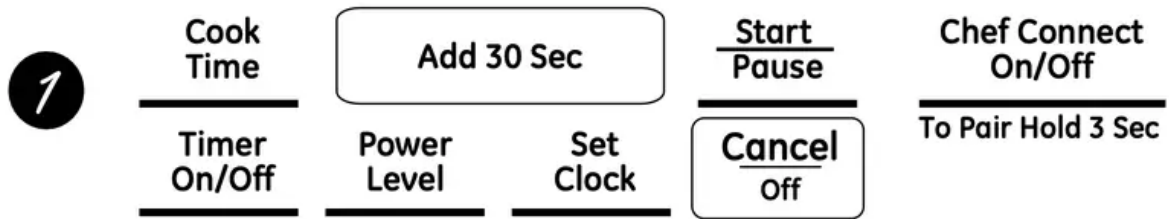

Sensor Cooking -

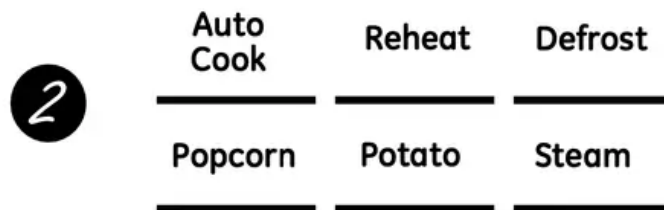

Cooking Controls

Check the Convenience Guide before you begin.

1 Time Features

Press	Enter
COOK TIME	Amount of cooking time
DEFROST	Weight or time
TIMER	
POWER LEVEL	Power level 1 to 10
ADD 30 SEC	Starts immediately!
EXPRESS COOK	Starts immediately!

2 Sensor/Convenience Features

Press	Enter
AUTO COOK	Press pad to select food
POPCORN	Start immediately
REHEAT	Press pad to select food
POTATO	Start immediately
STEAM	Press pad to select food

About the time features.

Cook Time

Cook Time

Express Cook

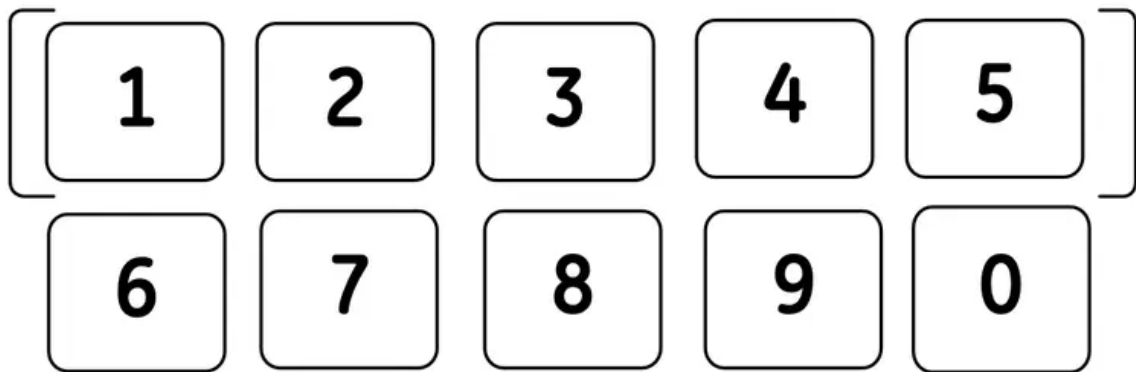

Start Pause

Allows you to microwave for any time up to 99 minutes and 99 seconds.

Power level 10 (HIGH) is automatically set, but you may change it for more flexibility.

1. Press Cook Time.
2. Enter cooking time.
3. Press START.

Cooking will start when the countdown begins in the display.

You may open the door during Cook Time to check the food. Close the door and press START to resume cooking.

Express Cook

Express Cook

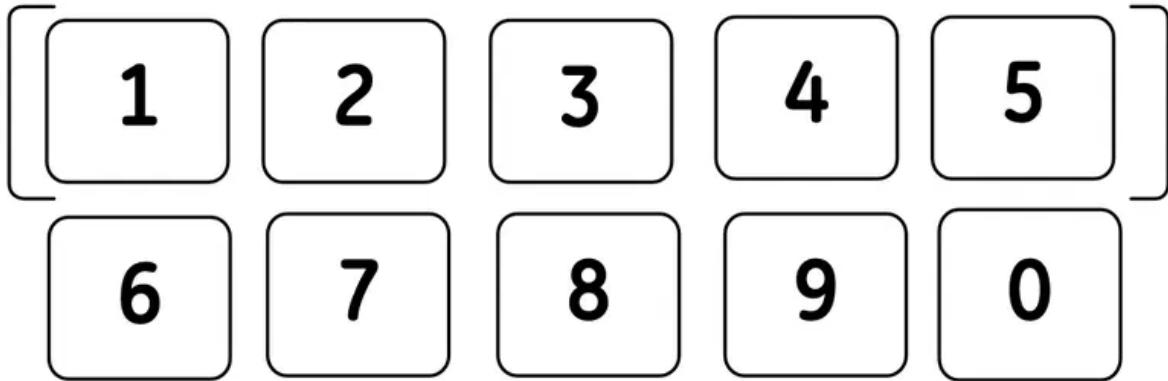

This is a quick way to set cooking time for 1-5 minutes.

1. Press one of the Express Cook pads (from 1-5) for 1-5 minutes of cooking at power level 10.

For example, press the 2 pad for 2 minutes of cooking time.

The power level can be changed as time is counting down. Press POWER LEVEL and enter 1-10.

NOTE: Express Cook function pertains to pads 1-5 only.

Add 30 Sec



This will add 30 seconds to the time counting down each time the pad is pressed. Each touch will add 30 seconds, up to 99 minutes and 99 seconds.

Add 30 sec can also be used like an express 30 seconds button. The microwave oven will start immediately when pressed.

About the defrost features.

Weight Defrost

Defrost

Express Cook

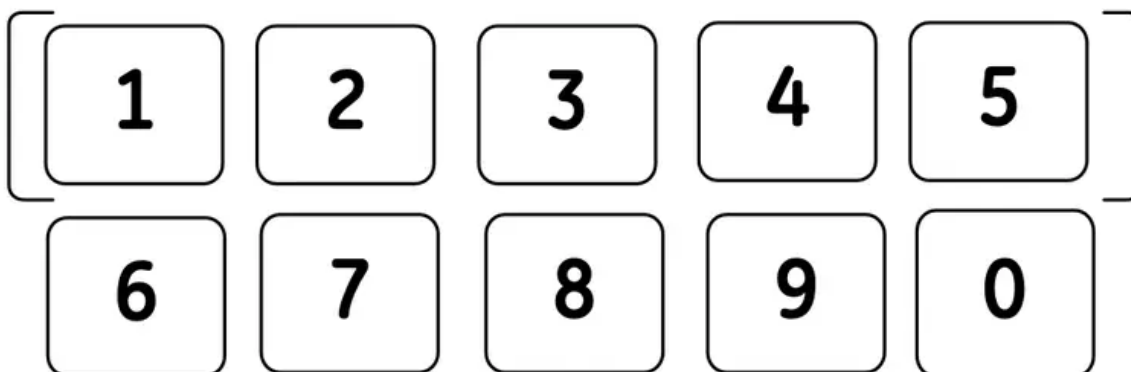

Start Pause

Use Weight Defrost for meat, poultry and fish. use Time Defrost for most other frozen foods. (Time Defrost is explained on page 13.)

1. Press DEFROST once for Weight Defrost.
2. Enter the weight in pounds.
3. Press START.

Cooking will start when the countdown begins in the display.

Defrosting Tips

- Remove meat from package and place on microwave-safe dish.
- When the oven signals, turn the food over. Remove defrosted meat or shield warm areas with small pieces of foil.
- After defrosting, most meats need to stand 5 minutes to complete defrosting. Large roasts should stand for about 30 minutes.

Conversion Guide

If the weight of food is stated in pounds and ounces, the ounces must be converted to tenths (.1) of a pound.	
Ounces	Pounds
1-2 (28-57 g)	.1
3 (85 g)	.2
4-5 (113-142 g)	.3
6-7 (170-198 g)	.4
8 (227 g)	.5
9-10 (255 g)	.6
11 (312 g)	.7
12-13 (340-369 g)	.8
14-15 (397-425 g)	.9

Note: Max 6.0 lbs. (2.7 kg)

Time Defrost



Defrost

Express Cook

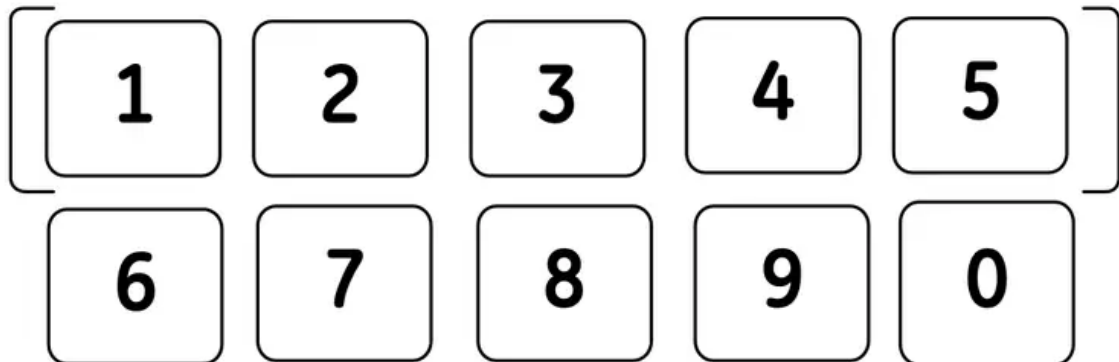

Start Pause

Allows you to defrost for a selected length of time. See the Defrosting guide on page 14 for suggested times (Weight Defrost is explained on page 12).

1. Press DEFROST twice for Time Defrost.
2. Enter defrosting time in minutes and seconds.
3. Press START.

Cooking will start when the countdown begins in the display.

At one half of selected defrosting time, turn food over and break apart or rearrange pieces for more even defrosting. Shield any warm areas with small pieces of foil. The oven will continue to defrost if you don't open the door and turn the food.

Noises may be heard during defrosting. This is normal when oven is not operating at High power.

Defrosting Tips

- Foods frozen in paper or plastic can be defrosted in the package. Closed packages should be slit, pierced or vented AFTER food has partially defrosted. Plastic storage containers should be partially uncovered.

- Family-size, prepackaged frozen dinners can be defrosted and microwaved. If the food is in a foil container, transfer it to a microwave-safe dish.
- Foods that spoil easily should not be allowed to sit out for more than one hour after defrosting. Room temperature promotes the growth of harmful bacteria.
- For more even defrosting of larger foods, such as roasts, use Time Defrost. Be sure large meats are completely defrosted before cooking.
- When defrosted, food should be cool but softened in all areas. If still slightly icy, return to the microwave very briefly, or let it stand a few minutes.

Defrosting Guide

FOOD	TIME	COMMENTS
Bread, Cakes Bread, buns, or rolls (1 piece) Sweet rolls (approx. 12 oz/340g)	1/4 min. 2 to 4 min.	Rearrange after half the time
Fish and Seafood Fillets, Frozen (1 lb/454 g)	6 to 9 min.	
Fruit Plastic Pouch - 1 or 2 (10 oz/284 g package)	1 to 5 min.	
Meat Bacon (1 lb/454 g) Franks (1 lb/454 g) Ground meat (1 lb/454 g) Roast: beef, lamb, veal, pork Steaks, chops and cutlets	2 to 5 min. 2 to 5 min. 4 to 6 min. 9 to 13 min. per lb./454 g 4 to 8 min. per lb./454 g	Place unopened package in oven. Let stand 5 minutes after defrosting. Place unopened package in oven. Microwave just until franks can be separated. Let stand 5 minutes, if necessary, to complete defrosting. Turn meat over after first half of time. Use power level 10. Place unwrapped meat in cooking dish. Turn over after first half of time and shield warm areas with foil. After second half of time, separate pieces with table knife. Let stand to complete defrosting.
Poultry Chicken, broiler-fryer, cut up (2½ to 3 lbs./1.1 to 1.4 kg) Chicken, whole (2½ to 3 lbs./1.1 to 1.4 kg) Cornish hen Turkey breast (4 to 6 lbs./1.8 to 2.7 kg)	14 to 20 min. 20 to 25 min. 7 to 13 min. per lb./454 g 3 to 8 min. per lb./454 g	Place wrapped chicken in dish. Unwrap and turn over after first half of time. After second half of time, separate pieces and place in cooking dish. Microwave 2 to 4 minutes more, if necessary. Let stand a few minutes to finish defrosting. Place wrapped chicken in dish. After half the time, unwrap and turn chicken over. Shield warm areas with foil. To complete defrosting, run cold water in the cavity until giblets can be removed. Place unwrapped hen in the oven breast-side up. Turn over after first half of time. Run cool water in the cavity until giblets can be removed. Place unwrapped breast in microwave-safe dish breast-side down. After first half of time, turn breast-side up and shield warm areas with foil. Defrost for second half of time. Let stand 1 to 2 hours in refrigerator to complete defrosting.

About the sensor features.

The Sensor Features detect the increasing humidity released during cooking. The oven automatically adjust the cooking time to various types and amounts of food.

Do not use the Sensor Features twice in succession on the same food portion - it may result in severely overcooked or burnt food. Be sure to let the oven cool down for 5 - 10 minutes before starting the next sensor cook.

If food is undercooked after the countdown, use Cook Time for additional cooking time

- The proper containers and covers are essential for best sensor cooking.
- Always use microwave-safe containers and cover them with lids or vented plastic wrap. Never use tight-sealing plastic covers - they can prevent steam from escaping and cause food to overcook.
- Be sure the outside of the cooking container and the inside of the microwave oven are dry before placing food in the oven. Beads of moisture turning into steam can mislead the sensor.

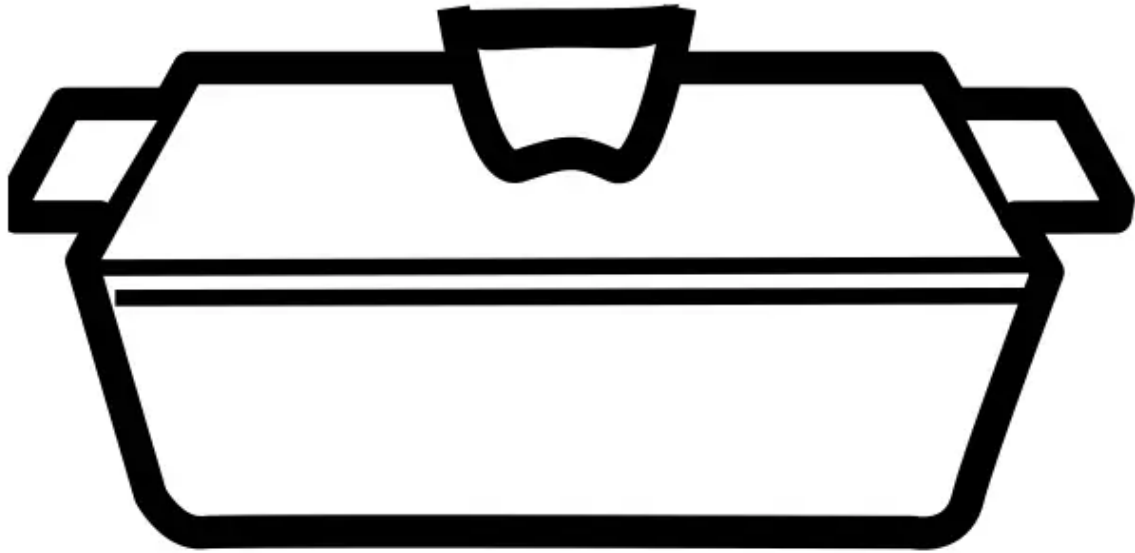

Covered



Vented

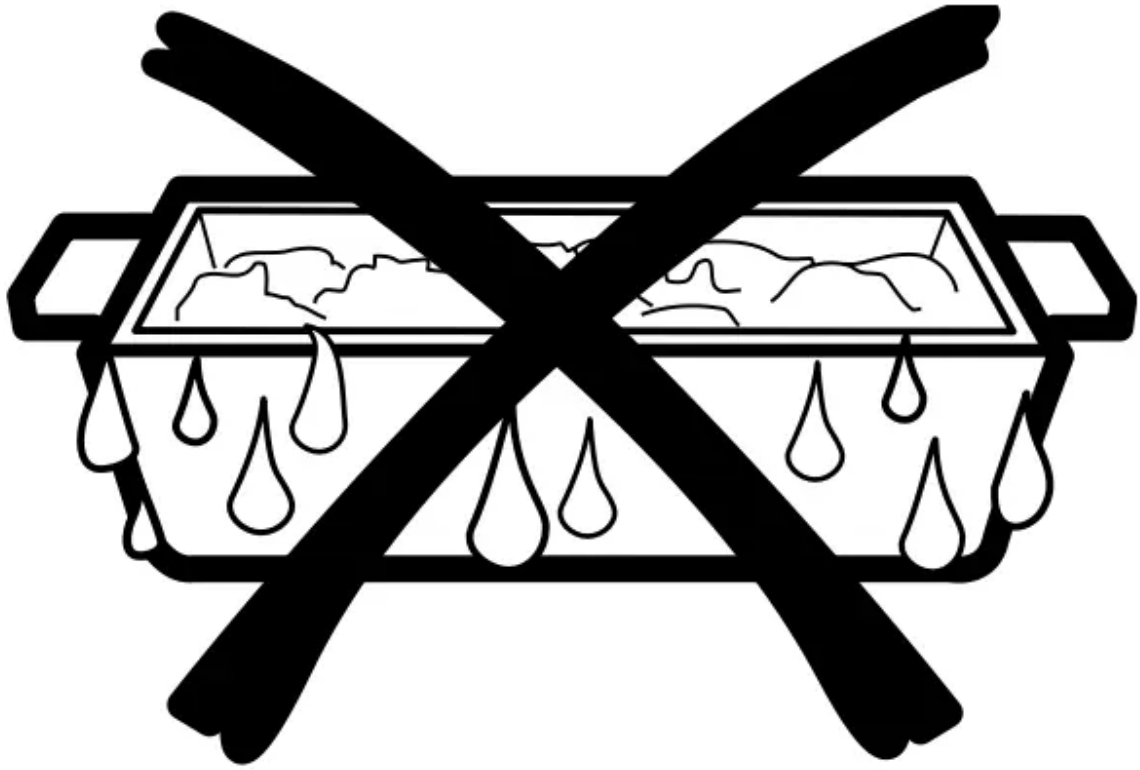

Dry off dishes so they don't mislead the sensor.

Auto Cook

Auto Cook

Express Cook

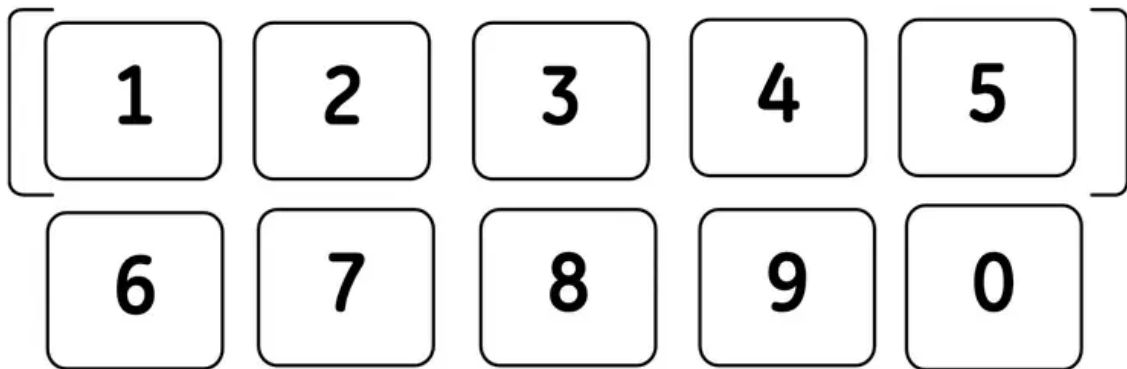

Start Pause

Allows you to microwave food choices with sensor.

1. Press AUTO COOK button.
2. Enter the food type code. See Cooking guide for auTO COOK below for codes or check the display for food types.
3. Press START.

The oven signals when steam is sensed and the time remaining begins counting down.

Do not open the oven door until time is counting down. if the door is opened before time is counting down 4 beeps are emitted while the display will Scroll & Cycle "SEnSOR ERROR " until CANCEL is pressed. The sensor cook will be cancelled as well. if the Door is opened during the counting down, close it and press START immediately.

Cooking Guide for Auto Cook Feature

CODE ENTRY	FOOD	COMMENTS
1	Chicken	
2	Fish	
3	Ground Meat	
4	Veggies	Enter veggies type 1 Fresh Veggies 2 Frozen Veggies 3 Canned Veggies

How to Change the Automatic Settings

To reduce time by 10%: Press 1 after the feature pad.

To add 10% to cooking time: Press 9 after the feature pad.

Popcorn

Popcorn



To use the Popcorn feature:

1. Place the package of popcorn in the center of the microwave.
2. Press POPCORN. The oven starts immediately.

Your popcorn bag may get stuck and stop rotating, but this will not affect the cooking performance. Do not open the door even if the bag is not rotating.

How to Change the Automatic Settings

To reduce time by 10%: Press 1 after the feature pad.

To add 10% to cooking time: Press 9 after the feature pad.

If food is undercooked after the countdown, use Cook Time for additional cooking time. We recommend 30 seconds and watch carefully.

Reheat

Reheat



The Reheat feature reheats servings of previously cooked foods or a plate of leftovers.

1. Press REHEAT.
2. Using the cooking guide below, enter food code. For example, 1 for Pasta.
3. Press START/PAUSE. The oven signals when steam is sensed and the time remaining begins counting down.

Do not open the oven door until time is counting down. If the door is opened before time is counting down 4 beeps are emitted while the display will Scroll & Cycle "SEnSOR ERROR " until CANCEL is pressed. The sensor cook will be cancelled as well. If the Door is opened during the counting down, close it and press START immediately.

After removing food from the oven, stir, if possible, to even out the temperature. If the food is not hot enough, use Cook Time to reheat for more time. Reheated foods may have wide variations in temperature. Some areas may be extremely hot.

It is best to use Cook Time for these foods:

- Bread products.
- Foods that must be reheated covered.
- Foods that need to be stirred or rotated during reheating.
- Foods calling for a dry look or crisp surface after reheating.

How to Change the Automatic Settings

To reduce time by 10%: Press 1 after the feature pad.

To add 10% to cooking time: Press 9 after the feature pad.

Cooking Guide for Reheat Feature:

Code Entry	Food
1	Pasta
2	Pizza
3	Plate
4	Soup

Potato

Potato



To use the Potato feature:

1. Place the potato in the center of the microwave.
2. Press POTATO.
The oven starts immediately.

Do not open the oven door until time is counting down. if the door is opened before time is counting down 4 beeps are emitted while the display will Scroll & Cycle "SEnSOR ERROR " until CANCEL is pressed. The sensor cook will be cancelled as well. if the Door is opened during the counting down, close it and press START immediately.

How to Change the Automatic Settings

To reduce time by 10%: Press 1 after the feature pad.

To add 10% to cooking time: Press 9 after the feature pad.

Microwave terms.

Term	Definition
Arcing	Arcing is the microwave term for sparks in the oven. Arcing is caused by: <ul style="list-style-type: none">• metal or foil touching the side of the oven.• foil that is not molded to food (upturned edges act like antennas).• metal such as twist-ties, poultry pins, gold-rimmed dishes.• recycled paper towels containing small metal pieces.
Covering	Covers hold in moisture, allow for more even heating and reduce cooking time. Venting plastic wrap or covering with wax paper allows excess steam to escape.
Shielding	In a regular oven, you shield chicken breasts or baked foods to prevent over-browning. When microwaving, you use small strips of foil to shield thin parts, such as the tips of wings and legs on poultry, which would cook before larger parts.
Standing Time	When you cook with regular ovens, foods such as roasts or cakes are allowed to stand to finish cooking or to set. Standing time is especially important in microwave cooking. Note that a microwaved cake is not placed on a cooling rack.
Venting	After covering a dish with plastic wrap, vent the plastic wrap by turning back one corner so excess steam can escape.

About the steam features.

Steam

Steam

Express Cook

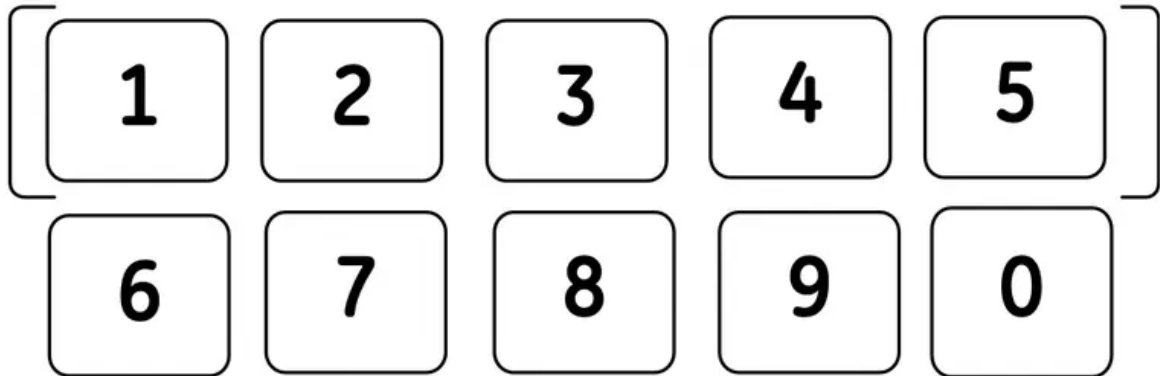

Start Pause

Use the STEAM feature to steam certain preprogrammed foods.

1. Press STEAM button.
2. Enter the food type code you wish to steam. See Cooking guide for STEAM below for codes or check the display for food types.
3. Place steamer bowl with water, salt (if necessary), and food in the microwave with the steam vents on the steamer bowl in the OPEN position.
4. Press START button to begin cooking.

NOTE: The NordicWare Rice Cooker/Steamer Bowl should be used for best cooking results.

Cooking Guide for Steam Feature

Code Entry	Food	Amount Entry
1	Rice	1 - 1 cup (240 mL) white 2 - 1 cup (240 mL) brown
2	Asparagus	1 - 1 cup (240 mL) 2 - 2 cups (480 mL)
3	Broccoli	1 - 1 cup (240 mL) 2 - 2 cups (480 mL)
4	Brussel Sprouts	1 - 1 cup (240 mL) 2 - 2 cups (480 mL)
5	Carrots	1 - 1 cup (240 mL) 2 - 2 cups (480 mL)
6	Cauliflower	1 - 1 cup (240 mL) 2 - 2 cups (480 mL)
7	Zucchini	1 - 1 cup (240 mL) 2 - 2 cups (480 mL)

About the Power Level features.

Changing the Power Level

Power Level

Express Cook

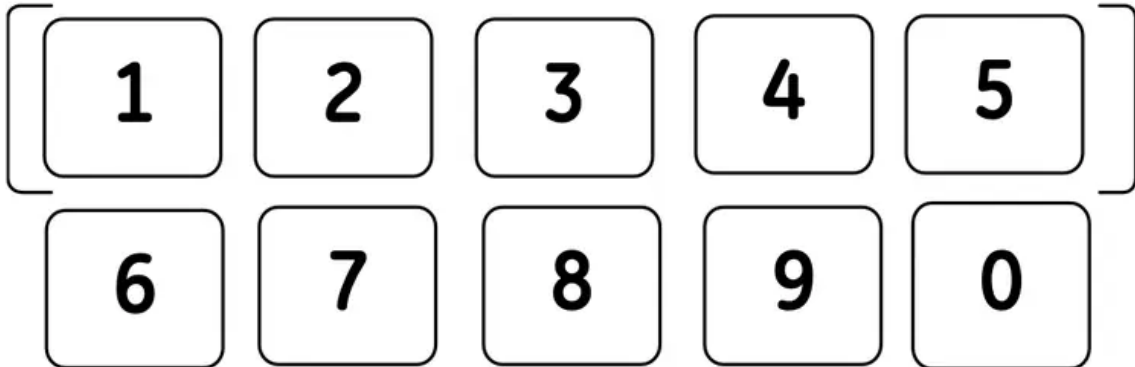

Start Pause

The power level may be entered or changed before or during cooking. Power Level is set for Level 10 (High) unless it is changed.

1. Press Power Level button.
2. Enter new power level by using the number pads or press the Power Level button multiple times until you find the level you want.
3. After you have selected the power level, wait five seconds. The display will go back to the Cook Time screen.
4. Enter cooking time and press START.

OR

1. Press Cook Time button.
2. Enter your cooking time.
3. Press Power Level button.

4. Enter new power level by using the number pads or press the Power Level button multiple times until you find the level you want.
5. After you have selected the power level, wait five seconds. The display will go back to the Cook Time (Enter Time) screen.
6. Press START.

Variable power levels add flexibility to microwave cooking. The power levels on the microwave oven can be compared to the surface units on a range. Each power level gives you microwave energy a certain percent of the time. Power level 7 is microwave energy 70% of the time. Power level 3 is energy 30% of the time. Most cooking will be done on High (power level 10) which gives you 100% power. Power level 10 will cook faster but food may need more frequent stirring, rotating or turning over. a lower setting will cook more evenly and need less stirring or rotating of the food. Some foods may have better flavor, texture or appearance if one of the lower settings is used. use a lower power level when cooking foods that have a tendency to boil over, such as scalloped potatoes and some casseroles.

Rest periods (when the microwave energy cycles off) give time for the food to “equalize” or transfer heat to the inside of the food. an example of this is shown with Power level 3—the defrost cycle. If microwave energy did not cycle off, the outside of the food would cook before the inside was defrosted.

Here are some examples of uses for various power levels:

High 10 (100%): Fish, bacon, vegetables, boiling liquids.

Med-High 7 (70%): gentle cooking of meat and poultry; baking casseroles and reheating.

Medium 5 (50%): Slow cooking and tenderizing for stews and less tender cuts of meat.

Low 2 or 3 (20 or 30%): Defrosting; simmering; delicate sauces.

Warm 1 (10%): Keeping food warm; softening butter.

NOTE: You can also change the power level during many cooking modes by pressing the power level button entering a valid power level.

About the other features.

Clock

Set Clock

To change the time of day.

1. Press the Set Clock button. (The microwave should not be running.)
2. Enter the appropriate time of day. Clock is on a 12-hour scale.
3. Press Set Clock or Start to accept the time.

Start/Pause

In addition to starting many functions, START/ PAUSE allows you to stop cooking without opening the door or clearing the display and resume cooking later.

Start Pause

Cancel/Off

Press the CANCEL/OFF button to stop and cancel cooking at any time.

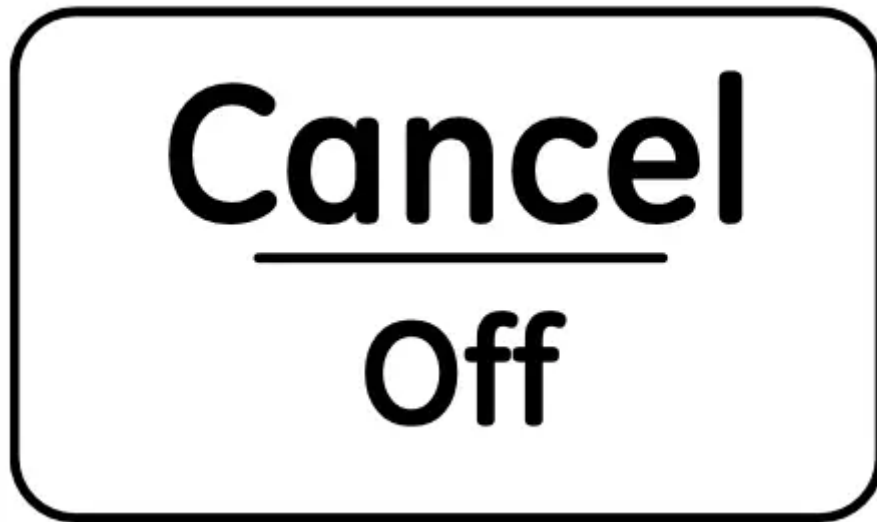

Control Lock-Out

**Lock
Control**

Hold 3 Sec

You may lock the control panel to prevent the oven from being accidentally started during cleaning or being used by children.

To lock or unlock the controls, press and hold the LOCK CONTROL button for three seconds. When the control panel is locked, LOCKED will be displayed briefly anytime a button or dial is pressed. "L" will show in the display.

Surface Light

Surface Light

Press SURFACE LIGHT once for low light, twice for high light or a third time to turn the light off.

Note: If the microwave is working and the vent fan is on Boost speed, the surface lights will be turned to low light automatically.

Timer

Timer On/Off

NOTE: The Timer indicator will be lit while the timer is operating.

The Timer operates as a minute timer and can be used at any time, even when the oven is operating.

1. Press the Timer button.
2. Enter a time.
3. Press the Timer button to start.

To cancel, press the Timer button.

When time is up, the oven will signal. To turn off the timer signal, press Timer.

Display

If you have the Timer counting down and you are using the Cook Time at the same time, you can change the display to show either the timer or the cook time countdown.

If the display shows the time for the Timer and you would like to view the Cook Time, press the COOK TIME button.

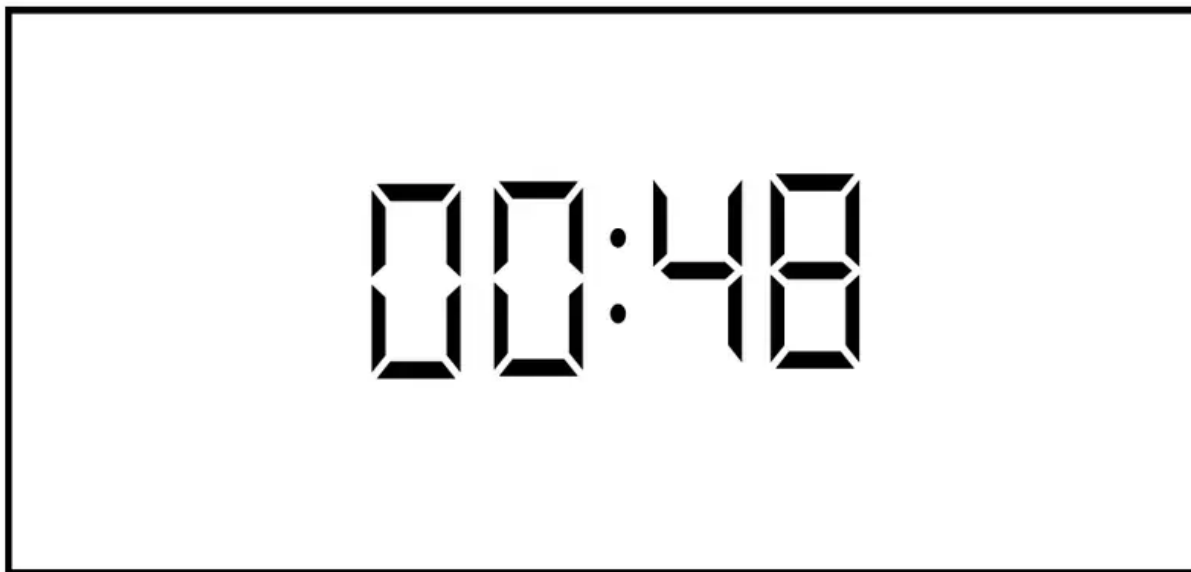

If the display shows the time for the Cook Time and you would like to view the Timer, press the TIMER button.



Turntable

Turntable

For best cooking results, leave the turntable on. It can be turned off for large dishes.

Press the Turntable pad once to turn the turntable off. Press again to turn the turntable back on.

Sometimes the turntable can become too hot to touch. Be careful touching the turntable during and after cooking.

Turntable can be turned off during the Cook Time or Express Cook features by pressing the Turntable pad.

Note: At the conclusion of the Cook Time and Express Cook features, the turntable will automatically return to On.

Vent Fan

Vent Fan

The vent fan removes steam and other vapors from surface cooking.

Press Vent Fan once for low fan speed, twice for medium fan speed, three times for high fan speed, four times for boost speed or five times to turn the fan off

Automatic Fan

An automatic fan feature protects the microwave from too much heat rising from the cooktop below it. It automatically turns on if it senses too much heat.

If you have turned the fan on you may find that you cannot turn it off. The fan will automatically turn off when the internal parts are cool. It may stay on for 30 minutes or more after the cooktop and microwave controls are turned off.

Insert Food Reminder

A reminder will show on the display if the user tries to start the cooking cycle without placing food inside the microwave oven within 5 minutes prior to starting the cooking cycle.

Cooking Complete Reminder

To remind you that you have food in the oven, the oven will display "Food is ready" and beep once a minute until you either open the oven door or press the CANCEL/OFF button.

Settings

Settings

Settings allow to change the default settings of your OTR.

1. Press the Settings pad. "SELECT SETTING ITEM 1 - BEEPER VOLUME, 2 - CLOCK MODE, 3 - DISPLAY ON/OFF, 4 - LIGHT SYNC, 5 VENT FAN SYNC, 6 - SYNC AUTO OFF, or 7 - EXIT" will scroll and repeat on display.
2. Select the item to change the settings. See below tables for detail guide

Code Entry	Items for setting	Level Entry
1	Beeper Volume	0 - Mute 1 - Low 2 - Normal 3 - Loud Default is normal
2	Clock Mode	0 - 12 hours 1 - 24 hours Default is 12 hours
3	Display On/Off	0 - Off 1 - On Default is On
4	Light Sync - Selects the light level at which the surface lights will automatically turn on when paired range's burner is turned on. Select "Off" to disable this feature. Surface light will turn on manually.	0 - Off 1 - Low 2 - High Default is High
5	Vent Fan Sync - Selects the fan speed at which the vent fan will automatically turn on when paired range's burner is turned on. Select "Off" to disable this feature. Vent fan will turn on manually.	0 - Off 1 - Low 2 - Medium 3 - High 4 - Boost Default is OFF
6	Sync Auto Off - When the Light/Vent fan sync mode is enabled (ON), this will automatically turn OFF the light/fan when the range burner has been turned off. Select the period of time the light/fan will remain on until the microwave automatically turns it off.	0 - 0 minutes 1 - 5 minutes 2 - 10 minutes 3 - 15 minutes 4 - Manual Default is 15 minutes
7	Settings Exit	1 - Exit

Chef Connect

Chef Connect On/Off

To Pair Hold 3 Sec

Use the Chef Connect feature for connecting your microwave to a GE Range to sync your vent fan, cooktop surface lights and clock via Bluetooth technology.

1. You must have a Chef Connect enabled range. To pair your microwave for the first time, initiate the Chef Connect process on the GE Range. Refer to the range owner's manual for instructions

2.

On the microwave, hold Chef Connect button for 3 seconds. The Bluetooth icon  on the display will start flashing as the microwave starts to search and pair with your GE

Range. The icon  will remain On after pairing successfully.

If a GE Range is not found within 2 minutes during search mode the microwave will stop

searching and the Bluetooth icon  will turn OFF.

On initial setup, the setup protocol will start.

If the Chef Connect feature is enabled the default settings are as follows:

Display clock sync: ON

Auto cooktop light: On (HIGH setting)

Auto vent fan: OFF

Auto off: 15 minutes

3. Select 1 to sync the surface lights to your GE range. it allows the microwave surface lights to turn on at HIGH level automatically when the paired range's cooktop burner turns on.
4. Select 1 to sync the vent fan to your GE range. This allows the microwave vent fan to turn on at LOW speed automatically when the paired range's cooktop burner turns on. Pairing is now complete, the Chef Connect feature is now on.

Note: if there is no sync option selected during set up, 5 minutes after icon  turns on, the units will return to stand-by mode.

After completing the setting per above steps, your microwaves vent fan and cooktop light will be set to turn on automatically when the cooktop burner is turned on. The cooktop and range clock display will be syncd to display the same time. The vent fan and cooktop light will be set to automatically turn off 15 minutes after the cooktop burner is turned off. If desired, the light, fan, and auto off settings can now be changed using settings options 4, 5, and 6, respectively.

Press Chef Connect once to turn off and twice to re-connect. The icon  will illuminate when on.

In the case of an unintended disconnect such as lost power to the microwave or range the connection will remain after power resumed. For very short power interruptions, the power may need to be reset in order to reconnect.

Reset Filter

Reset Filter



Hold 3 Sec

The red LED indicator will light every 6 months as a reminder to replace the charcoal filter.

after replacing the charcoal filters, Hold the Rest Filter for 3 seconds to turn off the Red LED indicator.

Charcoal Filter

The charcoal filter cannot be cleaned. It must be replaced. Order Part No. WB02X11550 from your GE supplier.

If the model is not vented to the outside, the air will be recirculated through a disposable charcoal filter that helps remove smoke and odors.

The charcoal filter should be replaced when the red LED indicator lights under the Reset Filter pad. See “Optional Kits,” page 8, for more information.

To Remove The Charcoal Filter

To **remove the charcoal filter**, first disconnect power at the main fuse or circuit breaker, or pull the plug. Open the microwave oven door and push the “Push” area on charcoal filter cover at center of the grille. Press back on the top of the filter with both hands until the filter lays down almost horizontal. Lift the filter at the bottom until it comes free of the tabs. Slide the filter down and out.

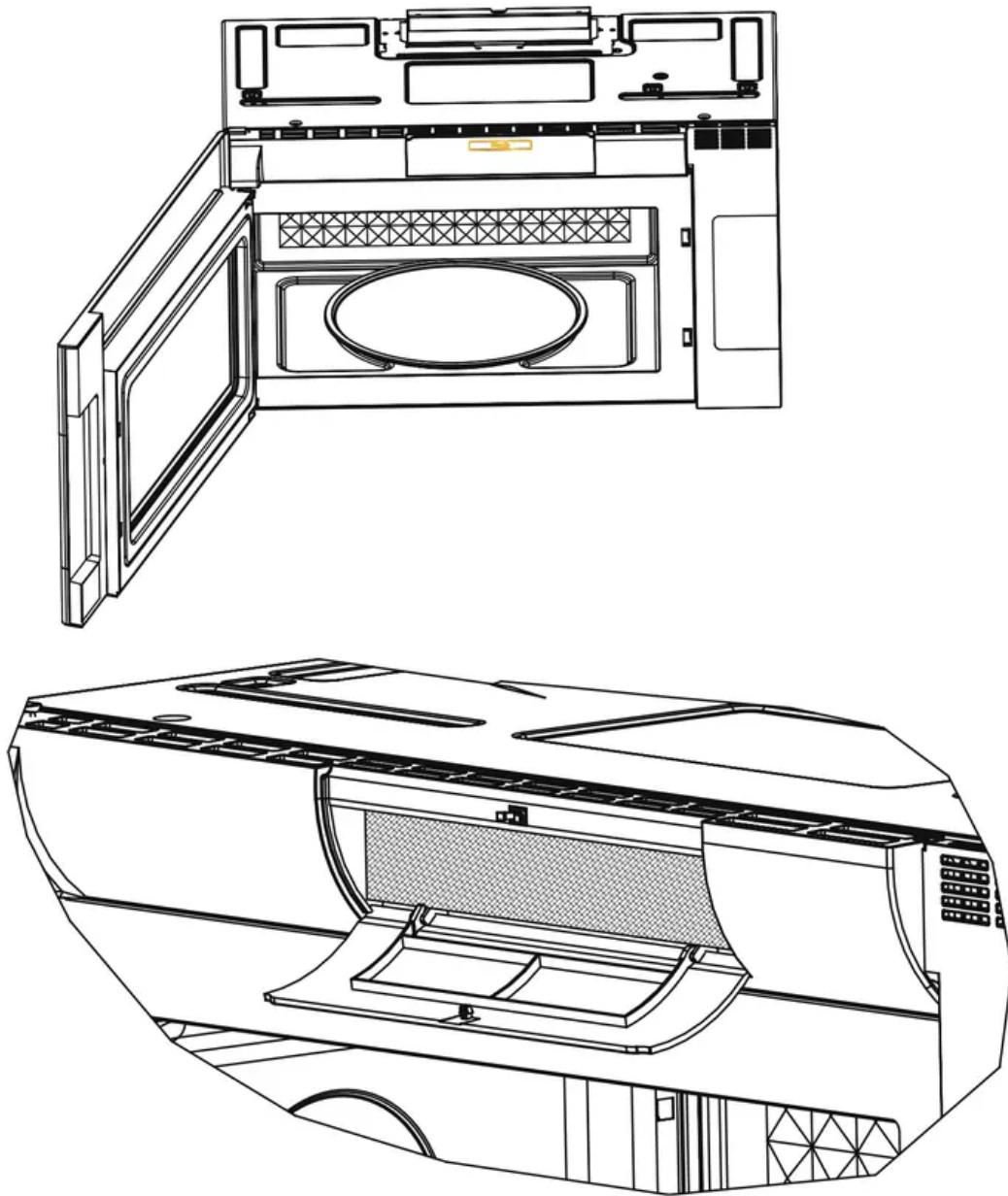

To Install the Charcoal Filter

To install a new charcoal filter, remove plastic and other outer wrapping from the new filter.

Insert the top of the filter up and into the grooves on both sides of the inside of the top opening. Once you have cleared the bottom tab, push the bottom of the filter in until it rests in place vertically behind the tab.

Close the charcoal filter cover at center of the grille by pushing the “Push” area again.

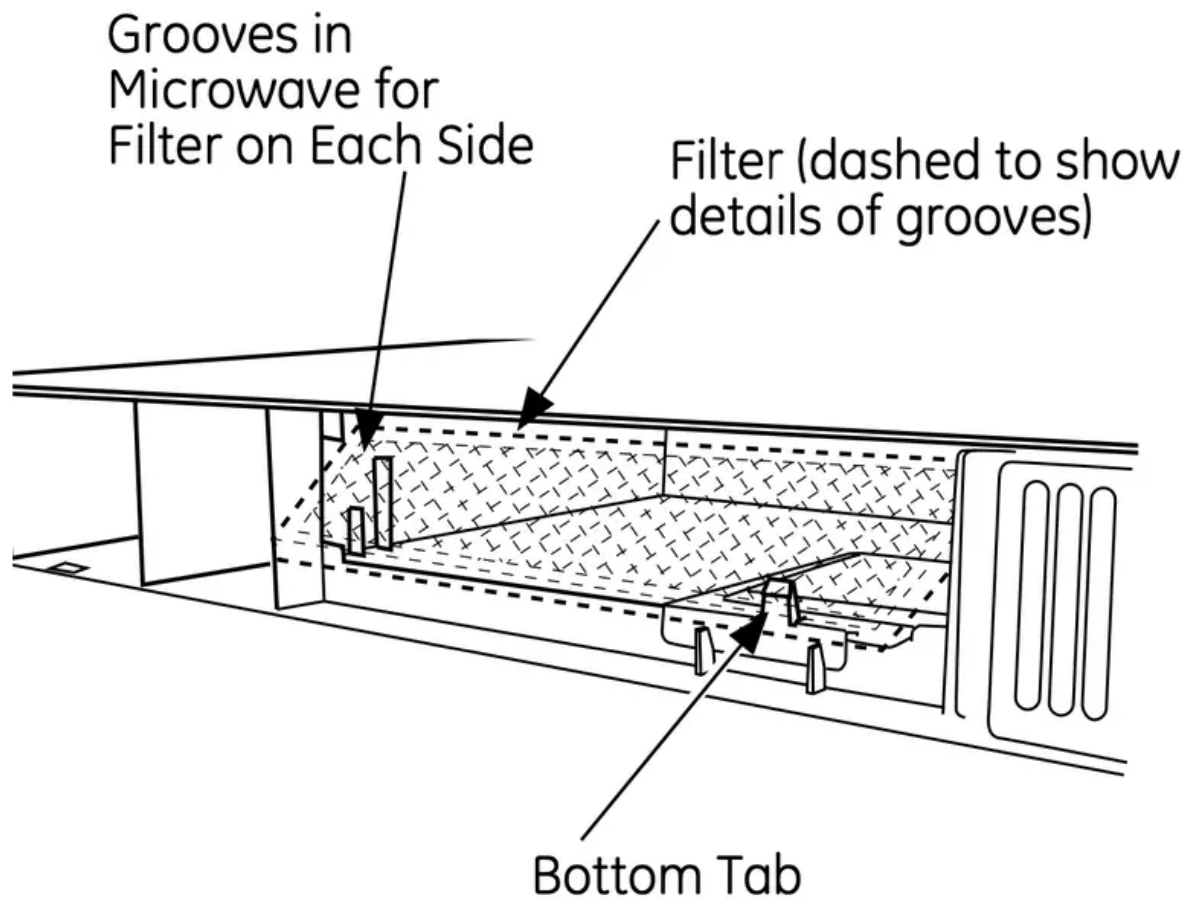

Care and cleaning

Helpful Hints

An occasional thorough wiping with a solution of baking soda and water keeps the inside fresh.

Be sure the power is off before cleaning any part of this microwave oven.



How to Clean the Inside

Walls, Floor, Inside Window, Metal and Plastic Parts on the Door

Some spatters can be removed with a paper towel; others may require a damp cloth. Remove greasy spatters with a sudsy cloth, then rinse with a damp cloth. Do not use abrasive cleaners or sharp utensils on oven walls.

Never use a commercial oven cleaner on any part of your microwave.

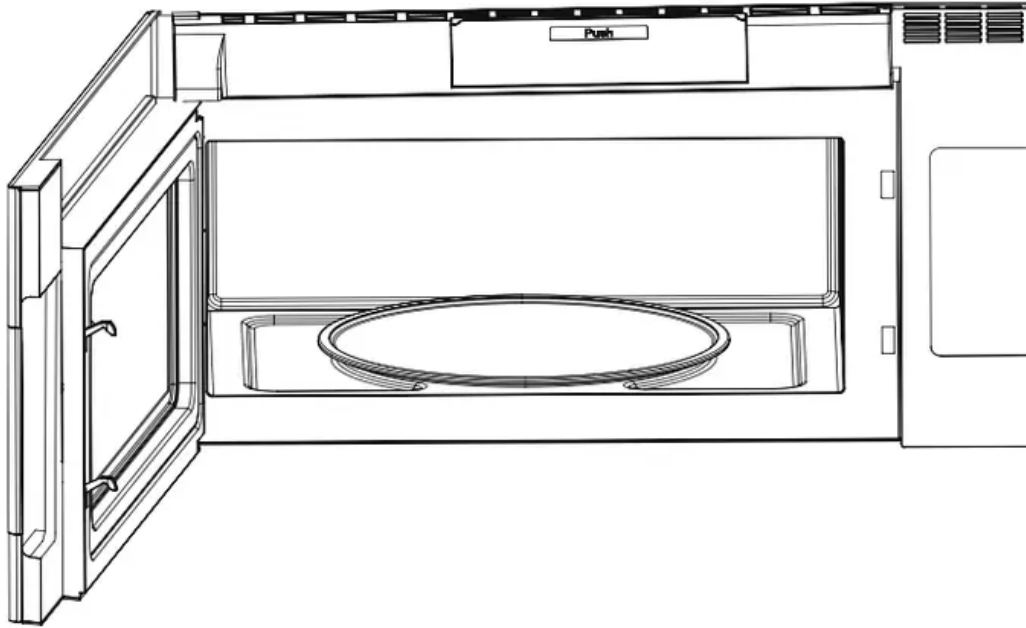

Removable Turntable and Turntable Support

To prevent breakage, do not place the turntable into water just after cooking. Wash it carefully in warm, sudsy water or in the dishwasher. The turntable and support can be broken if dropped. Remember, do not operate the oven in the microwave mode without the turntable and support seated and in place.

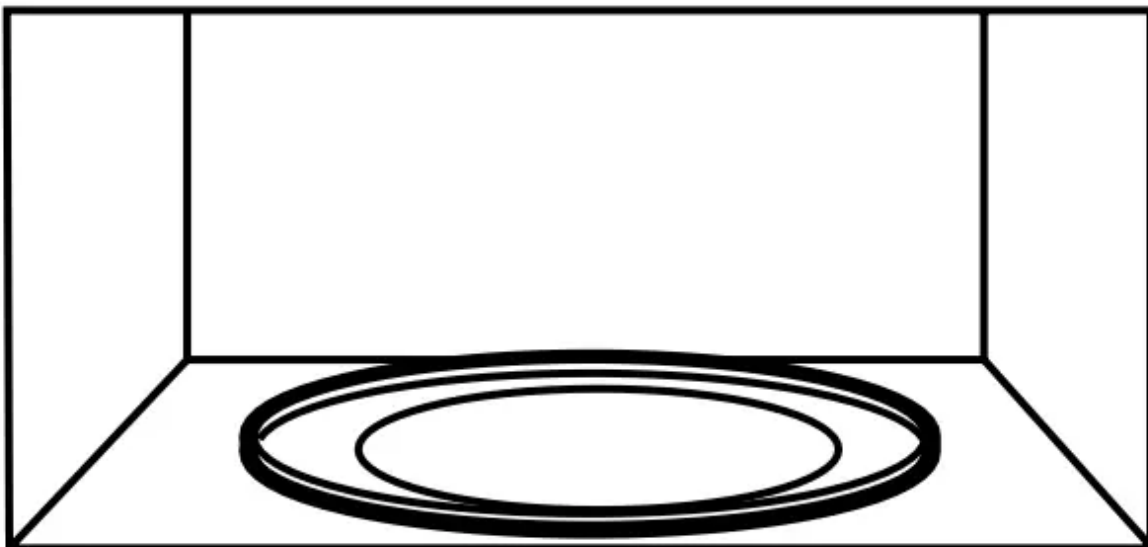

How to Clean the Outside

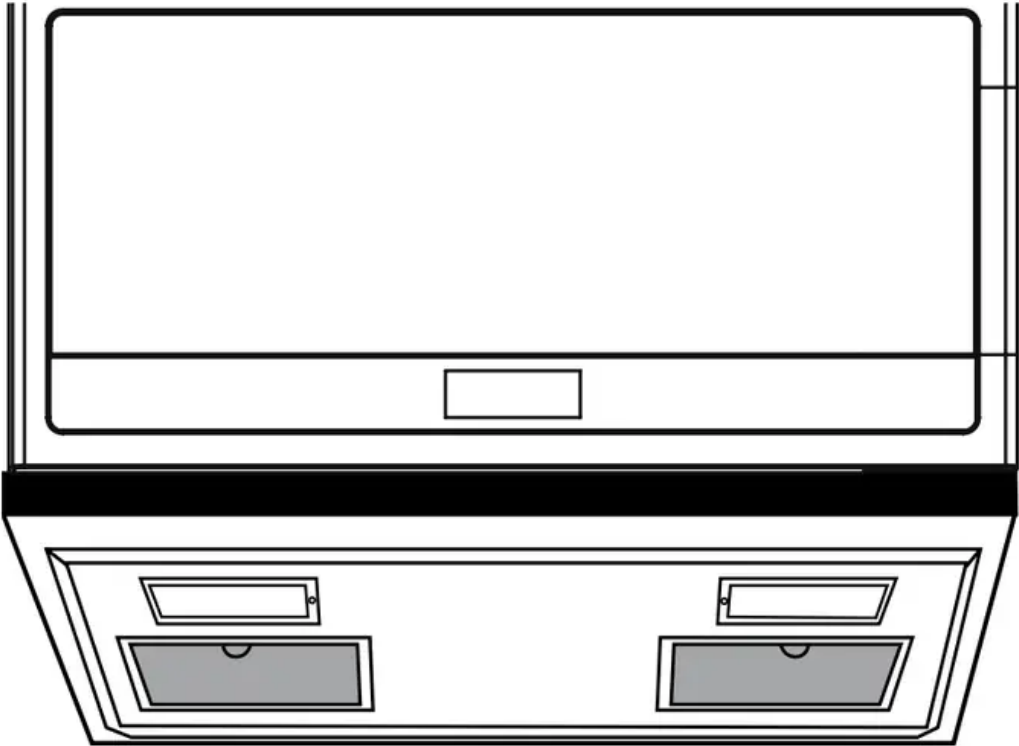
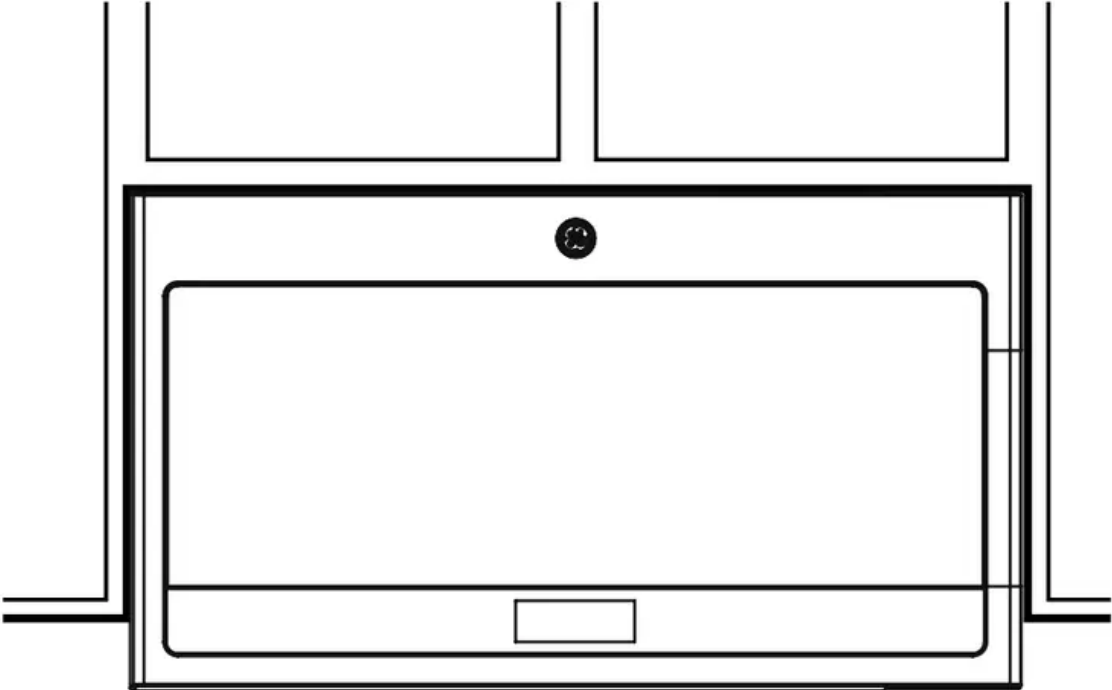

We recommend against the use of spray cleaners and using cleaners with ammonia or alcohol, as they can damage the appearance of the microwave oven. If you choose to use a common household cleaner, first apply the cleaner directly to a clean cloth, then wipe the soiled area.

Case

Clean the outside of the microwave with a sudsy cloth. Rinse and then dry. Wipe the window clean with a damp cloth.

Control Panel

Wipe with a damp cloth. Dry thoroughly. Do not use cleaning sprays, large amounts of soap and water, abrasives or sharp objects on the panel they can damage it. Some paper towels can also scratch the control panel.

Door Panel

Before cleaning the front door panel, make sure you know what type of panel you have. Refer to the eighth digit of the model number. "S" is stainless steel "B", "W" or "C" are plastic colors.

Stainless Steel (on some models)

The stainless steel panel can be cleaned with Stainless Steel Magic or a similar product using a clean, soft cloth. apply stainless cleaner carefully to avoid the surrounding plastic parts. Do not use appliance wax, polish, bleach or products containing chlorine on Stainless Steel finishes.

Plastic Color Panels

Use a clean, soft, lightly dampened cloth, then dry thoroughly.

Door Seal

It's important to keep the area clean where the door seals against the microwave. use only mild, non-abrasive detergents applied with a clean sponge or soft cloth. Rinse well.

Bottom

Clean off the grease and dust on the bottom often. use a solution of warm water and detergent.

Removing and Cleaning the Filters

To remove, slide them to the rear using the tabs. Pull down and out.

To clean the vent filters, soak them and then swish around in hot water and detergent. Don't use ammonia or ammonia products because they will darken the metal. Light brushing can be used to remove embedded dirt.

Rinse, shake and let dry before replacing.

To replace, slide the filters into the frame slots on the back of each opening. Press up and to the front to lock into place.

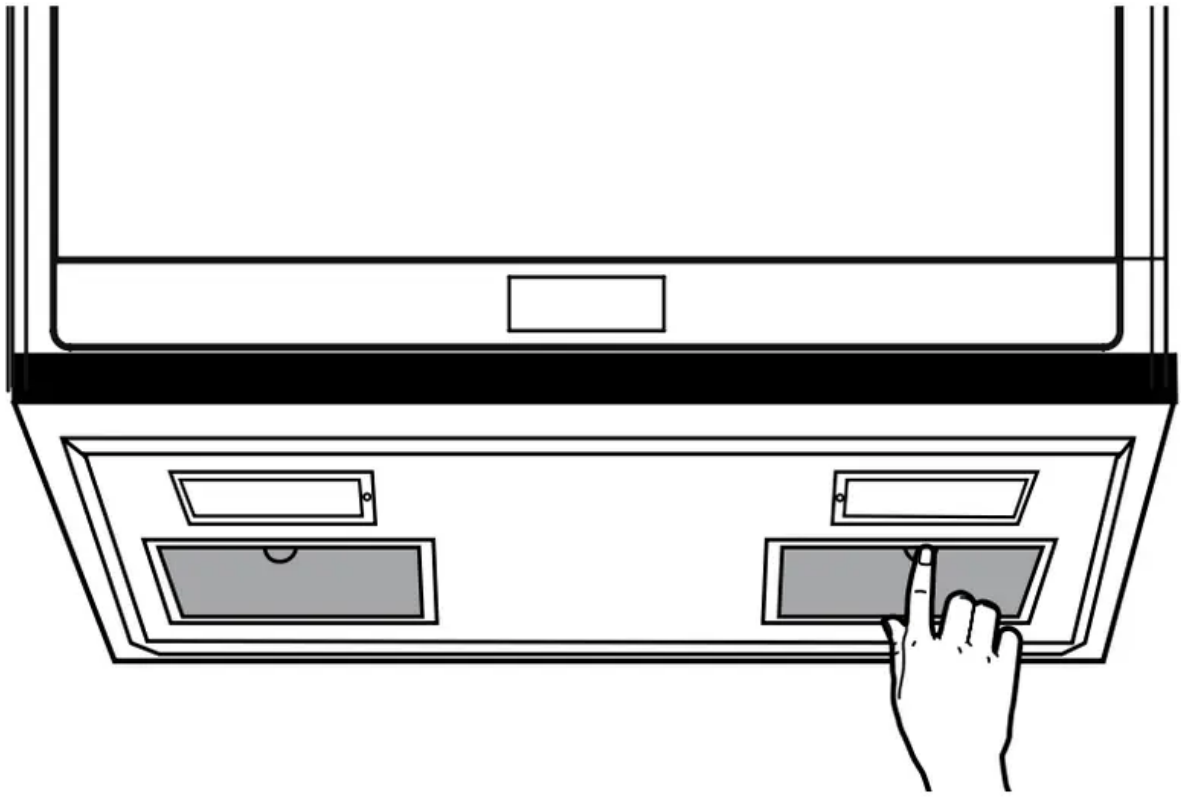

Replacing the light bulb.

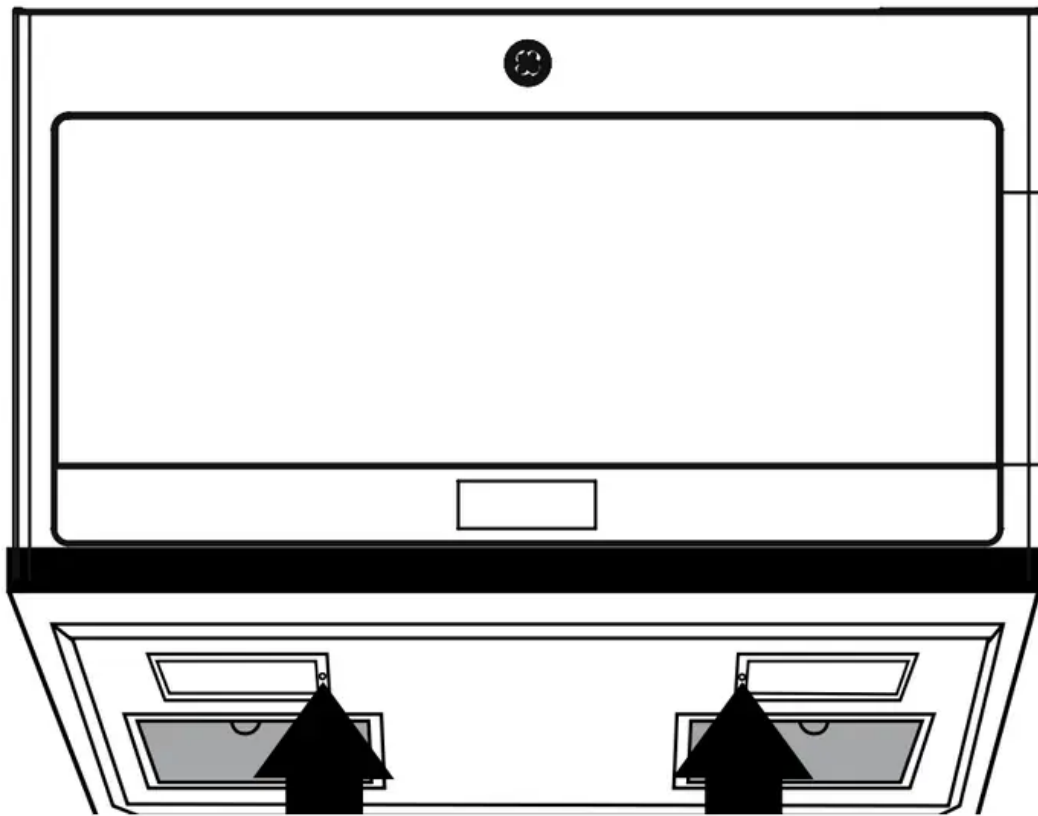

Remove screws.

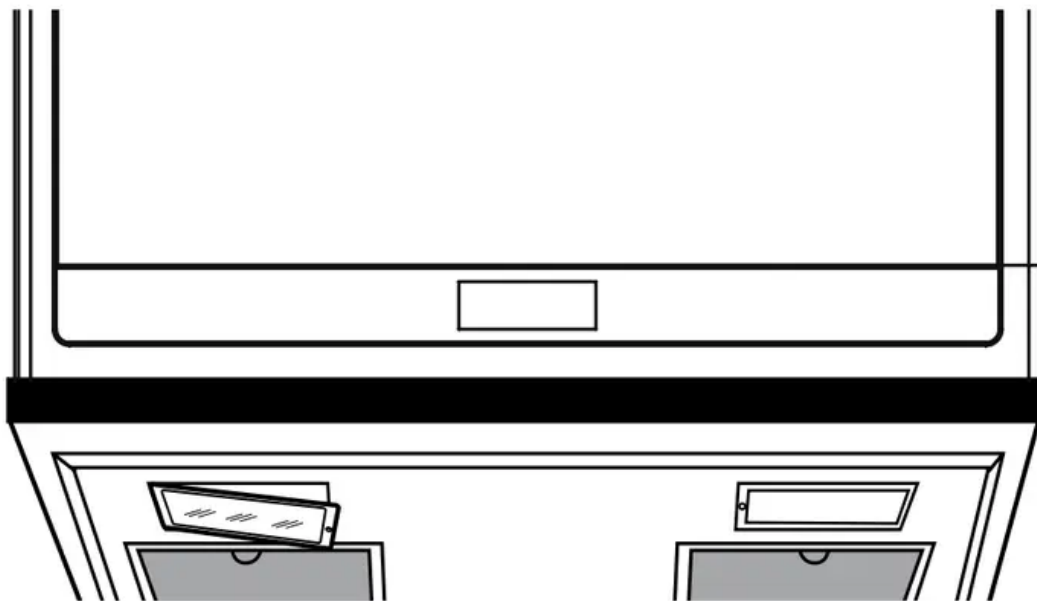

Cooktop Lights/Nite Lights



Replace with 120 volt, 40 watt (max) incandescent bulbs. Order WB25X10030 from your GE supplier.

1. To replace the cooktop lights/nite lights, first disconnect the power at the main fuse or circuit breaker panel, or pull the plug.
2. One side at a time, remove the screw from the side of the light compartment cover and lower the cover until it stops.
3. Be sure the bulb is cool before removing. Break the adhesive seal by gently unscrewing the bulb.
4. Screw in the new bulb, then raise the light cover and replace the screw. Repeat for the other light. Connect electrical power to the oven.

Replacing the Oven Cavity Lamp

1. Disconnect power at the main fuse or circuit breaker panel.
2. Remove the top grill by removing the two screws that hold it in place.
3. Remove charcoal filter if present.
NOTE: Charcoal filter is an optional kit, you may not have one.
4. Press the retainer holding the lamp shield in place.
5. Pull the lamp shield out. unscrew the light bulb out and replace with the 120v-130v, 30W incandescent bulb. Order WB25x10029 from your GE supplier.
6. Return the lamp and lamp shield to original position and replace charcoal filter.
7. Replace the grill and 2 screws. Reconnect power to the oven.

About the exhaust feature.

Charcoal filter (on some models).

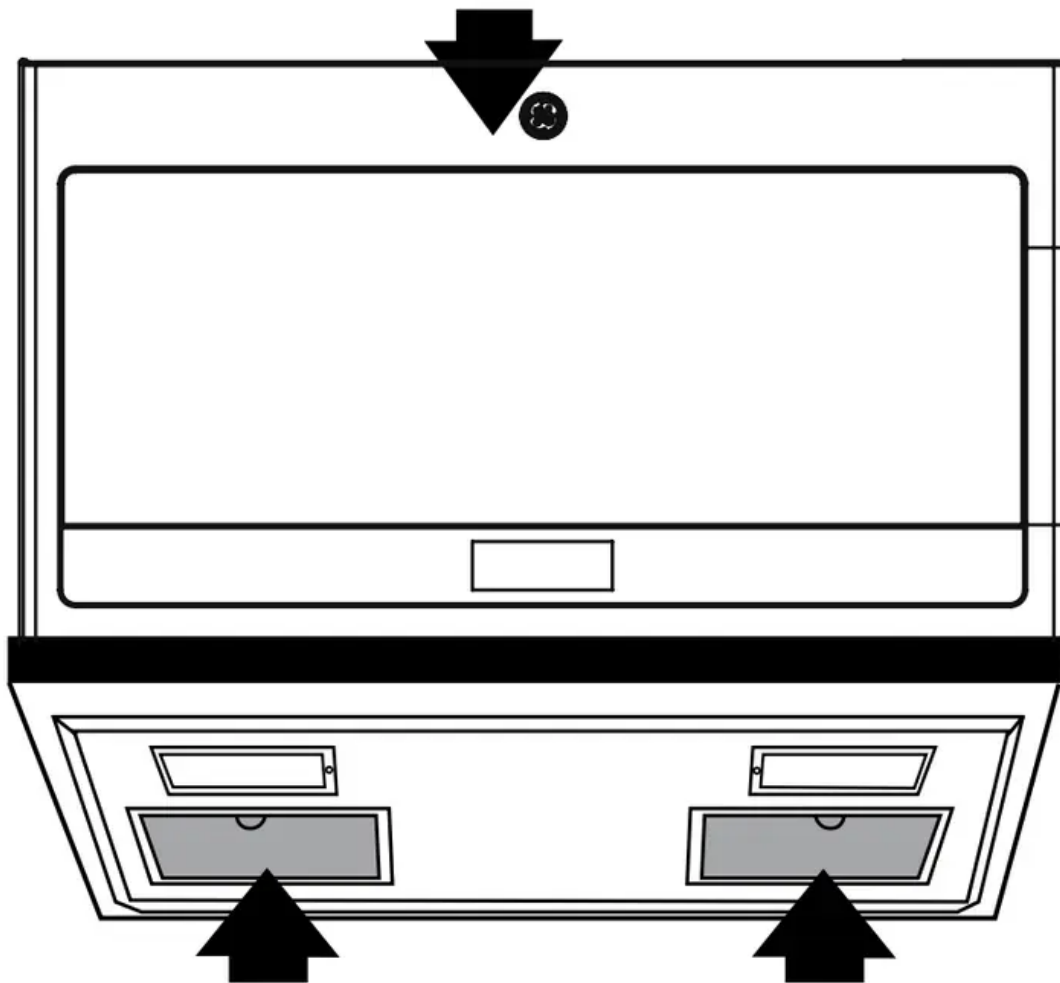

*Reusable vent filters
(on all models).*

Vent Fan

The vent fan has two metal reusable vent filters. Models that recirculate air back into the room also use a charcoal filter.

Reusable Vent Filters

The metal filters trap grease released by foods on the cooktop. They also prevent flames from foods on the cooktop from damaging the inside of the oven.

For this reason, the filters must always be in place when the hood is used. The vent filters should be cleaned once a month, or as needed.



Troubleshooting



Problem	Possible Cause	What To Do
Oven will not start	A fuse in your home may be blown or the circuit breaker tripped.	<ul style="list-style-type: none"> • Replace fuse or reset circuit breaker.
	Power surge.	<ul style="list-style-type: none"> • Unplug the microwave oven, then plug it back in.
	Plug not fully inserted into wall outlet	<ul style="list-style-type: none"> • Make sure the 3-prong plug on the oven is fully inserted into wall outlet.
	Door not securely closed.	<ul style="list-style-type: none"> • Open the door and close securely.
Control panel lighted, yet oven will not start	Door not securely closed.	<ul style="list-style-type: none"> • Open the door and close securely.
	START/PAUSE button not pressed after entering cooking selection.	<ul style="list-style-type: none"> • Press START/PAUSE.
	Another selection entered already in oven and CANCEL/ OFF button not pressed to cancel it.	<ul style="list-style-type: none"> • Press CANCEL/OFF.
	Cooking time not entered after pressing COOK TIME	<ul style="list-style-type: none"> • Make sure you have entered cooking time after pressing COOK TIME.
	CANCEL/OFF was pressed accidentally.	<ul style="list-style-type: none"> • Reset cooking program and press START/PAUSE.
	The control has been locked.	<ul style="list-style-type: none"> • Press and hold CANCEL/OFF for about 3 seconds to unlock the control.

Problem	Possible Cause	What To Do
CONTROL LOCKED appears on display		
Floor of the oven is warm even when the oven has not been used	The cooktop light is located below the oven floor. When light is on, the heat it produces may make the oven floor get warm.	<ul style="list-style-type: none"> • This is normal.
You hear an unusual low-tone beep	You have tried to change the power level when it is not allowed	<ul style="list-style-type: none"> • Many of the oven's features are preset and cannot be changed.
Vent fan comes on automatically	The vent fan automatically turns on to protect the microwave if it senses too much heat rising from the cooktop below.	<ul style="list-style-type: none"> • This is normal.
Bluetooth connection not paired	Power interruption may disrupt bluetooth connection.	<ul style="list-style-type: none"> • Try to reconnect by initiating the CHEF CONNECT process on the gE Range, then holding the CHEF CONnECT button for 3 seconds on the microwave. This will restart the pairing process. if this does not work, unplug unit or reset the circuit breaker to reset the control.

Warning

This content is compiled from multiple sources and is provided for reference purposes only. It may not be complete or fully applicable to all situations. If you are unable to resolve your issue, please contact the product manufacturer or an authorized service provider for official support.

