

## Installation

### PREPARING FOR INSTALLATION

#### Ventilation Air From Inside Building

This fresh air would come from adjoining unconfined space. When ventilating to an adjoining unconfined space, you must provide two permanent openings: one within 12 in. of the wall connecting the two spaces (see options 1 and 2, Fig. 1). You can also remove door into adjoining room (see option 3, Fig. 1). Follow the National Fuel Gas Code NFPA 54/ANS Z223.1. Air for Combustion and Ventilation for required size of ventilation grills or ducts.

Fig. 1 - Ventilation Air from Inside Building

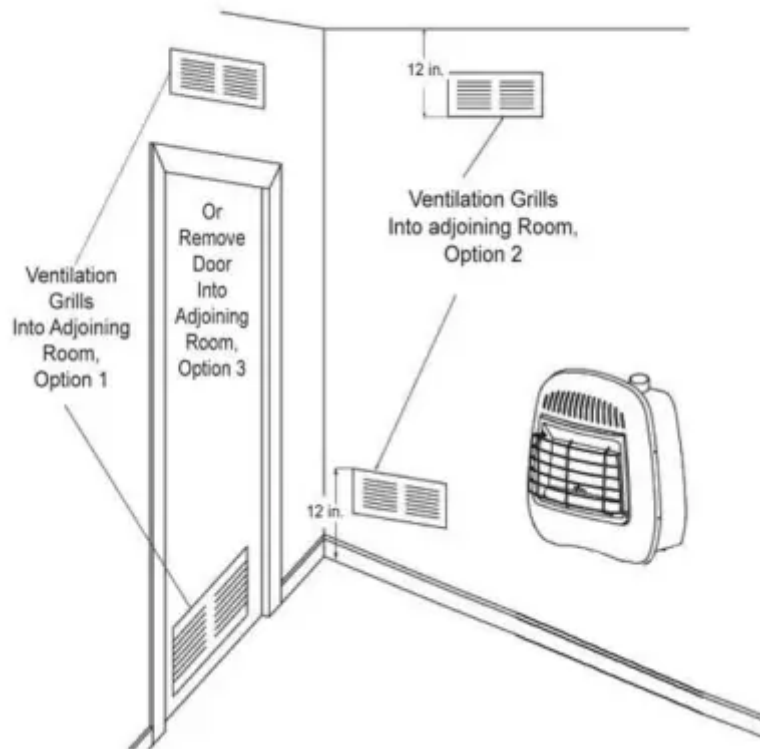

#### Ventilation Air From Outdoors

Provide extra fresh air by using ventilation grills or duct. You must provide two permanent openings: one within 12 in. of the ceiling and one within 12 in. of the floor. Connect these items directly to the outdoors or spaces open to the outdoors. These spaces include attics and crawl spaces. Follow the National Fuel Gas Code NFPA 54/ANS Z223.1. Air for Combustion and Ventilation for required size of ventilation grills or ducts.

Fig. 2 - Ventilation Air from Outdoors

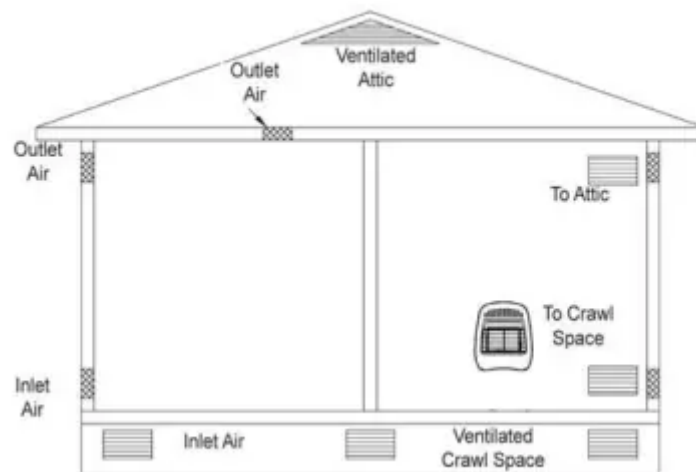

**IMPORTANT:** Do not provide openings for inlet or outlet air into attic if attic has a thermostat-controlled power vent. Heated air entering the attic will activate the power vent. Rework worksheet, adding the space of the adjoining unconfined space. The combined spaces must have enough fresh air to supply all appliances in both spaces.

**NOTICE:** This heater is intended for use as supplemental heat. Use this heater along with your primary heating system. Do not install this heater as your primary heat source.

**WARNING:** A qualified technician must install heater. Follow all local codes.

**WARNING:** Maintain the minimum clearances. If possible, provide greater clearances from the floor, ceiling, and adjoining wall than required.

**CAUTION:** This heater creates warm air currents. These currents move heat to wall surfaces next to heater. Installing heater next to vinyl or cloth wall coverings or operating heater where impurities (such as tobacco smoke, candles, cleaning fluids, oil or kerosene lamps, etc.) in the air exist, may cause walls to discolor.

### CLEARANCES TO COMBUSTIBLES

Carefully follow the instructions below. This heater can be mounted on the wall or on the floor using the support legs (Select Models).

**WARNING:** Maintain the minimum clearances shown in (See Fig. 3). If you can, provide greater clearances from floor, ceiling, and joining wall.

Fig. 3 - Mounting clearances as viewed from front of heater (inches)

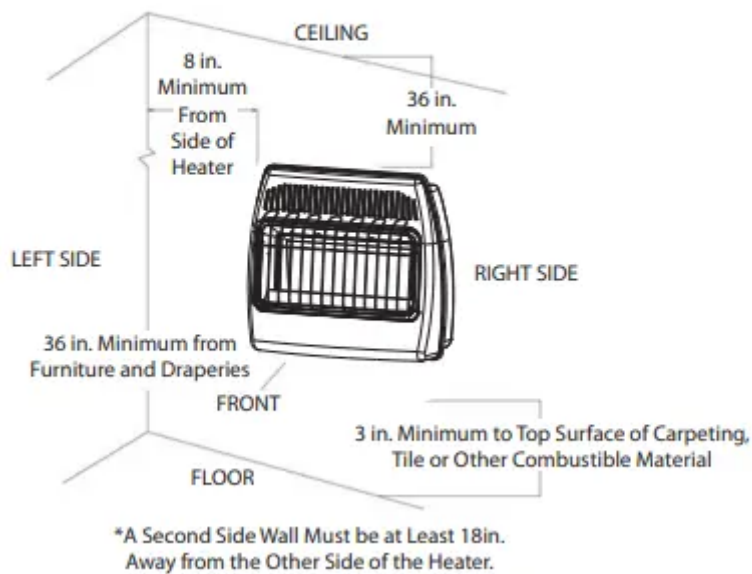

MINIMUM CLEARANCE TO COMBUSTIBLES				
*LEFT / RIGHT	TOP	BOTTOM	FRONT	Rear
8 in.	36 in.	3 in.	36 in.	0 in. to Spacer
Top clearance is from top of heater to ceiling, wood shelf or other combustible material				
Bottom clearance is from bottom of heater to surface of carpet, tile or other combustible material.				

- \*A second side wall must be at least 18 in. away from the other side of the heater. Always maintain a minimum of 36 in. clearance from furniture and draperies.
- \*For the installation in residential garages please refer to the bottom of page 3.

### INSTALLING IGNITOR BATTERY

- Battery is included.
- Unscrew ignitor cap and insert included battery negative (flat) side down (See Fig. 7). Replace Ignitor cap.

Fig. 7 - Installing Ignitor Battery

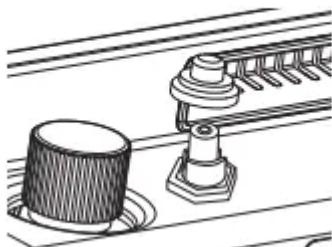

- Be sure to observe proper polarity (+/-) when installing or re- placing the battery. Damage due to improper battery installa- tion may void the warranty on the product.
- Install/replace the battery according to the type and quantity stated in table below.

- Remove battery when depleted.
- For long periods of non-operation, remove the battery from all components for safety.

**WARNING:** Do not use rechargeable silver oxide cell batteries.

Component	Type of Battery	Battery Qty.
Ignitor	AAA	1

Do NOT dispose of batteries in fire. Improper disposal may cause batteries to leak or explode.

### INSTALLING FAN (OPTIONAL)

**WARNING:** Electrical Grounding Instructions This appliance is equipped with a three-prong (grounding) plug for your protection against shock hazard and should be plugged directly into a properly grounded three-prong receptacle (See Fig. 8).

Fig. 8 - Fan Electric Supply

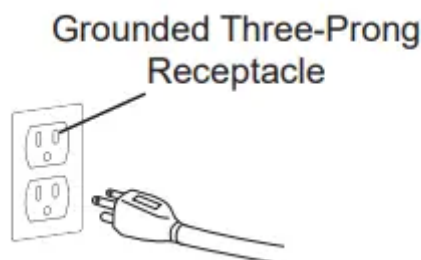

1. Wall mounted heater must be disconnected from gas supply and removed from wall before installing fan accessory. Contact a qualified service person to do this.
2. Remove fan knock-out panel using a screwdriver (See Fig. 9). Attach Fan to the rear panel of the heater using the four screws provided.

Fig. 9 - Knock-out Panel



NOTE: Be sure the rocker switch is positioned in the upper right corner. (See Fig. 10).

Fig. 10 - Attaching Fan

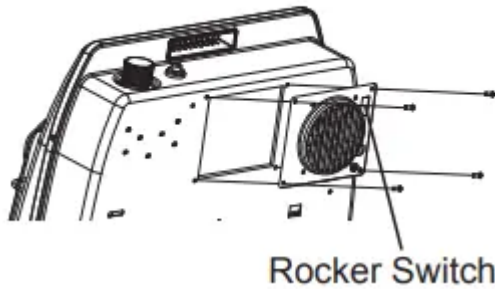

3. This fan is equipped with manual "MAN" and automatic "AUTO" settings (See Fig. 11 on page 13). Set the rocker switch to "MAN" for manual mode, allowing the fan to continuously run until the rocker switch is returned to the OFF "O" position. Set the rocker switch to "AUTO" for the automatic mode, which will turn the fan on and off based on ambient room temperature. It may take 5 to 10 minutes for the fan to come on when the unit is cold.

Fig. 11 - Operating Fan



NOTE: If any of the original wire as supplied with the appliance must be replaced, it must be replaced with a wire of at least an equal temperature rating. Refer to Fig. 12 on page

Fig. 12- Fan Wiring Diagram

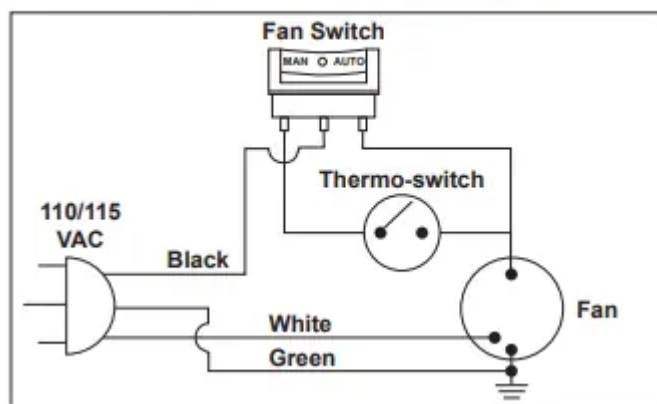

13 for wiring diagram.

**CAUTION:** Label all wires prior to disconnection when servicing controls. Wiring errors can cause improper and dangerous operation. Verify proper operation after servicing.



## LOCATING HEATER

This heater is designed to be mounted on a wall or on a floor, using the Support Legs (Select Models) included with select models.

For convenience and efficiency, install heater:

1. Where there is easy access for operation, inspection, and service.
2. In the coldest part of room.
3. A minimum of 3' away from furniture and draperies.

## FLOOR MOUNTING (Select Models) (Cannot be done in bedroom or bathroom) (Cannot be used for garage and ice-house heaters)

**NOTE:** This is an optional accessory and is not required for operation of the heater.

Before installing Support Legs to heater base, please make sure you have the following items: (2) Support Legs (4) Support Leg Screws (M4\*15)

1. Set down a blanket onto the table where the heater will be placed for leg installation to prevent scratching of the table and/or the heater.
2. Set back of heater on table with the bottom of heater extending outside the table edge.
3. Fasten Support Legs to heater using Support Leg Screws (Fig.13)

Fig. 13 - Attaching Legs

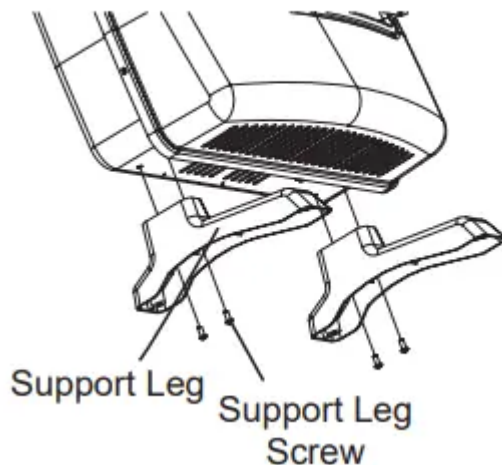

Note: If the heater is to be installed directly on carpeting, tile or other combustible material, other than wood flooring, the appliance shall be installed on a metal or wood panel extending the full width and depth of the appliance.

4. Once positioned, secure heater to the floor using Support Leg Screws (M4\*15) and mounting holes found on heater Support Legs (See

Fig.14).

**Fig. 14 - Securing Support Leg**

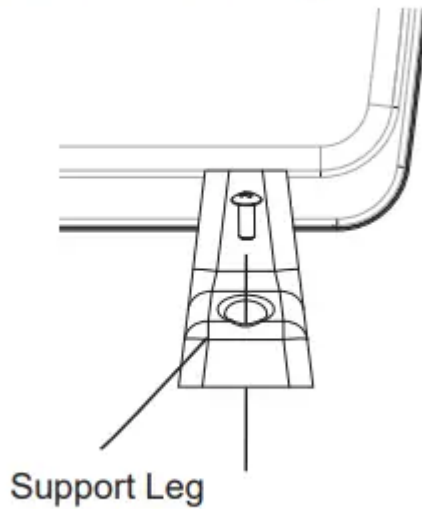

**WALL MOUNTING WARNING:**

Failure to position the parts in accordance with these diagrams or failure to use only parts specifically approved with this heater may result in property damage or personal injury.

**Mounting Bracket**

The mounting bracket is located separately from the unit, but packed inside the same box.

**Methods For Attaching Mounting Bracket To Wall**

<b>⚠ WARNING</b>	
	<b>ELECTRICAL, PLUMBING OR GAS LINES MAY BE IN WALL.</b> Before cutting, drilling or hammering verify their location. If needed, contact your electrician, plumber or service person.

Use only the last hole on each end of mounting bracket to attach bracket to wall. Attach mounting bracket to a wall only in one of two ways:

1. Attaching to wall stud: This method provides the strongest hold. Insert wood screws (ST. 8\*45-16) through mounting bracket and into wall studs.
2. Attaching to expansion bracket: This method allows you to attach mounting bracket to hollow walls (wall areas between studs) or to solid walls (concrete or masonry).

Decide which method better suits your needs. Either method will provide a secure hold for the mounting bracket.



## Marking Screw Locations

1. Tape mounting bracket to wall where heater will be located. Make sure mounting bracket is level.
2. Mark screw locations on wall (See Fig. 16).

Note: Mark only last hole on each end of mounting bracket. Insert (2) wood screws (ST.

Fig. 16 - Mounting Bracket Clearances (inches)

### Series BF10

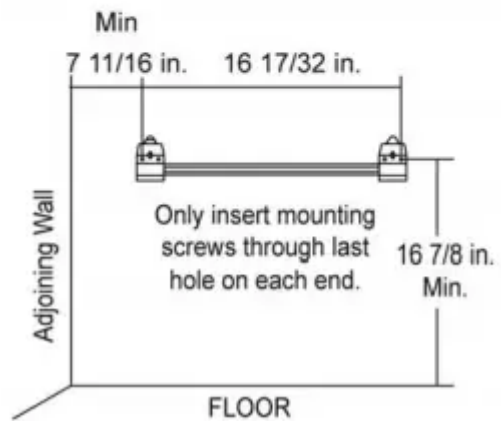

### Series BF20/30

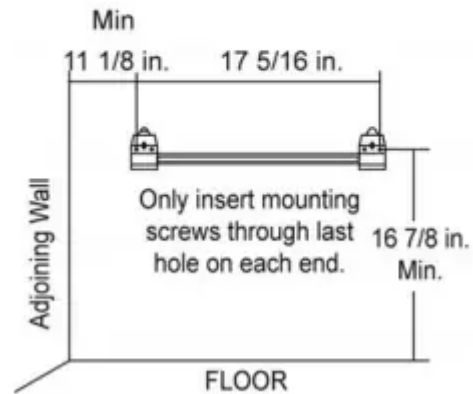

8\*45-16) total through these holes only.

3. Remove tape and mounting bracket from wall.

## Attaching Mounting Bracket To Wall

**Note:** Expansion bracket, wood screws (ST.8\*45-16), and wall hanging spacers are in hardware package. The hardware package is provided with heater.

## Attaching to Wall Stud Method

### For attaching mounting bracket to wall studs:

1. Drill holes at marked locations using 9/64-inch drill bit.
2. Place mounting bracket onto wall. Line up last hole on each end of bracket with holes drilled in wall.
3. Insert wood screws (ST.8\*45-16) through bracket and into wall studs.
4. Tighten wood screws (ST.8\*45-16) until mounting bracket is firmly fastened to wall studs.
5. Check that the bracket is secure before mounting heater!

Attaching to Expansion Bracket Method For attaching mounting bracket to hollow walls (wall areas between studs) or solid walls (concrete or masonry):

1. Drill holes at marked locations using 5/16-inch drill bit. For solid walls (concrete or masonry), drill at least 1 inch deep.
2. Fold wall expansion bracket as shown in (See Fig. 17).

Fig. 17 - Folding the Expansion Bracket



3. Insert wall expansion bracket (wings first) into hole. Tap expansion bracket flush to wall.
4. For thin walls (1/2 inch or less), insert expansion bracket tool into expansion bracket. Push expansion bracket tool to “pop” open expansion bracket wings (See Fig. 18).

Fig. 18 - Popping Open Anchor Wing For Thin Walls

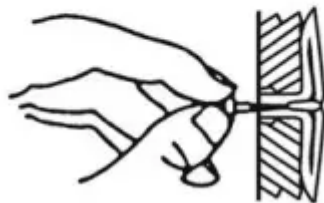

**IMPORTANT:** Do not hammer expansion bracket tool! For thick walls (over 1/2 inch thick) or solid walls, do not pop open wings.

5. Place mounting bracket onto wall. Line up last hole on each end of bracket with expansion bracket.
6. Insert expansion bracket screws (ST4.8\*15-16) through wall mounting bracket and into expansion brackets.

7. Tighten expansion bracket screws (ST4.8\*15-16) until mounting bracket is firmly fastened to wall.
8. Check that the bracket is secure before mounting heater!

### Attaching Wall Hanging Spacers to Heater

**WARNING:** Failure to properly install the wall hanging spacers may result in property damage, personal injury or even death.

1. Locate spacer mounting holes on the lower right/left sections of the heater back panel.
2. Secure (2) wall hanging spacers to heater back panel using (2) wall hanging spacer

Fig. 19a - Attaching Wall Hanging Spacers to Heater

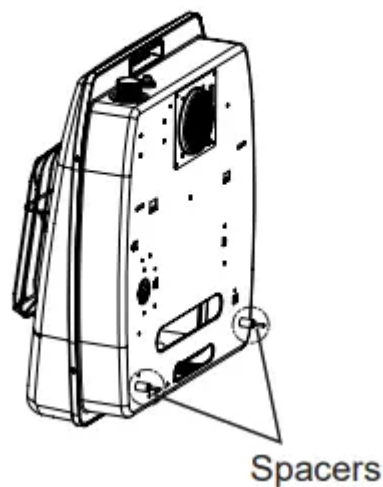

screws (M4\*25) (See Fig. 19a).

### Placing Heater On Mounting Bracket

1. Locate two horizontal slots on back panel of heater.
2. Place heater onto mounting bracket. Slide horizontal slots onto stand-out tabs on mounting bracket. Be sure spacers rest evenly against wall (See Fig. 19b).

Fig. 19b - Mounting Heater  
Onto Mounting Bracket

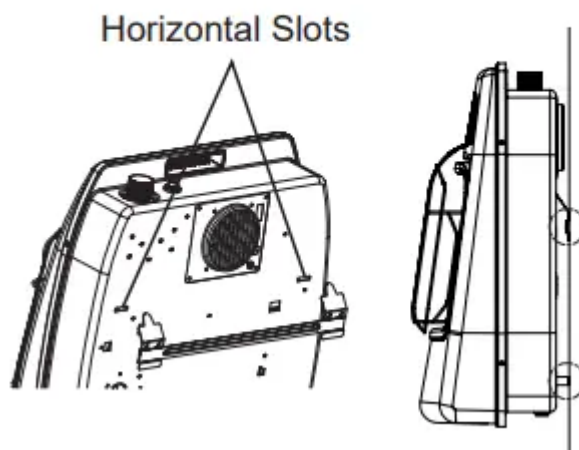

## CONNECTING TO GAS SUPPLY

**WARNING:** A qualified service technician must connect heater to gas supply. Follow all local codes.

**IMPORTANT:** This appliance requires a 3/8-inch NPT (National Pipe Thread) inlet connection to the pressure regulator. Never connect the heater to private (non-utility) gas wells, commonly known as wellhead gas.

**WARNING:** Do not overtighten gas connections.

**CAUTION:** Use only new, black iron or steel pipe. Internally tinned copper tubing may be used in certain areas. Check your local codes. Use pipe of 1/2-in. diameter or greater to allow proper gas volume to heater. If pipe is too small, undue loss of pressure will occur.

**CAUTION:** Check your gas line pressure before connecting heater to gas line. Gas line pressure must be a minimum 6" WC for NG & 11" WC for LP with a max pressure of 9" WC for NG & 14" WC for LP. If gas line pressure is higher, the unit will not work and heater regulator damage could occur.

**CAUTION:** Never connect heater directly to an LP supply. This heater requires an external regulator (not supplied). Install the external regulator between the heater and gas supply.

**CAUTION:** Avoid damage to regulator. Hold gas regulator with wrench when connecting into gas piping and/or fittings.

**CAUTION:** Use pipe joint sealant that is resistant to gas (Propane or Natural Gas).

### Typical Inlet Pipe Diameters

Use 3/8-inch black iron pipe or greater. Installation must include an equipment shutoff valve, union, and plugged 1/8-inch NPT tap. Locate NPT tap within reach for test gauge hook up. NPT tap must be upstream from heater (see Fig. 20).

**IMPORTANT:** Install an equipment shutoff valve in an accessible location. The equipment shutoff valve is for turning on or shutting off the gas to the appliance.

Apply pipe joint sealant lightly to male threads. This will prevent excess sealant from going into pipe. Excess sealant in pipe could result in clogged heater valves.

Install sediment trap in supply line as shown (See Fig. 20). Place sediment trap where it is within reach for cleaning. Place sediment trap where trapped matter is not likely to freeze. A sediment trap traps moisture and contaminants. This keeps them from going into heater controls. If sediment trap is not installed or is installed wrong, heater may not run properly

Fig. 20 - Gas Connection

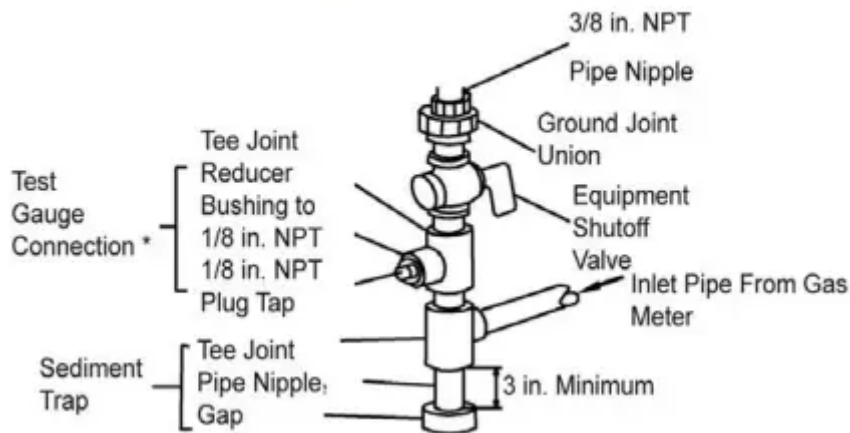

### CHECKING GAS CONNECTIONS

**WARNING:** Test all gas piping and connections for leaks after installing or servicing. Correct all leaks immediately.

**WARNING:** Never use an open flame to check for a leak. Apply a 50/50 mixture of liquid soap and water to all joints. If bubbles form, there may be a leak. Correct all leaks immediately.

### Pressure Testing Gas Supply Piping System Test Pressures In Excess Of 1/2 PSIG ( 3.5kPa )

The appliance and its appliance main gas valve must be disconnected from the gas supply piping system during any pressure testing of that system at test pressures in excess of 1/2 psi (3.5 kPa).

### Pressure Testing Gas Supply Equal To or less than 1/2 PSIG ( 3.5kPa )

The appliance must be isolated from the gas supply piping system by closing its equipment shut-off valve during any pressure testing of the gas supply piping system at test pressures equal to or less than 1/2 psi (3.5 kPa).

### Leak Testing Heater Gas Internal Connections

1. Open equipment shutoff valve (See Fig. 21).

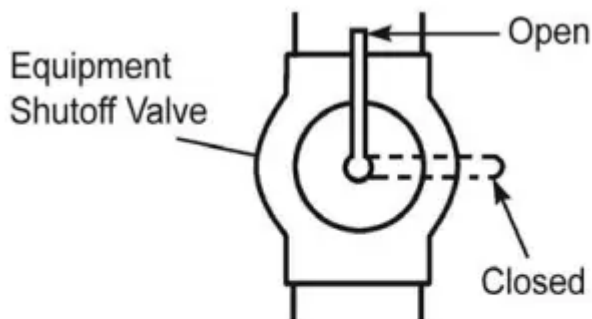

Fig. 21 - Equipment Shut -off Valve



2. Make sure control knob of heater is in the OFF position.
3. Open gas supply tank valve (LP systems).
4. Check all joints from equipment shutoff valve to control valve. Apply 50/50 mixture of liquid soap and water to gas joints. If bubbles form, there may be a leak.
5. Light heater (see Operation, page 18). Check all other internal joints for leaks.
6. Turn off heater (see "To Turn Off Gas to Appliance," page 19).

## PRODUCT FEATURES

### SAFETY PILOT

This heater has a pilot with an Oxygen Depletion Sensing (ODS) safety shutoff system. The ODS/ pilot shuts off the heater if there is not enough fresh air and cuts off main burner gas in the event of flame out.

### LEG KIT (SELECT MODELS)

2 support legs and 4 support leg screws are included for floor mounting the heater. See page 13.

NOTE: This is an optional accessory and is not required for operation of the heater.

### ELECTRONIC PUSH BUTTON IGNITION SYSTEM

This heater is equipped with an electronic push button ignition system. This system requires one AAA battery (provided).

### THERMOSTAT HEAT CONTROL (SELECT MODELS)

The control automatically cycles the burner on and off to maintain a desired room temperature. See page 24.

### FAN KIT (SELECT MODELS)

The fan kit helps to distribute the warmed air into the space more rapidly. NOTE: This is an optional accessory and is not required for operation of the heater.

**State of Massachusetts:** The installation must be made by a licensed plumber or gas fitter in the Commonwealth of Massachusetts. Sellers of unvented propane or natural gas-fired supplemental room heaters shall provide to each purchaser a copy of 527 CMR 30 upon sale of the unit.

In the State of Massachusetts, unvented propane or natural gas-fired space heaters shall be prohibited in bedrooms and bathrooms.

In the State of Massachusetts the gas cock must be a T-handle type. The State of Massachusetts requires that a flexible appliance connector cannot exceed three feet in length.

## OPERATION

**WARNING:** If you do not follow these instructions exactly, a fire or explosion may result causing property damage, personal injury or loss of life.

A. This appliance has a pilot which must be lighted using the Ignitor. When lighting the pilot, follow these instructions exactly.

B. BEFORE LIGHTING smell all around the appliance area for gas. Be sure to smell next to the floor because some gas is heavier than air and will settle on the floor.

### WHAT TO DO IF YOU SMELL GAS

- Do not try to light any appliance.
- Do not touch any electrical switch; do not use any phone in your building.
- Immediately call your gas supplier from a neighbor's phone. Follow the gas supplier's instructions.
- If you cannot reach your gas supplier, call the fire department.



C. Use only your hand to push in or turn the gas control knob. Never use tools. If the knob will not push in or turn by hand, don't try to repair it, call a qualified service technician. Forced or attempted repair may result in a fire or explosion.

D. Do not use this appliance if any part has been under water. Immediately call a qualified service technician to inspect the appliance and to replace any part of the control system and any gas control, which has been under water.

## LIGHTING INSTRUCTIONS

### MANUAL GAS CONTROL

1. STOP! Read the safety information above on this page.
2. Turn off all electric power to the appliance.
- 3.

Push in gas control knob slightly and turn clockwise  to OFF "  " position.  
(See Fig. 22a)

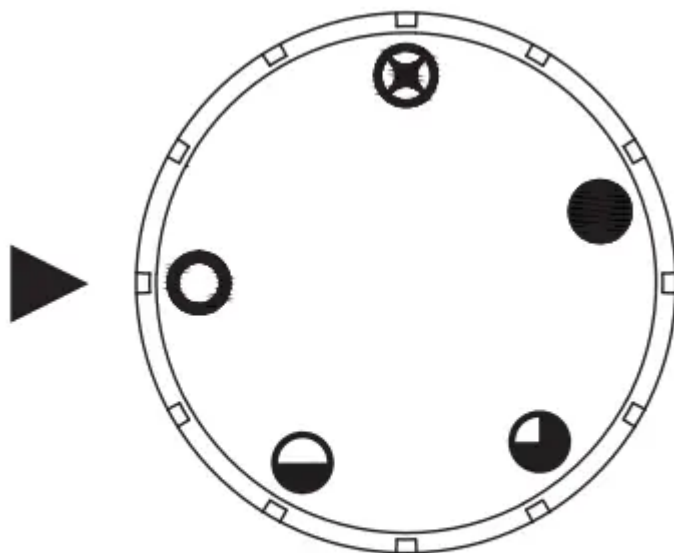



Fig. 22a

NOTE: Knob cannot be turned from PILOT "  " to OFF "  " unless knob is pushed in slightly. Do not force.

4. Wait (5) minutes to clear out any gas. Then smell for gas, including near the floor. If you smell gas, STOP! Follow "B" in the safety information above. If you don't smell gas, go to the next step.

5. Push in gas control knob slightly and turn counterclockwise  to the PILOT

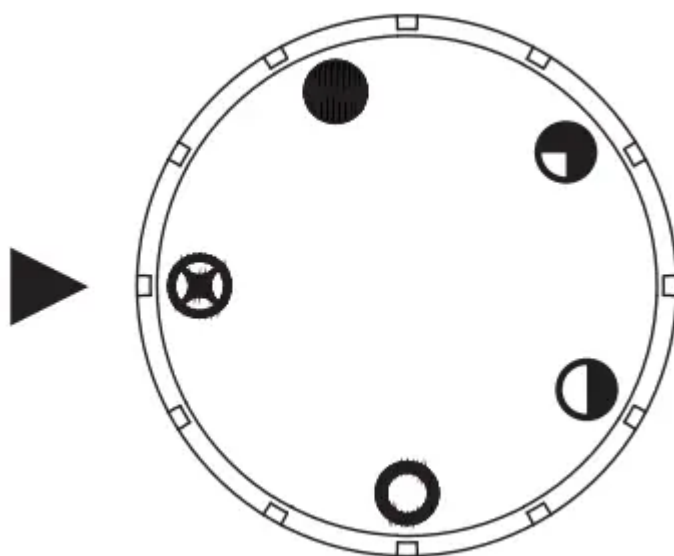

"  " position. (See Fig. 23a) Depress control knob.



6. With control knob depressed, push down on the ignitor button until the pilot lights. The pilot is visible centered below the plaques, behind the front grill. (See Fig. 24)

7. Keep control depressed for (30) seconds after pilot lights. Release control knob.

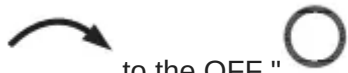
**Note:** If pilot goes out repeat steps 3 through 7. Wait (1) minute before attempting to light pilot again. If after several tries the pilot still goes out, turn the gas control knob clockwise

 to the OFF "  " position and call your service technician or gas supplier.

If the control knob does not pop up when released, stop and immediately and call your service technician or gas supplier.

8. Turn on all electric power to the appliance

9. Turn control knob counter clockwise  to the desired setting.

### THERMOSTAT GAS CONTROL

1. STOP! Read the safety information on the previous page.

2. Turn off all electric power to the appliance.

3. Turn control knob clockwise  to "OFF" position. (See Fig. 22b)

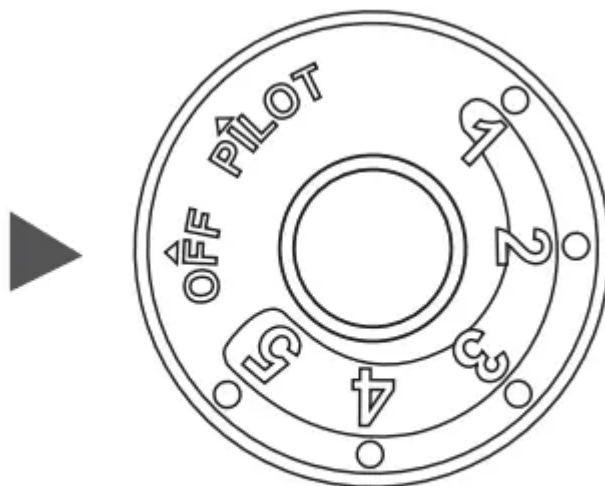



Fig. 22b

4. Wait (5) minutes to clear out any gas. Then smell for gas, including near the floor. If you smell gas, STOP! Follow "B" in the safety information above. If you don't smell gas, go to the next step.

5. Turn knob counterclockwise  to the "PILOT" position. (See Fig. 23b) Depress control knob.

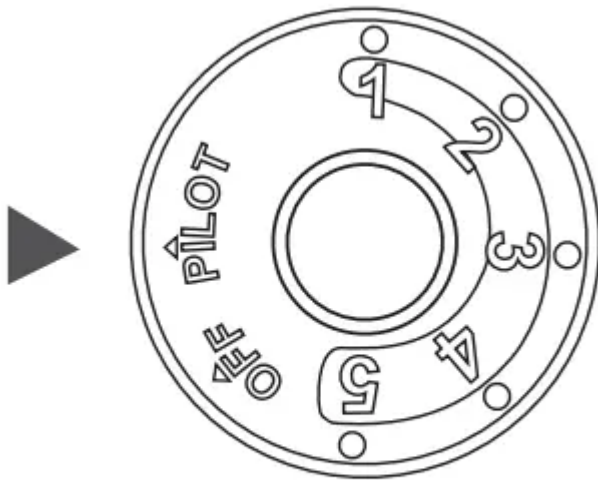

Fig. 23b

6. With control knob depressed, push down on the ignitor button until the pilot lights. The pilot is visible centered below the plaques, behind the front grill. (See Fig. 24)

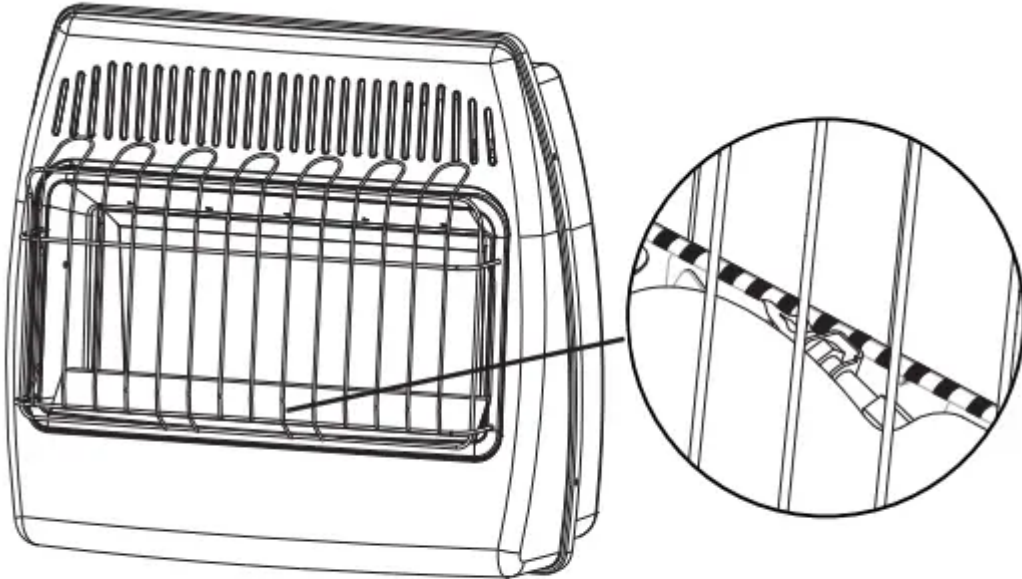



Fig. 24 - Pilot Flame Location

7. Keep control depressed for (30) seconds after pilot lights. Release control knob.  
**Note:** If pilot goes out repeat steps 3 through 7. Wait (1) minute before attempting to light pilot again. If after several tries the pilot still goes out, turn the gas control knob clockwise



 to the "OFF" position and call your service technician or gas supplier. If the control knob does not pop up when released, stop and immediately call your service technician or gas supplier.

8. Turn on all electric power to the appliance.

9. Turn control knob counter clockwise  to desired setting.

## TO TURN OFF GAS TO APPLIANCE

1. Turn off all electric power to the appliance if service is to be performed.

2. Push in gas control knob slightly and turn clockwise  to "OFF" or " " position. DO NOT FORCE.

## THERMOSTATIC CONTROL OPERATION (SELECT MODELS)

The thermostat used on this heater senses the room temperature. At times the room may exceed the set temperature. If so, the burner will shut off. The burner will cycle back on when room temperature drops below the set temperature. The control knob can be set to any comfort level between "HIGH" (5) and "LOW"(1) (See Fig. 25).

## MANUAL CONTROL OPERATION

Manual valves remain burning in the desired setting until manually turned to OFF " "(See Fig. 25).

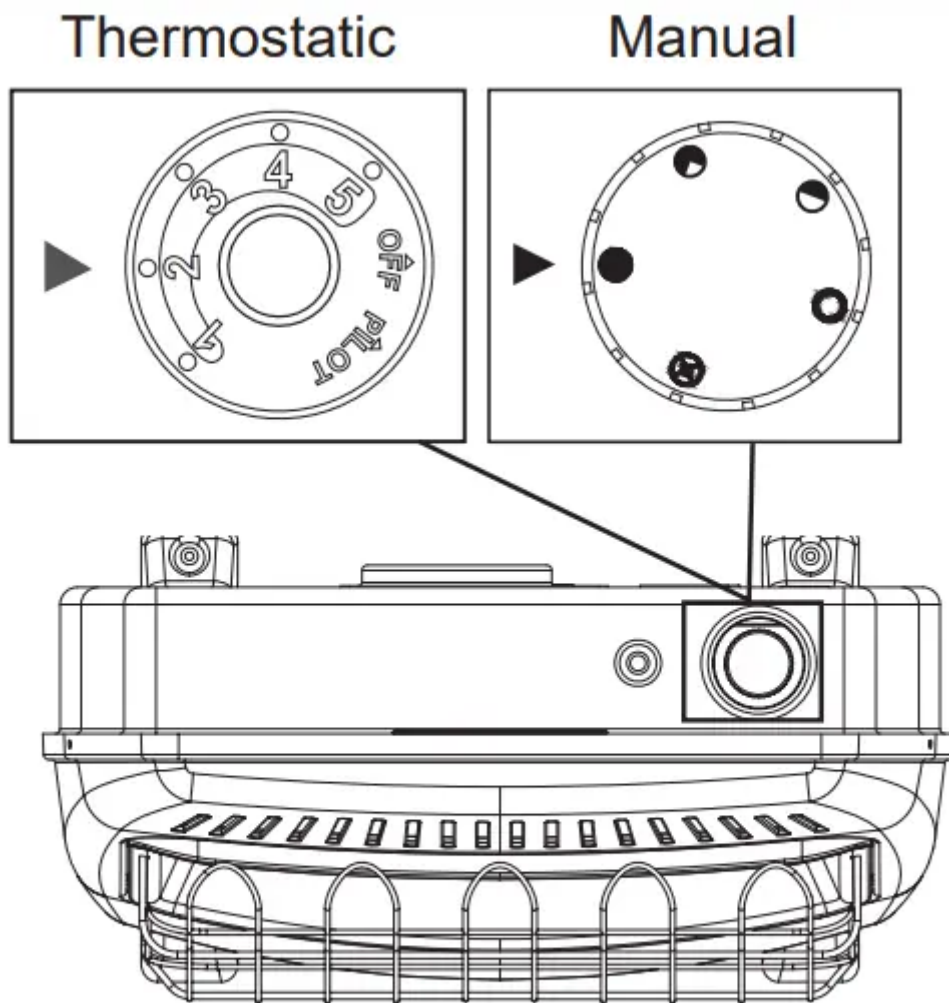

**Fig. 25 - Control Knob Position**

### **INSPECTING BURNERS**

Check pilot flame pattern daily when in use and at least yearly by a qualified service agency.

### **PILOT FLAME PATTERN**

Fig. 26 shows a correct pilot flame pattern. Fig. 27 shows an incorrect pilot flame pattern. The incorrect pilot flame is not touching the thermocouple. This will cause the thermocouple to cool, which shuts the heater off. If pilot flame pattern is incorrect:

- turn heater off (see “To Turn Off Gas to Appliance” on page 19)
- see Troubleshooting pages 23 through 26.

Fig. 26 - Correct Pilot Flame Pattern

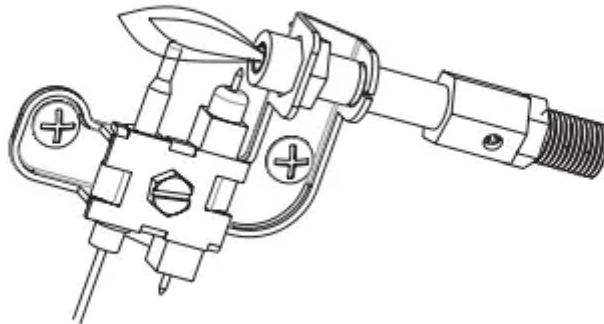
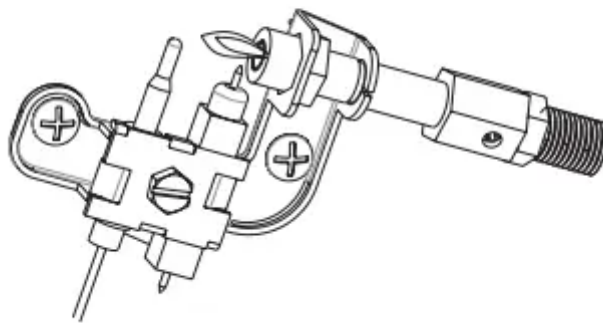

Fig. 27 - Incorrect Pilot Flame Pattern



### BURNER FLAME PATTERN

Fig. 28 shows a correct burner flame pattern. Fig. 29 shows an incorrect burner flame pattern with lifting, and excessive flame height. If burner flame is incorrect:

- turn heater off (see “To Turn Off Gas to Appliance”, page 20).
- see Troubleshooting, pages 23 through 26.

Fig. 28 - Correct/Normal Flame Pattern with short flames with Control Knob Set to High Flame (5)

Fig. 29 - Incorrect/Abnormal Flame Pattern with tall flames with Control Knob Set to High Flame (5)

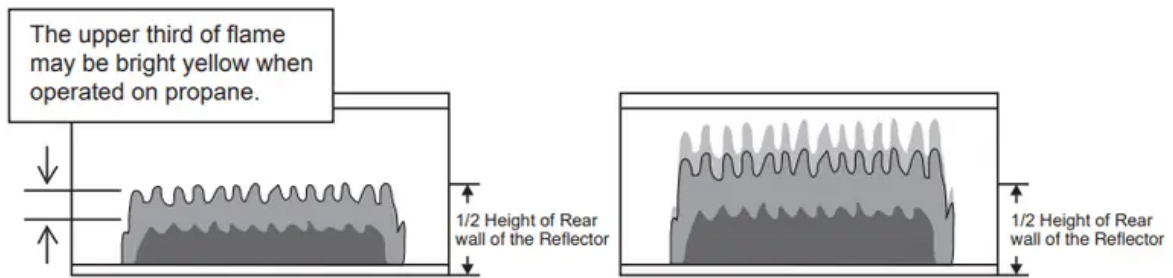

**NOTE:** Ambient flame burners produce both a blue and yellow flame. An excessively high yellow colored flame may be caused by airborne dust, dander, pet hair, etc. Additionally, an excess amount of Mercaptane in the fuel can result in an orange or yellow colored flame.

When this heater is set for use on propane gas, the upper one third of the flame may be bright yellow. When this heater is set for use on natural gas, a slight yellow tipping of the flame may occur.

## CARE AND MAINTENANCE

**NOTE:** Before servicing you will need to remove the front panel of the heater. There are 4 Philips head screws, 2 on the left side and 2 on the right, securing the front panel to the heater (See Fig. 30). Always allow the unit to cool for at least thirty minutes before attempting to remove the front panel.

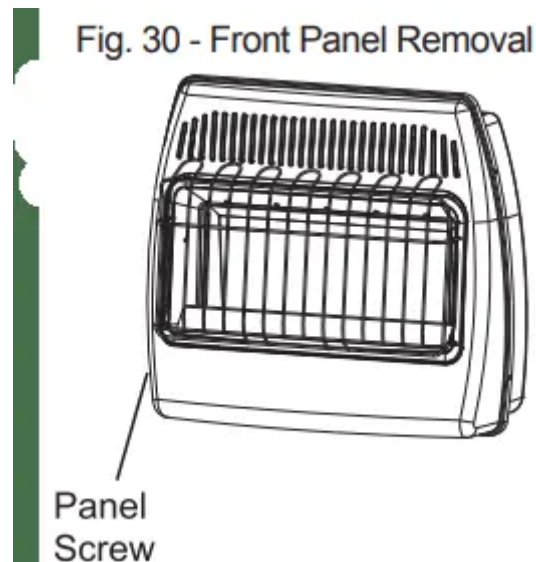

**WARNING:** Turn off heater, unplug electrical cord and let cool before servicing.

**CAUTION:** You must keep control areas, burner, and circulating air passageways of heater clean. Inspect these areas of heater before each use. Have heater inspected yearly by a qualified service person. Heater may need more frequent cleaning due to excessive lint from carpeting, bedding material, pet hair, etc.

**WARNING:** Failure to keep the primary air opening(s) of the burner(s) clean may result in sooting and property damage.

## CLEANING ODS/PILOT AND BURNER

Use a vacuum cleaner, pressurized air, or a small, soft bristled brush to clean burner ports, orifice and primary burner. Look into burner opening and ensure that it is clean.

## CLEANING BURNER PILOT AIR INLET HOLE

We recommend that you clean the unit every three months or after 2,500 hours of operation. We also recommend that you keep the burner tube and pilot assembly clean and free of dust and dirt. To clean these parts we recommend using compressed air no greater than 30 PSI. You can use a vacuum cleaner in the blow position. If using compressed air in a can, please follow the directions on the can. If you don't follow directions on the can, you could damage the pilot assembly.

**CAUTION:** Never use a wire, needle, or similar object to clean ODS/pilot. This can damage ODS/pilot unit

1. Shut off the unit, including the pilot. Allow the unit to cool for at least thirty minutes.
2. Remove 4 screws - 2 screws on each side of the front panel.
3. Pull front panel forward.
4. Blow air through the ports/slots and holes in the burner. Also clean the pilot assembly. A yellow tip on the pilot flame indicates dust and dirt in the pilot assembly. There is a small pilot air inlet hole about two inches from where the pilot flame comes out of the pilot assembly (see Fig. 26 & 27 on page 19). With the unit off, lightly blow air through the air inlet hole. You may blow through a drinking straw if air is not available.
5. Replace front panel when completed, using the screws removed.

## CLEANING CABINET AIR PASSAGEWAYS

Use a vacuum cleaner or pressurized air to clean.

## CLEANING FAN (Select Models)

Carefully use a vacuum cleaner or compressed air to keep fan compartment and blades free of dust and debris.

**NOTE:** The fan motor is pre-lubricated for extended bearing life and requires no further lubrication.

## CLEANING EXTERIOR

Use a soft cloth dampened with a mild soap and water mixture. Wipe the cabinet to remove dust.

# TROUBLESHOOTING

**WARNING:** If you smell gas:

- Shut off gas supply.

- Do not try to light any appliance.
- Do not touch any electrical switch; do not use any phone in your building.
- Immediately call your gas supplier from a neighbor's phone. Follow the gas supplier's instructions.
- If you cannot reach your gas supplier, call the fire department.

**IMPORTANT:** Operating heater where impurities in air exist may create odors. Cleaning supplies, paint, paint remover, cigarette smoke, cements and glues, new carpet or textiles, etc., create fumes. These fumes may mix with combustion air and create odors

**WARNING:** Make sure that power is turned off before proceeding.

**WARNING:** Turn off and let cool before servicing. Only a qualified service person should service and repair heater.

PROBLEM	POSSIBLE CAUSE	CORRECTIVE ACTION
When Ignitor is pressed in, there is no spark at ODS/ pilot.	<ol style="list-style-type: none"> <li>1. Ignitor electrode is positioned wrong.</li> <li>2. Ignitor electrode is broken.</li> <li>3. Ignitor electrode is not connected to ignitor cable.</li> <li>4. Ignitor cable is pinched or wet.</li> <li>5. Damaged ignitor cable.</li> <li>6. Bad ignitor or ignition module.</li> <li>7. Bad battery.</li> </ol>	<ol style="list-style-type: none"> <li>1. Replace ODS.</li> <li>2. Replace ODS.</li> <li>3. Replace ignitor cable</li> <li>4. Free ignitor cable if pinched by any metal or tubing. Keep ignitor cable dry.</li> <li>5. Replace ignitor cable.</li> <li>6. Replace ignitor or ignition module.</li> <li>7. Replace the battery.</li> </ol>
Unit shuts off after running a few minutes.	<ol style="list-style-type: none"> <li>1. Gas supply is turned off or equipment shutoff valve is closed.</li> <li>2. Control knob not fully pressed in while pressing Ignitor.</li> <li>3. Air in gas lines when installed.</li> <li>4. ODS / pilot is clogged.</li> <li>5. Control knob not in PILOT position.</li> <li>6. Depleted gas supply (propane)</li> </ol>	<ol style="list-style-type: none"> <li>1. Turn on gas supply or open equipment shutoff valve.</li> <li>2. Fully press in control knob while pressing Ignitor.</li> <li>3. Continue holding down control knob. Repeat igniting operation until air is removed</li> <li>4. Clean ODS/pilot (see Care and Maintenance, page 22) or replace ODS/pilot assembly.</li> <li>5. Turn control knob to PILOT position.</li> <li>6. Contact local propane/ LP gas company</li> </ol>
ODS/pilot lights but flame goes out when	<ol style="list-style-type: none"> <li>1. Control knob is not fully pressed in.</li> </ol>	<ol style="list-style-type: none"> <li>1. Press in control knob fully.</li> </ol>



<p>control knob is released.</p>	<ol style="list-style-type: none"> <li>2. Control knob is not pressed in long enough.</li> <li>3. Equipment shutoff valve is not fully open.</li> <li>4. Thermocouple connection is loose.</li> <li>5. Thermocouple damaged.</li> <li>6. Control valve damaged.</li> <li>7. Inlet gas pressure is too high</li> </ol>	<ol style="list-style-type: none"> <li>2. After ODS/pilot lights, keep control knob pressed in 30-60 seconds.</li> <li>3. Fully open equipment shutoff valve.</li> <li>4. Hand tighten until snug, and then tighten ¼ turn more.</li> <li>5. Replace thermocouple.</li> <li>6. Contact customer service.</li> <li>7. Contact your gas supplier to check and adjust the inlet pressure.</li> </ol>
<p>Burner(s) does not light after ODS/pilot is lit.</p>	<ol style="list-style-type: none"> <li>1. Thermostat setting too low.</li> <li>2. Burner orifice is clogged.</li> <li>3. Burner orifice diameter is too small.</li> <li>4. Inlet gas pressure is too low.</li> </ol>	<ol style="list-style-type: none"> <li>1. Turn thermostat knob to a higher setting.</li> <li>2. Clean burner orifice (see Care and Maintenance, page 22) or contact customer service.</li> <li>3. Contact customer service.</li> <li>4. Contact your gas supplier.</li> </ol>
<p>Delayed ignition of burner(s).</p>	<ol style="list-style-type: none"> <li>1. Manifold pressure is too low.</li> <li>2. Burner orifice is clogged.</li> </ol>	<ol style="list-style-type: none"> <li>1. Contact your gas supplier.</li> <li>2. Clean burner (see Care and Maintenance, page 22) or contact customer service.</li> </ol>
<p>Burner backfiring during combustion.</p>	<ol style="list-style-type: none"> <li>1. Burner orifice is clogged or damaged.</li> <li>2. Burner is damaged.</li> </ol>	<ol style="list-style-type: none"> <li>1. Clean burner orifice (see Care and Maintenance, page 22) or contact customer service.</li> </ol>



	<ol style="list-style-type: none"> <li>3. Gas regulator is damaged.</li> </ol>	<ol style="list-style-type: none"> <li>2. Contact dealer or customer service.</li> <li>3. Replace gas regulator.</li> </ol>
High yellow flame during burner combustion	<ol style="list-style-type: none"> <li>1. Not enough air.</li> <li>2. Gas regulator is defective.</li> </ol>	<ol style="list-style-type: none"> <li>1. Check burner for dirt and debris. If found, clean burner (see Care and Maintenance, page 22).</li> <li>2. Replace gas regulator.</li> </ol>
Gas odor during combustion.	<ol style="list-style-type: none"> <li>1. Foreign matter between control valve and burner.</li> <li>2. Gas leak. (See Warning Statement at top of page 23).</li> </ol>	<ol style="list-style-type: none"> <li>1. Take apart gas tubing and remove foreign matter.</li> <li>2. Locate and correct all leaks (see "Checking Gas Connections," page 18).</li> </ol>
Heater produces a clicking/ticking noise just after burner is lit or shut off.	<ol style="list-style-type: none"> <li>1. Metal is expanding while heating or contracting while cooling.</li> </ol>	<ol style="list-style-type: none"> <li>1. This is common with most heaters. If noise is excessive, contact qualified service technician.</li> </ol>
White powder residue forming within burner box or on adjacent walls or furniture.	<ol style="list-style-type: none"> <li>1. When heated, the vapors from furniture polish, wax, carpet cleaners, etc., turn into white powder residue.</li> </ol>	<ol style="list-style-type: none"> <li>1. Turn heater off when using furniture polish, wax, carpet cleaner or similar products.</li> </ol>
Heater produces unwanted odors.	<ol style="list-style-type: none"> <li>1. Heater is burning vapors from paint, hair spray, glues, etc. See IMPORTANT statement, page 23.</li> <li>2. Gas leak. See Warning Statement, page 23.</li> <li>3. Low fuel supply.</li> </ol>	<ol style="list-style-type: none"> <li>1. Ventilate room. Stop using odor causing products while heater is running.</li> <li>2. Locate and correct all leaks (see "Checking Gas Connections," page 17).</li> </ol>

		3. Refill supply tank (Propane /LP models)
Heater shuts off in use (ODS operates).	<ol style="list-style-type: none"> <li>1. Not enough fresh air is available.</li> <li>2. Low line pressure.</li> <li>3. ODS/pilot is partially clogged.</li> </ol>	<ol style="list-style-type: none"> <li>1. Open window and/or door for ventilation.</li> <li>2. Contact local gas supplier.</li> <li>3. Clean ODS/pilot (see Care and Maintenance, page 22).</li> </ol>
Gas odor exists even when control knob is in OFF position.	<ol style="list-style-type: none"> <li>1. Gas leak. See Warning Statement at top of page 23.</li> <li>2. Control valve is defective.</li> </ol>	<ol style="list-style-type: none"> <li>1. Locate and correct all leaks (see “Checking Gas Connections”, page 17).</li> <li>2. Contact customer service.</li> </ol>
Moisture/condensation noticed on windows.	<ol style="list-style-type: none"> <li>1. Not enough combustion/ventilation air.</li> </ol>	<ol style="list-style-type: none"> <li>1. Refer to “Air for Combustion and Ventilation” requirements, page 8.</li> </ol>
Slight smoke or odor during initial operation	<ol style="list-style-type: none"> <li>1. Residues from manufacturing process.</li> </ol>	<ol style="list-style-type: none"> <li>1. Problem will stop after a few hours of operation.</li> </ol>
Heater produces a whistling noise when burner is lit.	<ol style="list-style-type: none"> <li>1. Turning control knob to high (5) position when burner is cold.</li> <li>2. Air in gas line.</li> <li>3. Air passageways on heater are blocked.</li> <li>4. Dirty or partially clogged burner orifice.</li> </ol>	<ol style="list-style-type: none"> <li>1. Turn control knob to low (1) position and let warm up for a minute.</li> <li>2. Operate burner until air is removed from line. Have gas line checked by local propane/LP gas company.</li> <li>3. Observe minimum installation clearances (Fig. 3, page 11)</li> </ol>



		4. Clean burner (see Care and Maintenance, page 22) or contact customer service.
Fan is not spinning. (Select Models)	<ol style="list-style-type: none"> <li>1. There is no power to the fan.</li> <li>2. Fan is set to "AUTO".</li> <li>3. Fan motor is bad.</li> </ol>	<ol style="list-style-type: none"> <li>1. Verify fan is plugged in and set to "MAN" or "AUTO".</li> <li>2. Allow 5-10 minutes for fan to engage.</li> <li>3. Replace fan.</li> </ol>
Fan is making a loud noise. (Select Models)	<ol style="list-style-type: none"> <li>1. Fan housing or blades are dirty.</li> <li>2. Fan rotation is blocked.</li> <li>3. Defective fan.</li> </ol>	<ol style="list-style-type: none"> <li>1. See "Cleaning Fan", page 22.</li> <li>2. Verify wiring is not in fan path.</li> <li>3. Replace fan.</li> </ol>

## REPLACEMENT PARTS LIST

For replacement parts, call our customer service department at 1-877-447-4768, 8:30 a.m. – 4:30 p.m., CST, Monday – Friday.

**WARNING:** Only use genuine replacement parts from the GHP Group, Inc. Using any parts other than the original replacement parts may result in property damage, personal injury or even death.

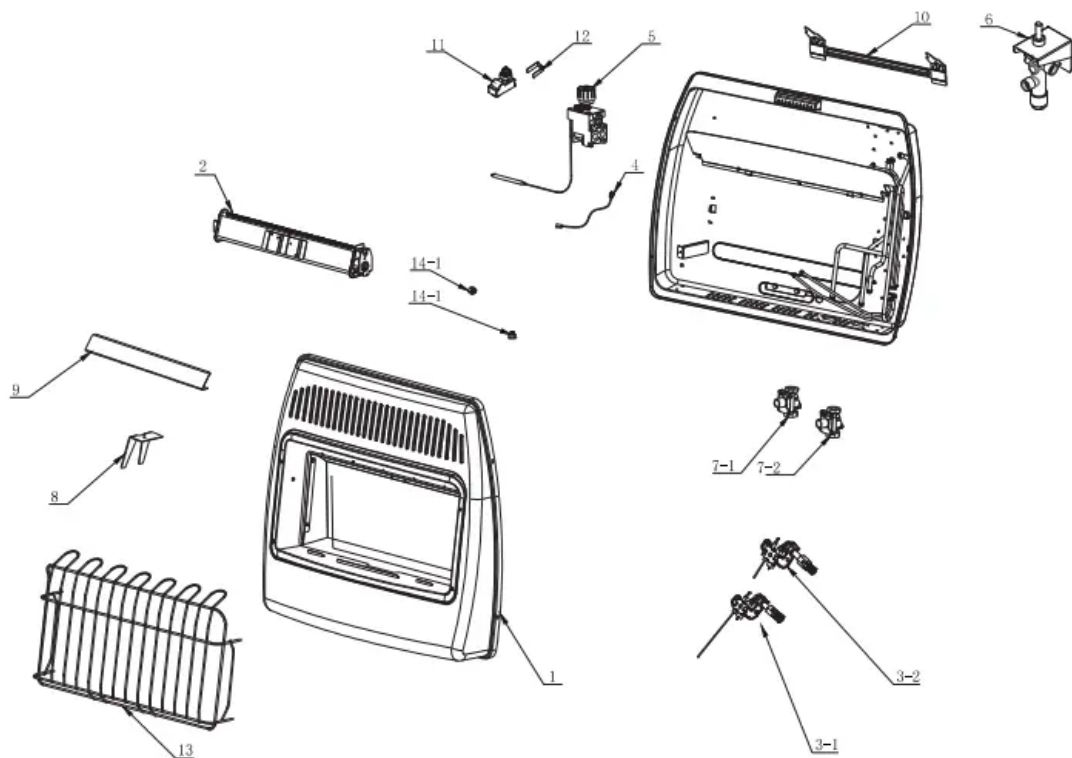

Item No.	Description	Qty	Part Number					
			BF10PTDG-4/ PMDG-4	BF10NTDG-4/ NMDG-4	BF20PTDG-4/ PMDG-4	BF20NTDG-4/ NMDG-4	BF30PTDG-4/ PMDG-4	BF30NTDG-4/ NMDG-4
1	Front Panel Assembly	1	AQ000090A		AQ000174		AQ000175	
2	Burner Assembly	1	AQ000165					
3-1	ODS - (LP) Propane Gas Pilot	1	BF30K-39(LP)(L=950)	N/A	BF30K-39(LP)(L=950)	N/A	BF30K-39(LP)(L=950)	N/A
3-2	ODS - (NG) Natural Gas Pilot	1	N/A	BF30K-39(NG)(L=950)	N/A	BF30K-39(NG)(L=950)	N/A	BF30K-39(NG)(L=950)
4	Ignition Wire	1	BF30K-38 (L=1050)		BF30K-38 (L=1050)		BF30K-38 (L=1050)	
5	Thermostatic Gas Valve, SIT 630	1	0630560	N/A	0630560	N/A	0630560	N/A
6	Manual Gas Valve	1	N/A	GS7A-GHP	N/A	GS7E-GHP	N/A	GS7D-GHP
7-1	NG Regulator Assembly	1	N/A	GR-130B3-GHP	N/A	GR-130B2-GHP	N/A	GR-130B-GHP
7-2	LP Regulator Assembly	1	GR-130A3-GHP	N/A	GR-130A2-GHP	N/A	GR-130A-GHP	N/A
8	Primary Air Shield	1	BF10K-28		BF30K-37		BF30K-37	
9	Front Air Deflector	1	BF10K-27		BF20K-18		BF30K-36	
10	Wall Mounting Bracket	1	AQ000108		AQ000006		AQ000006	
11	Ignitor Module	1	AQ000221		AQ000221		AQ000221	
12	Ignitor Bracket	1	AQ000019		AQ000019		AQ000019	
13	Front Grill	1	AQ000099		AQ000063		AQ000023	
14-1	Replacement Orifice (LP)	1	BF10K-LP	N/A	BF20K-LP	N/A	BF30K-LP	N/A
14-2	Replacement Orifice (NG)	1	N/A	BF10K-NG	N/A	BF20K-NG	N/A	BF30K-NG
15	Hardware Pack	1	AQ000233*		AQ000233*		AQ000233*	

\* Item/version not shown in exploded parts diagram

## Warning

This content is compiled from multiple sources and is provided for reference purposes only. It may not be complete or fully applicable to all situations. If you are unable to resolve your issue, please contact the product manufacturer or an authorized service provider for official support.