

Operating instructions Dishwasher

Getting Started

Appliance overview

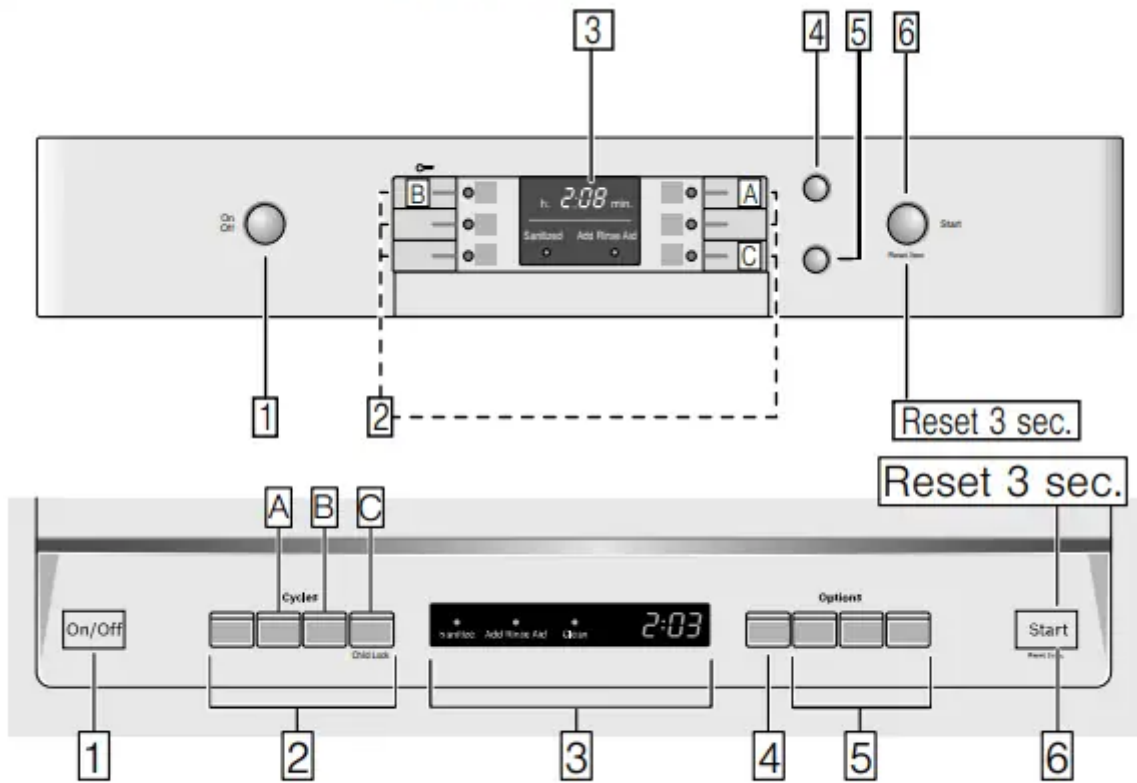

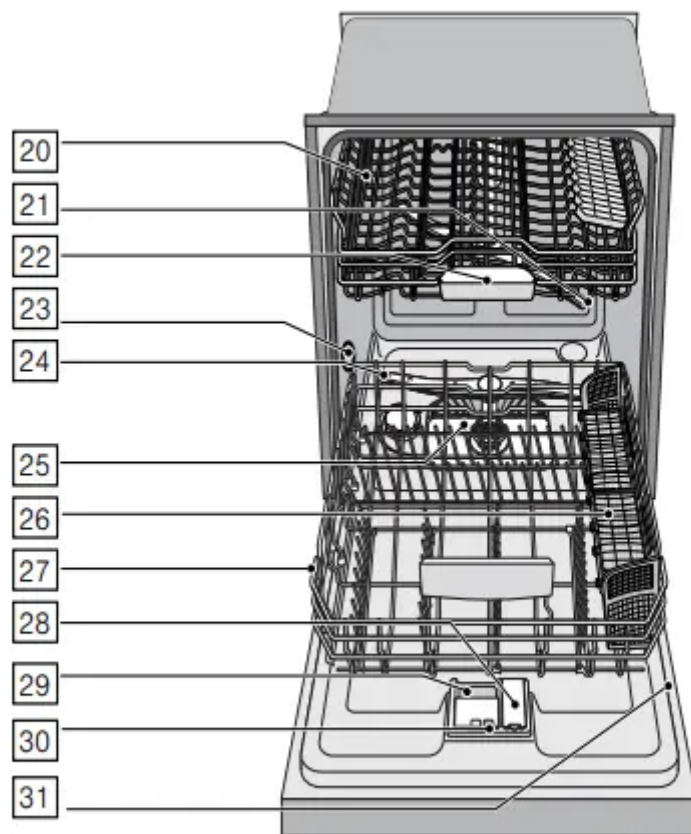

The dotted lines show optional features which may or may not be included with your dishwasher. The numbers stated below refer to the overview images on the previous page of this manual.

Operating panel

- 1 On/Off button
- 2 Wash cycles**
- 3 Digital display
- 4 Delay start button
- 5 Wash cycle options**
- 6 Start button

**number of wash cycles and options varies on specific model number

Dishwasher interior components

- 20 Upper rack
- 21 Upper spray arm

- 22 Detergent tab tray
- 23 Vent hole
- 24 Lower spray arm
- 25 Filters
- 26 Silverware basket
- 27 Lower rack
- 28 Rinse aid dispenser
- 29 Detergent dispenser
- 30 Lock for detergent dispenser
- 31 Rating plate

Display indicators

•  : Cycle time remaining

- Sanitize: Lights up when sanitation requirements are met
- Add Rinse Aid: Lights up when rinse aid is low
- Clean *: Lights up when dishes are clean

* optional feature which may or may not be included with your dishwasher.

Menu overview

The dishwasher has been preset with certain settings for your convenience. You can change these factory settings.

Use the function keys A, B and C to change the settings.

Setting -- Factory setting -- Description

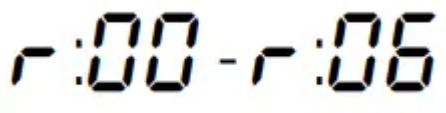
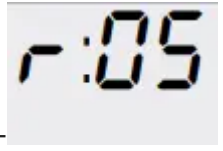
1.  Rinse aid ;  --  : Amount of
rinse aid affects drying. When using Multitabs, select setting 0.

2.  Intensive drying * ;  --  / Off:
Improved drying for glasses and plasticware.

3.

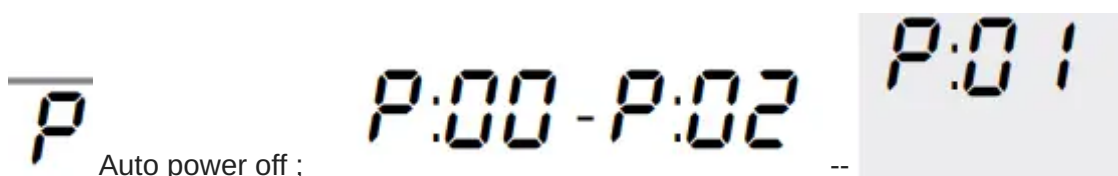

Auto power off ;

Dishwasher switches off automatically after wash cycle is complete.

* depending on the features of your dishwasher

Rinse Aid



Rinse Aid

- To achieve proper drying, always use a liquid rinse aid, even if your detergent contains a rinse aid or drying additive.
- Note: The dishwasher indicates low rinse aid by turning on the Rinse Aid indicator. If this indicator lights up, you need to refill the rinse aid dispenser 28 by following the directions below.

Adding rinse aid

NOTICE: To avoid oversudsing or clogging, do not overfill the rinse aid dispenser 28. Wipe up any spills with a damp cloth.

1. Open the rinse aid dispenser 28 by pressing on the latch of the lid and pull it open.

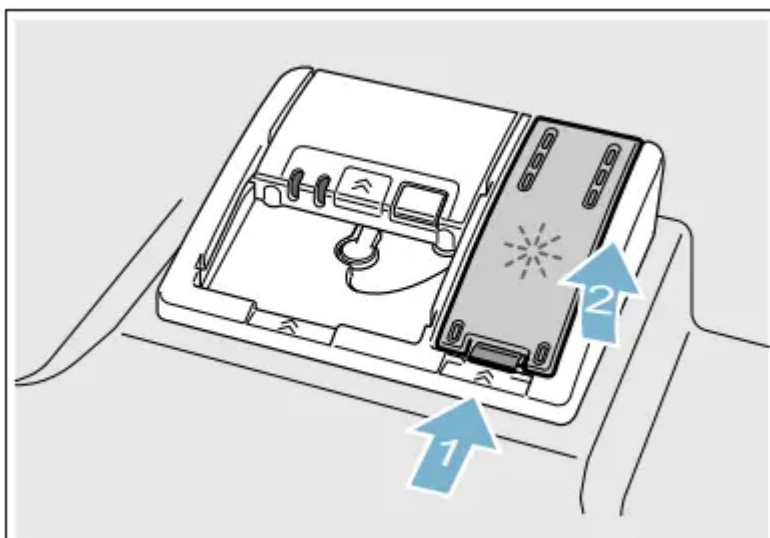

2. Add liquid rinse aid to the dispenser 28 until it is full. Do not overfill. Avoid spilling into air

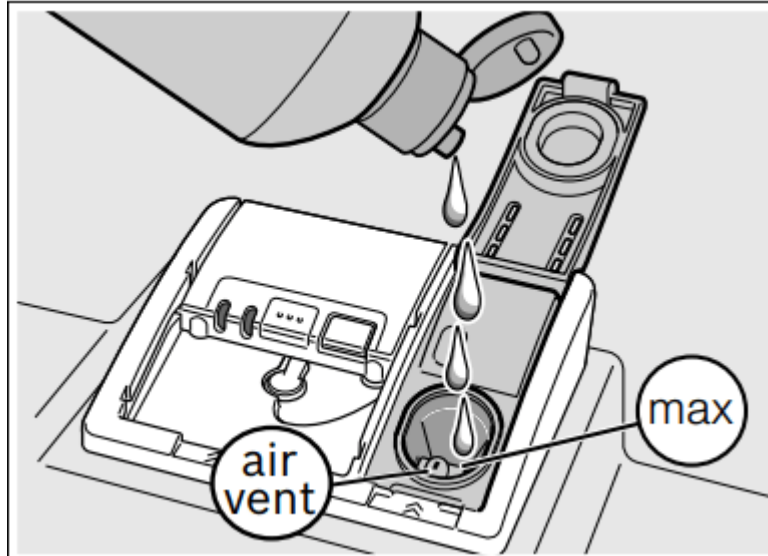

vent hole.

3. Close the lid. Lid must be fully closed until it clicks in order to seal.

4. Wipe up any excess rinse aid that may have puddled when the dispenser reservoir is full.

The indicator light will go out a few moments after the dishwasher door is shut.

Tip: For easier pouring, remove lid from the rinse aid bottle.

NOTICE: Do not fill the rinse aid dispenser 1b with detergent. Doing so will damage the dishwasher.



Setting the amount of rinse aid used

• The amount of rinse aid dispensed can be set from r:00 to r:06. The factory setting is r:05.

- You should only change the setting if streaks remain on the dishes (lower the amount), or if dishes are not getting dry enough (increase the amount).

Setting

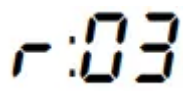
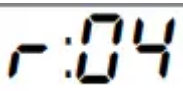
- r:00 dispenser is OFF
- r:01 lowest setting
- r:02 low setting

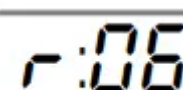
-  medium setting
-  medium/high setting
-  high setting
-  highest setting

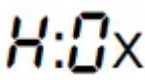
1. Press the On/Off button 1.
2. Hold down the function key A and press the Start button 6 until the display 3 indicates  (x can be any number). Release both buttons.

3. Press the function key A until the display 3 shows 



4. Press the function key C to select the desired setting.

5. Press the Start button 6 to save the setting.

Turning off rinse aid indicator

- Proceed as described in the section “Setting the amount of rinse aid used” and set value

to  The rinse aid indicator is now turned off.

- 
 NOTICE: Using no rinse aid or setting the dispenser to  may result in longer cycle times consuming more energy and water. The higher temperatures and longer cycle times can damage fine china or glassware.

Loading the Dishwasher

Dishware material

Note: Before using your dishwasher for the first time, check the information in this section. Some items are not dishwasher-safe and should be hand washed; others require special loading.

Recommended

1. Aluminum: Colored anodized aluminum may fade over time. Minerals in your water may cause the aluminum to darken or spot. This can usually be removed with a soap-filled steel wool pad.
2. China, Crystal, Stoneware: Some hand-painted utensils may discolor, fade or spot. Hand wash these utensils. Position fragile glassware so that it will not topple over or come in contact with other utensils during the wash cycle.
3. Glass: Make sure to use dishwasher-safe glass. Milk glass may discolor or become yellow.
4. Non-stick Coatings: Apply a light coating of vegetable oil to non-stick surfaces after drying.
5. Plastics: Make sure the plasticware is dishwasher-safe.
6. Stainless Steel, Sterling Silver and Silver Plates: Load these so they do not come in contact with other metals, stainless steel dishwasher tub walls or the inner door.

Not Recommended

- Acrylic: Crazeing or small cracks throughout the acrylic, may occur.
- Adhesive Joined Pieces: Adhesives that join materials such as plastic, wood, bone, steel, copper, tin, etc. may loosen.
- Bone-Handled: Utensils Handles may separate. Iron Iron will rust. Hand wash and dry immediately.
- Non-Dishware Items: Your dishwasher is intended for use in cleaning ONLY standard household dishware and kitchenware.
- Pewter, Brass, Bronze: These items will tarnish. Hand wash and dry immediately. Tin Tin will stain. Hand wash and dry immediately.
- Wood: Wooden bowls, wooden utensils and utensils with wooden handles can crack, warp and lose their finish.

Loading the racks

For best dishwashing results, observe the following when loading the dishwasher:

- Do not pre-wash items with loosely attached food soil.
- Remove all food particles, bones, toothpicks and excessive grease.
- Pre-treat items having burned-on, baked-on or starchy soils.
- Load dishes in the dishwasher racks so the insides of bowls, pots and pans are facing the spray arms.
- Avoid nesting and contact points between dishes.
- Separate items of dissimilar metals. Use care to not block movement of the spray arms.

- Only wash household dishware and kitchenware rated as dishwasher-safe. Refer to the Dishware Materials section for more information about dishware suitability

NOTICE: To avoid dishwasher damage, do not load the dishwasher with paper products, plastic bags, packing materials or anything other than normal, dishwasher safe dishware and kitchenware.

Loading the upper rack

- Ensure items do not protrude through the bottom of the racks and block the spray arms.
- Note: When pushing the upper rack 20 into the dishwasher, push it until it stops against the back of the tub so the upper rack spray arm 21 connects to the water supply at the back of the tub. Do not push racks in using the door.

Loading the lower rack

- Place large items in the lower rack 27. Load pots, pans and bowls upside down. Do not block the vent hole 23 with tall baking sheets. Load these items on the right side of the dishwasher.

Suggested loading pattern

10 place setting

Lower rack 27

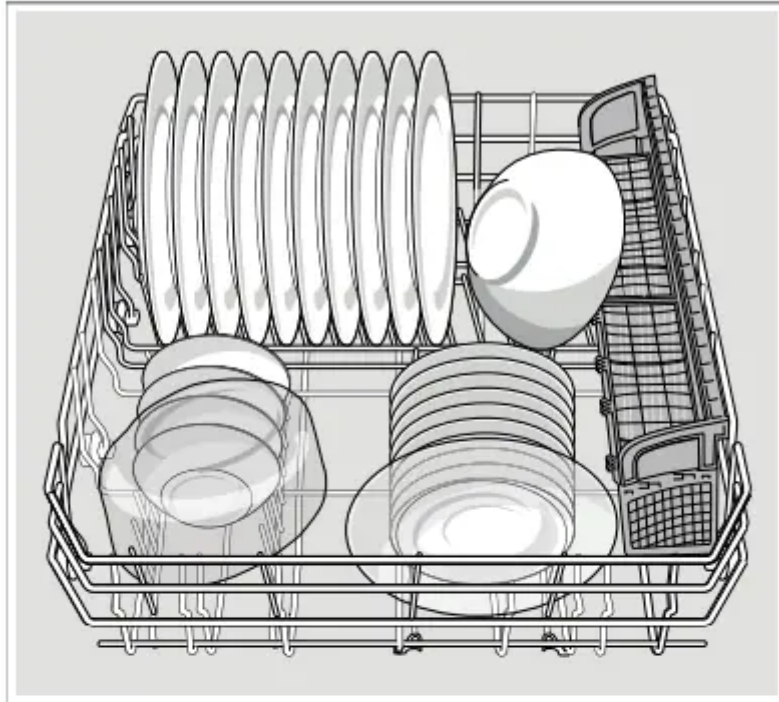

Upper rack 20

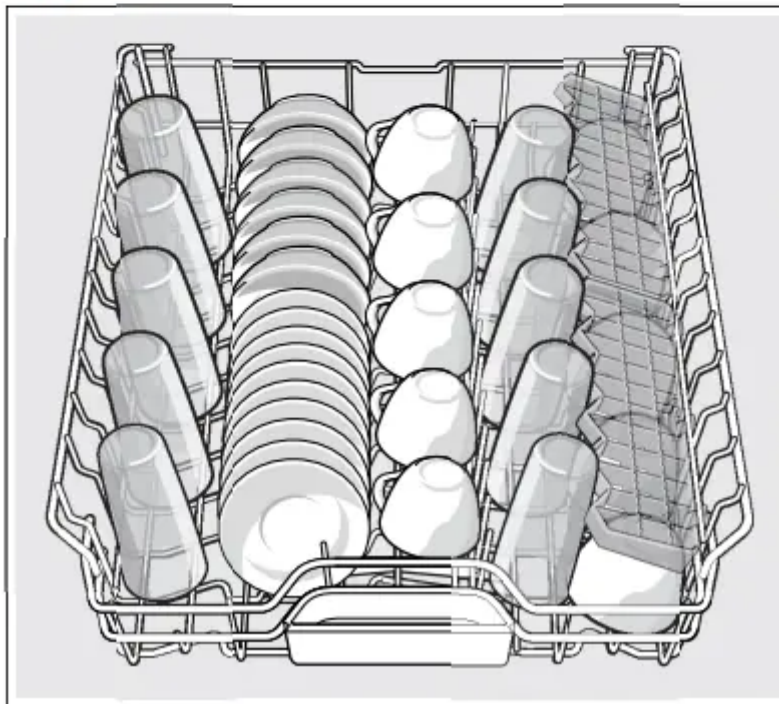

Note: Folding the cup shelves down will allow the cups to sit at an increased angle and reduce water pooling on cup bottoms.

Additional loading pattern

12 place setting

Lower rack 27

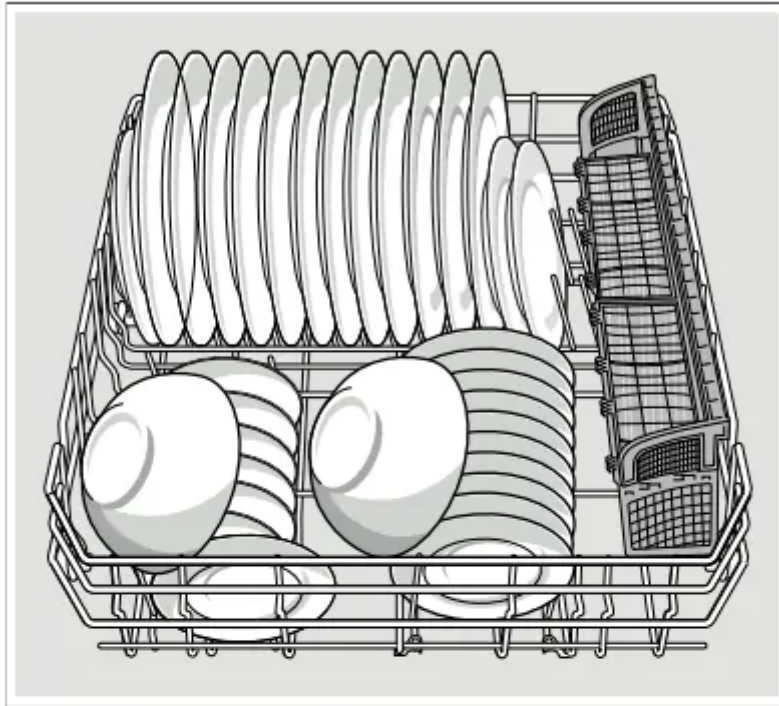

Upper rack 20

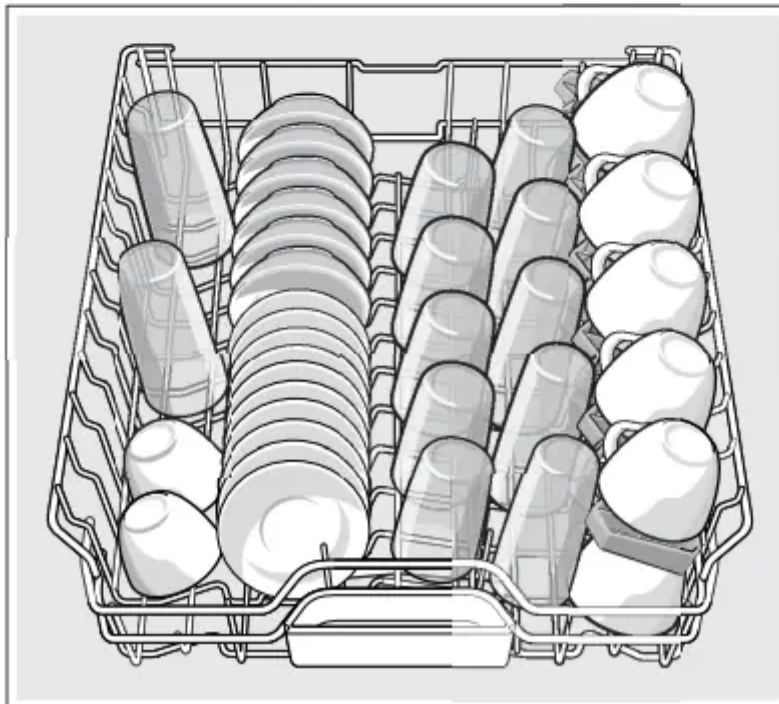

Note: Folding the cup shelves down will allow the cups to sit at an increased angle and reduce water pooling on cup bottoms.

Loading the silverware basket

Place knives and sharp utensils with their handles up and forks and spoons with their handles down. If large or oddly-shaped items are loaded in the silverware basket, be sure they do not nest together.

WARNING - RISK OF INJURY! The sharp points and edges of knives and other sharp utensils can cause serious injury. Load knives and other sharp utensils with edges down. Do not allow children to handle or play near knives and sharp utensils

Long silverware basket

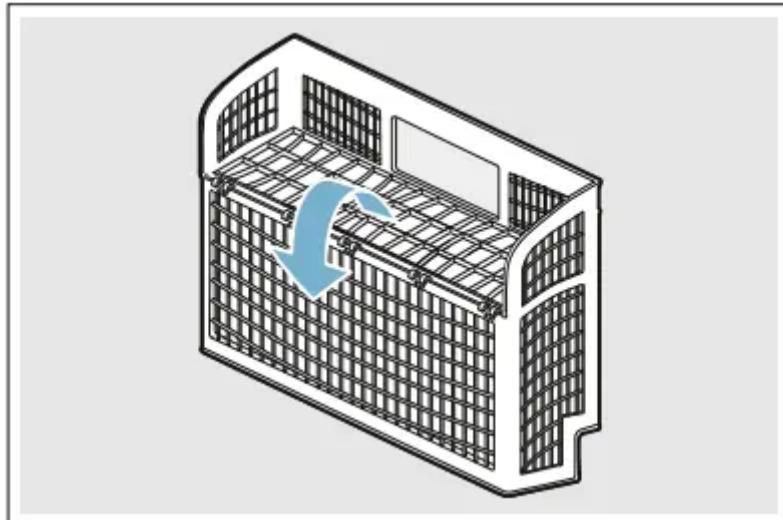

- Note: The silverware basket lid may also be folded downward in order to leave the basket open.

Suggested loading patterns

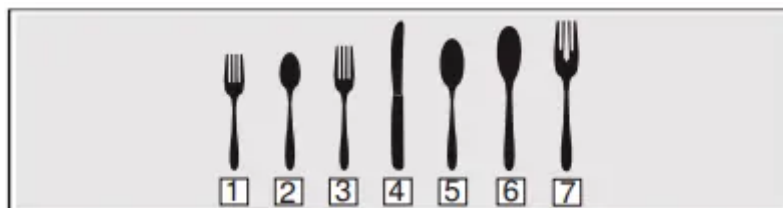

- 1 Salad fork
- 2 Teaspoon
- 3 Dinner fork
- 4 Knife
- 5 Tablespoon
- 6 Serving spoon
- 7 Serving fork

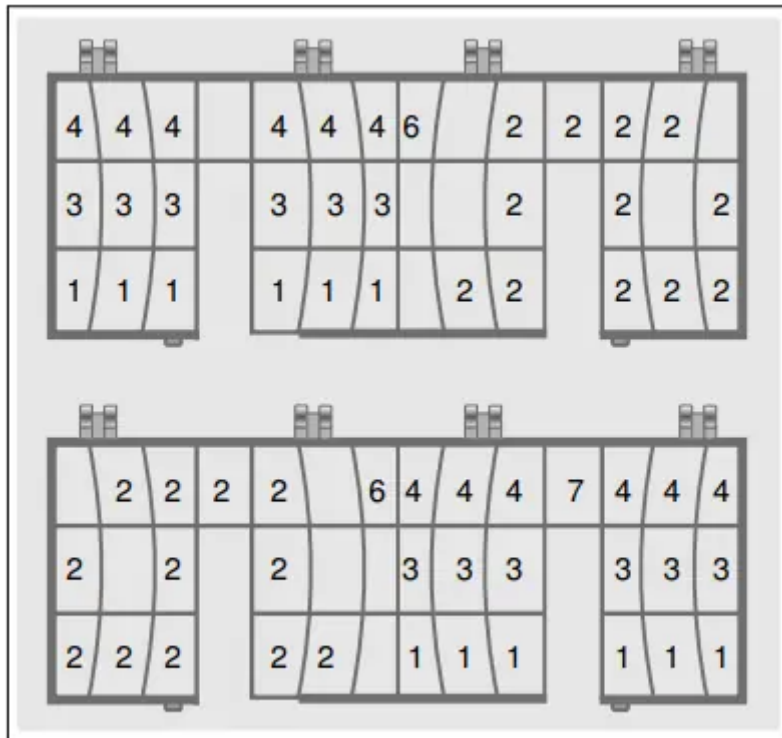

Unloading the dishwasher

- CAUTION: Dishes can be very hot immediately after cycle ends. Open the door slightly and allow dishes to cool for a few minutes before unloading.
- Note: Dishes are more likely to chip when unloading before cooling.
- When unloading the dishwasher, to prevent water from dripping onto dry dishes, unload the lower rack 27 first. Next, unload the silverware basket 26 followed by the upper rack 20, and then the third rack (if equipped).

Adjustable Upper Rack

If desired, the height of the upper rack can be adjusted to accommodate larger items in the lower rack.

1. Pull the empty upper rack 20 out, tilt it up, and pull it all the way out until it is free of the

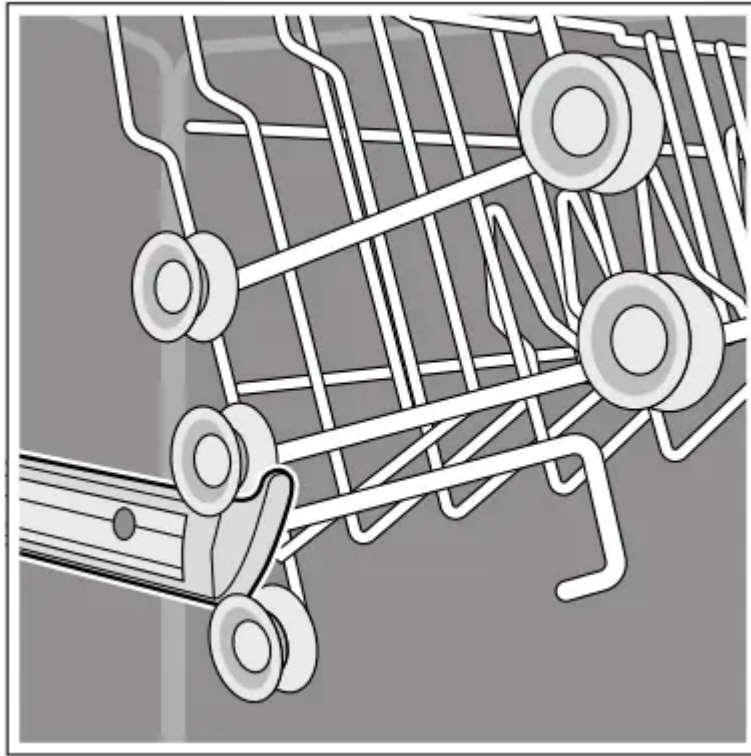

roller guides.

2. Re-insert the rack with the other set of roller guides as shown below.

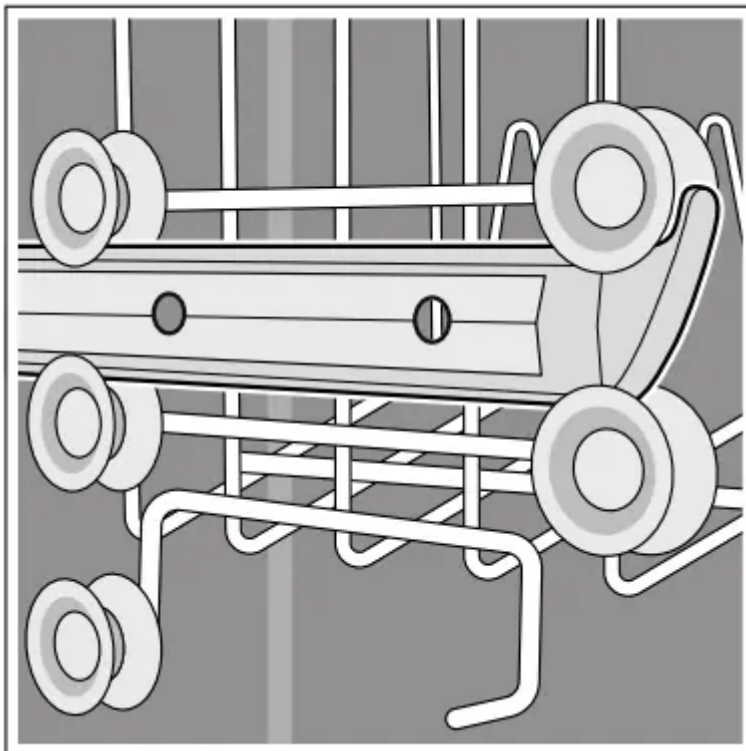

Rack accessories

Flip tines*

- The upper and lower rack are fitted with flip tines that can be folded down depending on what you may need to load in the rack.
- Lower rack flip tines: To fold down, pull flip tine gently forward and release it from the notch. Push the flip tine downward. To fold up, push flip tines into an upright position until the holder engages in the notch.

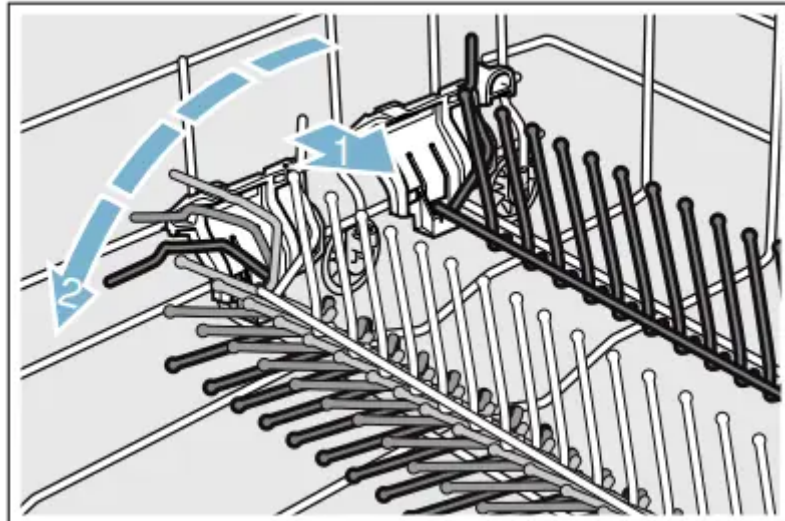

- Upper rack flip tines: To fold down, push flip tines downward with gentle pressure. To fold up, push flip tines into an upright position until the holder engages in the notch.

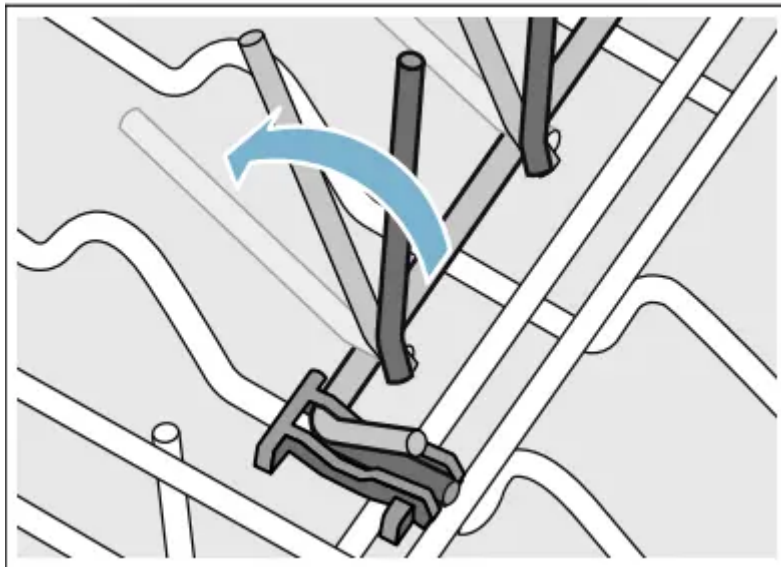

* optional feature which may or may not be included with your dishwasher.

Cup shelves*

- The cup shelves and the space underneath them can be used for small cups or for larger serving utensils.

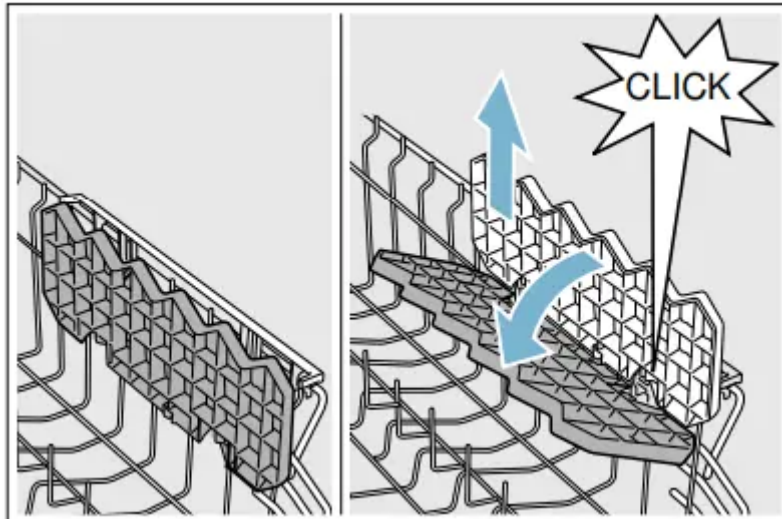

* optional feature which may or may not be included with your dishwasher.

Utility rack *

- Long knives and other utensils can be placed on the utility rack.

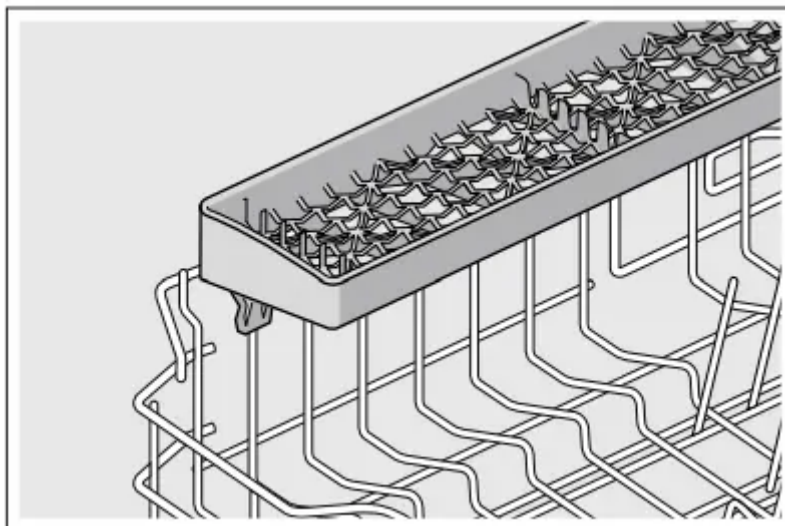

* optional feature which may or may not be included with your dishwasher.

Detergent

Use only detergent specifically designed for dishwashers. For best results, use fresh powdered dishwashing detergent or detergent tabs.

NOTICE: To avoid damage to dishwasher or dishware:

- Do not use hand dishwashing products in your dishwasher.
- Do not use too much detergent if your water is soft. Using too much detergent with soft water may cause etching in glassware and fine china.

- To best protect glassware, use a wash cycle with low temperatures or a specific glass-care cycle (depending on the model) and use a detergent that includes etch protection.

This dishwasher uses less water than most, therefore, less detergent is required. With soft water, 1 tablespoon (15 ml) of detergent will clean most loads. The detergent dispenser cup has lines that measure detergent to 1 tablespoon (15 ml) and 1.75 tablespoons (25 ml). 3 tablespoons (45 ml) of detergent will completely fill the detergent dispenser.

Note: If you do not know the hardness of your water supply, use 15 ml of detergent. Increase the amount if necessary to the least amount required to get your kitchenware clean.

Use the measuring lines in the detergent dispenser cup as a guide to measure the amount of detergent recommended in the following table.

Wash Cycle	Hard Water/ Heavy Soil	Medium Water/ Medium Soil	Soft Water/ Little Soil
Heavy	3 tbsp (45 ml)	3 tbsp (45 ml)	1.75 - 3 tbsp (25 - 45 ml)
Auto	1.75 - 3 tbsp (25 - 45 ml)	1.75 tbsp (25 ml)	1 - 1.75 tbsp (15 - 25 ml)
Normal	1.75 - 3 tbsp (25 - 45 ml)	1.75 tbsp (25 ml)	1 - 1.75 tbsp (15 - 25 ml)
Delicate	1.75 tbsp (25 ml)	1 - 1.75 tbsp (15 - 25 ml)	1 tbsp (15 ml)
Speed60®	1.75 tbsp (25 ml)	1 - 1.75 tbsp (15 - 25 ml)	1 tbsp (15 ml)
Rinse	none	none	none

Adding detergent

1. If the detergent dispenser 29 is still closed, push the button 30 to open it. Note: Make sure the detergent dispenser is dry and clear of detergent residue.

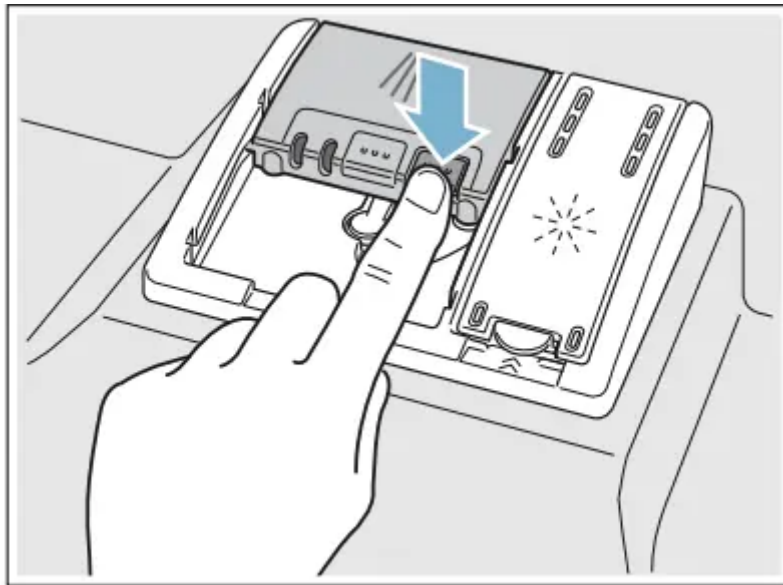

2. When using detergent tabs, lay them such that they do not come in contact with the cover, insert a detergent tab flat, not on its side. Note: Do not place detergent tabs or utensils in the detergent tab tray 22. Place tabs or other detergent forms directly in the detergent dispenser 29.

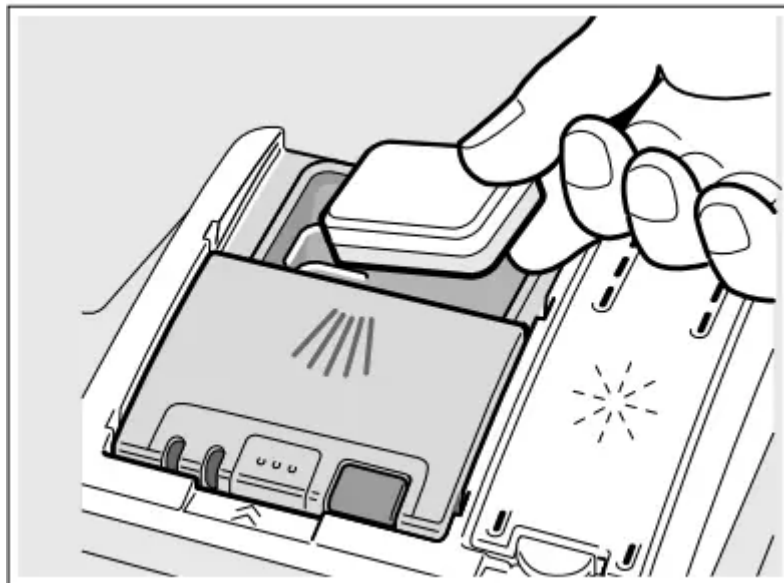

Pour detergent into the dry detergent dispenser 1j only. Add detergent. Do not overfill the detergent dispenser.

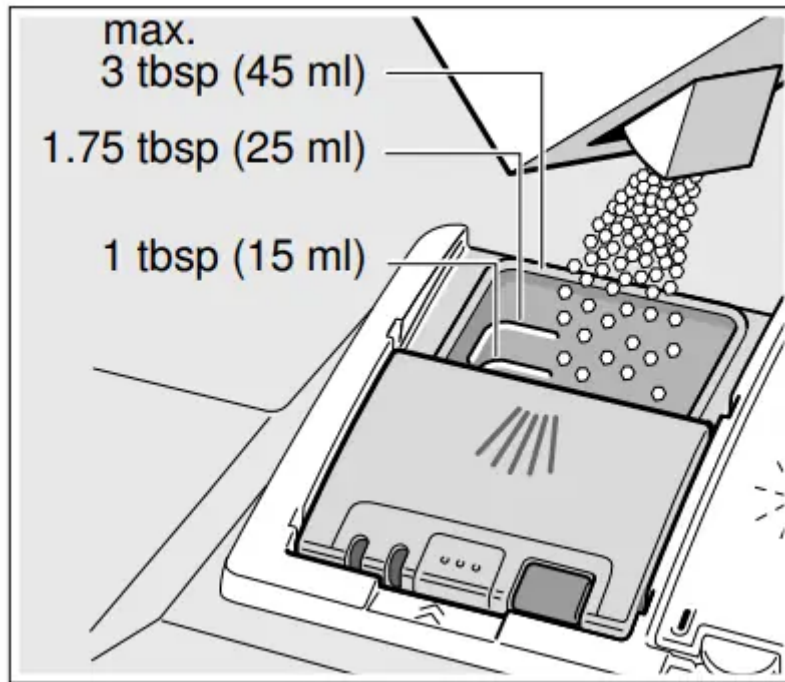

Dosage: see manufacturer's instructions on the packaging.

3. Close the lid by placing the finger on the lid as shown. Slide the lid closed until it clicks.

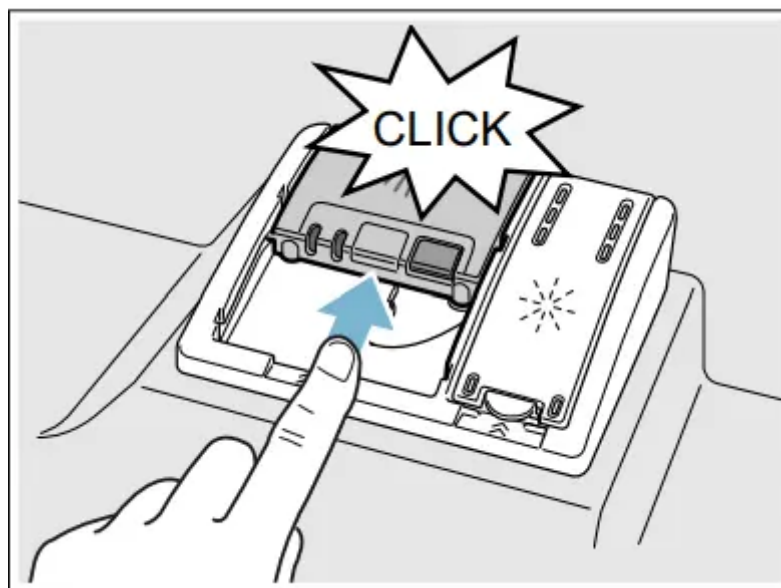

The detergent dispenser will open automatically at the ideal time for the set cycle. The powder or liquid detergent is distributed in the appliance and is dissolved, detergent tabs will fall into the detergent tab tray 22 where it dissolves during the cycle

Tip: If the dishware is only lightly soiled, slightly less than the indicated amount of detergent is usually adequate.

Dishwasher Cycles

Wash cycle --- Recommended use --- Possible wash cycle option

1. Heavy

- Best for cleaning items with baked-on food or grease. These dishes would normally require soaking or hand scouring.
 - all

2. Auto

- Smartest cycle, with most flexible soil sensing, which is ideal for mixed dishware and food soils.
 - all

3. Normal (see note at bottom of table)

- Recommended for daily, regular or typical use to completely wash a full load of normally soiled dishes.
 - all
 - Note: In order to obtain optimal performance with minimum energy consumption, it is recommended to disable all available options and settings,

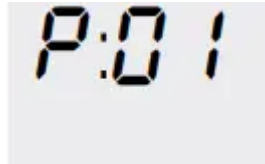

except Auto Power Off - set to

4. Delicate

- Best for delicate dishes and glasses. This cycle lowers temperature and cycle length to protect dishes and decrease energy usage.
 - Delay
 - Speed Perfect *
 - Half Load *
 - Extra Dry® *

5. Speed60®

- Cleans freshly soiled dishes with easy to remove soils. This cycle reduces cycle time while still including drying.
 - Delay
 - Half Load *
 - Extra Dry® *

6. Rinse

- Use this cycle if you need to pre-rinse dishes to avoid odors. Place unrinsed dishes inside the dishwasher and select the Rinse cycle. Uses less water than hand rinsing and very low energy.
 - Delay

Note: The Energy Guide label was based on the Normal soil sensing cycle as follows: The unit was tested without any rinse aid (liquid) in the rinse aid dispenser 28. A single dose of detergent was inserted into the detergent dispenser 29, with no detergent being used in the prewash. The unit was not subjected to truncated testing per the definitions in the test procedure. We recommend that dish loads such as the one in the energy certification test have the rack position set in the highest position.

Dishwasher Cycle Options

P⁺ Dishwasher Cycle Options

- Delay: Allows you to delay the start time of your dishwasher up to 24 hours.
- Sanitize *:
 - Increases the temperatures and retains them for an extra long time to obtain a defined disinfecting performance. Continuous use of this function increases the hygiene status. This additional option is ideal for cleaning items such as chopping boards and baby bottles.
 - Using the Sanitize option may also improve drying. The cycle time and energy usage may be increased.
- SpeedPerfect™*: SpeedPerfect™ is an option that allows saving time without sacrificing wash and dry performance. Selecting this option ensures the same final temperatures as the underlying cycle by starting the heat period at an earlier phase in the program. Selecting this option also increases energy consumption while reducing cycle time.
- Half Load*: Can reduce water consumption when washing small, lightly soiled loads that fill approximately half of the dishwasher's capacity.
- Extra Dry *: An increased temperature during the final rinse and an extended drying phase ensure that plastic parts dry better. There is a slight increase in the energy consumption. * Not on all models. See fascia panel for corresponding programs.

Wash Cycle Information

- To save energy, this dishwasher has EcoSense where the sensors in the dishwasher automatically adjust the cycle length, temperature and water changes based on the amount of food soil and the incoming water temperature. The "Smart Control" makes

decisions that can cause the cycle time and water usage to adjust intermittently. Wash cycle times are based on 120°F (49° C) water supply. If your household water supply is different than 120°F (49° C), your dishwasher's cycle times may be impacted.

	Heavy	Auto	Normal	Speed60®	Rinse
Cycle time min.	110-130	115 - 130	130 - 135	60	12
Water usage gal/L	5.7-7.3/ 21.5-27.7	3.8-6.5/ 14.4-24.5	3.5-7/ 11.3-21.5	4.5/ 17	1.1/ 4.1
Wash temp. °F/°C	151-160/ 66-71	126-151/ 52-66	122-131/ 50-55	127/ 53	in-coming
Rinse temp. °F/°C	162/ 72	154-162/ 68-72	153-158/ 67-70	158/ 70	in-coming

SpeedPerfect

Cycle time min.	95-110	90-105	95-105	N/A	N/A
Water usage gal/L	4.5-6.7/ 16.9-25.3	3.8-6/ 13.7-21.7	3.2-5.7/ 12.3-21.7	N/A	N/A
Rinse temp. °F/°C	162/ 72	162 72	162/ 72	N/A	N/A

Half Load

Cycle time min.	110	95-115	115-120	N/A	N/A
Water usage gal/L	4.8/ 18.1	2.9-4.6/ 11.1-17.4	2.9-4.3/ 10.9-16.2	N/A	N/A
Rinse temp. °F/°C	162/ 72	162 72	153-158/ 67-70	N/A	N/A

Extra Dry

Cycle time min.	120-140	130-145	150-155	80	N/A
Water usage gal/L	5.7-7.3/ 21.3-27.7	3.8-6.5/ 14.4-24.5	2.9-5.5/ 10.9-20.7	4.5/ 17	N/A
Rinse temp. °F/°C	162/ 72	162/ 72	162/ 72	162/ 72	N/A

	Heavy	Auto	Normal	Speed60®	Rinse
Sanitize					
Cycle time min.	120-140	135-150	135-155	N/A	N/A
Water usage gal/L	5.7-7.3/ 21.3-27.7	3.8-6.5/ 14.4-24.5	2.3-5.5/ 8.8-21.0	N/A	N/A
Rinse temp. °F/°C	162/ 72	162/ 72	162/ 72	N/A	N/A

Note: Only sanitizing cycles have been designed to meet the requirements of Section 6 of the NSF/ANSI Standard for Residential Equipment for soil removal and sanitization efficacy. There is no intention, either directly or indirectly, to imply that all cycles have passed sanitization performance tests.

Operating the Dishwasher

WARNING - RISK OF INJURY! To avoid risk of injury, always use caution when opening the door during or following a wash cycle as hot water or steam may escape. Do not fully open the door until water noises have stopped and steam has subsided.

Protection against unintentional operation

Your dishwasher is equipped with a function that helps to prevent unintentional operation (e.g. by children).

After setting the dishwasher, the dishwasher door has to be closed within 4 seconds, otherwise the operation will be paused. There will be a signal on the control panel advising you to press the Start button again and close the door.

This function will be activated when:

- pressing Start to begin a wash cycle
- setting Delay time and pressing Start
- opening the door while Delay time is active
- opening the door during a wash cycle.

Note: This function cannot be deactivated.

AquaSensor

- The AquaSensor is an optical measuring device which measures the cleanliness of the rinse water.
- The AquaSensor is used according to the wash cycle. If the AquaSensor is active, “clean” rinse water can be transferred to the next rinse and water consumption can be reduced by 0.8–1.5 gal (3–6 liters). If the rinse water is not yet clear, the water is drained and is replaced with fresh water. In the automatic wash cycles the temperature and running time can also be adjusted to the degree of soiling.

Switching the appliance on

1. Turn the water supply on fully.

2. Press the On/Off button 1. The AUTO wash cycle has been preset as a default whenever the appliance starts. This wash cycle remains selected if no other wash cycle button 2 is pressed. Select any desired option.
3. Press Start button 6. Wash cycle sequence starts.

Note: Your dishwasher is protected against unintentional operation. If the appliance door remains open for more than 4 seconds after pressing the Start button, the operation will be paused. Close the appliance door and press the Start button 6 again.

Time display

- When a wash cycle is selected the remaining wash cycle time is shown on the display 3.
- The wash cycle time is determined during the wash cycle by the water temperature, the amount of dishes, as well as the degree of soiling and may vary (depending on the selected wash cycle).

Delay start

You can delay the start of the cycle in one hour increments up to 24 hours.

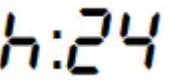
-  1 hour delay
-  24 hours delay

To set Delay start:

1. Press On/Off button 1. Select a cycle.
2. Press Delay button 4 until the displayed time corresponds with your requirements.
3. Press Start button 6 to activate Delay start.

To cancel Delay start:

1. Press Delay button 4 until  is indicated on the digital display 3.
2. Press Start button 6 to save setting.

Note: Your dishwasher is protected against unintentional operation. If the appliance door remains open for more than 4 seconds after pressing the Start button, the operation will be paused. Close the appliance door and press the Start button 6 again.

Wash cycle end

- The wash cycle has ended when the display 3 reads .

Auto power off

This setting determines the length of time the control panel stays illuminated after the cycle is

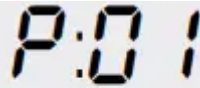

complete. To save energy the recommended setting is

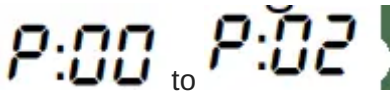

This setting can be adjusted from

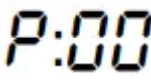
-  dishwasher does not turn off automatically

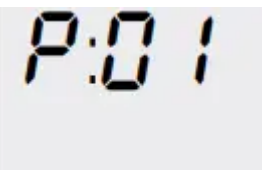
-  dishwasher turns off automatically after 1 minute

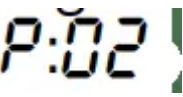
-  dishwasher turns off automatically after 120 minutes (2 hours)

To change the setting:

1. Press the On/Off button 1.
2. Hold down the function key A and press the Start button 6 until the display 3 indicates

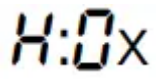
 (x can be any number).

3. Release both buttons.

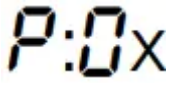
4. Press the function key A until the display 3 indicates 

5. Press the function key 3 until the display corresponds with your requirements.

6. Press the Start button 6.

Switching off the appliance

Short time after the end of the wash cycle:

1. Press On/Off button 1.
2. Remove the utensils when they have cooled down.

WARNING - RISK OF INJURY! To avoid risk of injury, always use caution when opening the door during or following a wash cycle as hot water or steam may escape. Do not fully open the door until water noises have stopped and steam has subsided.

Interrupting the wash cycle

CAUTION: Expansion (overpressure) may cause the appliance door to open and/or water to escape! If the door was opened on an appliance which has a hot water connection or is heated, always leave the door ajar for several minutes and then close.

1. Press On/Off button 1. The LED's go out. The wash cycle is saved.
2. To continue the wash cycle, close the door and press On/Off button 1 again.

Note: Your dishwasher is protected against unintentional operation. If the appliance door remains open for more than 4 seconds after pressing the Start button, the operation will be paused. Close the appliance door and press the Start button 6 again.

Terminating the wash cycle (Reset)

1. Press and hold Start button 6 for approximately 3 seconds until the display reads

0:01

2. Wait about 1 minute while the dishwasher drains.
3. Press On/Off button 1.

You may now power the dishwasher back on and begin a new cycle if desired.

Changing the wash cycle

- When the Start button 1 has been pressed, the wash cycle cannot be changed. The only way a wash cycle can be changed is by terminating the wash cycle (Reset).

Child Lock (panel lock)

The child lock feature will lock the panel while the dishwasher is in operation to prevent a wash cycle from being interrupted unintentionally (e.g. by children).

To set the panel lock:

1. Start the desired wash cycle.
2. Hold down the button labeled with a  symbol or the words 'Child Lock' for

approximately 3 seconds until the display reads **CL**. The panel lock is active.

CL will show in the display if any button is pressed and the program will not be reset.

To deactivate the panel lock, hold down the button again for approximately 3 seconds until the

display no longer reads **CL**

The panel lock is deactivated automatically when the wash cycle ends. In the case of a power outage, the panel lock will remain active. The panel lock has to be activated with each new wash cycle.

Intensive drying

The final rinse uses a higher temperature which improves the drying result. The cycle time and energy usage may be increased. (Caution if utensils are delicate!)

This feature has two settings:



1. Press the On/Off button 1

2.

Hold down function key A and press Start button 6 until the display 3 indicates **H:X** (x can be any number).

3. Release both buttons.

4.

Press function key A until the display 3 indicates the factory set value **d:00**

5.

Press function key C to switch the intensive drying feature on **d:01**, or off

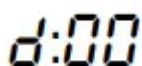

6. Press Start button 6 to save setting.

Care and Maintenance

A regular inspection and maintenance of your machine will help to prevent faults. This saves time and prevents future problems.

Cleaning the dishwasher

- Regularly wipe the front of the appliance with a damp cloth - water and a small amount of liquid soap is adequate.
- For black stainless steel and anti-fingerprint surfaces, use a soft, dry towel. For stubborn dirt, use warm water diluted with a non-abrasive, mild cleansing soap. Never use stainless steel polish.
- For stainless steel appliances (excluding black stainless and anti-fingerprint), use a stainless steel polish to seal and protect the surface.

- Clean the outer edges of the inside door panel regularly to remove debris that may collect from normal loading. If spots begin to appear on the stainless steel, make sure the rinse aid dispenser is full and functioning properly.
- Clean the door seal regularly with a damp cloth to remove food particles that may collect from normal loading and cause odor. A soiled door seal may not seal properly.

NOTICE

- Never use a steam cleaner to clean your dishwasher. The manufacturer is not liable for any resulting damage.
- Do not use sponges as they could scratch the surfaces.
- Do not use bleach-based wipes as they could damage the surface or printing.
- Never use stainless steel polish on a black stainless finish or anti-fingerprint surfaces.

WARNING: Use caution when removing parts for cleaning as some debris may be sharp.

Filters

- The Bosch® filter system 25 is designed to prevent the need to pre-rinse normally attached food soils from your dishes. Simply scrape leftover food soils off of dishware before loading. This process will conserve time, water and the energy require to heat your household water supply.
- Your dishwasher filter system is designed to filter 100% of the water entering the spray arms to provide a continuous supply of clean water to remove food soils from your dishware.

Filter components

The filter system 25 consists of three parts.

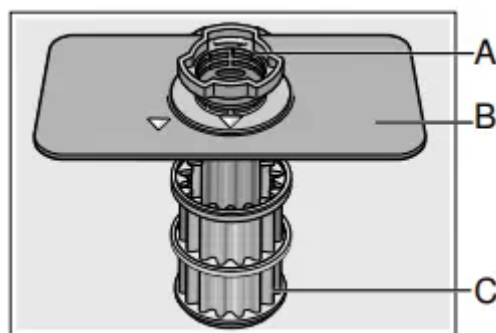

A Large Object Trap Prevents objects that should not be placed in your dishwasher from damaging the dishwasher pump system or clogging your household drain.

B Flat Fine Filter Prevents food particles from entering the wash chamber and directs particles toward the micro filter.

C Micro Filter Directs the smallest of particles to the household plumbing drain.

Cleaning intervals

- The filter system 25 is designed to minimize maintenance while providing premium cleaning performance and minimum energy consumption.
- Depending on use habits and water hardness, the filter system will require some maintenance to sustain premium cleaning performance.
- Your filter system may need to be cleaned when:
 - You notice food soils remaining on the filter system or objects trapped in the Large Object Trap.
 - A drop in cleaning performance or a gritty film forms on the dishware.
- When washing normally attached food soils that have been scraped before loading, in a household that runs the dishwasher every other day, your filter should be cleaned:
 - 3-6 times: a year light to average use
 - 8-12 times: a year heavy use
- Note: Clean the filter system after washing loads with large amounts of food soils or loads with a heavy starch content, like potatoes and pasta, to maintain optimal performance.

To check or clean the filter system:

1. Unscrew the Large Object Trap as illustrated and remove the entire filter system.

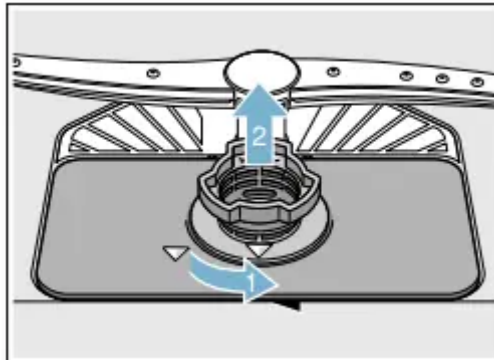

2. Remove the microfilter from the fine filter for easier cleaning.

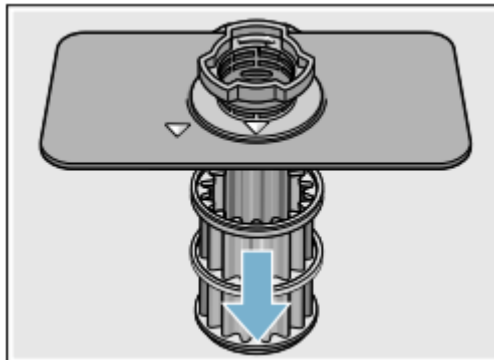

3. Rinse the filters under running water and use a soft brush to clean. Note: do not use abrasive brushes or steel wool, etc., as they may damage the filter.

4. Reinstall the filter system in reverse sequence and lock into place by screwing the Large Object Trap until the marking arrows align.

Spray arms

Check spray arms 21, 24 for grease and limescale deposits. If you find such deposits:

- Fill detergent dispenser 26 with detergent and start the appliance without utensils in the cycle with the highest rinsing temperature. "Wash Cycle Information"
- Clean the appliance with detergents/appliance cleaners which are particularly suitable for use with dishwashers.
- Unscrew the upper spray arm 21 and pull off the lower spray 24 arm as shown. Inspect for deposits.

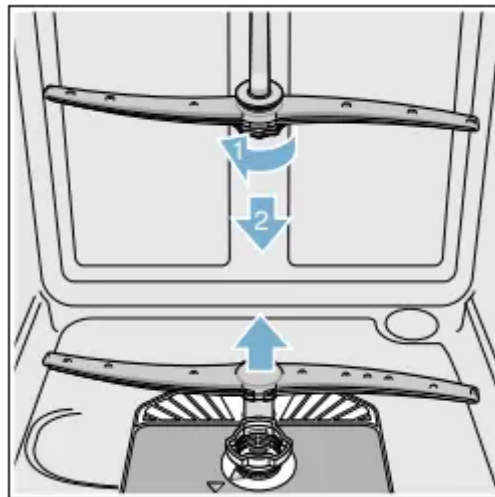

Drain pump

Large food remnants in the rinsing water not retained by the filters may block the waste water pump. In this case:

- Disconnect the appliance from the power supply.
- Remove the filters. ~ "Filters"
- Scoop out standing water - use a sponge if necessary.
- Using a spoon, pry off the pump cover until it clicks, then grip the cover and pull upward until it resists and then pull forward.

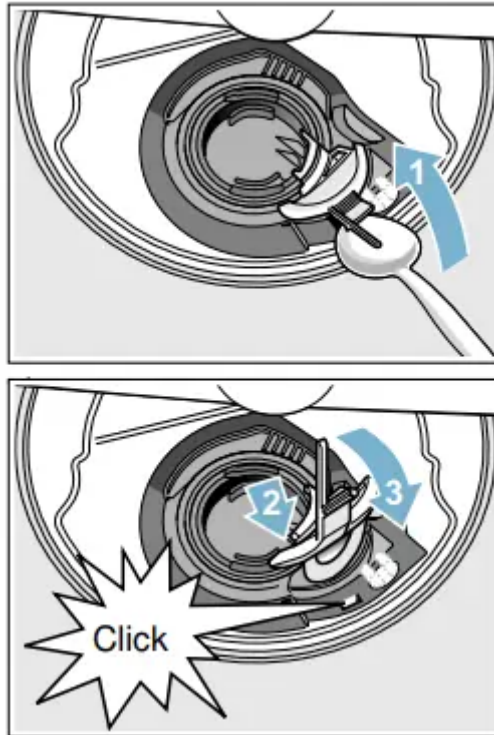

- Check inner compartment and remove any foreign objects.

WARNING: Use caution when removing parts for cleaning as some debris may be sharp.

- Place cover in the original position, press down and engage.
- Reinstall filters

Note: The drain pump will not work properly if the drain pump cover is not snapped in completely until it clicks.

Preparing your unit for vacation

- NOTICE: Before leaving for vacation during warmer weather, besides turning off the main valve, also turn off water supply at the nearest point to the dishwasher. Do not leave soiled dishware in unit and leave door slightly open. During colder weather, please follow the instructions for winterizing your unit below.

Winterizing your unit

- NOTICE: If your dishwasher will be unused for a period of time in a location that experiences freezing temperatures (holiday home or through a vacation period), have your dishwasher winterized by a professional service.

Troubleshooting

Dishwashers may occasionally exhibit problems that are unrelated to a malfunction of the dishwasher itself.

The following information may help you with a dishwasher problem without involving a repair professional.

1. Error code E: 18 is lit.

- Supply hose kinked.
 - Install supply hose without kinks.
- Water supply turned off.
 - Turn on the water supply.
- Water supply line is clogged.
 - Unclog water line.

2. Error code E:22 is lit.

- Water in sump since sump filters 25 are dirty or blocked.
 - Clean filters.

3. Error code E:24 is lit.

- Drain line is clogged.
 - Unclog drain line.
- Drain hose is kinked, clogged or blocked.
 - Replace drain hose.
- Drain pump impeller (vanes) is clogged or blocked.
 - Remove drain pump cover, clean around pump impeller and replace cover.
- Drain pump cover was loose.
 - Lock drain pump cover into place in the sump

4. Error code E:25 is lit.

- Drain pump is blocked or pump cover is loose.
 - Clean drain pump and lock drain pump cover into place in the sump.

5. Error code E:27 is lit

- Supply voltage too low (less than 98 volts).
 - Not a dishwasher fault; have the supply voltage and electrical installation checked.

6. A different error code is indicated on the digital display. (E:01, to E:30)

- A technical fault has probably occurred.
 - Switch off dishwasher with the On/Off switch 1. After a short time restart the dishwasher. If the problem recurs, turn off the tap and pull out the power supply plug. Call customer service and mention the error code.

7. Dishwasher does not start.

- Door may be ajar or not be properly latched.
 - Close door securely until door latch clicks.
- No power to the dishwasher (display won't come on). Fuse may have been blown, circuit breaker may have tripped, power cord may have been unplugged or dishwasher may have been turned off.
 - Replace blown fuse or reset tripped circuit breaker. Plug power cord into outlet securely. Press the on/off button (to turn the dishwasher on.
- Can't select a wash cycle since the previous wash cycle may not have finished or the dishwasher hasn't been reset.
 - Reset the dishwasher by pressing and holding the START button for at least three seconds.
- Delay start or Child lock may be activated.
 - Reset Delay start or Child lock functions (refer to the appropriate section in this manual).
- The door may have been closed without selecting a wash cycle.
 - Select a wash cycle and close the door.
- Water supply may not be turned on or connected.
 - Check and turn on water supply.

8. Wash cycle won't resume after door was opened and closed.

- The door has been open for more than 4 seconds after pressing the Start button.
 - Press Start button again and close the dishwasher door within 4 seconds (see "Protection against unintentional operation" section in this manual).

9. Display does not illuminate.

- A fuse may have been blown or circuit breaker tripped.
 - Check the fuse or circuit breaker box and replace the fuse or reset the breaker if necessary.

- Door not closed or latched. Note: For models with controls on top of the door, the display only illuminates when the door is opened and controls are visible.
 - Ensure door is properly latched and completely closed.

10. Dishwasher runs a long time.

- Incoming water is not warm enough.
 - Before starting a cycle, run hot water faucet at the sink closest to the dishwasher.
- Cycle time depends on wash cycle chosen and amount of soil on dishes (dishwasher sensors increase cycle times to ensure dishes are clean when heavy soil is detected).
 - Scrape food off of dishes and use less intensive wash cycles.
- Rinse aid dispenser 28 is empty, or rinse aid setting = 0. Without rinse aid, wash cycle defaults to longest time with most number of washes and rinses.
 - Add rinse aid and change rinse aid setting depending on water hardness.
- Dishwasher is connected to cold water supply.
 - Connect dishwasher to hot water supply

11. Dishes aren't clean enough

- Spray arms are blocked or misaligned where they cannot rotate freely.
 - Make sure spray arms 21, 24 can rotate freely.
- Little or no water spray due to clogged spray arm nozzle.
 - Clean out spray arm nozzles and filters of all debris and obstructions. ~ "Spray arms"
- Little or no water spray due to clogged or misaligned filters 25.
 - Clean filters and make sure they're installed correctly. ~ "Filter components"
- Dishes are nested or placed too closely together and racks are overfilled.
 - Space dishes apart so spray jets can reach the surface of the dishes and dishes don't contact each other. ~ "Loading the Dishwasher"
- Improper or ineffective wash cycle or detergent used.
 - Choose a more intensive wash cycle and use appropriate dishwasher detergents. ~ "Wash Cycle Information"
- Detergent is made less effective due to hard water.
 - Install a water softener and choose a more intensive wash cycle.

12. Removable spots or streaks on glasses and silverware.

- Too much rinse aid causes streaks and too little rinse aid can cause spots.
 - Add rinse aid and check rinse aid setting (recommended setting 4-5). ~ "Rinse Aid"
- Mineral deposits from hard water.
 - Install a water softener.
- Water from top (3rd) or upper rack dripped on racks below.
 - Unload lower rack 1st, upper rack 2nd and top (3rd) rack last.

13. Dishes not dry.

- Rinse aid dispenser 1b is empty or incorrect rinse aid amount is set.
 - Add rinse aid or adjust setting - the use of rinse agent improves drying, use the Auto cycle, use the Sanitize option.
- Extra Dry heat option not chosen.*
 - Activate Extra Dry heat option.*
- Water collected in depressions on the dishes and silverware.
 - Arrange dishes in upper rack to slope so water can drain.
- Door was opened or dishes removed before wash cycle was completed.
 - Wait until wash cycle ends before opening door or removing dishes.
- Plastics don't absorb heat like cutlery or china and don't dry as well.
 - Use more intensive wash cycles (with hotter rinse water) or activate Extra Dry heat option.*
- Silverware not arranged properly in the silverware basket or top rack.
 - Arrange silverware properly and separate them so they don't contact each other

14. Odor Note: Water testing is done in the factory. Occasionally water may still appear in dishwasher at purchase which may create an odor.

- Food debris in the dishwasher sump and door seal.
 - Clean sump filters, sump and door seal as needed. ~ "Care and Maintenance"
- Food debris left on dishes too long.
 - Run dishwasher more frequently.
- Not using rinse aid or using improper detergent.
 - Use rinse aid and the proper detergent.

- Residual standing water in the sump.
 - Make sure previous wash cycle has finished.
- Drain line is clogged or drain hose is kinked, clogged or blocked. Or drain hose was not installed with a high loop.
 - Unclog drain line or replace drain hose. Be sure drain hose is installed with high-loop. Note: If odor still persists, run the Normal/ Regular cycle until it flushes and interrupt the cycle and place an 8 oz. cup of distilled white vinegar solution on the upper rack and then finish the cycle.

15. Dishwasher isn't filling with water (or "Check water supply" display occurs)

- Water supply hose is kinked.
 - Install new supply hose (without kinks).
- Previous wash cycle was not completed or current wash cycle was interrupted.
 - Complete wash cycle or reset dishwasher.
- Delay start or Child lock may be activated.
 - Reset Delay start or Child lock functions (refer to the appropriate sections in this manual).
- Water supply line is clogged.
 - Unclog water line.
- Water supply was turned off.
 - Turn on water supply

16. Fascia panel is discolored or scratched.

- Panel was cleaned with bleach-based wipes or abrasive cleaners/cleaning pads.
 - Use mild detergents with soft damp cloth.

17. Noise from dishes rattling or water striking tub walls.

- Dishes weren't loaded properly, allowing dishes to hit each other or spray arms.
 - Load dishes properly into racks. ~ "Loading the Dishwasher"
- Light dishes or lightly loaded racks allow dishes to move or water sprays to strike tubs.
 - Load more dishes or distribute dishes more evenly/securely in the dishwasher.

18. Water leaks from tub or from around door.

- Suds from using the wrong detergent (i.e. dish) or overfilling/spilling rinse aid.
 - Use an appropriate dishwasher detergent, don't overfill rinse aid and clean any spilled rinse aid. If suds still persist, add one tablespoon of vegetable oil and run the desired cycle.
- Door seal was misaligned or pulled from its track.
 - Make sure the door seal is securely inserted into its track.
- Condensation vent is blocked.
 - Clean out vent and move tall items like trays away from the vent.
- Improper installation.
 - Have an authorized service professional remount the dishwasher.

19. White limescale on dishes, tub, racks or door.

- White residue coats dishwasher interior and racks wheels squeak from lime scale deposits in hard water.
 - Use a dishwasher cleaner every few months. If dishwasher has a water softener, increase the setting.
- Hard water kept 3 in 1 detergent or Eco detergent from being effective.
 - Use separate dishwasher detergent, rinse aid and dishwasher softener salt (if dishwasher has a softener).
- Under dosing of detergent.
 - Use more detergent or change to a more effective detergent.
- Rinse temperature is too low.
 - Select more intensive wash cycles with higher washing temperatures.

20. Detergent dispenser cover will not shut

- Cover guides are blocked by sticky detergent residue.
 - Remove detergent residue.~ "Detergent"

21. Unable to select desired cycle

- Previous cycle not finished.
 - -> "Operating the Dishwasher"

Warning

This content is compiled from multiple sources and is provided for reference purposes only. It may not be complete or fully applicable to all situations. If you are unable to resolve your issue, please contact the product manufacturer or an authorized service provider for official support.

Document generated by [ManualsFile](#)

