

PARTS IDENTIFICATION



1. Lid
2. Viewing Window
3. Filter Compartment
4. Basket Handle
5. Basket Drain Support
6. Wire Basket
7. Temperature Control Knob
8. Timer Control Knob
9. Control Box
10. Heating Element (underneath baskets)
11. Removable Oil Tank
12. Main Body
13. Power Indicator Light (Green)
14. Temperature Ready Light (Red)
15. Lid Handle
16. Main Body Handle
17. Safety Switch (behind heating element on the control box)
18. Reset Button
19. Power cord Inlet (on the back of Control Box)

Reset Function: your appliance is equipped with safety features. To prevent overheating, the thermal protective device will switch off the fryer automatically. This device is a small reset button found either on the backside or underside of the electrical component, or in the cord storage

compartment. It can be re-activated by pushing the button in again with a toothpick or non-metal object.

**Disconnect from power outlet before resetting.

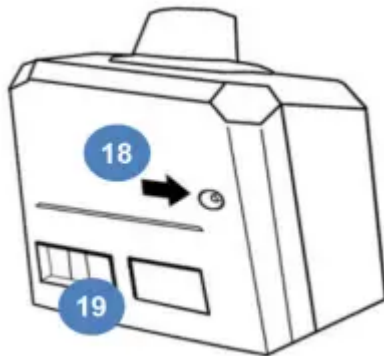

BEFORE FIRST USE

1. Remove all printed documents and packaging materials from the machine.
2. Pull out all removable parts and wash gently with hot water. Dry all parts thoroughly before assembling.
3. Do not operate the fryer without enough oil in the oil tank.
4. The Deep Fryer should always be placed on a flat and stable surface where the power cord is out of reach from children and away from accidental entanglement.

TIPS:

1. When you fry several different kinds of food, always fry the food that uses the lowest temperature setting first.
2. Do not mix different types of oil for frying.
3. Frying already pre-cooked foods may take less time to fry than completely raw food.
4. Replace the oil after each 10-15 uses or earlier if the oil becomes brown and thick.

WARNINGS:

1. THIS DEEP FRYER IS ONLY SUITABLE FOR USE WITH OIL OR LIQUID FAT AND NOT SOLID FAT. IF SOLID FAT IS USED, WATER CAN BECOME TRAPPED INSIDE AND THE HOT FAT MAY SPEW OUT WITH CONSIDERABLE FORCE.
2. Never switch on the deep fryer without oil or liquid fat, as this could damage the machine. Also, do not place any other liquids such as water or other substances in the pan.
3. Place the deep fryer on a dry, stable surface. Since the deep fryer becomes hot during use, make sure that it is not too close to other objects.

NOTE: Do not immerse the Power Cord, Control Box Assembly or Heating Element of the deep fryer into any liquids.

HOW TO USE

ASSEMBLY:

1. Make sure the Deep Fryer is unplugged when assembling.
2. Make sure the temperature control knob is set to the OFF or 0 position.
3. Place main body (11) on a flat, stable surface.
4. Insert oil tank (10) into main body (11).
5. Align grooves of Control Box (8) with grooves found on the main body (11). This will properly engage the small Safety Switch and ensure proper activation. Push down firmly to secure. If Safety Switch is not properly engaged, the unit will not power on.

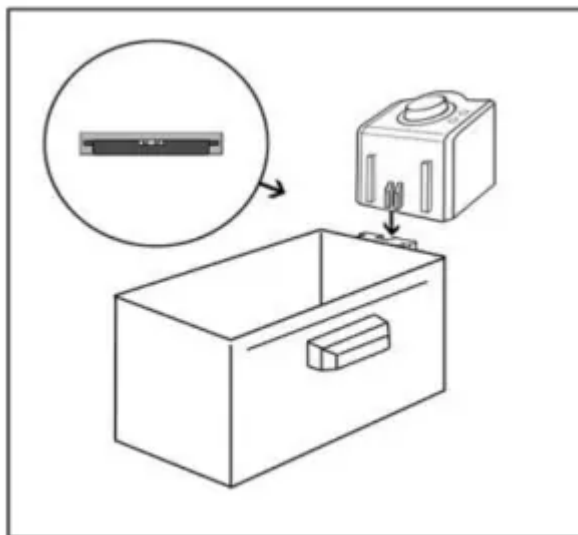

Safety Switch Alignment

MAKE SURE TO ENGAGE THE SAFETY SWITCH:

During assembly, make sure the control box is secured properly to the slots on the back of the body frame. This will properly engage the small safety switch and ensure proper activation. Otherwise the fryer will not power on

6. Fill Oil Tank with oil. For best results we recommend vegetable oil.
 7. To assemble handle (4), squeeze tines of handle together and insert into bracket of the wire basket.
 8. Place wire basket (6) into oil tank (10) and allow it to hang and rest on the backside of the oil tank (10).
- Your new deep fryer comes with 3 frying baskets.

- The two smaller baskets can be used simultaneously if frying multiple foods at once.
- The single larger basket should be used alone to fry larger portions.

MAXIMUM	16 cups / 4 quarts
MINIMUM	14 cups / 3.4 quarts

NOTE:

- The oil level should always be between the MIN and MAX level of the Oil Tank. Do not exceed the maximum fill line as boiling oil may overflow during frying and can cause severe burns.
- Never use different types of oil at the same time as this may cause the oil to overflow.

OPERATION:

1. Attach the magnetic power cord to the inlet on the back of the control box.
2. Plug the power cord into an outlet.
3. Move the Timer knob to the desired time, the power indicator light will turn on green. Timer knob must be set to power on the deep fryer.
4. Move the Thermostat knob to desired temperature setting according to the particular recipe you are using.
5. While the oil is preheating, prepare the food that is going to be fried.
6. When the temperature has been reached, the heat indicator light turns off.
7. When placing the food into the basket, make sure it is as dry as possible. Do not add water, ice or wet food, it may cause HOT OIL SPLATTER.
8. When frying frozen food, clear off any ice particles and thaw food thoroughly.
9. Do not overfill the basket.
10. Lower basket(s) of food into hot oil and cover fryer w/ lid.
11. Remove food after desired cooking time has elapsed. Take care to remove foods before it starts soaking up too much oil.

RESET BUTTON:

- If your deep fryer's heating elements shut off in the middle of frying and does not come back on, unplug the unit and allow it to cool off up to 10-minutes. Re-plug the power cord and power back on.



- If the deep fryer still does not power on or heat up, please locate the 'Reset Button' on the control box. It is located on the BACK of the control box next to the power cord socket.
- The Reset Button is located inside a small hole. Unplug the deep fryer from any power outlet. Use a small thin tool to stick into the small hole to push in on the Reset Button and hold for 3 seconds.
- Re-plug the power cord and power back on.

NOTE:

- During the frying process, the oil temperature may drop when adding new food to be fried, the heat indicator light will periodically turn on and off.
- No matter what the recipe, food must be dried thoroughly before frying. Otherwise, the moisture may cause foaming of the oil and overflowing.

CAUTION: Do not touch the control knob during the frying process. Hot steam may be released and may cause injury

FRYING GUIDE

The frying times given in the chart are only a guide and should be adjusted accordingly to the quantity of food being fried.

FOOD	TEMP (°F)	AMOUNT	TIME (min.)
Cheese (frozen, breaded)	375	2-3 cups	2-4
Chicken (frozen, nuggets)	375	2-3 cups	3-5
Chicken (raw, breaded)	375	3-4 pcs	13-18
Fish fillet (frozen, breaded)	350	3-4 pcs	7-8
Fish fillet (raw, breaded)	325	3-4pcs	3-4
Onion rings (frozen)	375	8-10 rings	4-6
Onion rings (raw)	375	8-10 rings	1 ½-2 ½
French fries (frozen)	375	2-3 cups	8-12
French fries (raw)	370	2-3 cups	3-6
Shrimp (frozen, breaded)	375	8-10 pcs	5-7
Shrimp (raw, breaded)	375	8-10 pcs	3-5



AFTER THE FOOD IS FRIED:

1. Make sure to turn the temperature and timer control knobs to the 'OFF' position and unplug the deep fryer.
2. Once food is done cooking, remove the lid, and hang the basket(s) on the hook and let any excess oil drip into the oil pot.
3. Remove the basket(s) and place the food on paper towels to absorb excess oil. Do not touch the basket(s) while still hot. Always use the handle.
4. Transfer food to a clean dish without the paper towels.
5. Place the basket(s) into the deep fryer.
6. If you are frying more than one batch, ensure the oil re-heats to the required temperature.
7. When frying is complete, turn controls to OFF position.
8. Disconnect the power cord. Allow the machine and the oil to cool completely before attempting to move or clean.

PLASTIC LID:

- When your deep fryer reaches high temperatures and the plastic lid is left on your deep fryer for a prolonged period of time, this may result in slight warping of the shape of the lid.
- Once the temperature has cooled down, the lid should reshape itself back to its original form.
- It is recommended to not leave the plastic lid on the deep fryer during operation for any longer than 10-minutes at a time.

CAUTION: Removing the lid will release hot steam. Take extreme care when handling. Keep face and bare skin clear of the steam release.

CLEANING & MAINTENANCE

1. Remove the lid and baskets.
2. Wait for the fryer to cool, lift out the Control Box Assembly & Heating element.
3. Remove the oil pot and pour out the oil. It is recommended to filter the oil after each use if you are to re-use the oil.
4. After removing the oil pot, the fryer can be divided into separate components to clean.
5. The oil pot and main body can be immersed in water to clean.

6. Do not use abrasive scrubbing brushes or chemical cleaners to clean the unit. The Control Box & Heating Element should be wiped clean with absorbent paper towels. Then use a damp cloth and a mild soap to clean.
7. Dry all parts thoroughly.

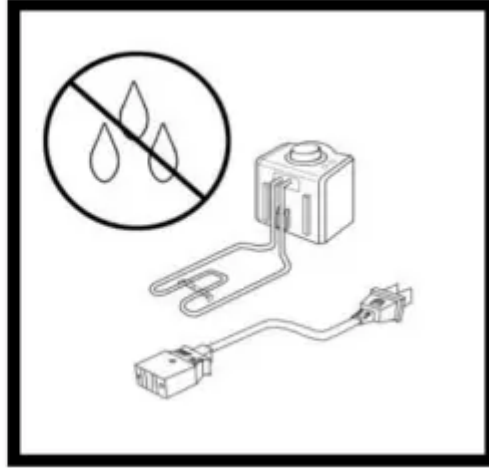

HOW TO REPLACE THE FILTERS:

Your carbon filter (black piece) should be changed every 6 months. The oil filter (white piece) should be changed every 12 months.

1. Unclip and remove the filter cover.
2. Take out both white and black filter pieces.
3. Throw out old filters and replace with new filters. Make sure the White filter piece rests on the metal surface BELOW the carbon filter (black piece).

STORING YOUR DEEP FRYER:

Always allow the appliance to cool completely before storing. Store the appliance in a dry location. Keep the power cord out of reach of children.

CAUTION:

- Before cleaning the deep fryer, make sure that it is disconnected from the power outlet, make sure the unit and the oil have completely cooled. Oil retains its temperature for a long period after use. Do not attempt to carry or move the deep fryer while the oil is hot.
- NEVER immerse the Control Box & Heating Element into water to clean.

NOTE:

Filters can be gently rinsed in warm soapy water as well and reused again. But it will need to be replaced after considerable use.

IMPORTANT SAFEGUARDS

The Elite Brand takes consumer safety very seriously. Products are designed and manufactured with our valued consumers' safety in mind. Additionally, we ask that you exercise a level of caution when using any electrical appliance by following all instructions and important safeguards.

READ ALL INSTRUCTIONS BEFORE USE AND SAVE FOR FUTURE REFERENCE.

WARNING: When using electrical appliances, basic safety precautions should always be followed as below:

1. Do not touch hot surfaces. Use handles or knobs if applicable.
2. This appliance produces heat. Do not use appliance on any surface that may be sensitive to heat damage.
3. Remove all packaging plastics and other materials from unit before using.
4. Wash all removable accessories before using for the first time.
5. To protect against electrical shock, do not immerse cord, plug or appliance itself in water or other liquids.
6. Close supervision is necessary when appliance is used by or near children.
7. Unplug from outlet when not in use and before cleaning. Allow to cool before putting on or taking off parts.
8. Do not operate any appliance with a damaged cord or plug or after the appliance malfunctions or has been damaged in any manner. Return the appliance to the nearest authorized service facility for examination, repair or adjustment.
9. The use of accessory attachments not recommended by the appliance manufacturer may cause injuries.
10. Do not place the following materials in the unit: paper, plastic cardboard, or similar non-food materials.
11. Some countertop and table surfaces, such as Corian®, wood, stone and/or laminates, are not designed to withstand prolonged heat generated by certain appliances. It is recommended by countertop manufacturers and Maxi-Matic that a hot pad or trivet be placed under your Elite deep fryer to prevent possible damage to the surface.
12. Do not use outdoors.
13. Do not let cord hang over edge of table or counter or touch hot surfaces.
14. Do not place on or near a hot gas or electric burner, or in a heated oven.
15. Always attach plug to appliance first, then plug cord into wall outlet. To disconnect, turn control(s) to OFF position, then remove plug from wall outlet.
16. Oversized foods or metal utensils must not be inserted in the appliance as they may cause a fire or risk of electrical shock.

17. A fire may occur if the appliance is covered or touching flammable material including curtains, draperies, walls and the like when in operation.
18. Do not clean with metal scouring pads. Pieces can break off the pad and touch electrical parts, involving a risk of electrical shock.
19. Extreme caution should be exercised when using containers constructed of a material other than metal or glass.
20. Always place the deep fryer on a stable surface and keep all flammable materials away from the unit during operation.
21. Make sure that the deep fryer is never near or on a switched-on stove or cooking surface.
22. Before you use the deep fryer it must be filled with the required amount of oil or fat.
**Never use the deep fryer without oil or fat because this could damage the unit.
23. Be sure not to damage the heating element. Do not bend or dent.
24. If the deep fryer and/or cord are damaged, they must be repaired by a professional service department. Do not try to repair the unit yourself or replace the damaged cord. This requires special tools. Always contact our Customer Service Department for replacement parts.
25. The electrical component is equipped with a safety heat switch, which ensures that the heating element can only function when the element is correctly placed on the fryer.
26. The oil level must always be between the MIN and MAX markings.
27. If the fryer has a removable pot, never remove it while the deep fryer is on.
28. The cooking times are given as guidelines only.
29. The oil must be filtered regularly and changed after 8 to 12 uses.
30. If you use solid vegetable shortening, cut it into pieces and melt it over slow heat in a separate pot beforehand, then slowly pour it into the deep fryer pot. Never pour shortening directly into the deep fryer pot or basket as this will lead to deterioration of the appliance.
31. Before you use the deep fryer it must be filled with the required amount of oil or fat.
**Never use the deep fryer without oil or fat because this could damage the unit.
32. Do not overload the basket. For safety reasons never exceed the maximum quantity.
33. Never move the deep fryer during use. The oil becomes very hot. Wait until the unit and the oil has completely cooled down before moving.
34. This deep fryer is protected with a thermal safety device which switches the machine off automatically if it over heats.
35. Extreme caution must be used when moving fryer containing hot oil. Be sure handles are properly assembled to basket and locked in place. See detailed assembly instructions.

36. Never immerse the appliance in water.
37. Never leave the deep fryer unattended while in use.
38. Always ensure the safety of children if they are near the deep fryer.
39. In the case of overheating, the thermal protective device will switch off the fryer automatically. This device is a small reset button found either on the underside of the electrical component, or in the cord storage compartment. It can be re-activated by pushing the button in again with a pointed object (e.g. a pen).

****Disconnect from power outlet before resetting!**

SHORT CORD PURPOSE

Note: A short power cord is provided to reduce the risk of personal injury resulting from becoming entangled in or tripping over a long cord.

Longer power-supply cords or extension cords are available and may be used if care is exercised in their use.

If an extension cord is used: (1) the marked electrical rating of the extension cord should be at least as great as the electrical rating of the product; (2) the extension cord should be arranged so that it will not drape over the counter top or tabletop where it can unintentionally be pulled on or tripped over by children or pets.

POLARIZED PLUG

If this appliance is equipped with a polarized plug (one blade is wider than the other), please follow the below instructions:

To reduce the risk of electrical shock, this plug is intended to fit into a polarized outlet only one way. If you are unable to fit the plug into the electrical outlet, try reversing the plug.

If the plug still does not fit, contact a qualified electrician. Never use the plug with an extension cord unless the plug can be fully inserted into the extension cord. Do not alter the plug of the product or any extension cord being used with this product. Do not attempt to defeat the safety purpose of the polarized plug.

Warning

This content is compiled from multiple sources and is provided for reference purposes only. It may not be complete or fully applicable to all situations. If you are unable to resolve your issue, please contact the product manufacturer or an authorized service provider for official support.

