

User Guide Digital Food Dehydrator

Parts and Features

BEFORE FIRST USE: Wash all removable parts in hot, soapy water. Rinse and dry

***To order parts:** US: 1.800.851.8900

Canada: 1.800.267.2826

Mexico: 01 800 71 16 100

How to Load Trays and Screens

Dehydrator Preparation

- The top tray must always be in the top position for proper drying.
- All five trays should be used during each drying, even if some are empty.
- It is best to dry one type of similar food at a time; for example, all fruits or all vegetables.
- Always leave trays in place until drying is complete. You may remove food from trays when acceptably dried.

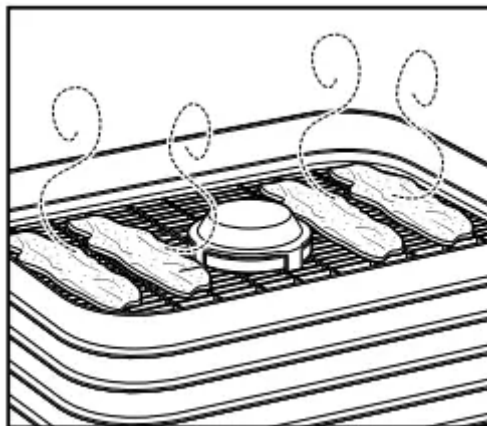

Always place food in a single layer on each tray for even drying. Do not overlap fruits, vegetables, or meats or crowd trays.

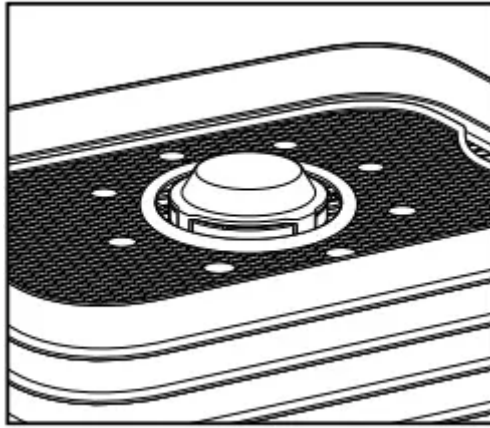

Use the mesh screen for drying herbs and small pieces of fruits or vegetables.

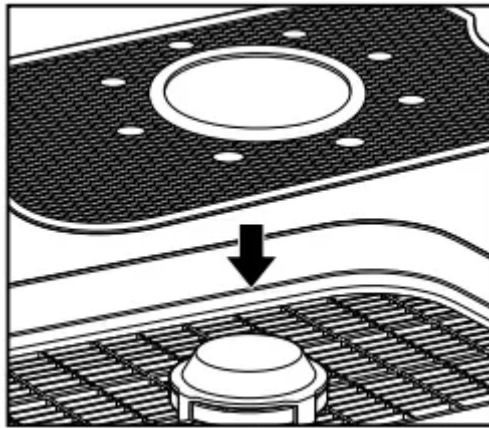

If using a mesh screen, place screen in tray before adding food. For best results, only use mesh screens in the top two trays.

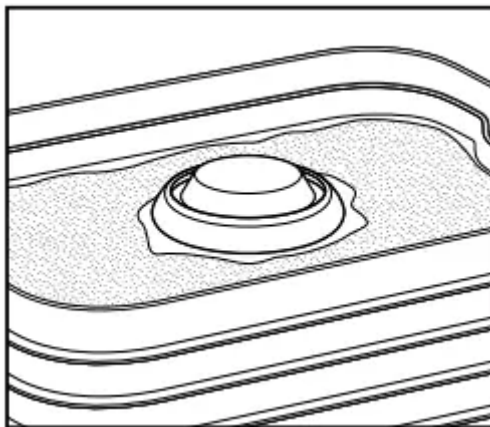

Use the fruit roll sheet for drying purees from fruits.

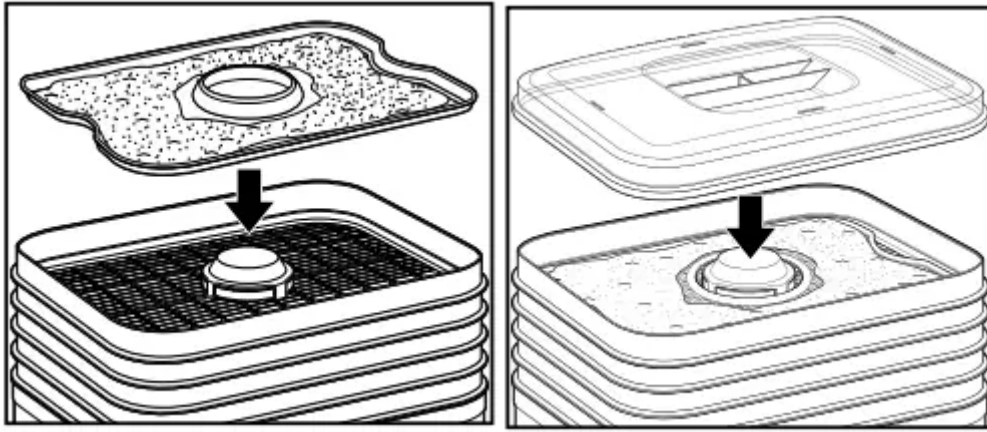

If using the fruit roll sheet, place sheet in the top tray. For best results, do not use more than two fruit roll sheets and place in the top two trays. Always stack the top tray last, before the lid, for proper drying.

How to Use the Dehydrator

NOTES:

- Food should be stored in an airtight container once properly cooled.
- To START, PAUSE, or RESET: Press the START/PAUSE button.
- To Change Time or Temperature During Drying Without Pausing or Resetting: Press the TIME/TEMP button once for time or twice for temperature. The last setting will flash. Use arrows to adjust. Unit will continue drying automatically at the new setting

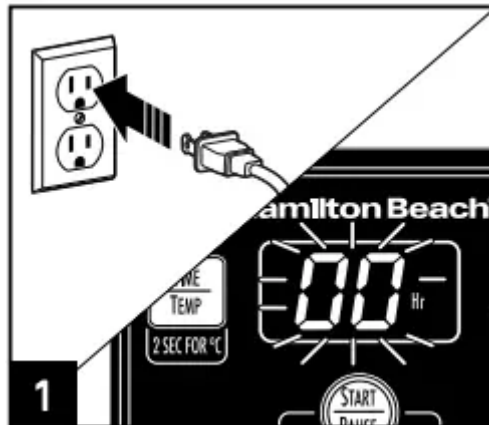

Plug in unit. Default time "00" will flash on the display.

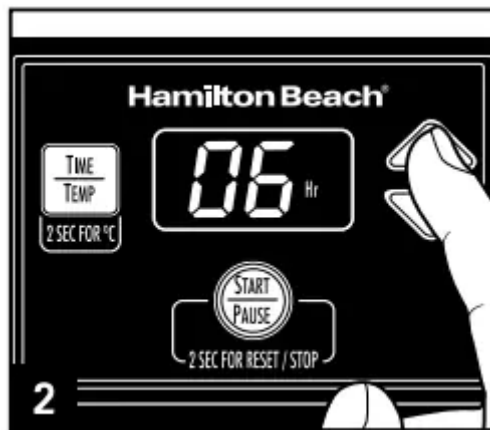

Press the + arrow to set the drying time. Maximum drying time is 48 hours, which can be set in 1-hour increments.



Press the TIME/TEMP button to set the temperature. Default temperature "130" will flash on the display.



Press the + or – arrow to set the drying temperature. Press the TIME/TEMP button to adjust the temperature for Fahrenheit. Press and hold the TIME/TEMP button for 2 seconds while TEMP is displayed to change from °F to °C. Temperature can be set from 100°F to 160°F in 5° increments.

NOTE: Default setting is Fahrenheit. If you reset this unit or unplug it while it is set for Celsius, it will go back to Fahrenheit.

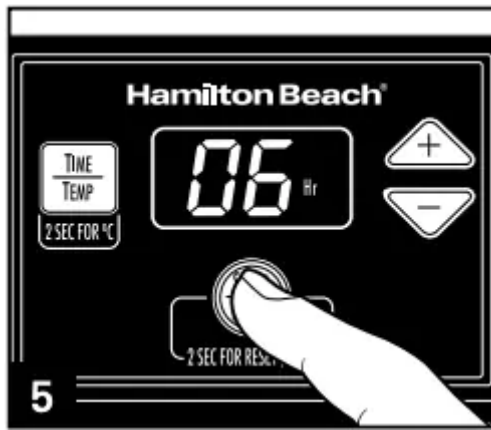

Press the START/PAUSE button to start drying. The display will alternate from showing TIME and TEMP over the drying period.



To PAUSE to Check Food: Press the START/PAUSE button and unit will pause. Display will flash “PA.” Press the START/PAUSE button again to resume drying.



To RESET: Press and hold the START/ PAUSE button for 2 seconds; “00” will flash in display. To continue drying, press TIME/TEMP button to set a new time and temperature.

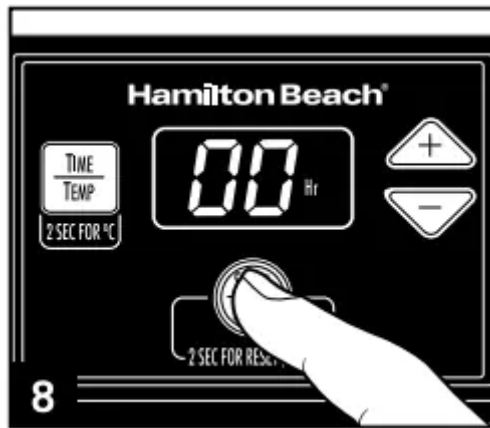

To STOP “00” flashing: Press and hold the START/PAUSE button again for an additional 2 seconds. “00” will still appear in display and not flash. If drying is complete, unplug the unit.

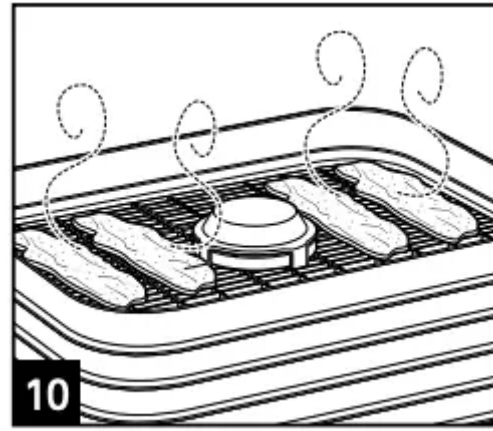
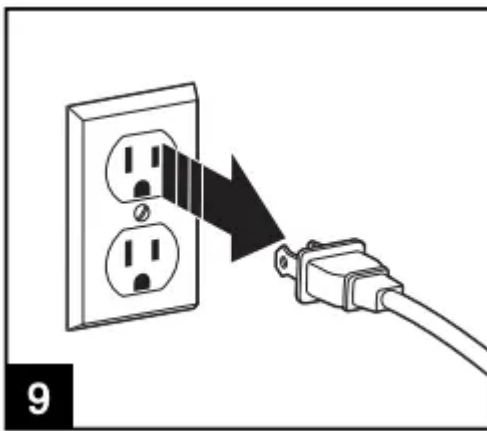

If drying is complete before programmed time has ended, PAUSE or STOP unit and then unplug. Let food cool completely on trays or wire rack before storing.

Food Safety Tips

- For food safety, to help ensure any bacteria present are destroyed, choose pretreatment or post treatment from below:
- Pretreatment of Meat Prior to Dehydrating – Heat oven to 350°F (177°C). Drain and discard marinade from meat. Pat dry with paper towels and place meat in a single layer, leaving a space around each piece on baking sheet. Bake 5 to 10 minutes or until internal temperature reaches 160°F (72°C). Poultry must reach 165°F (74°C).

NOTE: This method may reduce drying time and may result in a drier texture.

- Post Treatment of Meat After Dehydrating – Heat oven to 275°F (135°C). Line a large baking sheet with foil. Place jerky in a single layer, leaving a small space around each piece. Bake for 10 to 12 minutes. Cool completely on a wire rack. Pat jerky dry with paper towels to remove any surface fats before storing.

- Marinating meats helps with the flavor and texture of jerky. Do not marinate meat longer than recipe or package directions call for.

TIP: Post treatment of meat after dehydrating may result in a more desirable jerky texture. Try each treatment to determine which jerky you like best.

- Visit usda for any questions on meat and food safety.
- Never dehydrate meats with fruits and vegetables, due to crosscontamination of foods. Meats dry at a different temperature from fruits or vegetables.
- All dehydrated foods must be cooled completely before storing.
- For food safety, complete the food drying process. Do not start and stop the process for longer than 5 minutes. You may pause the process to check on the food's dryness or to remove dehydrated pieces.
- Label and date all containers of dried foods.

Dehydrating Fruits and Vegetables

A. Food Preparation

- Always wash hands before starting food preparation.
- Wash all fruits and vegetables before preparation.
- Choose fruits and vegetables that are in season for the best flavor.
- Discard any fruits and vegetables that have bruises or mold.
- Cut foods the same thickness, size, or shape before drying to ensure even drying.
- Some foods, like garlic, onions, cauliflower, and broccoli, have a strong smell when drying.

B. Pretreatment

- Some fruits and vegetables require pretreatment before drying. Blanch or add color protectors to preserve natural color.

How to Blanch (see *B on pages 10 and 11)

Blanching is recommended for some vegetables to help prevent color and flavor loss during drying and storage. Blanching is used to break the skins on some fruits to help shorten the drying process.

- Bring a large stockpot filled with cold water to a rolling boil.
- Place cleaned fruits or vegetables in a strainer with a handle.
- Dip strainer into the boiling water for the recommended time.
- Make sure that all the fruits or vegetables are covered with water for even blanching.

- After blanching is complete, plunge into a large bowl filled with ice water to stop the blanching process.
- Drain and completely pat dry the fruits or vegetables before dehydrating.

How to Protect Color (see #C on page 10)

Some fruits and potatoes may discolor during the drying process. To protect the color, follow these steps.

- Prepare a solution of equal parts lemon juice and water.
- Dip pieces into the solution; drain.
- If using a commercial fruit preservative, follow package directions.

C. Determining Dryness

- Many things influence drying time, including moisture content, type and amount of food, shape and evenness of food slices, air temperature, humidity, and your personal preference in texture of your food.
- Drying charts are a guideline. Drying times and temperatures vary for different types of foods; start checking food at the minimum recommended time referenced on the chart. If the food is not listed on the chart, pick a similar food.
- Combine any remaining food to upper trays for ease of checking doneness.
- Check all trays for doneness at the minimum recommended time on the chart.
 - All fruits should be able to bend and be slightly soft but not be tacky, except for apples and bananas which should be crisp.
 - All vegetables should be crisp and easily broken.

D. Drying Fruit Rolls

- Fruit rolls can be made with peeled and pitted pureed fresh fruits; canned fruit that has been well drained and pureed; defrosted frozen fruit, drained and pureed; or with store-bought applesauce.
- Fruits that are higher in pectin (apples, apricots, blueberries, grapes, peaches, pears, pineapples, and plums) will make a fruit roll with a nice leatherlike texture.
- When using a low-pectin fruit (grapefruits, lemons, limes, oranges, raspberries, and strawberries), combine with a higher-pectin fruit for an easy peelable fruit roll.
- Lightly spray the fruit roll sheet with nonstick cooking spray or lightly grease with vegetable oil before adding your pureed fruit.
- Evenly spread about 3/4 cup to 1 cup (177 ml to 237 ml) puree on the prepared fruit roll sheet about 1/4 inch (0.6 cm) thick.
- Add the fruit roll sheet to one of the top two trays for drying.

- Fruit rolls should be checked for doneness starting at 4 hours.
- Fruit rolls will be slightly tacky when dried.
- Always remove the fruit roll from the sheet after cooling for 15 minutes.
- The fruit roll should be slightly warm to easily remove from the fruit roll sheet.
- Once rolled up, cool completely before storing in an airtight container.

Storing Dehydrated Food

- Dehydrated foods have to be cooled completely before packaging.
- Properly dried foods need to be stored in a clean, dry, airtight container, such as resealable plastic bags, plastic containers, or glass canning jars with a tight-fitting lid, to keep foods from rehydrating.
- Store all packages in a cool, dry place.
- Dried fruits stored at 60°F (16°C) may keep up to 1 year, while vegetables stored at 60°F (16°C) may keep up to 6 months.
- Fruit rolls stored at room temperature may keep up to 1 month, if stored properly.
- If jerky has been properly dried, cooled, and packaged, it may be stored up to 2 months in an airtight container at room temperature.
- Storing at higher temperature locations will shorten the storing time. Place packaged foods in the freezer for a longer storing time.
- It is a good practice to check dehydrated foods daily. Dehydrate again if you see fruits and vegetables getting soft or if they have condensation on them. Check frequently during the additional drying, since this process will be much shorter.
- Always check the condition of your food prior to consumption. When in doubt, throw it out.

Dehydrating Chart for Fruits at 135°F (60°C)

*B = Blanching #C = Color Protector (See "How to Blanch" and "How to Protect Color" on page 8)

Fruit	How to Prepare	Pretreatment/Time	Dehydrating Time**	High-Pectin Fruit
Apples	Peeled, sliced 1/4 inch (0.6 cm) thick	#C	8 to 12 hours	Yes
Apricots	Pitted, peeled, sliced 1/4 inch (0.6 cm) thick	#C	15 to 19 hours	Yes
Bananas	Sliced 1/4 inch (0.6 cm) thick	#C	6 to 10 hours	No
Blueberries	Whole	*B/1 minute	14 to 18 hours	Yes
Cherries	Pitted, halved	-	22 to 26 hours	No
Cranberries	Whole	*B/1 minute	17 to 21 hours	Yes
Green or Red Seedless Grapes	Halved	-	19 to 23 hours	Yes
Kiwi	Sliced 1/4 inch (0.6 cm) thick	-	8 to 12 hours	Yes
Lemons, Limes, or Oranges	Sliced 1/4 inch (0.6 cm) thick	-	17 to 21 hours	No
Mangoes	Peeled, pitted, sliced 1/4 inch (0.6 cm) thick	-	13 to 17 hours	No
Nectarines	Peeled, pitted, sliced 1/4 inch (0.6 cm) thick	#C	11 to 15 hours	Yes
Peaches	Peeled, sliced 1/4 inch (0.6 cm) thick	#C	11 to 15 hours	Yes
Pears	Peeled, sliced 1/4 inch (0.6 cm) thick	#C	10 to 14 hours	Yes
Pineapples	Peeled, cored, sliced 1/4 inch (0.6 cm) thick	-	12 to 16 hours	Yes
Plums	Pitted, sliced in eighths	-	23 to 27 hours	Yes
Strawberries	Sliced 1/4 inch (0.6 cm) thick	-	6 to 10 hours	No

**Times may vary depending on the ripeness of your fruits and amount per tray. See "Dehydrating Fruits and Vegetables" on pages 8 and 9.

Dehydrating Chart for Vegetables at 125°F (55°C)

*B = Blanching (See "How to Blanch" on page 8)

Vegetable	How to Prepare	Pretreatment/Time	Dehydrating Time**
Bell Peppers	Sliced 1/4 inch (0.6 cm) thick	-	9 to 13 hours
Broccoli	Small florets	*B/2 minutes	9 to 13 hours
Carrots	Sliced diagonally 1/4 inch (0.6 cm) thick	*B/2 minutes	11 to 15 hours
Cauliflower	Small florets	*B/2 minutes	8 to 12 hours
Celery	Sliced diagonally 1/4 inch (0.6 cm) thick	-	5 to 9 hours
Grape Tomatoes	Halved	-	13 to 17 hours
Green Beans	Sliced 1/4 inch (0.6 cm) thick	*B/2 minutes	12 to 16 hours
Mushrooms	Sliced 1/4 inch (0.6 cm) thick	-	8 to 12 hours
Onions	Sliced 1/4 inch (0.6 cm) thick	-	14 to 18 hours
Squash, Yellow or Zucchini	Sliced 1/4 inch (0.6 cm) thick	-	7 to 11 hours
Tomatoes	Sliced 1/4 inch (0.6 cm) thick	-	10 to 13 hours

**Times may vary depending on the water content of your vegetables.

Dehydrating Fresh Herbs

- Herb leaves that are larger such as basil, bay leaves, mint, sage, or sorrel should be picked from the stems before drying.
- Herbs such as cilantro, dill, parsley, or rosemary should be kept on the stem for drying. It is easier to remove the herbs after drying.

- Always rinse herbs with cold water and carefully remove any remaining water with a salad spinner or paper towels. Herbs must be completely dried before dehydrating begins.
- Small herbs should be placed on the mesh screen for the best drying.
- Herbs are fast-drying when compared to fruits, vegetables, and marinated meats.
- Herbs crumble easily when dried.
- Herbs must be cooled completely before storing in an airtight container.

Dehydrating Chart for Herbs at 100°F (40°C)

Fresh Herb	Dehydrating Time**
Basil	4 to 6 hours
Chives	5 to 7 hours
Cilantro	4 to 6 hours
Mint	5 to 7 hours
Parsley	4 to 6 hours
Rosemary	5 to 7 hours

**Times may vary depending on the water content of your herbs.

Dehydrating Jerky

- Wash your hands with soap and warm water before preparation of jerky.
- Choose lean cuts of meat for jerky.
- Trim any fat from meat before marinating.
- Wrap meat in plastic wrap and freeze for a minimum of 1 hour for easy slicing before marinating.
- Marinate in a heavy-duty resealable plastic zipper bag or a glass dish. Do not use a metal pan for marinating, since it causes a flavor change and a possible reaction of the marinade to the metal of the pan.
- Always marinate meats for jerky in a refrigerator; drain and discard marinade before drying.
- Dehydrate jerky according to the recipe or follow jerky preparation according to package directions.
- Check jerky after 4 hours and every 30 minutes after.
- Jerky is dry when it cracks without breaking when bent.

- Pat jerky dry with a paper towel to remove any surface fats and cool completely before storing in an airtight container.
- If jerky has been properly dried, cooled, and packaged, it may be stored up to 2 months in an airtight container at room temperature.
- Always slice meats against the grain for a more tender jerky.
- Meat slices should be no more than 1/4 inch (0.6 cm) thick, 10 inches (10.2 cm) long and 2 inches (5.1 cm) wide.
- Never marinate meat at room temperature. Always refrigerate meat when marinating.
- Always follow the recipe directions.
- Label and date all containers of jerky.

NOTE: For food safety, to help ensure any bacteria present are destroyed, choose pretreatment or post treatment from below:

- Pretreatment of Meat Prior to Dehydrating – Heat oven to 350°F (177°C). Drain and discard marinade from meat. Pat dry with paper towels and place meat in a single layer, leaving a space around each piece on baking sheet. Bake 5 to 10 minutes or until internal temperature reaches 160°F (72°C). Poultry must reach 165°F (74°C). NOTE: This method may reduce drying time and may result in a drier texture.
- Post Treatment of Meat After Dehydrating – Heat oven to 275°F (135°C). Line a large baking sheet with foil. Place jerky in a single layer, leaving a small space around each piece. Bake for 10 to 12 minutes. Cool completely on a wire rack. Pat jerky dry with paper towels to remove any surface fats before storing.

Care and Cleaning

⚠ WARNING **Electrical Shock Hazard:** Disconnect power before cleaning. Do not immerse cord, plug, or base in water or other liquid.

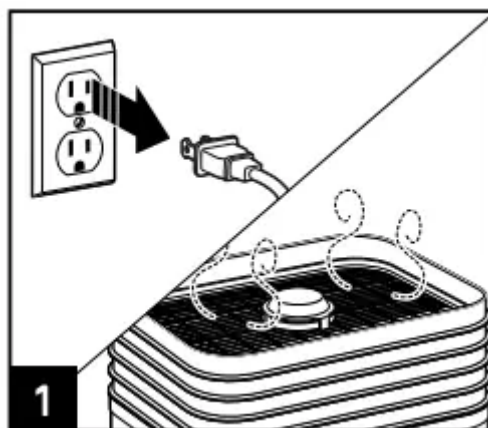

Unplug unit when through drying. Let cool.

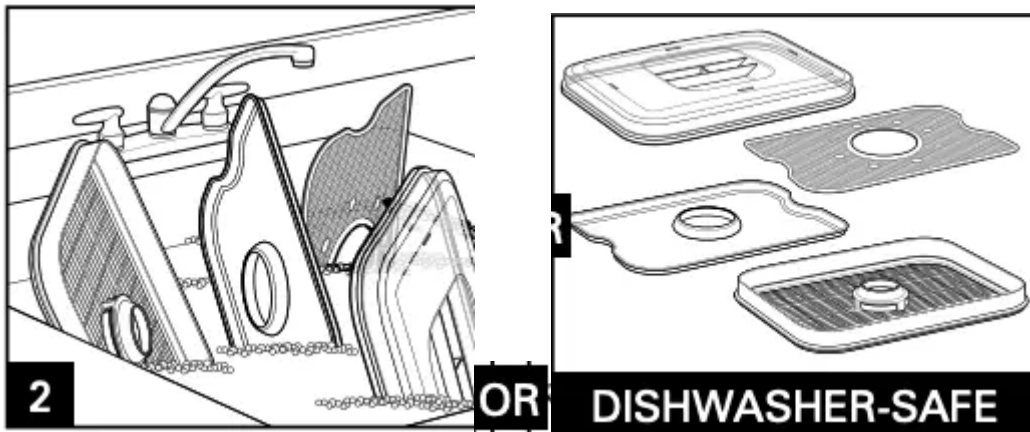

Wash in warm, soapy water.

DO NOT use the “SANI” setting when washing in the dishwasher. “SANI” cycle temperatures could damage your product.

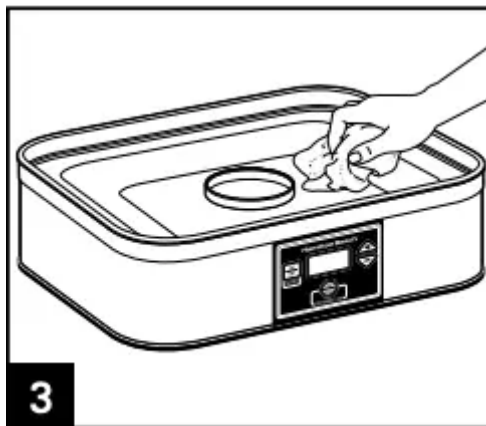

Wipe the base with a damp, soapy cloth.

Troubleshooting

Food not drying.

- Food could be cut too thick or peel could have been left on. Follow recommendations in charts on pages 10, or 12, or according to the recipe.
- Too much food on each tray. Remove some foods and dehydrate for a longer time.

Food drying unevenly.

- Foods need to be cut uniformly.
- Foods with uneven pieces can be rotated during the drying process.

Fruits or vegetables become soft during storage.

- Too much moisture was left in the food. Dry further to remove excess moisture.

Recipes

Whiskey Beef Jerky

Ingredients:

- 2 pounds (907 g) beef top round
- 2 cups (473 ml) root beer
- 1 cup (237 ml) whiskey
- 1/2 cup (118 ml) molasses
- 1/2 cup (118 ml) brown sugar
- 1/2 cup (118 ml) soy sauce
- 2 Tablespoons (30 ml) liquid smoke
- 1 Tablespoon (15 ml) garlic powder
- 1 Tablespoon (15 ml) chili powder

Directions:

1. Place beef in a resealable plastic freezer bag and freeze for 1 hour or until firm enough to slice easily.
2. In a medium bowl, mix remaining ingredients until brown sugar is dissolved.
3. Remove beef from freezer and slice against the grain into 1/4-inch-thick (0.6-cm) slices.
4. Add beef and marinade to bag, making sure meat is completely covered with marinade.
5. Close bag and refrigerate 8 to 12 hours.
6. Drain and discard marinade. Pat all slices of beef with paper towels.
7. Place beef slices in a single layer on the first tray, leaving space around each slice for proper drying. Fill trays with remaining beef slices.
8. Stack trays on base with the top tray last.
9. Set the dehydrator to 160°F (70°C) for 4 to 8 hours. Start checking beef for doneness at 4 hours and then every 30 minutes. Jerky is dry when you can bend it and the top cracks, but the slice does not break.
10. Heat oven to 275°F (135°C).
11. Line a large cookie sheet with aluminum foil. Place jerky in a single layer, leaving a small space around each slice.
12. Bake for 10 to 12 minutes. Cool completely on a wire rack. Pat dry with paper towels before storing in an airtight container.

Makes: About 1 pound

Cajun Beef Jerky

Ingredients:

- 3 pounds (1.4 kg) beef top round
- 3/4 cup (177 ml) Worcestershire sauce
- 1/2 cup (118 ml) water
- 1/2 cup (118 ml) soy sauce
- 1/3 cup (79 ml) teriyaki sauce
- 1 Tablespoon (15 ml) onion powder
- 1 Tablespoon (15 ml) Old Bay® Seasoning
- 1 Tablespoon (15 ml) liquid smoke
- 2 teaspoons (10 ml) Cajun seasoning
- 1 teaspoon (5 ml) celery seed

Directions:

1. Place beef in a resealable plastic freezer bag and freeze for 1 hour or until firm enough to slice easily.
2. In a medium bowl, mix remaining ingredients.
3. Remove beef from freezer and slice against the grain into inch-thick (0.6-cm) slices.
4. Divide beef and marinade between 2 bags, making sure meat is completely covered with marinade.
5. Close bag and refrigerate 8 to 12 hours.
6. Drain and discard marinade. Pat all slices of beef with paper towels.
7. Place beef slices in a single layer on the first tray, leaving space around each slice for proper drying. Fill trays with remaining beef slices.
8. Stack trays on base with the top tray last.
9. Set the dehydrator to 160°F (70°C) for 4 to 8 hours. Start checking beef for doneness at 4 hours and then every 30 minutes. Jerky is dry when you can bend it and the top cracks, but the slice does not break.
10. Heat oven to 275°F (135°C).
11. Line a large cookie sheet with aluminum foil. Place jerky in a single layer, leaving a small space around each slice.
12. Bake for 10 to 12 minutes. Cool completely on a wire rack. Pat dry with paper towels before storing in an airtight container.

Makes: About 1 1/2 pounds

Teriyaki Beef Jerky

Ingredients:

- 2 pounds (907 g) flank steak
- 2 cups (473 ml) pineapple juice
- 1 bottle (15 ounces/444 ml) soy sauce
- 1 1/2 cups (355 ml) packed light brown sugar
- 1 cup (237 ml) rice vinegar
- 6 large garlic cloves, halved
- 2 small dried red chilis, halved

Directions:

1. Place beef in a resealable plastic freezer bag and freeze for 1 hour or until firm enough to slice easily.
2. In a medium bowl, mix remaining ingredients until brown sugar is dissolved.
3. Remove beef from freezer and slice against the grain into inch-thick (0.6-cm) slices.
4. Add beef and marinade to bag, making sure meat is completely covered with marinade.
5. Close bag and refrigerate 8 to 12 hours.
6. Drain and discard marinade. Pat all slices of beef with paper towels.
7. Place beef slices in a single layer on the first tray, leaving space around each slice for proper drying. Fill trays with remaining beef slices.
8. Stack trays on base with the top tray last.
9. Set the dehydrator to 160°F (70°C) for 4 to 8 hours. Start checking beef for doneness at 4 hours and then every 30 minutes. Jerky is dry when you can bend it and the top cracks, but the slice does not break.
10. Heat oven to 275°F (135°C).
11. Line a large cookie sheet with aluminum foil. Place jerky in a single layer, leaving a small space around each slice.
12. Bake for 10 to 12 minutes. Cool completely on a wire rack. Pat dry with paper towels before storing in an airtight container.

Makes: About 1 pound

Warning

This content is compiled from multiple sources and is provided for reference purposes only. It may not be complete or fully applicable to all situations. If you are unable to resolve your issue, please contact the product manufacturer or an authorized service provider for official support.

