

Battery

If the generator is equipped with electric start system, you need to install the battery properly, which may not be provided. The regular battery should be Pb-acid AGM battery with following specifications: Voltage 12V. lead-acid battery with 17AH, or 12V Li-battery with 1.6AH respectively.

First, install battery onto the frame securely with provided accessories. Connect the wires to the electrical motor positive electrode and battery positive electrode, electrical motor negative and battery negative electrode respectively.

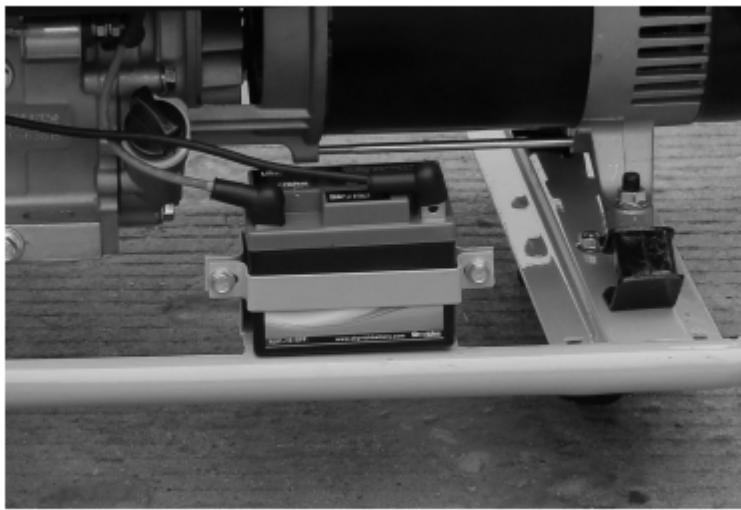

During connection, DO NOT touch battery's positive electrode and negative electrode directly.

Caution: Connecting or touching the Battery's positive electrode and negative electrode directly may cause battery burning and cause damage to the equipment or even more serious accident!

Operation

Before Starting the Generator

CAUTION: PRIOR TO FIRST USING THE GENERATOR, THE ENGINE MUST BE FILLED WITH HIGH QUALITY SAE 10W-30 GRADE ENGINE OIL. TO DO SO, UNSCREW AND REMOVE THE ENGINE'S OIL DIPSTICK LOCATED AT THE BOTTOM OF THE ENGINE CRANKCASE. FILL THE ENGINE CRANKCASE UNTIL THE OIL LEVEL IS LEVEL WITH THE UPPER MARKED LINE ON THE DIPSTICK. THEN SCREW THE DIPSTICK BACK INTO THE OIL FILL HOLE.



1. Check that the engine power switch is in its "OFF" position.
2. Before the first use, remove the fuel tank cap and fill the fuel tank with unleaded gasoline. When fueling, be sure that the fuel strainer is in place. Replace the fuel tank cap. Thereafter, check the engine's fuel gauge for the amount of unleaded gasoline in the fuel tank. If necessary, refill the fuel tank with unleaded gasoline; the generator must be turned off and cooled down before refilling the fuel tank.

Warning: Use gasoline with a pump octane rating of 90 or higher. We recommend unleaded gasolining because it produces fewer engine and spark plug deposits and extends exhaust system life. Never use stale or contaminated gasoline or oil/gasoline mixture. Avoid getting dirt or water in the fuel tank.

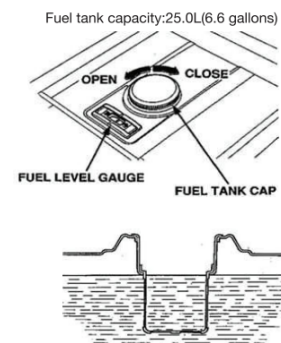

Starting

1. Turn the engine switch to the ON position.

The engine switch enables and disables the ignition system.

OFF: To stop the engine ON: To run the engine



2. The fuel valve is located under the fuel tank .
When the valve lever is in the ON position, fuel is allowed to flow from the fuel tank to the carburetor.
Be sure to return the fuel valve lever to the OFF position after stopping the engine.

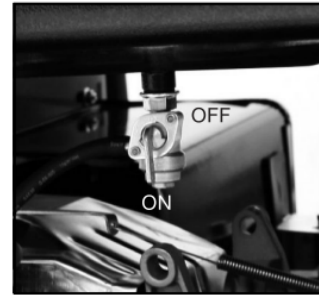

3. To start a cold engine, move the choke lever to the CLOSED position. To restart a warm engine, leave the choke lever in the OPEN position.

The choke lever opens and closes the choke valve in the carburetor.

The CLOSED position enriches the fuel mixture from starting a cold engine.

The OPEN position provides the correct fuel mixture for operation after starting, and for restarting a warm engine.



4. Operate the Recoil Starter:

Pull the starter grip lightly until you feel resistance, then pull briskly. Return the starter grip gently. Pulling the starter grip operates the recoil starter to crank the engine

Operate the Electric start:

Push and hold the engine switch on the "START" position for 3~5s and crank the engine.



5. If the choke has been moved to the CLOSED position to start the engine, gradually move it to the OPEN position as the engine warms up.

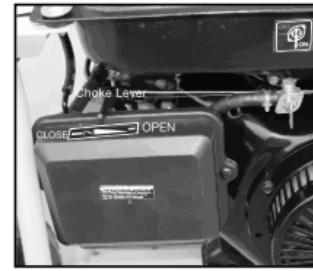

Stopping Engine

1. Turn the engine switch to the OFF position.



2. Turn the fuel valve lever to the OFF position.

When the engine is not in use, leave the fuel valve in the OFF position to prevent carburetor flooding and to reduce the possibility of fuel leakage.

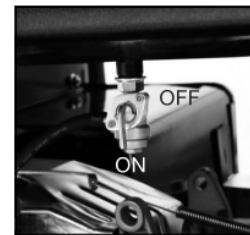

Powering 120/240 Volt AC Tools And Equipment:

1. Prior to powering tools and equipment, make sure the generator's rated voltage, and amperage capacity is adequate to supply all electrical loads that the unit will power. If powering exceeds the generator's capacity, it may be necessary to group one or more of the tools and/or equipment for connection to a separate generator.
2. Once the generator is running, simply connect the power cords of 120/240volt AC powered tools and equipment into the 120/240volt AC dual outlets.
3. Disconnect all electrical powered tools and equipment from the generator's 120/240volt AC dual outlets.
4. After the engine and generator have completely cooled, store generator in a safe, clean, dry location (if not already installed).

Powering 12 Volt DC tools and Equipment:

1. Prior to powering tools and equipment, make sure the generator's rated voltage, and amperage capacity (12V DC) is adequate to supply all electrical loads that the unit will

power. If powering exceeds the generator's capacity, it may be necessary to group one or more of the tools and/or equipment for connection to a separate generator.

2. Connect the power cord of a 12 VDC powered tool or equipment to the DC Terminals.

Inspection, Cleaning, and Maintenance

Spark Plug Maintenance

In order to service the spark plug, you will need a spark plug wrench (commercially available). Recommended spark plugs: TORCH F6RTC but we recommend our OEM sparkplug.

To ensure proper engine operation, the spark plug must be properly gapped and free of deposits.

1. Remove the spark plug cap.
2. Clean any dirt from around the spark plug base.
3. Use a spark plug wrench to remove the spark plug.

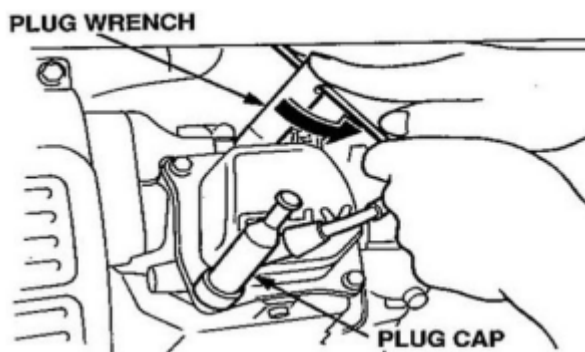

4. Visually inspect the spark plug. Discard it if the insulator is cracked or chipped. Clean the spark plug with a wire brush if it is to be reused.
5. Measure the plug gap with a feeler gauge. (Correct as necessary by carefully bending the side electrode.) The gap should be : 0.70-0.80 mm (0.028-0.031 in)

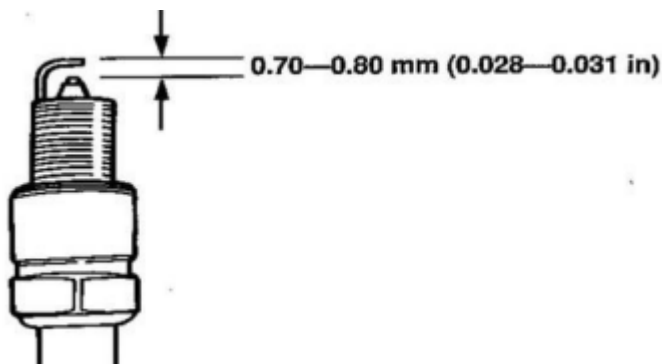

6. Check that the spark plug washer is in good condition
7. After the spark plug is seated, tighten with a spark plug in by hand to prevent cross-threading.

8. After the spark plug is seated, tighten with a spark plug wrench to compress the washer.

Fuel Sediment Cup Cleaning

The sediment cup prevents dirt or water which may be in the fuel tank from entering the carburetor. If the engine has not been run for a long time, the sediment cup should be cleaned.

1. Turn the fuel valve to the OFF position. Remove the sediment cup, and O-ring.
2. Clean the sediment cup, and O-ring, in nonflammable or high flash point solvent.
3. Reinstall O-ring, and sediment cup.
4. Turn the fuel valve ON and check for leaks.

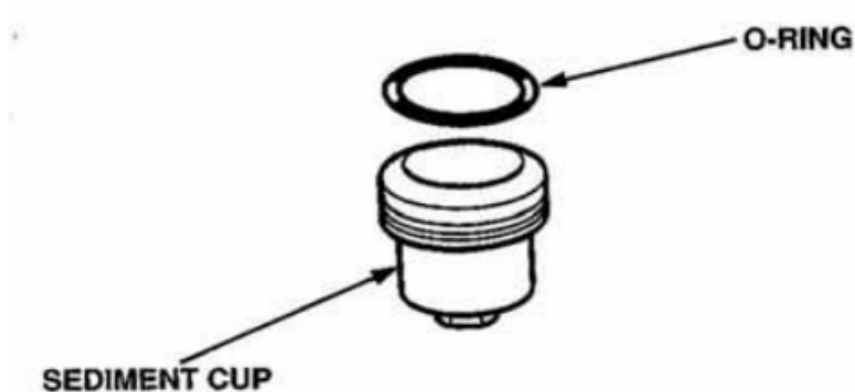
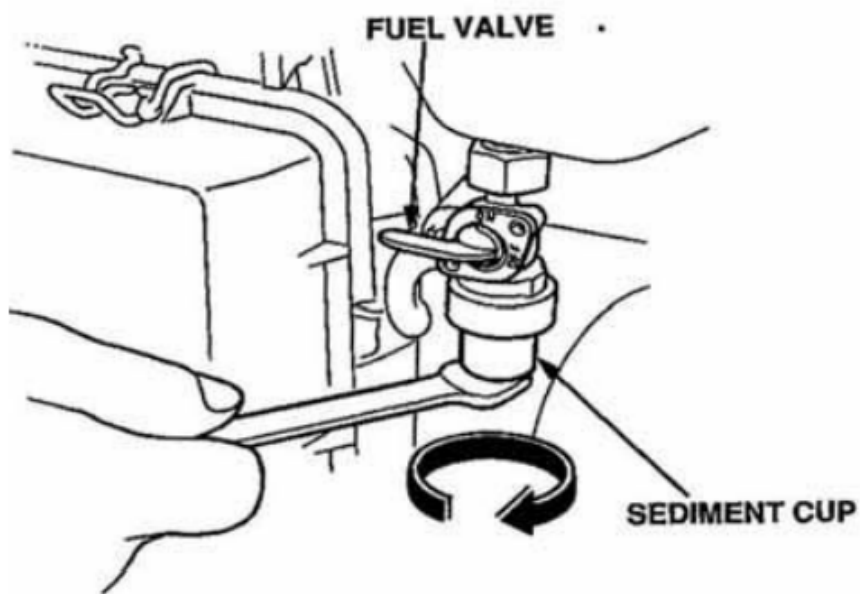

Maintenance Guide

Periodic maintenance and adjustment is necessary to keep the generator in good operating condition.

WARNING! Exhaust gas contains poisonous carbon monoxide. Shut off the engine before performing any maintenance. If the engine must be run, make sure the areas is well ventilated.

- Before each use, inspect the generator. Check for:
 - Loose screws
 - Misaligned or binding moving parts
 - Cracked or broken parts
 - Damaged electrical wiring
 - Any other condition that may affect safe operation.
- If an engine problem occurs, have it checked by a qualified service technician before further use. Do not use damaged equipment.
- Before each use, make sure the engine's oil and gas levels are adequate. If necessary, fill the crankcase until the oil level is even with the oil hill hole and/or fill the fuel tank.
- Before each use, remove all debris with a soft brush, rag, or vacuum.
- Lubricate all moving parts using a premium quality, lightweight machine oil.
- Every **50** hours of use, drain the old engine oil and replace with a high a high quality SAE **10W-30** grade engine oil.
- Every 300 hours of use, have a qualified, certified technician perform thorough maintenance on the generator and engine.
- For long term storage, either drain fuel into suitable container or add a fuel preservative/ stabilizer (not included) to prevent fuel breakdown.

Air cleaner Maintenance

A dirty air cleaner will restrict air flow to the carburetor, lower generator output power and deteriorate the engine emission To prevent carburetor malfunction, service the air cleaner regularly. Service more frequently when operating the generator in extremely dusty areas.

1. Unsnap the air cleaner cover clips, remove the air cleaner cover, and remove the element.
2. Wash the element in a solution of household detergent and warm water, then rinse thoroughly, or wash in nonflammable or high flash point solvent. Allow the element to dry thoroughly.



3. Soak the element in clean engine oil and squeeze out the excess oil. The engine will smoke during initial start-up if too much oil is left in the element.
4. Reinstall the air cleaner element and the cover.

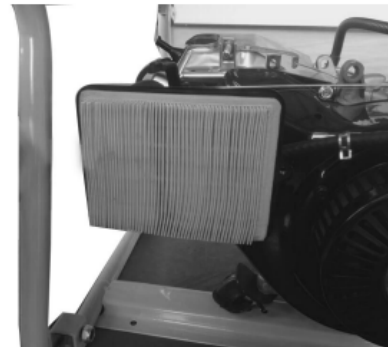

Transporting/Storage

When transporting the generator, turn the engine switch and the fuel valve OFF. Keep the generator level to prevent fuel spillage. Fuel vapor or spilled fuel may ignite.

Take care not to drop or strike the generator when transporting. Do not place heavy objects on the generator.

Before storing the unit for an extended period:

1. Be sure the storage area is free of excessive humidity and dust.
2. Service according to the table below:

STORAGE TIME	RECOMMENDED SERVICE PROCEDURE TO PREVENT HARD STARTING
Less than 1 month	No preparation required
1 to 2 months	Fill with fresh gasoline and add gasoline conditioner*.
2 months to 1 year	Fill with fresh gasoline and add gasoline conditioner*. Drain the carburetor float bowl. Drain the fuel sediment cup.
1 year or more	Fill with fresh gasoline and add gasoline conditioner*. Drain the carburetor float bowl. Drain the fuel sediment cup. Remove the spark plug. Put a tablespoon of engine oil into the cylinder. Turn the engine slowly with the pull rope to distribute the oil. Reinstall the spark plug. Change the engine oil. After removal from storage, drain the stored gasoline into a suitable container, and fill with fresh gasoline before starting.

1. Drain the carburetor by loosening the drain screw. Drain the gasoline into a suitable

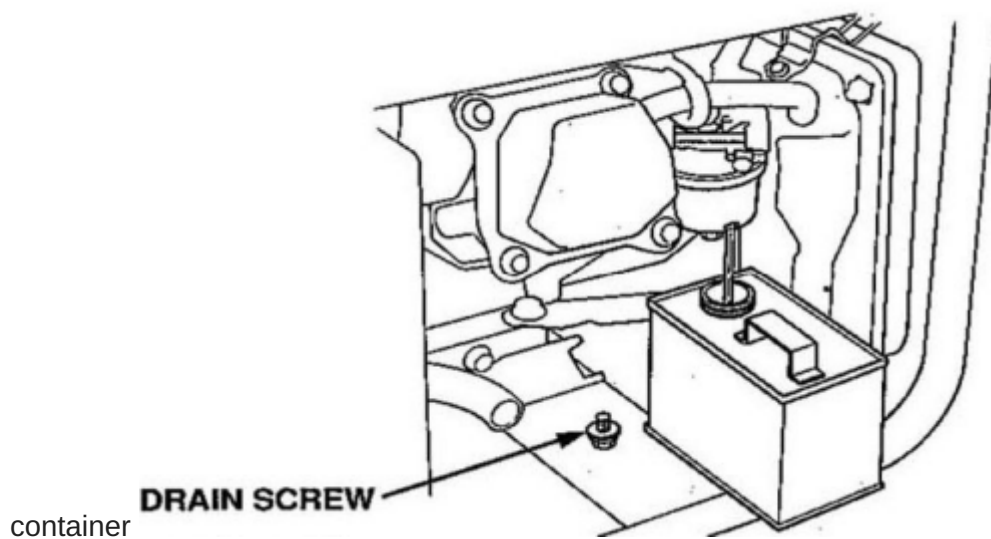

2. Change the engine oil

3. Remove the spark plug, and pour about a tablespoon of clean engine oil into the cylinder. Crank the engine several revolutions to distribute the oil, then reinstall the spark plug.
4. Slowly pull the starter grip until resistance is felt. At this point, the piston is coming up on its compression stroke and both the intake and exhaust valves are closed. Storing the engine in this position will help to protect it from internal corrosion



SPECIFICATIONS

AC electrical

	6500W	8000W	10000W
Current Output	22.9	27	31
Running Watts	5,500	6,500	7,500
Starting Watts	6,500	8,000	10,000
Outlet	Four 120V 20A NEMA 5-20 Receptacle One 120V 30A NEMA L5-30 Receptacle One 120/240V 30A NEMA L14-30 Receptacle		

DC electrical

Outlet	12V@8.3A
--------	----------

Gasoline engine

Type	4-cycle OHV air-cool ed recoil start
Displacement	420cc
Oil capacity	1.15
EPA approved	yes

Fuel

Type	Unleaded gasoline
Capacity	6.6 gallons
Running time	9 hours (approx.) on 1/2 load

Weight

	6500W	8000W	10000W
Approximate weight	154lbs	181lbs	188lbs

Warning

This content is compiled from multiple sources and is provided for reference purposes only. It may not be complete or fully applicable to all situations. If you are unable to resolve your issue, please contact the product manufacturer or an authorized service provider for official support.