

USER MANUAL COMPACT SIZE FOOD WASTE DISPOSER



Sound Seal® Technology

1. Quiet Collar® Sink Baffle
2. Anti-Vibration Mount®
3. Anti-Vibration Tailpipe Mount™

Multi Grind® Technology

4. GrindShear Ring®
5. Quick Lock® Sink Mount
6. Stainless Steel Grind Components
7. 3/4 HP Heavy Duty Dura-Drive® Motor

Dimensions

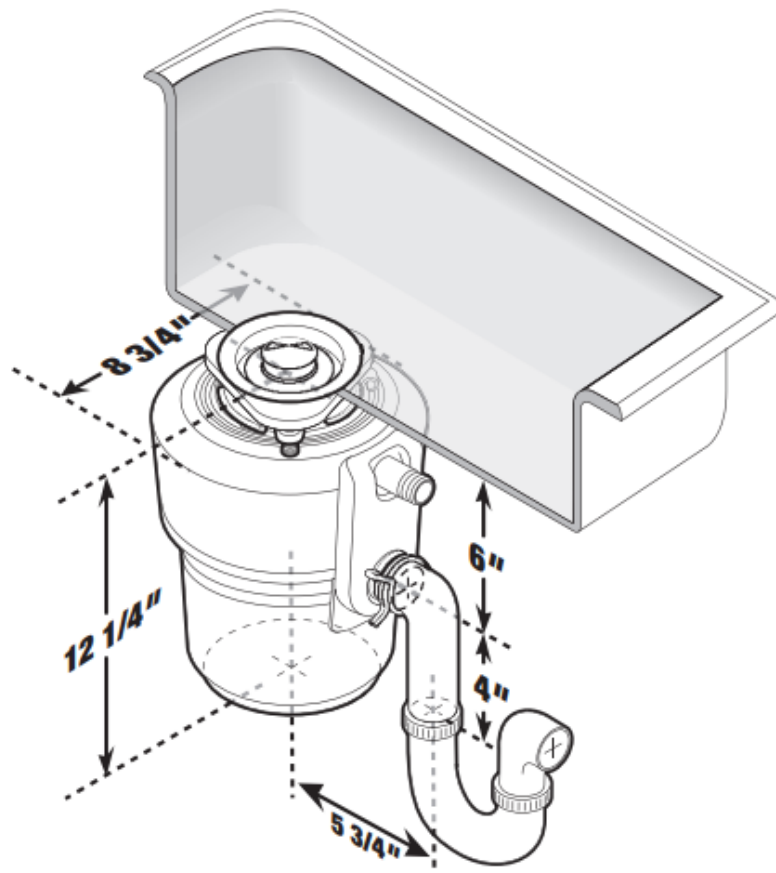

Includes

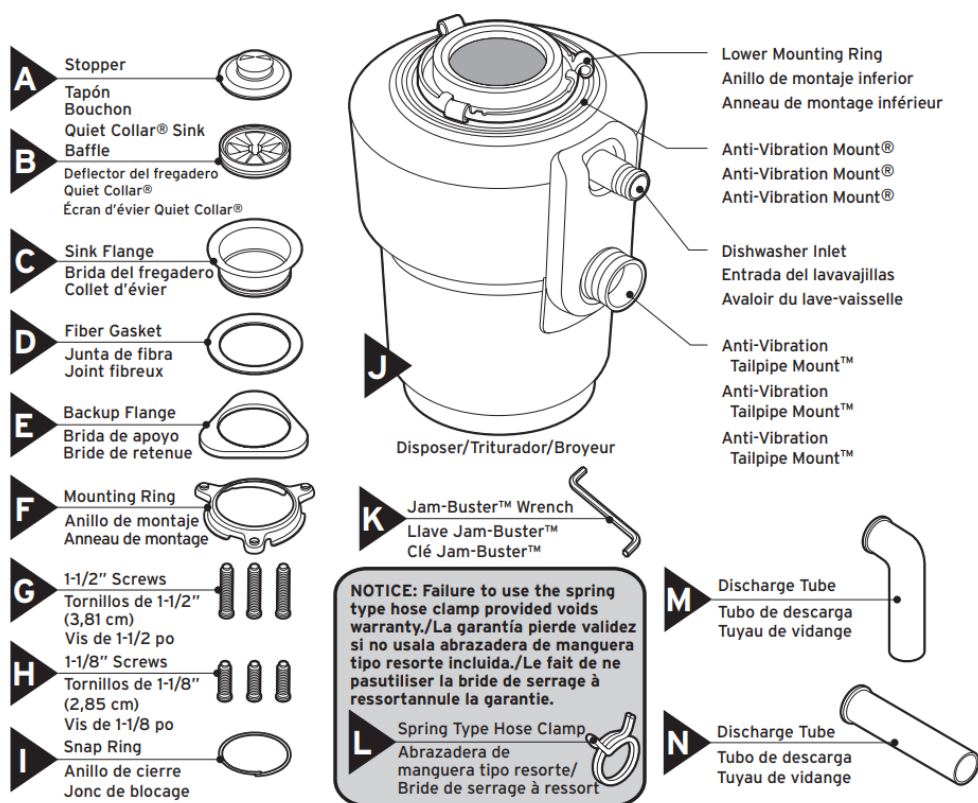

REMOVAL OF OLD DISPOSER

1. If you are replacing an existing disposer, continue to Step 2. If there is no existing disposer, disconnect sink drain and skip to Step 9.
2. Disconnect drain trap from waste discharge tube. Disconnect dishwasher if connected to the disposer

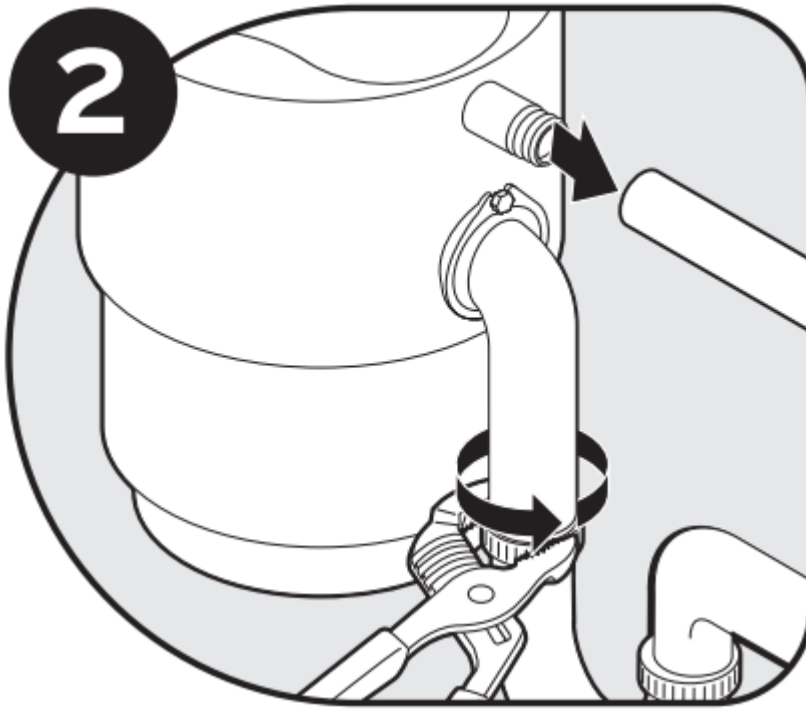

3. Support disposer, insert end of Jam-Buster™ Wrench (K) into right side of mounting lug, and turn. Disposer will fall free.

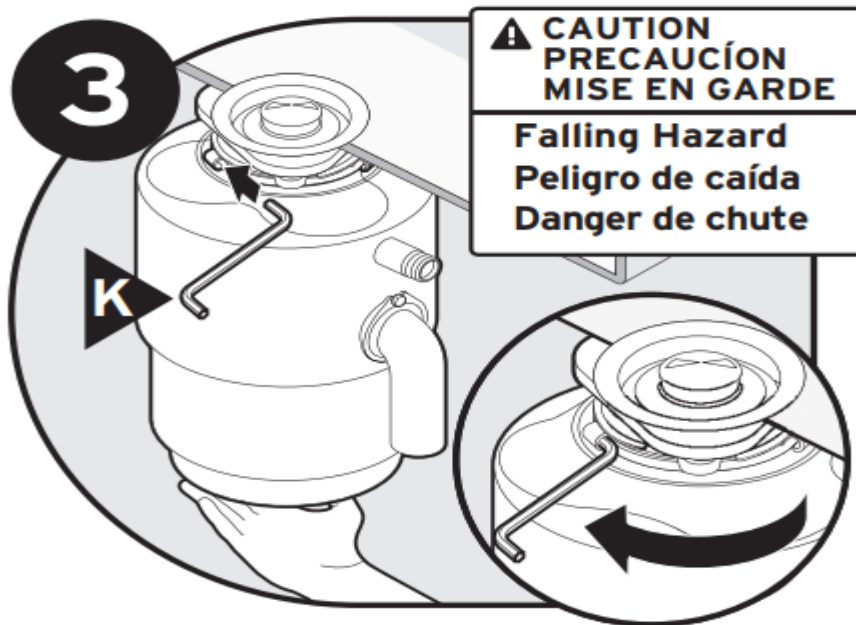

4. Flip disposer over and remove electrical cover plate. Save cable connector if applicable.



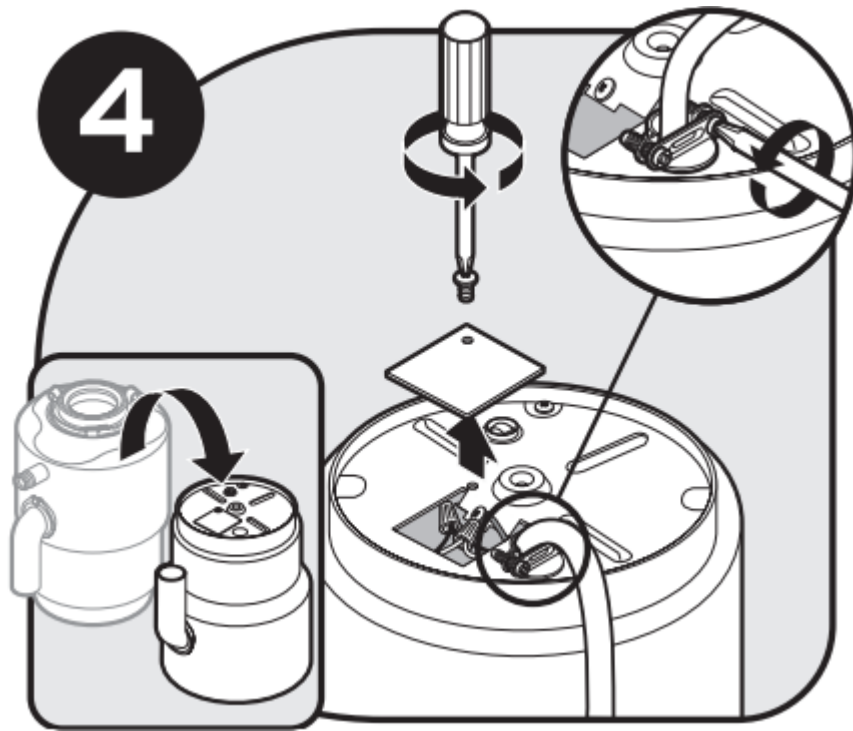

5. Disconnect the disposer wires from the electrical supply

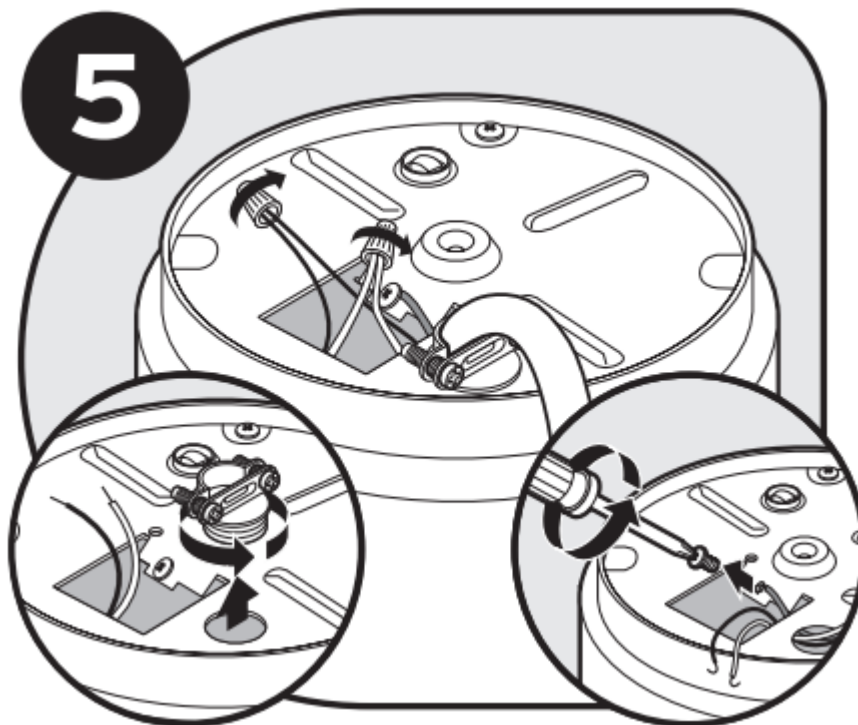

If the new disposer mounting is the same as the old one, you can go to Step 14.

Note: For sinks thicker than $\frac{3}{8}$ ", you will need to replace existing $1\frac{1}{2}$ " screws with $1\frac{1}{8}$ " screws (H). See Step 13.

6. Loosen the 3 screws on the mounting assembly.

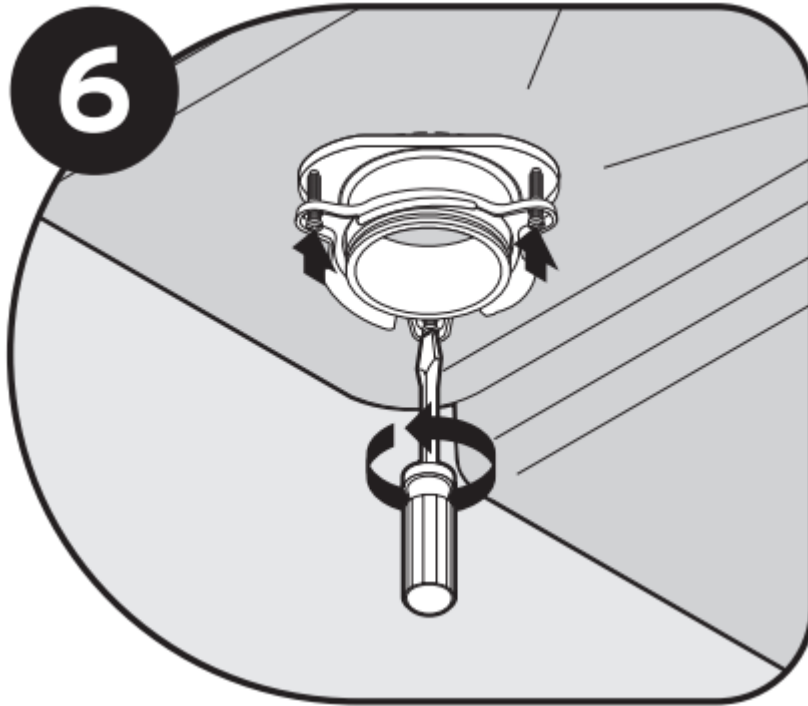

7. Using a screwdriver, remove the snap ring.

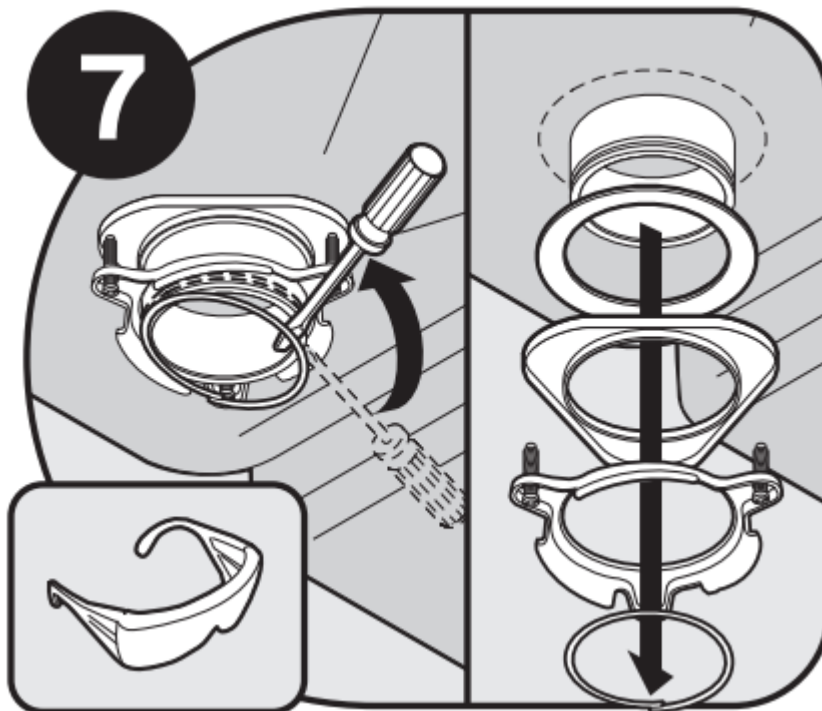

8. Remove flange from sink. Remove old plumber's putty from sink with putty knife.

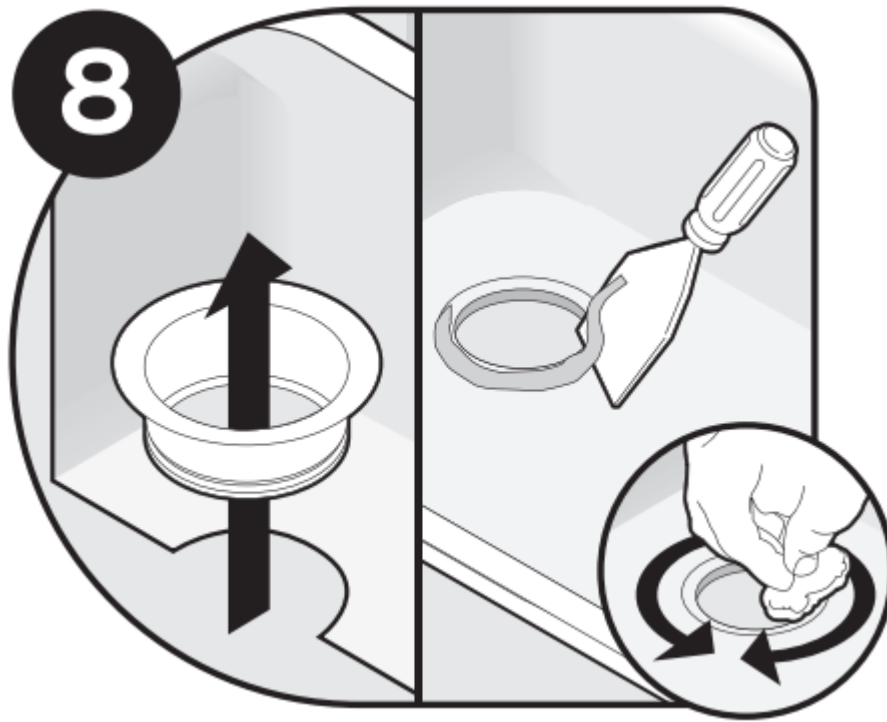

Installation Instructions

9. Evenly apply 1/2" thick rope of plumber's putty around flange (C).

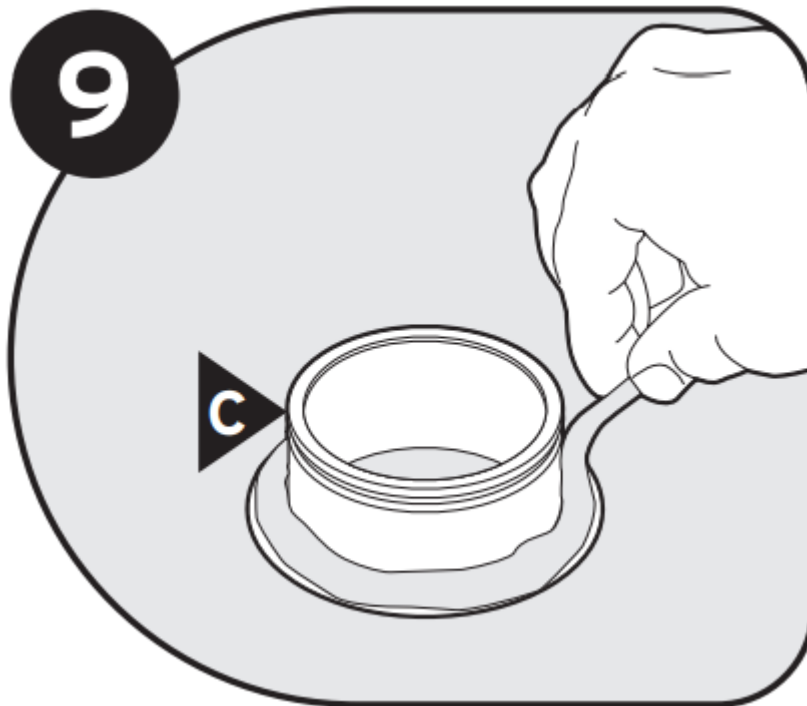

10. Press flange (C) firmly into sink drain. Remove excess putty

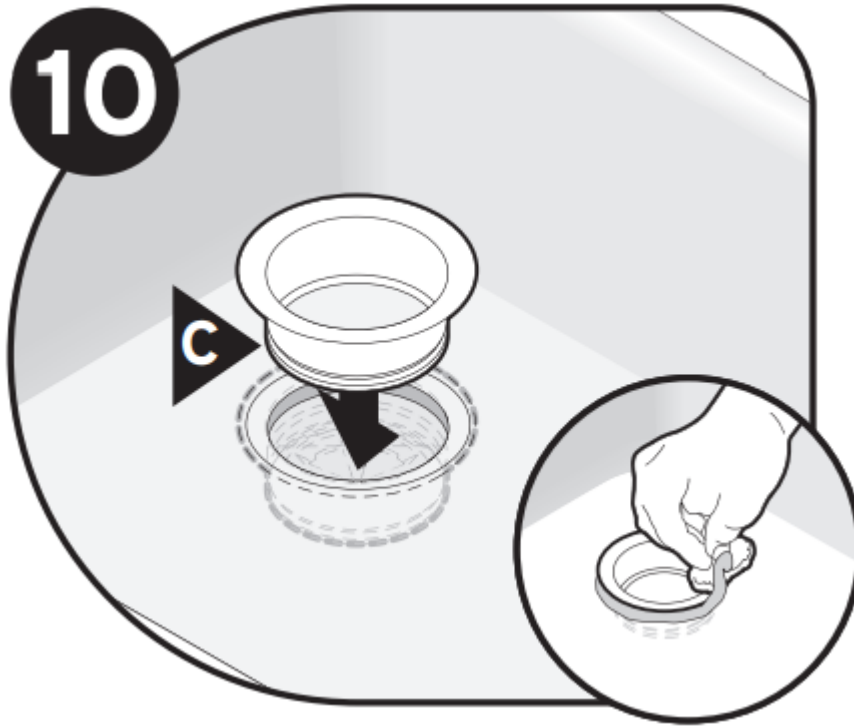

11. Insert fiber gasket (D), backup flange (E) and mounting ring (F). Hold flange (C) in place while inserting snap ring (I).

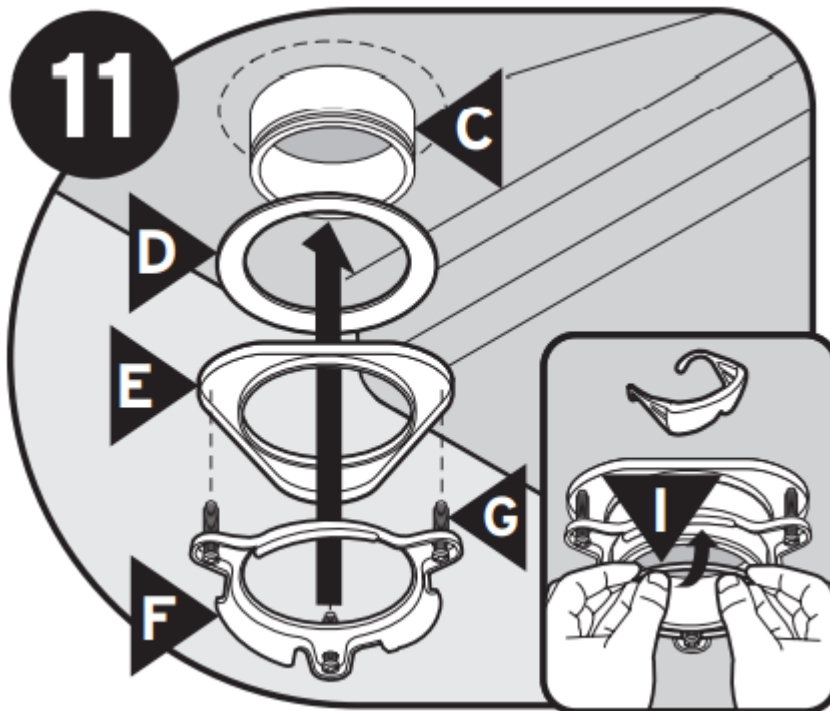

12. Place a weight such as the disposer on the sink flange to hold it in place. Use a towel to prevent scratching sink. Pull snap ring (I) open and press firmly until it snaps into place

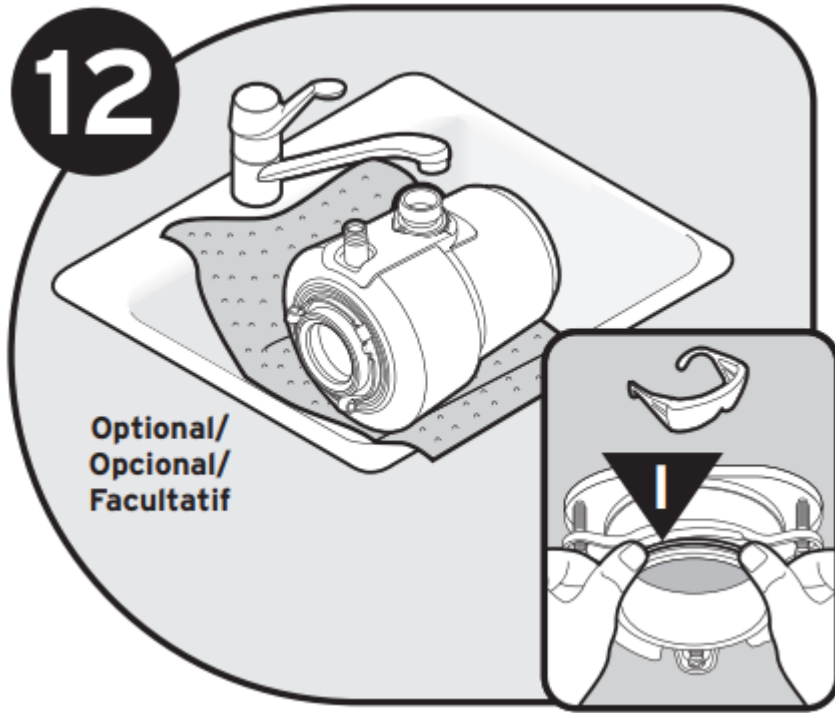

13. Tighten 1-1/2" screws (G) evenly and firmly against backup flange. Use shorter 1-1/8" screws (H) if sink is more than 3/8" thick.

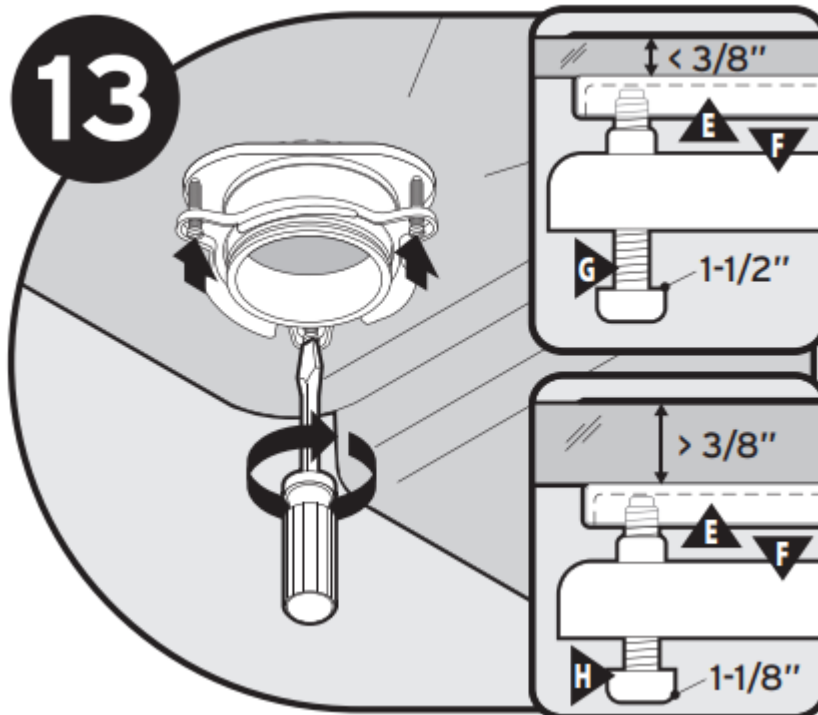

14. * NOTICE: DISHWASHER CONNECTION ONLY. If you do not need to attach the dishwasher, go to Step 16. Turn disposer (J) onto side and insert screwdriver into dishwasher inlet.

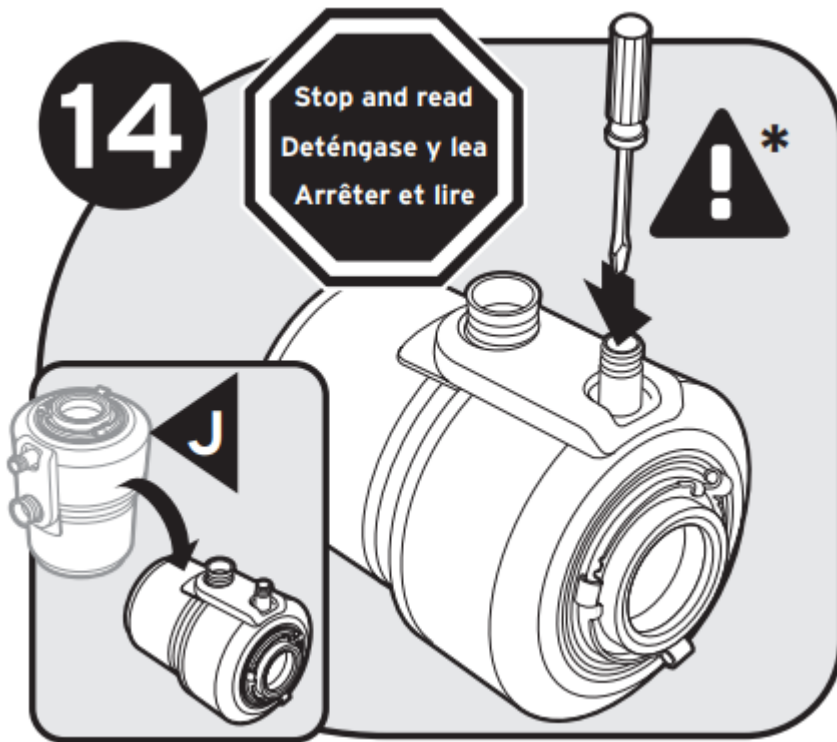

15. * NOTICE: DISHWASHER CONNECTION ONLY. Knock out drain plug and remove plug from inside of disposer

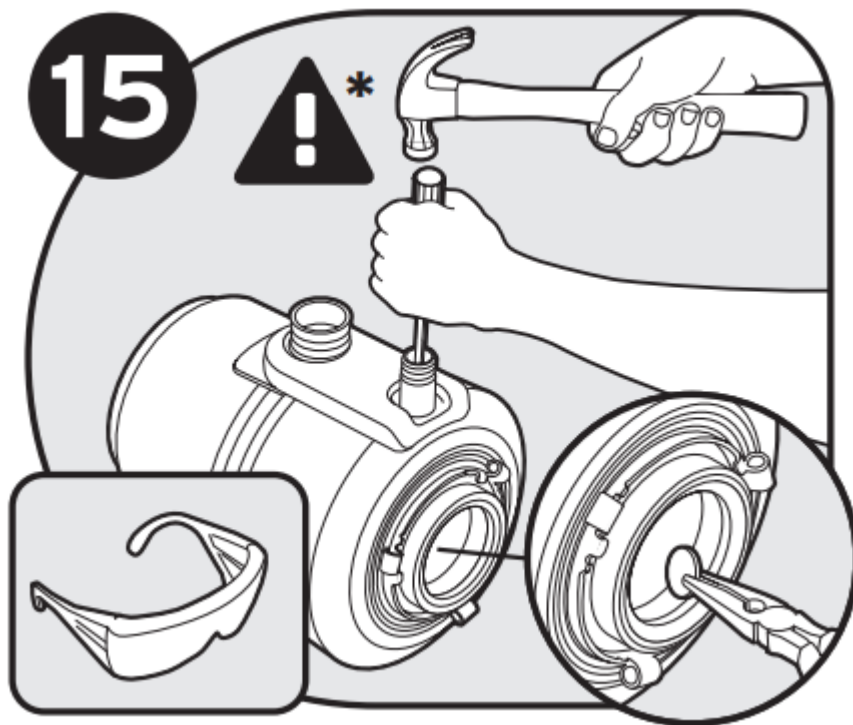

16. Turn disposer over and remove electrical cover plate. Pull out wires. DO NOT REMOVE CARDBOARD SHIELD.

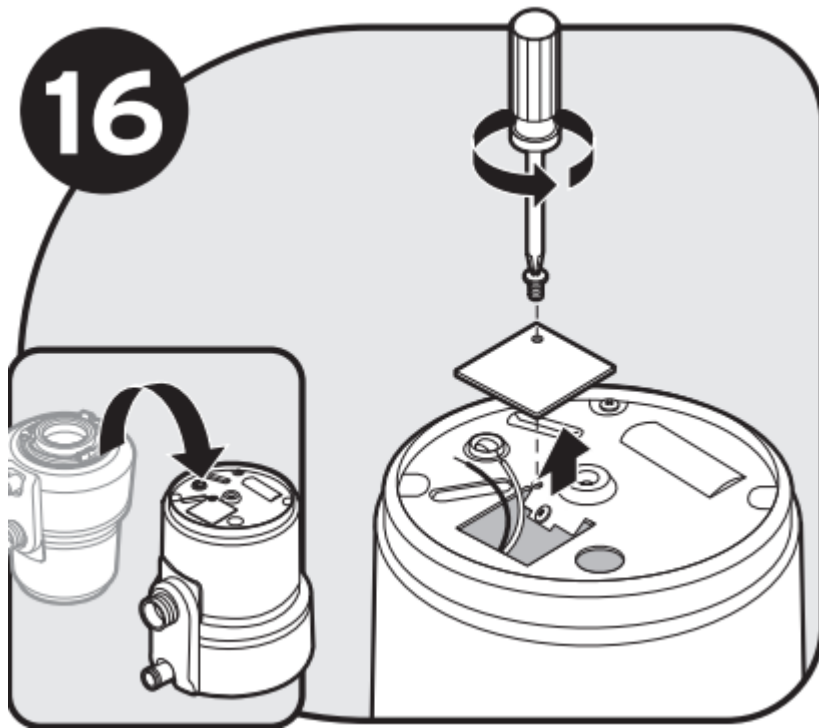

17. Insert cable connector (not included) and run electrical cable through access hole on bottom of disposer. Tighten cable connector.

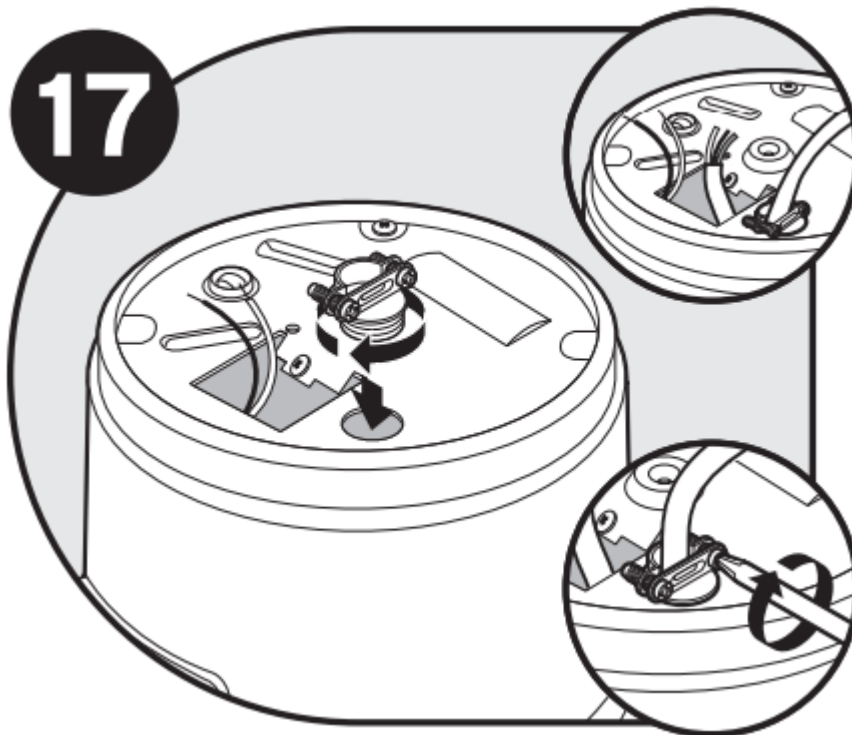

18. This disposer requires a switch (15 amp minimum rating) with a marked "Off" position (wired to disconnect all ungrounded supply conductors) installed within sight of the disposer sink opening, except if using an air switch or batch feed accessory, or batch feed disposer.

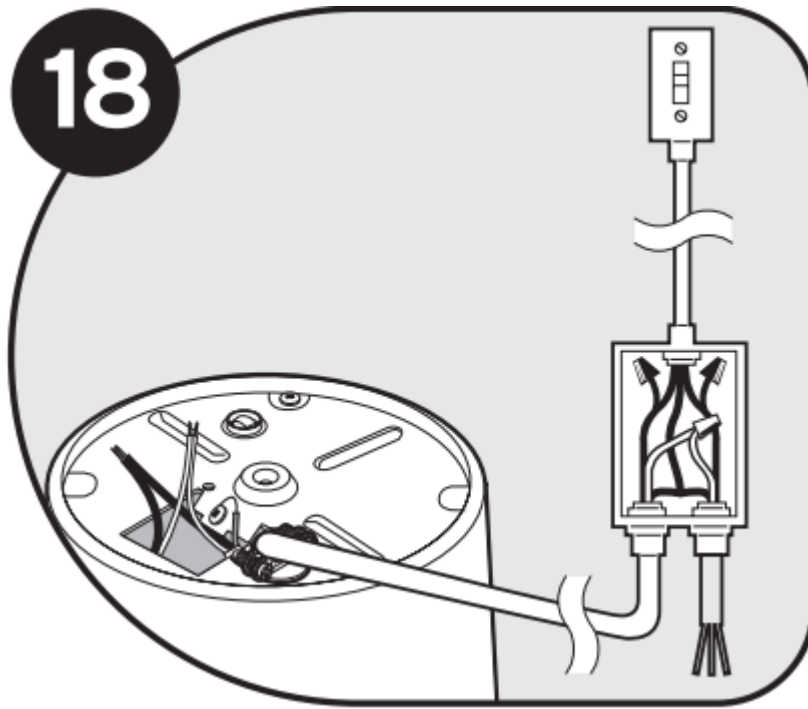

19. * **WARNING!** Improper grounding can result in electric shock hazard. Connect white wire from disposer to neutral (white) wire from power source and black wire from disposer to hot (black, red) wire from power source with wire nuts (not included); ground wire to green grounding screw. Unit must be grounded for safe and proper installation.

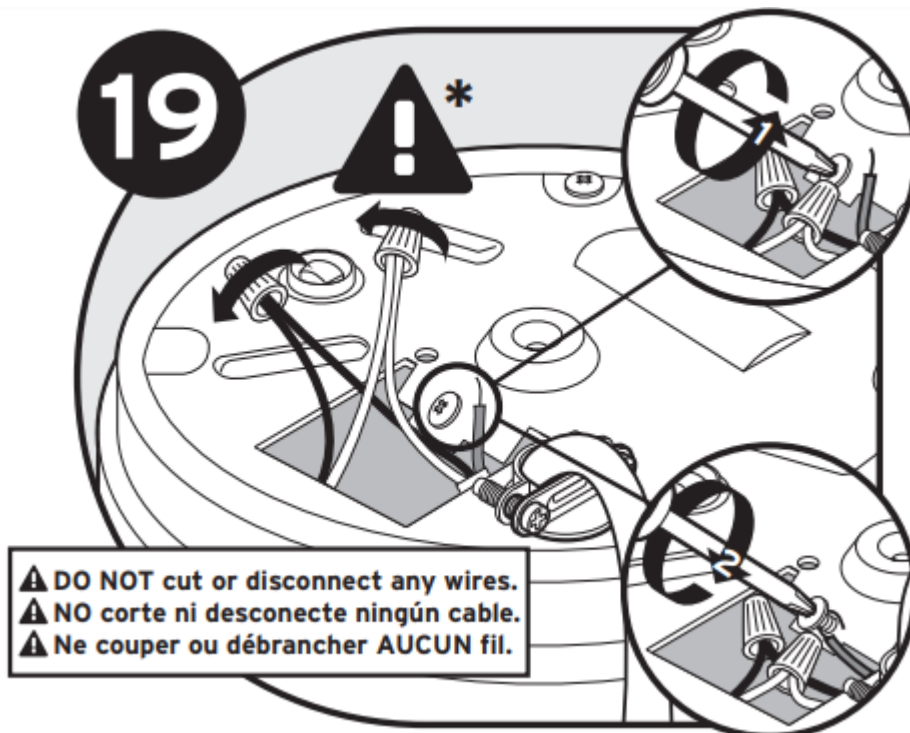

20. Push wires into disposer (do not displace cardboard shield) and replace electrical cover plate.

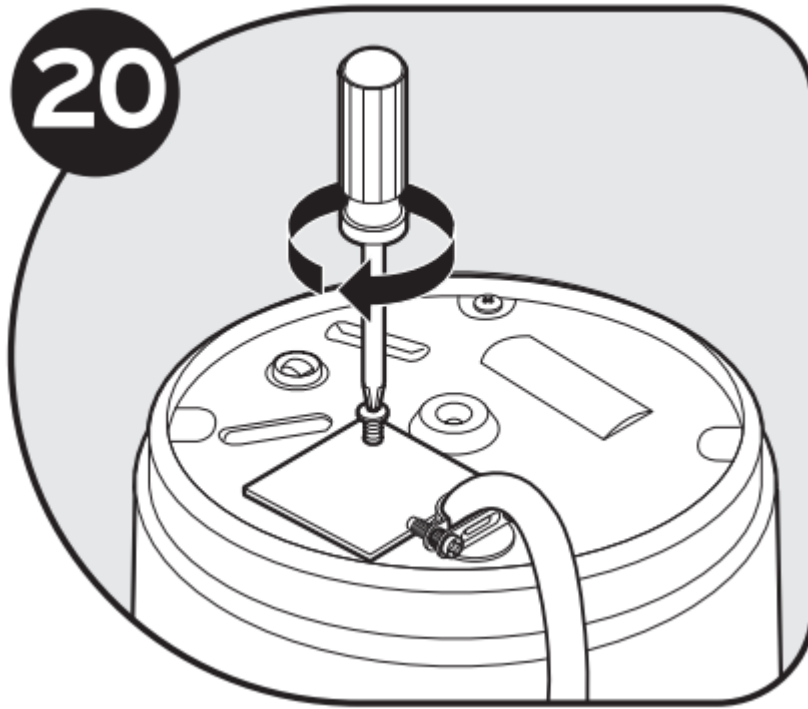

21. Place tube (M or N) into Anti-Vibration Tailpipe Mount™. Use provided tubes for best results. Secure with spring type hose clamp (L). * Important: Failure to use the spring type hose clamp provided voids warranty.

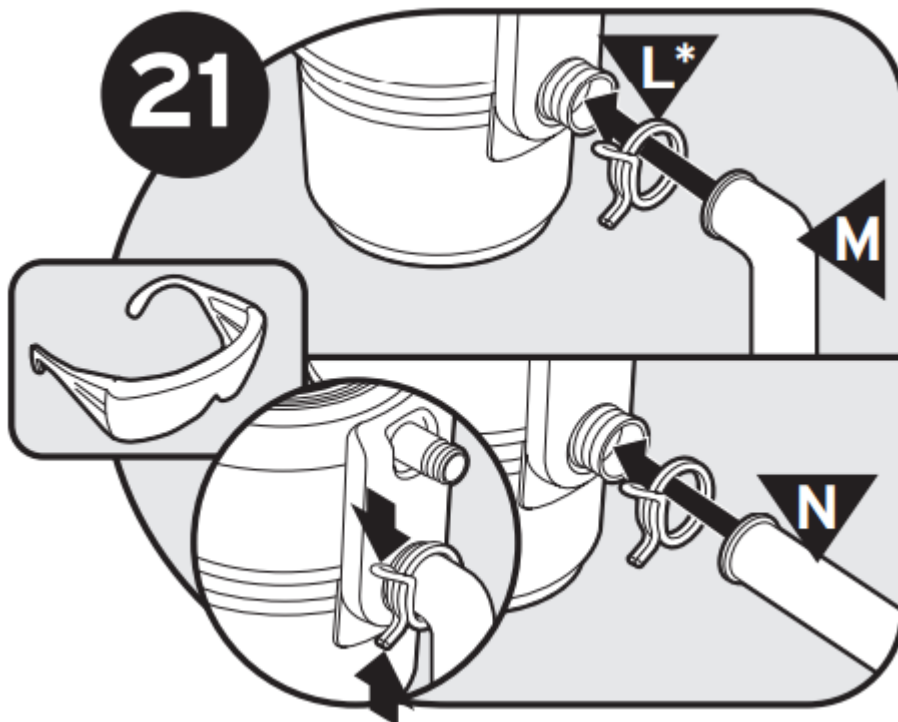

22. Detach removable portion of spec label and place on a visible location after installation.

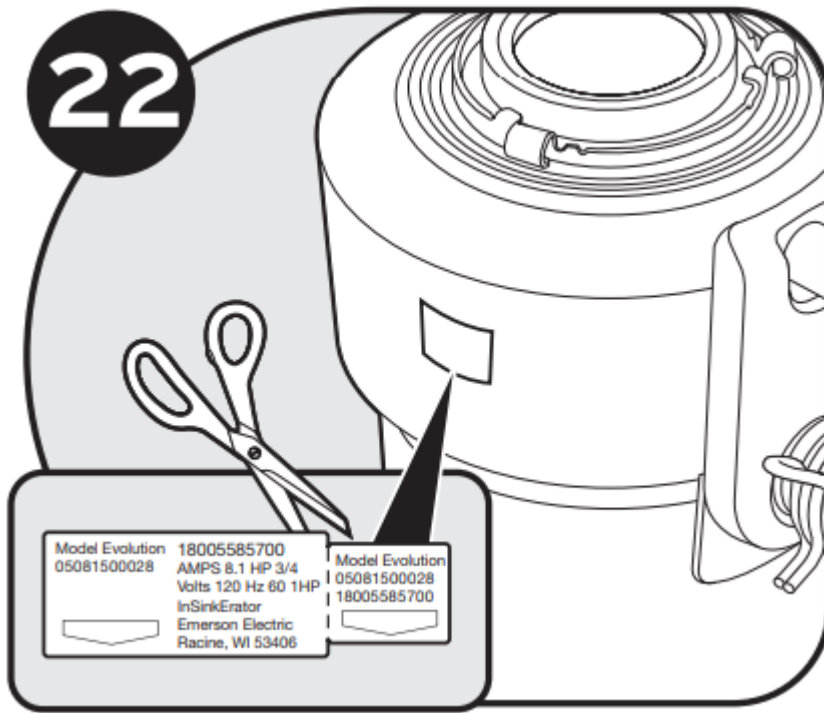

23. * CAUTION: Do not position your head or body under disposer; unit could fall during removal or installation. Hang disposer by aligning 3 mounting tabs with slide-up ramps on mounting ring

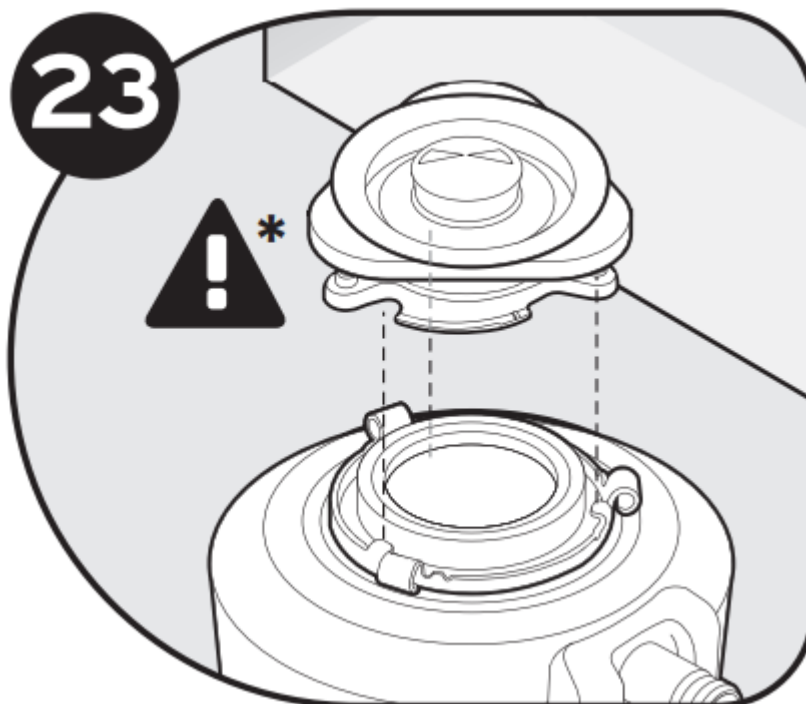

24. Turn mounting ring until all 3 mounting tabs lock over the ridges on the slide-up ramps.

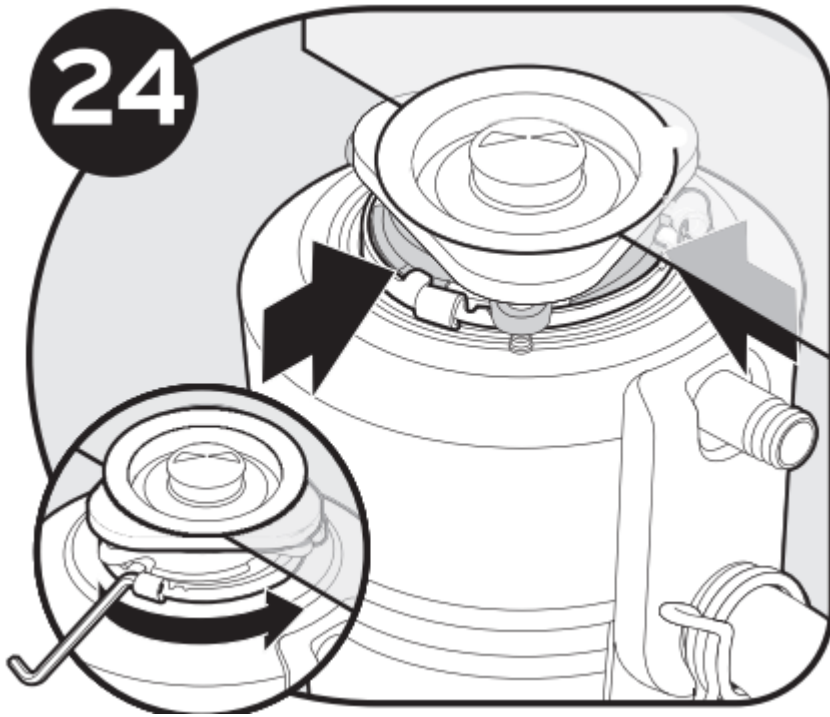

25. You may need to trim tube for proper fit. Reconnect plumbing (and dishwasher connection if used). Make sure Anti-Vibration Tailpipe Mount™ is straight.

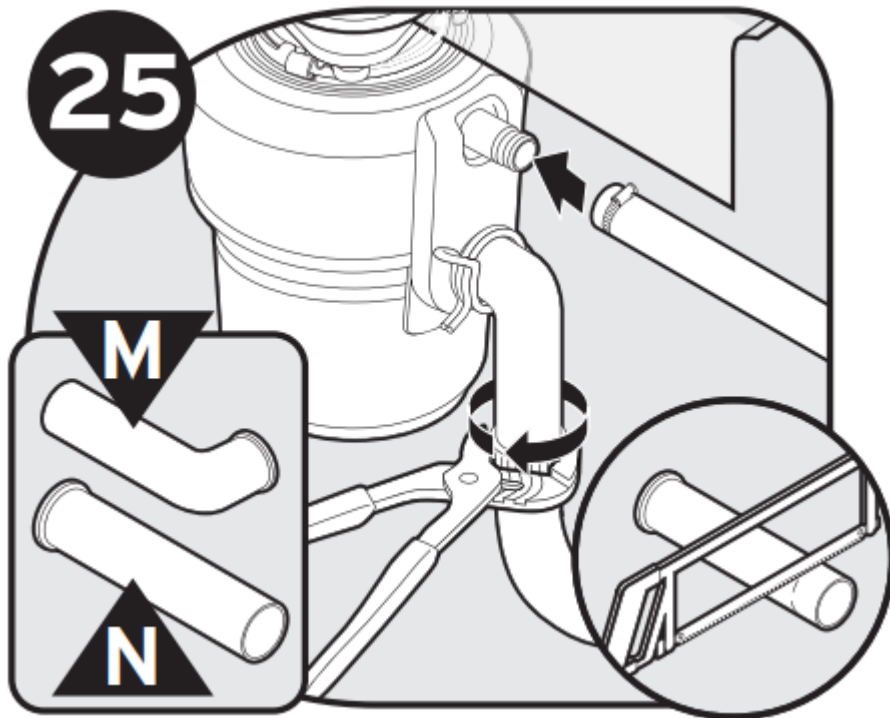

26. Insert Quiet Collar® Sink Baffle into sink opening. Fill sink with water, then test for leaks.





OPERATING INSTRUCTIONS

1. Remove stopper from sink opening and run cold water.
2. Turn on wall switch to start disposer.
3. Slowly insert food waste into disposer. **WARNING!** Position stopper to minimize possible ejection of material while grinding.
4. After grinding is complete, turn disposer off and run water for a few seconds to flush drain line.

DO...

- First turn on cold water and then turn on the disposer. Continue running cold water for several seconds after grinding is completed to flush the drain line.
- Grind hard materials such as small bones, fruit pits, and ice. A scouring action is created by the particles inside the grind chamber.
- Grind peelings from citrus fruits to freshen up drain smells.
- Use a disposer cleaner, degreaser, or deodorizer as necessary to relieve objectionable odors caused by grease build-up.

DON'T...

- DON'T POUR GREASE OR FAT DOWN YOUR DISPOSER OR ANY DRAIN. IT CAN BUILD UP IN PIPES AND CAUSE DRAIN BLOCKAGES. PUT GREASE IN A JAR OR CAN AND DISPOSE IN THE TRASH.



- Don't use hot water when grinding food waste. It is OK to drain hot water into the disposer between grinding periods.
- Don't fill disposer with a lot of vegetable peels all at once. Instead, turn the water and disposer on first and then feed the peels in gradually.
- Don't grind large amounts of egg shells or fibrous materials like corn husks, artichokes, etc., to avoid possible drain blockage.
- Don't turn off disposer until grinding is completed and only sound of motor and water is heard.

USER MAINTENANCE INSTRUCTIONS

CLEANING DISPOSER

Over time, food particles may accumulate in the grind chamber and baffle. An odor from the disposer is usually a sign of food buildup. To clean disposer:

1. Place stopper in sink opening and fill sink halfway with warm water.
2. Mix 1/4 cup baking soda with water. Turn disposer on and remove stopper from sink at same time to wash away loose particles.
3. Remove Quiet Collar® Sink Baffle and clean by hand or in dishwasher. Do not operate disposer without Quiet Collar® Sink Baffle in place.

RELEASING DISPOSER JAM

If motor stops while disposer is operating, disposer may be jammed. To release jam:

1. Turn off disposer and water.
2. Insert one end of self-service Jam-Buster™ Wrench into center hole on bottom of disposer (see Figure A). Work Jam-Buster™ Wrench back and forth until it turns one full

revolution. Remove Jam-Buster™ Wrench.

Figure A

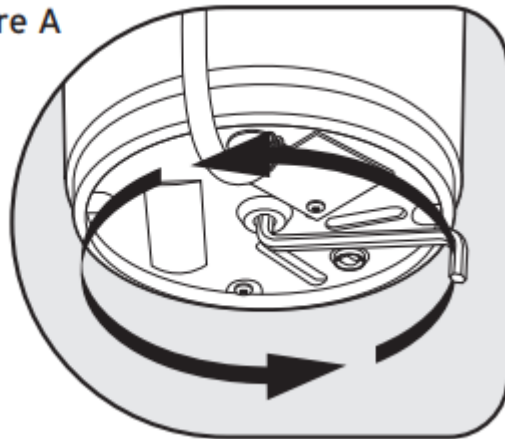

3. Reach into disposer with tongs and remove object(s). Allow disposer motor to cool for 3 - 5 minutes, then lightly push red reset button on disposer bottom (see Figure B). (If motor remains inoperative, check service panel for tripped circuit breakers or blown fuses.)

Figure B

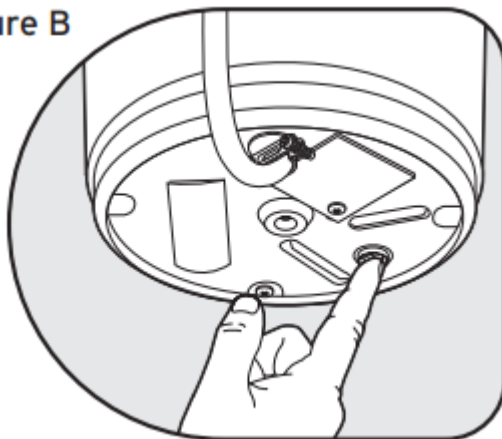

IMPORTANT SAFETY INSTRUCTIONS

For all grounded, cord-connected disposers:

This disposer must be grounded to reduce the risk of electric shock in the event of a malfunction or breakdown. Grounding provides a path of least resistance for electric current. If your disposer did not include a factory installed power cord, use a cord having an equipment-grounding conductor and a grounding plug. (InSinkErator power cord accessory CRD-00 recommended.) The plug must be plugged into an outlet that is properly installed and grounded in accordance with all local codes and ordinances.

For permanently connected disposers:

This disposer must be connected to a grounded, metal, permanent wiring system; or an equipment-grounding conductor must be run with the circuit conductors and connected to the equipment-grounding terminal or lead on the disposer.

WARNING: When using electric appliances, basic precautions are always to be followed, including:

- Read all instructions before using the appliance.
- To reduce the risk of injury, close supervision is required when an appliance is used near children.
- Do not put fingers or hands into a waste disposer.
- Turn the power switch to the off position before attempting to clear a jam, removing an object from the disposer or pressing reset button.
- When attempting to loosen a jam in a waste disposer, use the self-service wrenchette.
- When attempting to remove objects from a waste disposer, use long-handled tongs or pliers.
- Do not put the following into a disposer: clam or oyster shells, caustic drain cleaners or similar products, glass, china, or plastic, metal (such as bottle caps, steel shot, tin cans, or utensils), hot grease or other hot liquids.
- When not operating a disposer, leave the stopper in place to reduce the risk of objects falling into the disposer.
- This product is designed to dispose of normal household food waste; inserting materials other than food waste into disposer could cause personal injury and/or property damage.
- To reduce the risk of injury and/or property damage, do not use the sink containing the disposer for purposes other than food preparation (such as baby bathing or washing hair).
- Do not dispose of the following in the disposer: paints, solvents, household cleaners and chemicals, automotive fluids, plastic wrap.
- FIRE HAZARD: Do not store flammable items such as rags, paper or aerosol cans near disposer. Do not store or use gasoline or other flammable vapors and liquids in vicinity of disposer.
- LEAK HAZARD: Regularly inspect disposer and plumbing fittings for leaks, which can cause property damage and could result in personal injury

Warning

This content is compiled from multiple sources and is provided for reference purposes only. It may not be complete or fully applicable to all situations. If you are unable to resolve your issue, please contact the product manufacturer or an authorized service provider for official support.

