

## Control panel

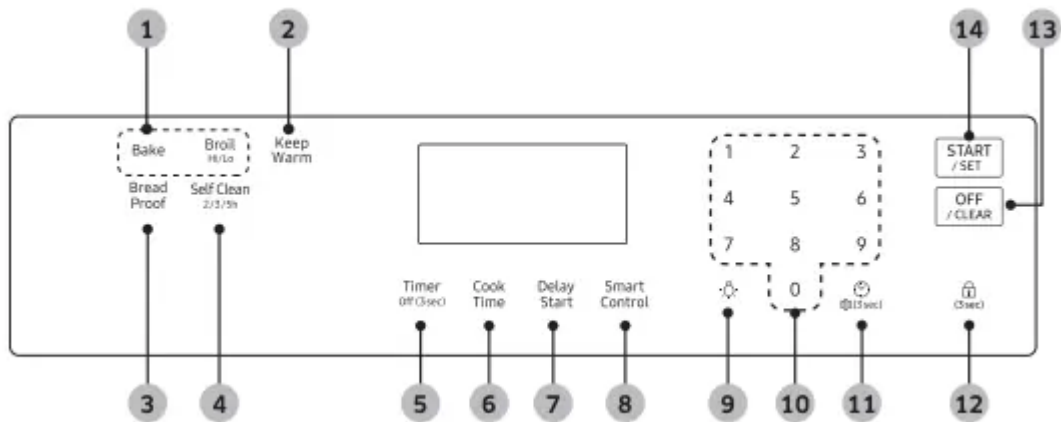

- 01 Oven modes: Activates each oven modes (Bake or Broil).
- 02 Keep Warm: Keep cooked food warm at 175 °F (80 °C).
- 03 Bread Proof: Activates the Bread Proof function.
- 04 Self Clean: Burn off food residues in the oven at very high temperatures.
- 05 Timer Off (3 sec): Activates or deactivates the timer.
- 06 Cook Time: Set the cooking time.
- 07 Delay Start: Set the oven to start at a certain time.
- 08 Smart Control: Activates the Easy connection.
- 09 Oven Light: Turn on/Turn off the oven light.
- 10 Numbers: Use to set the times, temperatures, or presets.
- 11 Clock: Set the clock time.
- 12 Lock: Press and hold for 3 seconds to lock the control panel and the door to prevent accidents.
- 13 OFF/CLEAR: Cancel the current operation but not the timer.
- 14 START/SET: Start a function or set the time.

## Before you start

You should know about the following features and components before you use your range for the first time.

## Clock

You must set the clock correctly to ensure the automatic features work properly.

### To set the clock time

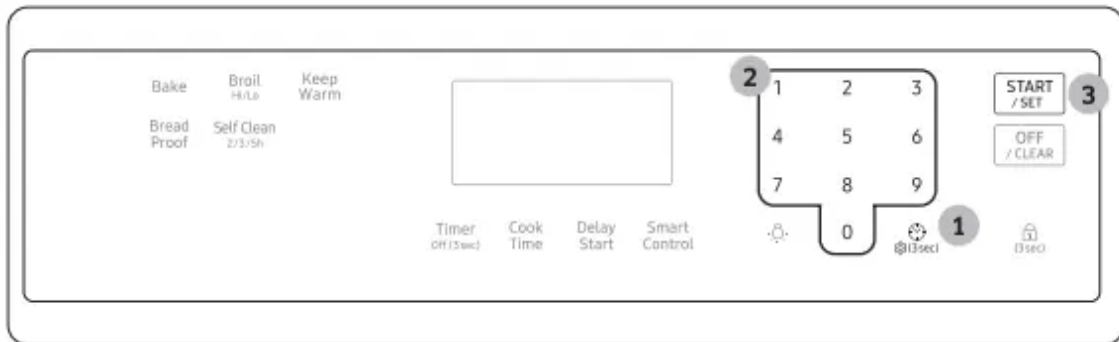

1. Press the .
2. Enter the current time using the number pad.
3. Press START/SET to confirm the settings.

 **NOTE** You can set/change the clock or the kitchen timer before you start a cooking mode or while most cooking modes are operating. However, you cannot set or change the time if a time based function is operating (Time Bake, for example) or the Sabbath option is enabled.

## Oven vent/cooling vent

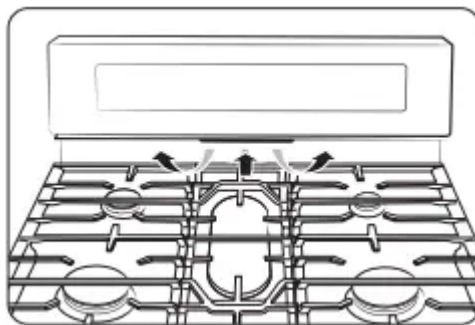

The oven vent is located under the oven Control panel. Proper air circulation prevents oven burner combustion problems and ensures good performance.

- Do not block the vent or its surroundings.
- Use caution when placing items near the vent. Hot steam can cause them to overheat or melt.

## Cooktop



**STEP 1** Put all ingredients into a cooking container (pan, pot, etc).



**STEP 2** Place the container on a surface burner.

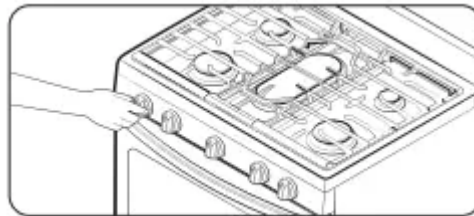

**STEP 3** Ignite the surface burner.

## Gas burners

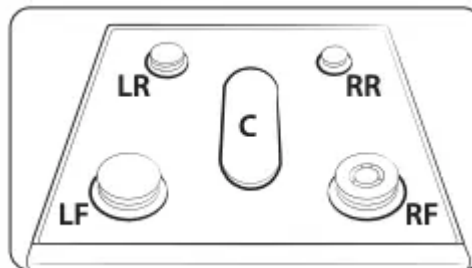

Each burner has a corresponding knob that lets you to set the flame level from LO to HI. In addition, each burner knob has a Lite setting. Turning a knob to Lite ignites the corresponding burner. The burner indicators are located above each knob and show which burner the knob controls. Each burner is designed for specific cooking purposes. See the table below.

### Position --- Purpose --- Food type ----Characteristics

**Right Front (RF) 18,000 BTU** -- Power heating -- Boiling food -- Maximum output

**Right Rear (RR) 5,000 BTU** -- Low simmering -- Chocolate, casseroles, sauces -- Delicate food that requires low heat for a long time

**Center (C) 10,000 BTU** -- General heating/ Griddling-- General food/ Pancakes, fried eggs -- General-purpose cooking

**Left Front (LF) 12,000 BTU** -- Quick heating -- General -- General-purpose cooking

**Left Rear (LR) 9,500 BTU** -- General heating/ Low simmering -- General food, casseroles --- General-purpose cooking

## Ignition

 **CAUTION**

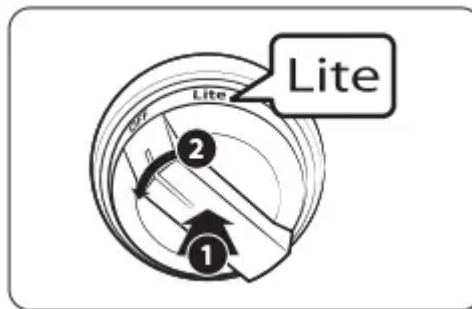

Make sure all surface burners are properly installed. To light a burner:

1. Push in the control knob, and then turn it to the Lite position. You will hear a “clicking” sound indicating the electronic ignition system is working properly.
2. After the surface burner lights, turn the control knob to shift it out of the Lite position and turn off the electronic ignition system.
3. Turn the control knob to adjust the flame level

## Manual ignition

If there is a power failure, you can ignite the burner manually. Use caution when doing this.

1. Hold a long gas grill lighter to the surface burner you want to light.
2. Push in the control knob for that burner, and then turn it to the Lite position. Turn on the grill lighter to ignite the burner.
3. After the burner is lit, turn the control knob to adjust the flame level.

## Flame level

The flames on the burners should always stay under the cookware, and should not extend beyond the cookware bottom at any time

 **WARNING**

- Flames larger than the cookware bottom may result in a fire or physical injury.
- When you set a burner to simmer, do not turn the burner knob quickly. Watch the flame to make sure it stays on.

- After turning on a surface burner, make sure that the burner has ignited. Adjust the level of the flame by turning the burner knob.
- Always turn off the surface burner controls before removing cookware. All surface burner controls should be turned OFF when you are not cooking.
- Always turn the burners off before you go to sleep or go out.
- If you smell gas, turn off the gas to the range and call a qualified service technician. NEVER use an open flame to locate a leak.

## **Cookware**

### **Requirements**

- Flat bottom and straight sides.
- Tight-fitting lid.
- Well-balanced with the handle weighing less than the main portion of the pot or pan.

### **Material characteristics**

- Aluminum: An excellent heat conductor. Some types of food may cause the aluminum to darken. However, anodized aluminum cookware resists staining and pitting.
- Copper: An excellent heat conductor but discolors easily.
- Stainless steel: A slow heat conductor with uneven cooking performance, but is durable, easy to clean, and resists staining.
- Cast-Iron: A poor conductor but retains heat very well.
- Enamelware: Heating characteristics depend on the base material.
- Glass: A slow heat conductor. Use only glass cookware that is specified for range top cooking or oven use.

### **Size limitations**

#### **CAUTION**

- Do not place a small pan or pot with a bottom diameter of about 6 inches or less.
- Do not use an oversized pan. The burner flames may spread out, causing damage nearby.
- Always make sure cookware handles are turned to the side or rear of the cooktop and not over other surface burners. This will minimize the chance of burns, spillovers, and the ignition of flammable materials that can be caused if pots or pans are bumped accidentally.
- When using glass cookware, make sure it is designed for range top cooking.

- Never leave plastic items on the cooktop. Hot air from the vent can melt or ignite plastic items or cause build up of dangerous pressure in closed plastic containers. You may get severe burns if you touch the surfaces near the vent while the oven is operating.
- Make sure you hold the handle of a wok or a small one-handed pot while cooking.

## Griddle

The removable coated griddle provides an extra cooking surface. This is useful especially when cooking meat, pancakes, or other foods requiring a large cooking area.

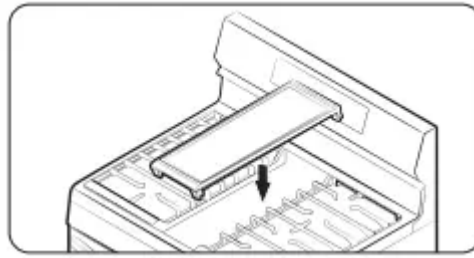

The griddle can be used only with the center burner on the center grate. Use caution when putting the griddle on the center grate.

In most cases, you should preheat the griddle before cooking. See the table below.

### **Type of Food -- Preheating Time -- Preheat setting--- Cook setting**

Pancakes -- 5-10 min. -- MED-HI -- MED

Hamburgers -- 5-10 min.-- HI -- HI

Fried Eggs -- 5-10 min. -- HI -- MED-HI

Bacon -- 5-10 min. -- HI -- HI

Breakfast Sausages -- 5-10 min. -- HI -- HI

### CAUTION

- Do not remove the griddle until the cooktop grates, surfaces, and griddle itself cool down.
- If you leave the griddle on the cooktop, it may become very hot when you use the cooktop or oven. Use oven gloves when placing or removing the griddle.
- Do not overheat the griddle. This can damage the coating of the griddle.
- Do not use metal utensils that can damage the griddle surface.
- Do not use the griddle for other purposes, for example, as a cutting board or a storage shelf.
- Do not cook excessively greasy foods. The grease may spill over.

### NOTE

- You may need to adjust heat settings for the griddle over time.
- The griddle may discolor over time as it becomes seasoned with use.
- Do not let rust remain on the griddle. If rust appears on the griddle, remove it as soon as possible.

## Gas oven



**STEP 1** Put all ingredients in a heat-safe container.

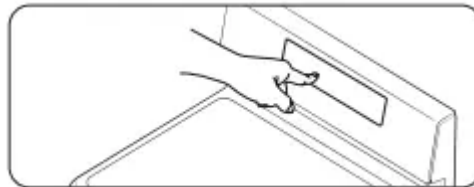

**STEP 2** Select a cooking mode, and then start preheating.



**STEP 3** Place the container on a rack.

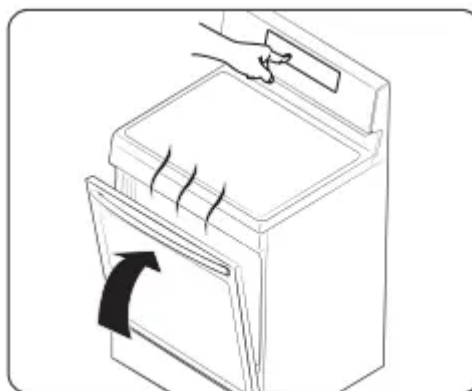

**STEP 4** Close the door and start cooking.

 **NOTE**

- The cooling fan automatically runs for a certain amount of time after cooking is complete.
- There can be a slight popping sound during oven cooking. This sound may occur during normal oven burner cycling, when the oven burner flame is extinguished.

## Using the oven racks

### The rack positions

Your oven range comes with 2 racks and 7 rack positions. The rack positions are delineated by rack guides which support the racks. Each rack guide has a stop that prevents the rack from loosening during the oven's operation. Each rack has stoppers that need to be placed correctly on the rack guides. The stoppers prevent the racks from accidentally coming out of the oven completely when you pull the racks out.

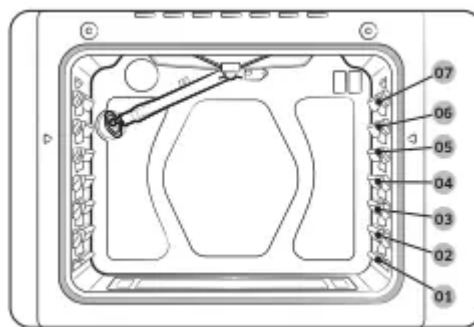

### Type of food -- Rack position

Broiling hamburgers -- 6

Broiling meats or small cuts of poultry, fish -- 4-5

Bundt cakes, Pound cakes, Frozen pies, casseroles -- 3-4

Fresh Pizza, Angel food cakes, Small roasts -- 2

Turkey, Large roasts, Hams -- 1

### CAUTION

- Do not cover an oven rack with aluminum foil. This will hamper heat circulation, resulting in poor baking.
- Do not place aluminum foil on the oven bottom. The aluminum can melt and damage the oven.
- Arrange the oven racks only when the oven is cool.
- When placing an oven rack in the top-most rack position (position 7), make sure the rack is situated stably on the embossed stop.

### NOTE

- The Oven Rack Settings table is for reference only.

- We recommend cooking pizza and pies using the 2nd rack position for crispy bottoms.
- Inserting and removing an oven rack

To insert an oven rack

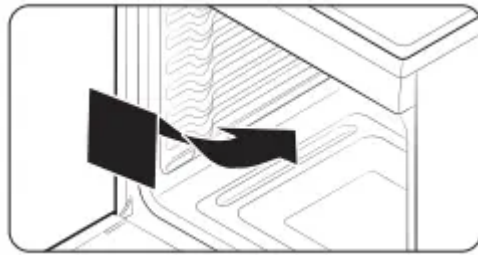

1. Place the rear end of the rack on a rack guide.
2. Slide the rack into the rack guide while holding the front end of the rack.

To remove an oven rack

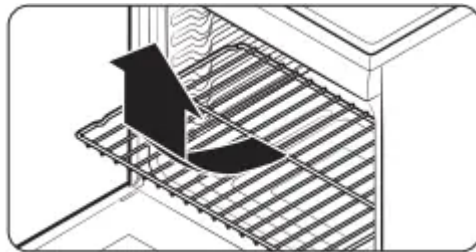

1. Pull out the rack until it stops.
2. Pull up the front end of the rack and remove it from the rack guide.

**Rack and Pan placement**

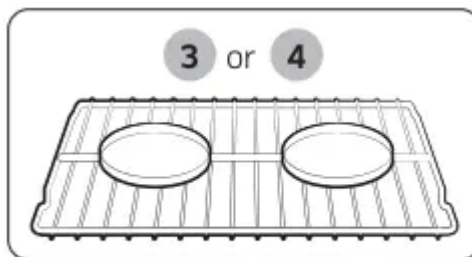

Single Oven Rack

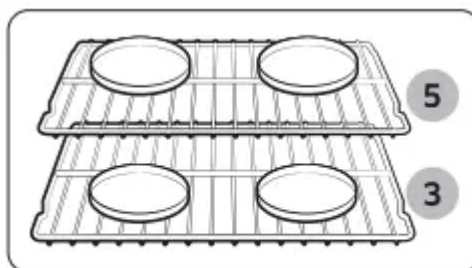

Cake pan positions



Centering the baking pans in the oven as much as possible will produce better results. If baking with more than one pan, place the pans so each has at least 1" to 1½" of air space around it. When baking on a single oven rack, place the oven rack in position 3 or 4. See the figure on the left.

When baking cakes and cookies on multiple racks, place the oven racks in positions 3 and 5. See the figure on the left.

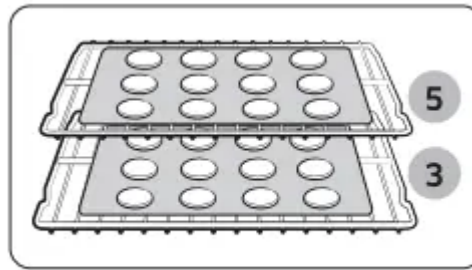

Cookie sheet positions

### Using Multiple Oven Racks

Type of Baking	Rack Positions
Cakes	3 and 5
Cookies	3 and 5

### Cooking mode

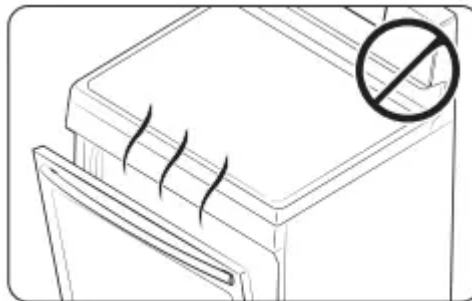

- Make sure to close the door before you start cooking.
- If you leave the door open for 20-30 seconds while the oven is in convection baking/roasting, baking, or broiling modes, the oven burner shuts off. To restart the burner, close the door.

### Minimum and maximum settings

All the features listed in the table below have minimum and maximum time or temperature settings. A beep will sound each time a pad on the control panel is pressed and the entry is accepted. An error tone will sound in the form of a long beep if the entered temperature or time is below the minimum or above the maximum setting for the feature.

Feature	Temperature (°F)	
	Min	Max
Bake	175	550
Broil	LO	HI

## Baking

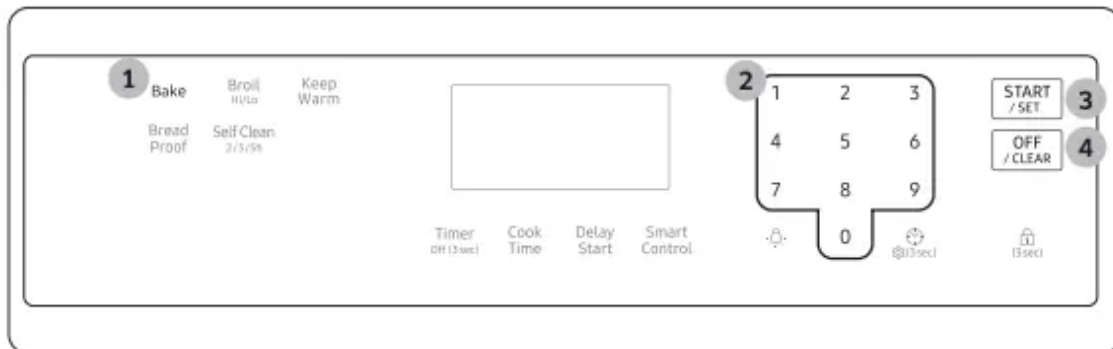

1. Press Bake.
2. If necessary, use the number pad to change the default temperature. You can set the oven to any temperature from 175 °F to 550 °F.
3. Press START/SET.
  - The oven preheats until it reaches the temperature you set. • It will beep when it reaches the set temperature.
  - When preheating is complete, place the food in the oven, and then close the door.
4. When cooking is complete, press OFF/CLEAR, and then take out the food.

 **NOTE** To change the temperature during cooking, repeat steps 1 through 3 above.

## Broiling

Broiling uses the oven broil burner at the top of the oven to cook and brown food. Meat or fish must be put on a broiling grid in a broiling pan. Preheating for 5 minutes before broiling is recommended.

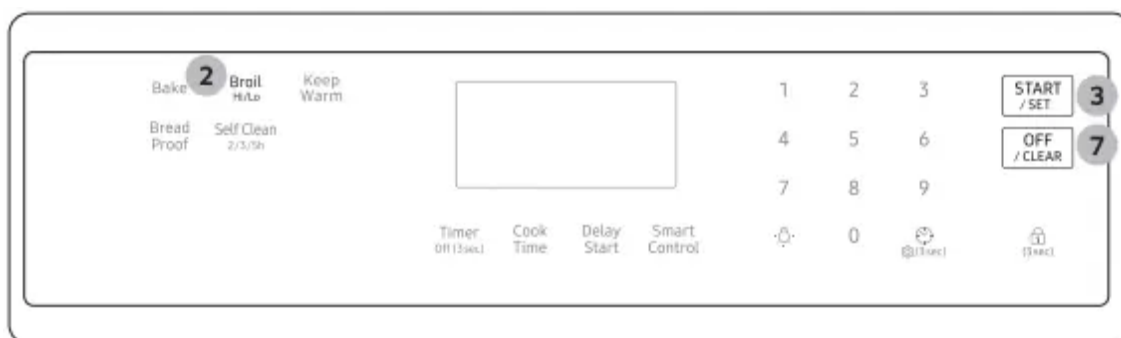

1. Put food on a broiling grid in a broiling pan.
2. Press Broil once for Hi temperature broiling or twice for Lo.
3. Press START/SET to start the broiler.
4. Let the oven pre-heat for 5 minutes.
5. Place the pan on the desired rack, and then close the oven door.
6. When one side of the food is browned, turn it over, close the oven door, and start cooking the other side.
7. When cooking is complete, press OFF/CLEAR.

 **NOTE**

- Make sure to close the door before you start cooking.
- Use the low temperature setting for poultry or thick cuts of meat to prevent overbroiling.
- In general, to prevent overbroiling, press Broil to switch from Hi to Lo.
- Use caution when you open the oven door to turn over the food. The air escaping from the oven will be very hot.
- For information about broiler temperatures, rack settings, and cooking times for different foods, see "Broiling guide" on page 24.
- Use the broil rack for the best results.

### **Broiling guide**

 **NOTE**

- This is for reference only.
- Preheating for 5 minutes before broiling is recommended.
- The size, weight, thickness, starting temperature, and your doneness preference will affect broiling times.
- This guide is based on meats at refrigerator temperature.
- If you have covered the meat with aluminum foil and you let it stand covered for 10 minutes after cooking is complete, the internal temperature increases by 5-10 °F degrees.
- Use the broil rack for the best results.

Food	Doneness	Size	Thickness	Broil setting	Rack position	Cooking time	
						1st side	2nd side
Hamburgers	Medium	9 patties	1"	HI	6	4'30"-5'30"	3'30"-4'30"
Beef steak	Medium	1 pc	1"	HI	5	8'00"-10'00"	6'00"-8'00"
Chicken pieces	Well done	2-3 lbs.	¾"-1"	Lo	4	18'00"-20'00"	11'00"-13'00"
Salmon Fillets	Well done	3-4 pcs	½"-¾"	HI	5	6'00"-7'00"	5'00"-6'00"
Pork chops	Well done	1-2 pcs	½"-¾"	Lo	4	12'00"-14'00"	12'00"-15'00"
Lamb chops	Medium	4-6 pcs	1"	HI	5	5'00"-6'00"	4'00"-5'00"

**⚠ CAUTION** Make sure to close the door after turning over the food.

## Cooking options

**⚠ CAUTION** Food that can easily spoil, such as milk, eggs, fish, poultry, and meat, should be chilled in a refrigerator before they are placed in the oven. Even when chilled, they should not stand for more than 1 hour before cooking begins and should be removed promptly when cooking is completed.

## Timer

The kitchen timer gives you an extra timer you can use to time cooking tasks such as boiling eggs. It does not, however, start or stop any cooking operation. You can set the timer from 1 minute to 9 hours and 59 minutes.

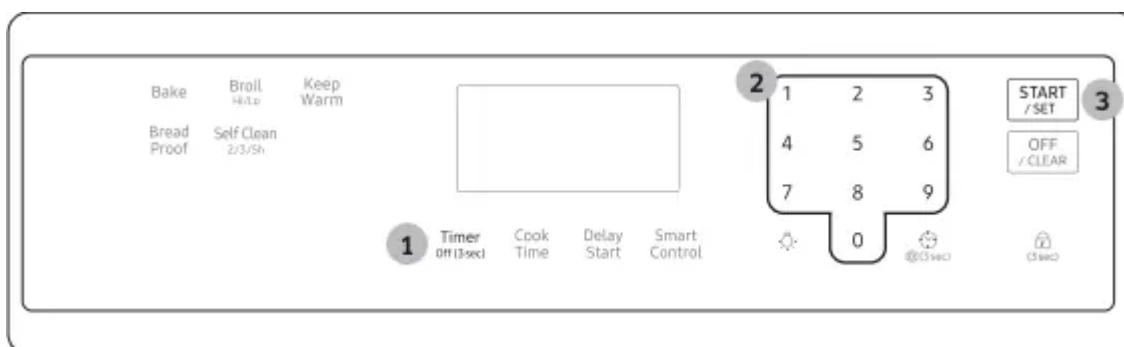

1. Press Timer Off (3 sec).
2. Enter a desired time using the number pad.
3. When done, press START/SET.
4. To cancel the Timer settings, press and hold Timer Off (3 sec) for 3 seconds.

5. When the set time elapses, the oven beeps and displays the “End” message. Press OFF/ CLEAR to delete the message.

**NOTE** To change the programmed cooking time, press Timer Off (3 sec), enter a different time, and then press START/SET.

## Cook Time

Cook Time sets the oven to cook foods at a set temperature for a set length of time. The oven automatically turns off when it finishes.

**Mode:** Bake

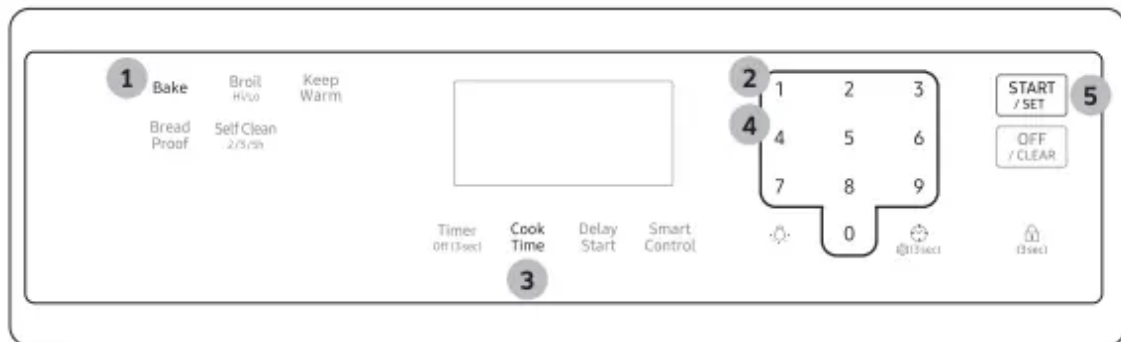

1. Press the pad corresponding to a desired cooking mode such as Bake.
2. If necessary, change the temperature using the number pad.
3. Press Cook Time.
4. Set the cooking time between 1 minute and 9 hours and 59 minutes (9:59) using the number pad.
5. Press START/SET. The oven will automatically turn on and start preheating. The temperature will increase until it reaches the temperature you set. The oven starts cooking for the amount of time you set.
6. When preheating is complete, put the container with the food on a rack, and then close the door.
7. When the cooking time has elapsed, the oven will automatically shut off and then beep.

## **NOTE**

- To change the programmed cooking time, press Cook Time, enter a different time, and then press START/SET.
- If necessary, press Keep Warm after setting the cooking time. Then, Keep Warm will start when the cooking time has elapsed.

## Delay Start

The Delay Start function lets you use the kitchen timer to automatically start and stop another cooking program. You can set Delay Start so that it delays the automatic start of a cooking operation you select by up to 12 hours. **Mode:** Bake / Self Clean

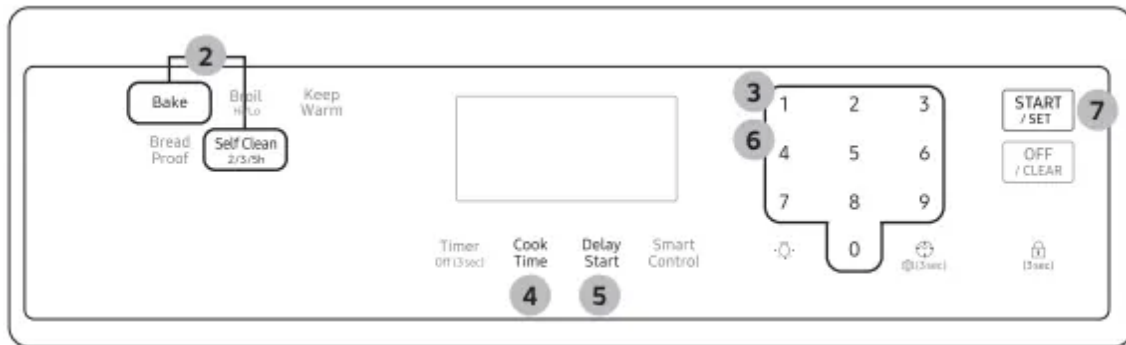

1. Place the container with the food on a rack, and then close the door.
2. Press the pad corresponding to a desired cooking mode such as Bake.
3. If necessary, change the temperature using the number pad.
4. If necessary, press Cook Time and set the cooking time. (See "Cook Time" on previous page.)
5. Press Delay Start to change the time elements.
6. Set the starting time using the number pad.
7. Press START/SET.
8. The oven starts cooking at the set time, and turns off automatically when it completes cooking.

**NOTE** To change the starting time, press Delay Start, and enter a new starting time, and then press START/SET.

## Special features

### Keep Warm

Keep cooked food warm at a low temperature for up to 3 hours.

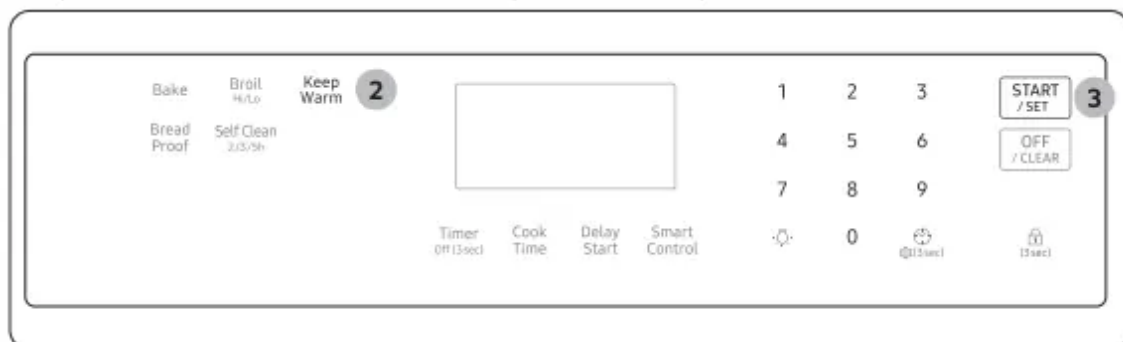

1. Place the container with the food on a rack, and then close the door.

2. Press Keep Warm.

3. Press START/SET. The oven heats up to 175 °F (80 °C).

## NOTE

- You can cancel warming at any time by pressing OFF/CLEAR.
- To set the warming function during a timed cooking, press Keep Warm in timed cooking mode. When the timed cooking is complete, the oven will lower the temperature to the warming default, and keep that temperature until the warming finishes or is canceled.

## Bread Proof

The Bread Proof function automatically provides the optimum temperature for the bread proof process, and therefore does not have a temperature adjustment. If you press Bread Proof when the oven temperature is above 100 °F, Hot will appear in the display. Because this function produces the best results when started while the oven is cool, we recommend that you wait until the oven has cooled down and Hot disappears from the display.

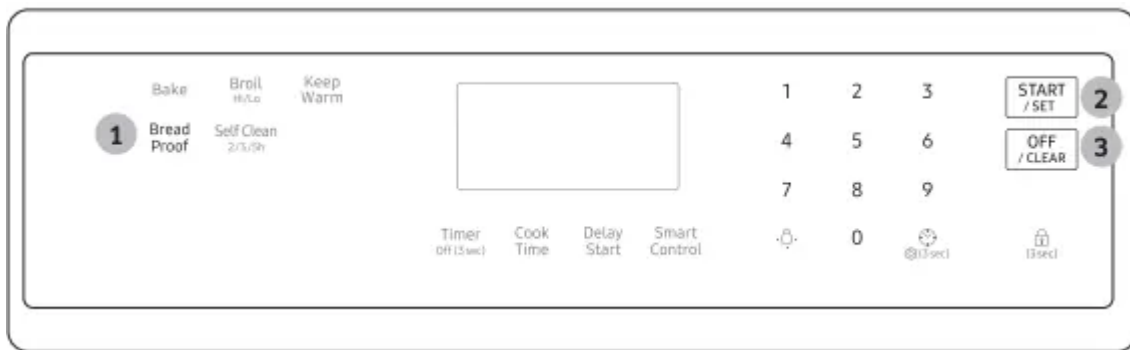

1. Press Bread Proof.

2. Press START/SET.

3. Press OFF/CLEAR at any time to turn off the Bread Proof function.

 NOTE Use rack position 3 for bread proofing.

## CAUTION

- Do not use Bread Proof when the oven temperature is above 125 °F. If the temperature is above 125 °F, this mode will not heat the oven to the optimal temperature. Wait until the oven cools down.
- Do not use Bread Proof for warming food. The proofing temperature is not hot enough to keep food warm.
- Place the dough in a heat-safe container on rack position 3 or 4 and cover it with a cloth or with plastic wrap. You may need to anchor the plastic wrap underneath the container so that the oven does not blow it off the dough.

- To avoid lowering the temperature and extending proofing time, do not open the oven door.

## The Sabbath Option



(For use on the Jewish Sabbath and Holidays) Use this option only for baking on the Jewish Sabbath and Holidays. For more information, visit the website at <http://www.star-k.org>

### With the Sabbath option

- The oven temperature can be set higher or lower after you have set this option.
- The display doesn't change and the oven will not beep when you change the temperature.
- Once the oven is properly set for baking with the Sabbath option active, the oven will remain continuously on until the Sabbath feature is cancelled. This will override the factory preset 12 hour energy saving feature.
- If the oven light is needed during the Sabbath, press  before activating the Sabbath feature. Once the oven light is turned on and the Sabbath option is active, the oven light will remain on until the Sabbath option is turned off.
- If you want the oven light off, be sure to turn it off before activating the Sabbath feature.
- Do not use the surface cooktop when the Sabbath option is on.

### To enable the Sabbath option

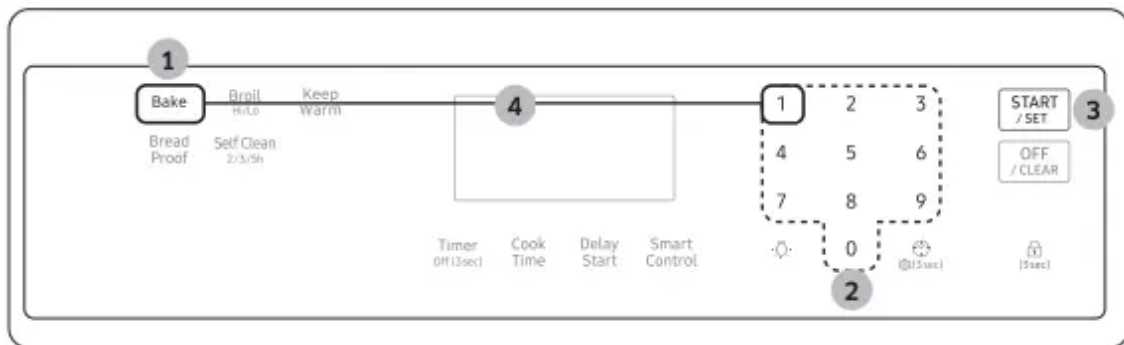

1. Press Bake.
2. Enter a desired temperature using the number pad. The default temperature is 350 °F.
3. Press START/SET. The display temperature changes after the oven temperature reaches 175 °F.
4. Press Bake and Number 1 simultaneously for 3 seconds to display "SAb". Once "SAb" appears, the oven control no longer beeps or displays any further changes.

### NOTE

- You can change the oven temperature once baking starts, but the display will not change or beep. After changing the temperature, it takes 15 seconds before the oven recognizes the change.
- You can turn off the oven at any time by pressing OFF/CLEAR. However, this doesn't deactivate the Sabbath option.
- To deactivate the Sabbath option, hold down Bake and Number 1 simultaneously for 3 seconds.
- You can set the cooking time before activating the Sabbath option.
- After a power failure, the oven will not resume operation automatically. "SAb" will appear in the control panel, but the oven will not turn back on. Food can be safely removed from the oven, but you should not turn off the Sabbath option and turn the oven back on until after the Sabbath/Holidays.
- After the Sabbath observance, turn off the Sabbath option by pressing and holding Bake and Number 1 simultaneously for at least 3 seconds.

### CAUTION

- Do not attempt to activate any other functions except for Bake when the Sabbath option is on. Only the following pads will function properly: Number pads, Bake, Oven Start/Set, and Oven Off.
- Do not open the oven door or change the oven temperature for about 30 minutes after you have started the Sabbath option. Let the oven reach the set temperature. The oven fan operates only when the oven temperature increases.

### Oven lock

Lock the control panel and the door to prevent accidental operations and/or product tipping.

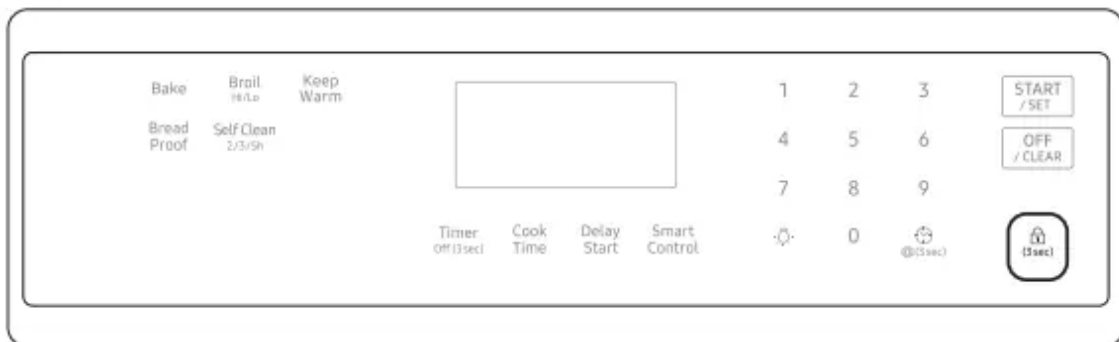

Press and hold the  for 3 seconds to lock or unlock both the control panel and the door. When the Oven Lock is on, the oven panel does not operate and the oven door is locked and cannot be opened.

## Changing settings

Press and hold  for 3 seconds to change various settings of the range to your preference. The Setting menu is available only when the oven is off.

	Setting	Description
0	Demo mode	Used by retailers for display purposes only.
1	Temperature adjust	Recalibrate the oven temperature.
2	Temperature unit (°F / °C)	Set the oven control to display temperatures in Fahrenheit or Celsius.
3	Energy saving	Automatically turns off the oven 12 hours after baking starts or 3 hours after broiling starts.
4	Sound	Turn the oven's sound (beeps) on or off.
5	WI-FI On/Off	Set the WI-FI mode to ON/Off

### Demo mode

This is used by retailers for display purposes only. In this mode, the heating element does not operate.

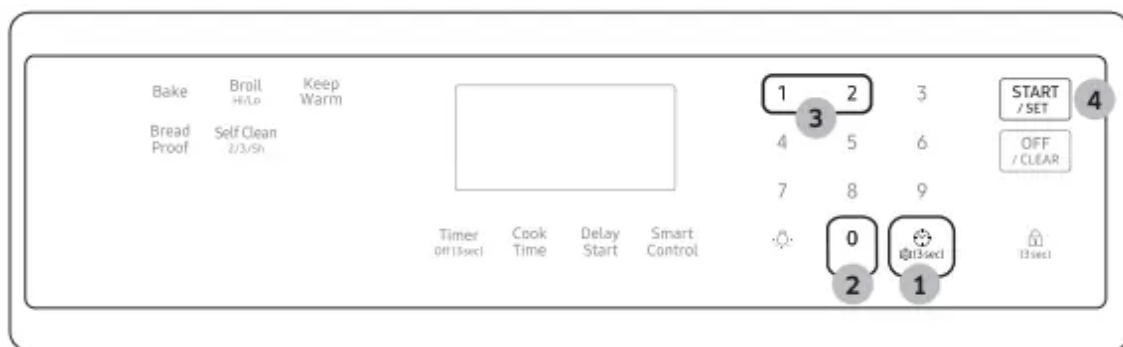



1. Press and hold  for 3 seconds.
2. Press 0 to enter Demo mode.
3. Press 1 or 2 to turn Demo mode on or off. (1 to on, 2 to off)
4. Press START/SET to save the change.

### Temperature adjust

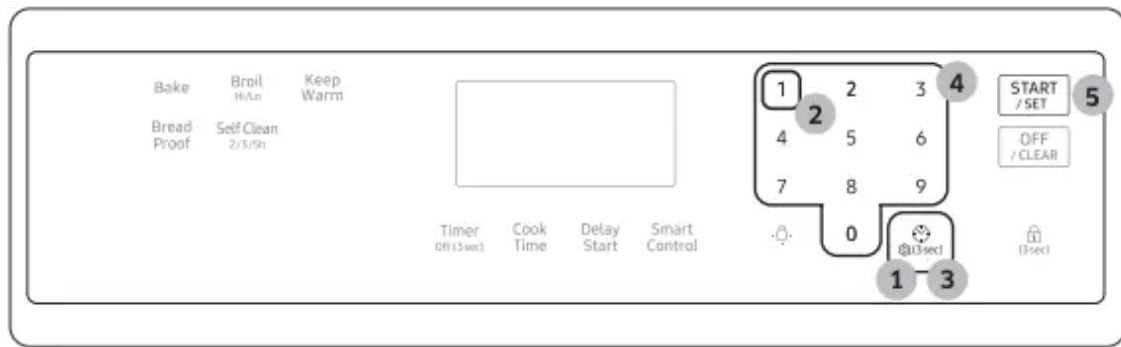
The oven temperature has been calibrated at the factory. When first using the oven, follow the recommended recipe times and temperatures. If it appears that the oven is too hot or too cool, you can recalibrate the oven temperature. Before recalibrating, test a recipe by using a temperature setting that is higher or lower than recommended. The baking results should help you decide how much of an adjustment is needed. The oven temperature can be adjusted by  $\pm 35$  °F ( $\pm 19$  °C).



1. Press and hold  for 3 seconds.
2. Press 1 to enter Temperature adjust.
3. Press  to select a higher(+) or lower(-) temperature.
4. Enter and adjusting temperature value (0-35) using the number pad.
5. Press START/SET to save the change.

 **NOTE** This adjustment does not affect the broiling or the self-cleaning temperature, and is retained in memory after a power failure

## Voice control

To use the Range's Voice Control function, you need Bixby / Amazon Alexa App / Google Assistant App on your mobile device. Refer to the table below for all available functions.

### Bixby

Start conversation with Bixby on SAMSUNG mobile by saying "Hi Bixby" or by pressing the side key.

### Turn Off/Stop

- Cancel the range(oven).
- Turn off the range(oven).
- Stop baking in the range(oven).

### Check Temp

- What is the temperature of the range(oven)?
- Check the range(oven) temperature.

### Check Time

- Check the remaining time of the range(oven).
- How much range(oven) time is left on the timer?
- How much time is left on the range timer?

### **Check Mode (States)**

- Check the range status.
- Check the status of the range(oven).

### **Temp Control**

- Set the temperature of the range(oven) to 300.
- Increase the temp of the range(oven) by 20.
- Decrease the temp of the range(oven) by 20.
- Turn the range(oven) temperature up to 100 degrees.
- Turn the range(oven) temperature down to 50 degrees.

### **Oven Light**

- Turn on the oven light (lamp).
- Turn on the range oven light.
- Turn off the oven light (lamp).
- Turn off the range oven light.

### **Oven Timer (Cook Time)**

- Set the timer on the range(oven) to 1 hour.

### **Amazon Alexa & Google Assistant**

Samsung smart home appliances are supported by SmartThings skill in Alexa & action in Google Assistant.

#### Installation Guide

Here's how to link SmartThings account into Amazon Alexa or Google Assistant. SmartThings App and Alexa App(or Google Assistant App) Should be installed on your phone.

1. Setup the supported devices to SmartThings.
2. After device setup, tap + button on the screen.
3. Tap 'Voice assistant' and link your Samsung account to Amazon Alexa. (or Google Assistant)
4. Check the devices are visible on Amazon Alexa app. Then account linking is complete. (Check the devices are visible and set the location(home&room) of devices in Google home app. Then account linking is complete.)

### **Function Turn Off/ Stop**

#### **“Alexa”**

- Turn off the oven[Device name].

- Stop the oven[Device name].

**“Ok Google”**

- Turn off the oven[Device name].
- Stop the oven[Device name].

**Function Check Temp**

**“Alexa”**

- What is the temperature of the oven[Device name]?

**“Ok Google”**

- What is the temperature of the oven[Device name]?

**Function Check Time**

**“Alexa”**

**“Ok Google”**

- • What time is left on the oven[Device name]?

**Function Check Mode (States)**

**“Alexa”**

- Is the oven[Device name] running?
- Is the oven[Device name] on?

**“Ok Google”**

- Is the oven[Device name] running?
- What mode is the oven[Device name] set to?

**Function Temp Control**

**“Alexa”**

- Set oven[Device name] to 300 degrees [Temp].

**“Ok Google”**

- Set oven[Device name] to 300 degrees [Temp].

**Function Oven Timer (Cook Time)**

**“Alexa”**

- Set oven[Device name] to 3 hours[Time].
- Add 10 minutes/hours[Time] to the oven[Device name].

**“Ok Google”**



- Set oven[Device name] to 3 hours[Time].
- Add 10 minutes/hours[Time] to the oven[Device name].

 **NOTE** On/Off spec of smart control is same as guided in SmartThings app.

## Maintenance



### Cleaning

#### CAUTION

- Wear the glove during cleaning.

### Control panel

First, lock the control panel and the door to prevent accidental operations and/or product tipping.

1. Press and hold  for 3 seconds to lock both the control panel and the door.
2. Clean the control panel using a soft cloth dampened with plain water, warm soapy water, or glass cleaner. Do not spray cleansers directly onto the control panel.
3. When done, press and hold  again for 3 seconds.

### WARNING

- Make sure the control panel turns off and all surfaces of the range are cool before cleaning. Otherwise, you can get burned.
- If the range has been moved away from the wall, make sure the Anti-Tip device is reinstalled properly when the range has been put into place again. Otherwise, the range may tip over, causing physical injuries.
- Do not use steel-wool or abrasive cleansers of any kind. These can scratch or damage the surface.

### Stainless steel surface

1. Remove any spills, spots, and grease stains using a soft, wet cloth.
2. Apply an approved stainless steel cleanser to a cloth or paper towel.
3. Clean one small area at a time, rubbing with the grain of the stainless steel if applicable.
4. When done, dry the surface using a soft, dry cloth.
5. Repeat steps 2 through 4 as many times as necessary.

## CAUTION

- Do not use a steel-wool pad or abrasive cleanser on stainless steel surfaces. It will scratch the surface.
- Do not spray any type of cleanser into the manifold holes. The ignition system is located in those holes and must be kept free of moisture.

## Racks

To keep the racks clean, remove them from the cavity, and soak them in lukewarm soapy water. Then, scour soil off of the racks using a plastic scouring pad. If the racks do not slide in and out smoothly after you have cleaned them, rub the side rail guides with wax paper or a cloth containing a few drops of cooking oil. This will help the racks glide more easily on their tracks.

## NOTE

- Do not put the racks in a dishwasher.
- If a rack does not slide in and out smoothly, apply a few drops of cooking oil to the oven rack guides.
- If a rack becomes too difficult to slide in or out, lubricate the rack with graphite lubricant.
- To purchase the graphite lubricant, contact us at 1-800-SAMSUNG (726-7864).
- For online shopping, visit <http://www.samsungparts.com/Default.aspx> and search for part DG81-01629A.

## CAUTION

- Do not leave the racks in the oven during the self-cleaning cycle. The extreme heat generated in this cycle can permanently peel off the rack coating and make it difficult to slide the racks on the guide rails.
- Do not spray cooking oil or lubricant directly onto the racks.

## Oven

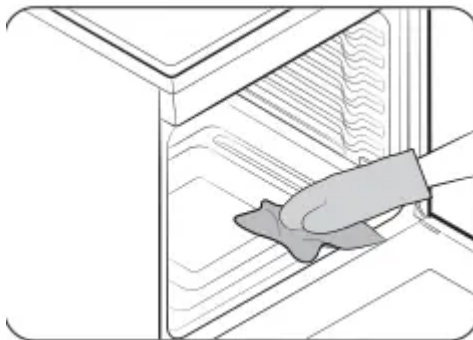

- Wear the glove during cleaning.

## Door

Do not remove the inner gasket of the oven door for cleaning

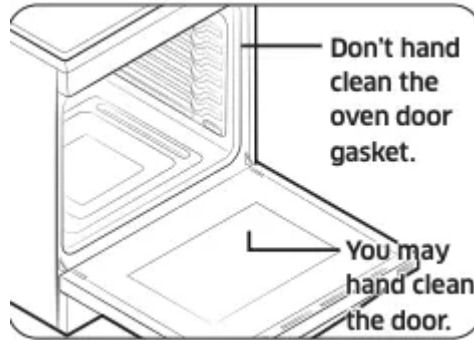

- Use soap and water to thoroughly clean the top, sides, and front of the oven door. Rinse well. You may use a glass cleaner on the outside glass of the oven door. DO NOT immerse the door in water. DO NOT spray or allow water or the glass cleaner to enter the door vents. DO NOT use oven cleaners, cleaning powders, or any harsh abrasive cleaning materials on the outside of the oven door.
- DO NOT clean the oven door gasket. The oven door gasket is made of a woven material which is essential for a good seal. Care should be taken not to rub, damage, or remove this gasket.

#### Door inner side

- Inner surface: Clean the inner side of the door manually using a soapy plastic scouring pad, and then wipe with a dry cloth. Take care not to get the gasket wet or allow moisture into the door.
- Inner glass: The inner glass is cleaned automatically during the self-cleaning cycle.

#### Door outer side

- Outer surface: Follow the cleaning instructions for the stainless steel surface in the previous section.
- Outer glass: Clean the outer glass using a glass cleanser or soapy water. Rinse and dry thoroughly. Take care not to get the gasket wet or allow moisture into the door.

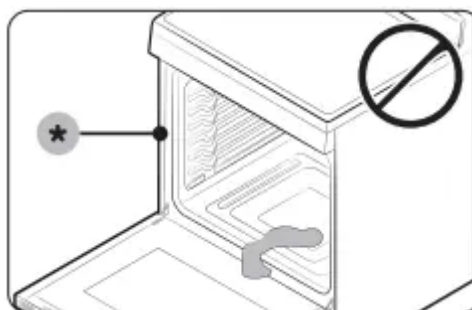

 CAUTION

Do not let moisture enter the door or contact the door gasket. Moisture may reduce the gasket's performance.

### **Burner controls**

Make sure all surface burner knobs are in the OFF position

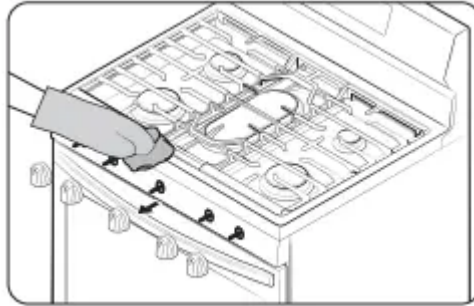

1. Pull knobs off the control valve stems.
2. Clean the knobs in warm, soapy water. Then, rinse and dry them thoroughly.
3. Clean the stainless steel surfaces using stainless steel cleaner.
4. Re-attach the knobs to the control valve stems.

### **CAUTION**

- Do not clean the control knobs in a dish washer.
- Do not spray cleansers directly onto the control panel. Moisture entering the electric circuits may cause electric shock or product damage.

### **Cooktop surface**

The porcelain-enameled cooktop surface needs to be kept clean. We recommend that you remove food spills immediately after they take place.

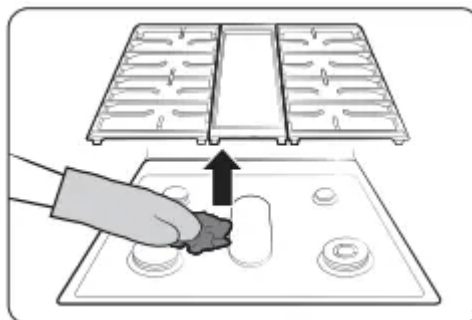

1. Turn off all surface burners.
2. Wait until all burner grates cool down, and then remove them.
3. Clean the cooktop surface using a soft cloth. If food spills run into gaps of the burner components, remove the burner cap and the head, and wipe up the spills.

4. When cleaning is finished, reinsert the burner components, and then put the burner grates back into position.

 **CAUTION**

- Do not use a steel-wool pad or abrasive cleaner, which can scratch or damage the enamel surface.
- Do not remove the cooktop surface to clean it. The gas lines leading to the burner manifolds can be damaged, resulting in a fire or system failure.
- Do not pour water into the cooktop well while cleaning the cooktop. This could leak down into the range gas and electrical systems creating a risk of electrical shock or high levels of carbon monoxide due to corrosion of the gas valves or ports.
- Keep oven vent ducts unobstructed. Clean vents frequently to avoid grease buildup.

### **Burner grates and components**

Turn off all surface burners and make sure they have all cooled down.

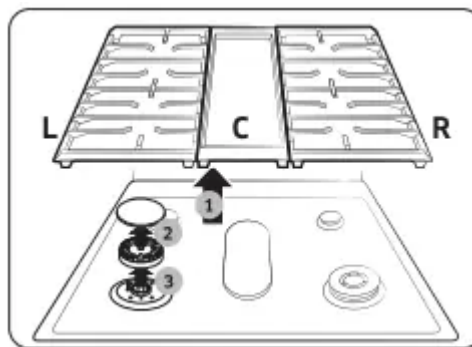

1. Remove the center burner grate(C) following both sides grates.(L/R)
2. Remove the burner caps from the burner heads.
3. Remove the burner heads from the valve manifolds to reveal the starter electrodes.
4. Clean all removable grates and burner components in warm, soapy water. Do not use steel-wool pads or abrasive cleaners.
5. Rinse and dry grates and burner components thoroughly.
6. Return the burner heads to their positions on top of the manifold valves. Make sure a starter electrode is inserted through the hole in each burner head.



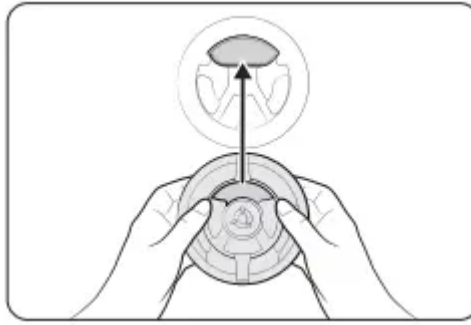

Install the burner head so that the electrode passes through the opening for the electrode. Make sure the burner head lies flat on the stove top.

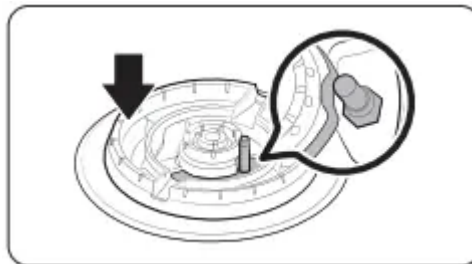

### Round Burner head

1. Orient the burner head so that the opening for the electrode lines up with the electrode.



2. Install the burner head so that the electrode passes through the opening for the electrode. Make sure the burner head lies flat on the stove top.

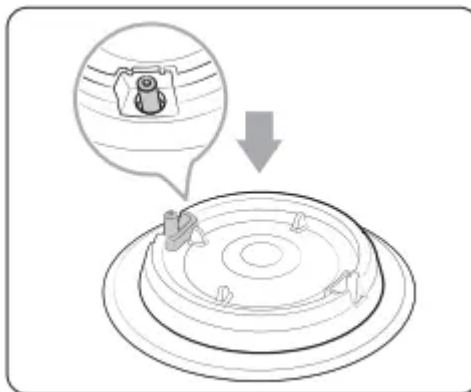

### Oval burner

1. Orient the burner head so that the opening for the electrode lines up with the electrode.

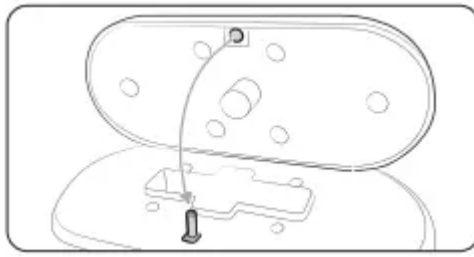

2. Install the burner head so that the electrode passes through the opening for the electrode. Make sure the burner head lies flat on the stove top.

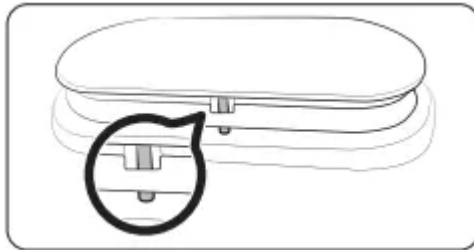

### Burner Cap

1. Match the burner caps to the burners by size, and then reinstall the caps on the burner heads.

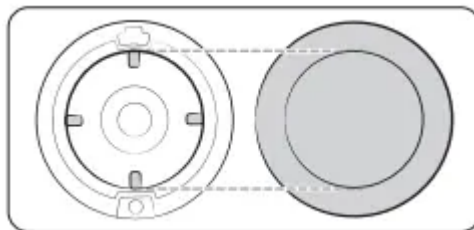

**⚠ CAUTION** Make sure each cap is reinstalled on the correct burner head, is centered on the burner head, and lies flat.

**⚠ CAUTION** Make sure all burner components (heads and caps) are reinstalled properly. They will be stable and rest flat when correctly installed.

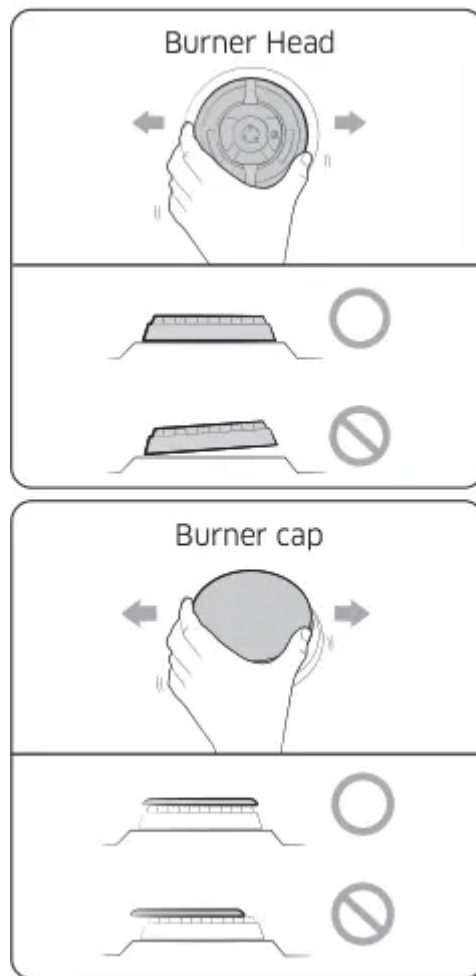

## Self-cleaning

This self-cleaning oven uses high temperatures (well above cooking temperatures) to burn off leftover grease and residue completely or reduce them to a finely powdered ash that you can wipe away with a damp cloth.

### CAUTION

- Do not leave small children unattended near the range during the self-cleaning cycle. The outside surfaces of the range can get extremely hot.
- Some birds are extremely sensitive to fumes from a self-cleaning oven. Relocate birds to a well-ventilated room away from the range.
- Do not line the oven, oven racks, or oven bottom with aluminum foil. Doing so will result in poor heat distribution, produce poor baking results, and cause permanent damage to the oven interior. The aluminum foil will melt onto and adhere to the interior oven surfaces.
- Do not force the oven door open during the self-cleaning cycle. This will damage the automatic door-locking system. The door automatically locks when the self-cleaning cycle

is started and stays locked until the cycle is cancelled and the oven temperature is below 400 °F.

- Use caution when opening the oven door after the self-cleaning cycle. The gas oven will still be VERY HOT and hot air and steam might escape when the door is open.
- Wipe off any excess spillage before using the self-cleaning operation.
- Do not use oven cleaners. Commercial oven cleaners or oven liners should NEVER be used in or around any part of the oven. Residue from oven cleaners will damage the inside of the oven during a self-cleaning operation.

### To perform the self-cleaning cycle

Make sure the door lock is released. Remove all racks from the oven cavity

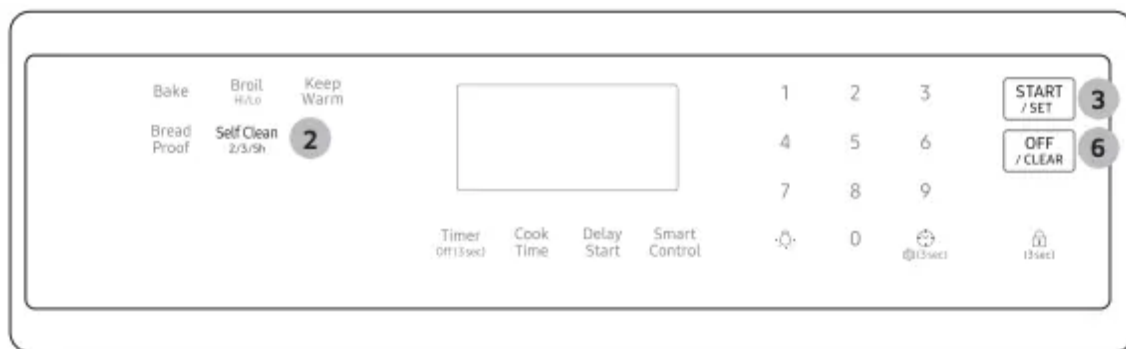

1. Make sure the oven door is closed completely and unlocked.
2. Press Self Clean once. Then, select the cleaning time by pressing Self Clean one or more times in accordance with the table below.

Once	Twice	Three times
3-hour cycle	5-hour cycle	2-hour cycle

3. Press START/SET. The oven door is locked and the oven begins to heat up.
4. When the self-cleaning cycle is complete, the oven beeps 10 times. The door will remain locked and the Lock icon will blink until the oven temperature falls below 400 °F (204 °C).
5. When the Lock icon changes to an open lock, you can open the oven door. The Lock icon changes to an open lock when the oven temperature drops below 400 °F (204 °C).
6. Press OFF/CLEAR to display the time of the day.

**⚠ CAUTION** Do not use the surface burners while the gas oven is performing a self-cleaning cycle.

**⚠ WARNING** Be sure all controls are OFF and all surfaces are COOL before cleaning any part of the range.

**NOTE** Make sure all surface burners are off while the oven is performing a self cleaning cycle. Self-clean will not operate if a surface burner is on.



### To delay starting a self-cleaning cycle

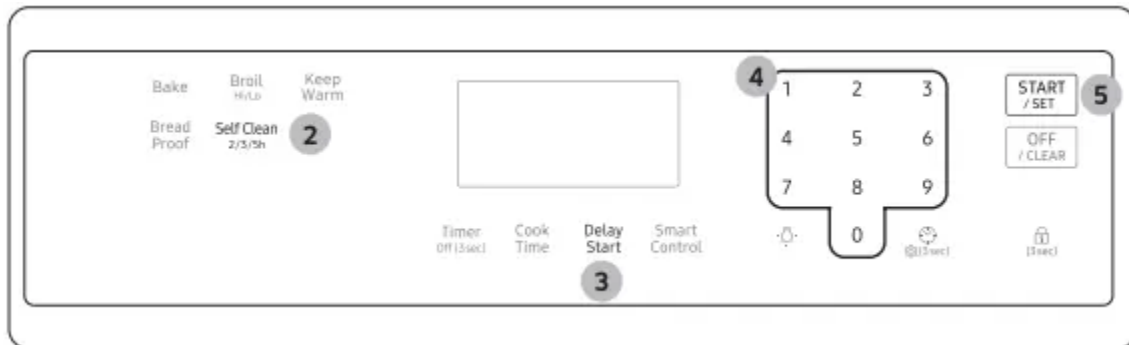

1. Make sure the oven door is closed completely and unlocked.
2. Press Self Clean once. Then, select the cleaning time by pressing Self Clean one or more times in accordance with the table below.

Once	Twice	Three times
3-hour cycle	5-hour cycle	2-hour cycle

3. Press Delay Start.
4. Set the time you want the oven to start self-cleaning using the number pad.
5. Press START/SET. The oven door locks, and the oven will start self-cleaning at your specified time.

### To cancel the self-cleaning cycle

You may find it necessary to stop or interrupt a self-cleaning cycle due to smoke in the oven. To turn off the self-cleaning cycle, press OFF/CLEAR. The cycle turns off, but the door remains locked and the Lock icon blinks until the oven temperature falls below 400 °F (204 °C).

### After self-cleaning

- The door stays locked until the internal oven temperature falls below 400 °F.
- When the oven has cooled down, wipe the oven surfaces with a cloth to remove ash residue.

- Stubborn stains can be removed using a steel-wool pad. Lime deposits can be removed using a vinegar-soaking cloth.
- If you are not satisfied with the cleaning results, repeat the cycle. “HOT” appears on the display until the oven cools down. Wait until the message disappears, and then start a new cycle.
- The cooling fan automatically runs for certain amount of time after self-cleaning.
- Self-cleaning does not operate within 2 hours after running the self-cleaning cycle.

**⚠ CAUTION**

Do not attempt to open the oven door immediately after the self-cleaning cycle is complete. The oven is still very hot when the door unlocks. Escaping hot air and/or steam could burn you.

## Replacing the oven light

### Oven light

The oven light is a standard 40-watt appliance bulb. It comes on when you open the oven door.

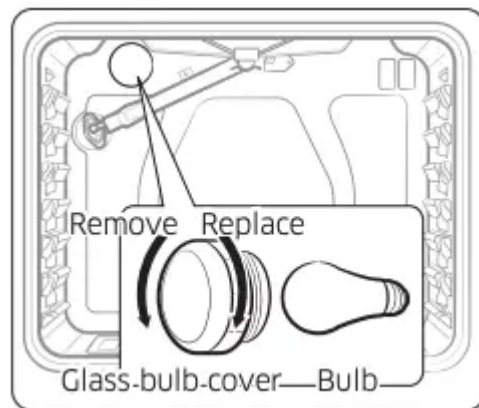

1. Turn off the oven.
2. Make sure the oven and oven light are cool.
3. Open the door, and remove the glass cover by turning it counterclockwise.
4. Remove the oven light from the socket by turning it counterclockwise.
5. Insert a new 40-watt appliance bulb into the socket, and then turn it clockwise to tighten.
6. Reinsert the glass cover, and then turn it clockwise to tighten.

**⚠ CAUTION**

To prevent electric shock, make sure the oven is turned off and cool before replacing the oven light.

**📄 NOTE**

- The oven light does not operate during the self-cleaning cycle.
- Remove the racks if they prevent you from accessing the oven light.

## Removing and reinstalling the oven door

### How to remove the door

#### CAUTION

- The door is very heavy. Be careful when removing and lifting the door. Do not lift the door by the handle.
- Turn the power OFF before removing the door.
  1. Open the door completely.
  2. Pull the hinge locks down toward the door frame to the unlocked position.

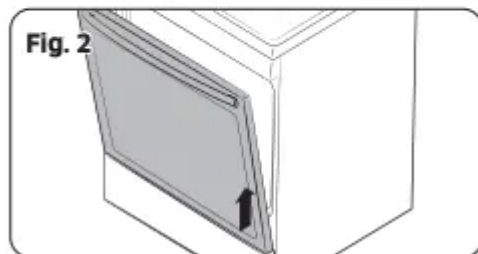
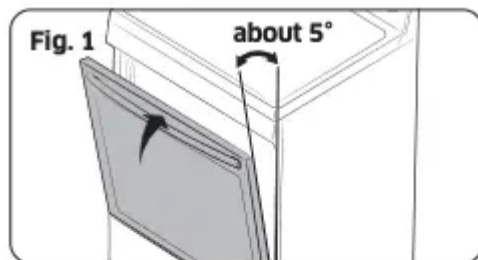
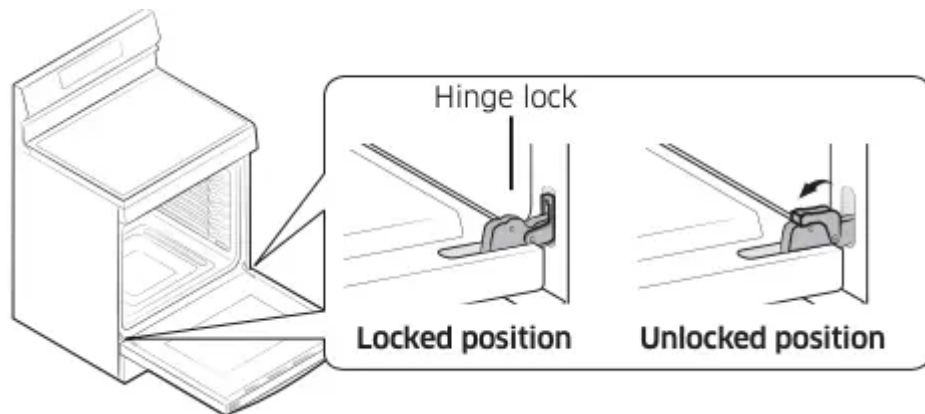

3. Firmly grasp both sides of the door at the top.
4. Close the door to the door removal position, which is approximately 5 degrees from vertical (Fig. 1).
5. Lift the door up and out until the hinge arms are clear of the slots (Fig. 2).

## How to reinstall the door

1. Firmly grasp both sides of the door at the top.
2. With the door at the same angle as the removal position, slide the indentations of the hinge arms into the bottom edges of the hinge slots. The notches in each hinge arm must be fully inserted into the bottoms of each slot.

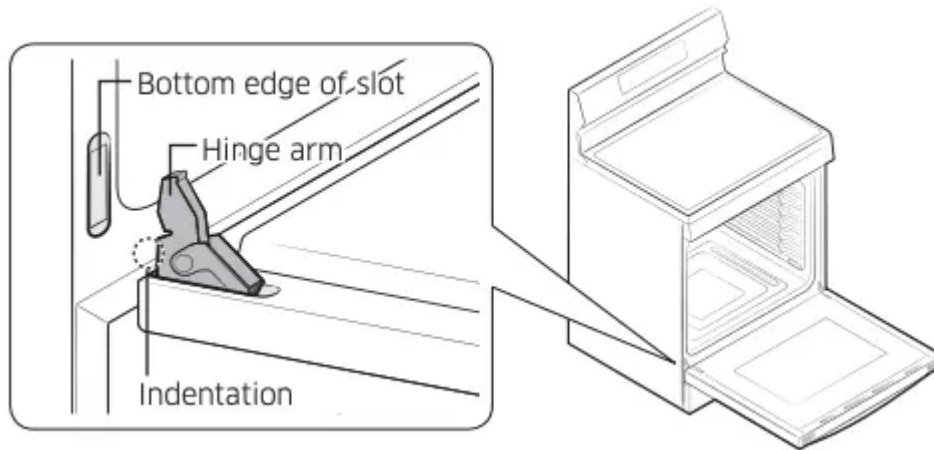

3. Open the door fully. If the door will not open fully, the indentations are not inserted correctly in the bottom edges of each slot.
4. Push the hinge locks up against the front frame of the oven cavity into the locked position.

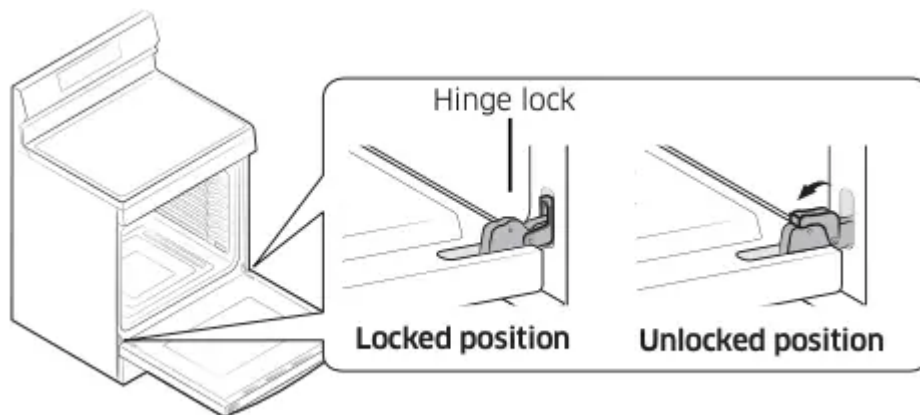

5. Close the oven door.

## How to remove and reinstall the Storage drawer

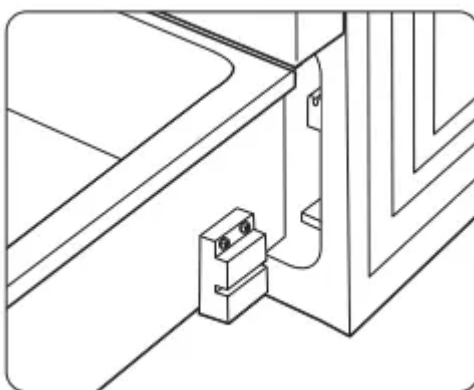

1. Slide open the drawer until it stops.
2. Pull the drawer with lifting it for removal.
3. Clean the drawer in warm, soapy water using a cloth or soft brush. Then, rinse and dry it thoroughly.
4. Push in the drawer while slightly lifting the front to close it.

## Troubleshooting

If you encounter a problem with the range, check the tables starting below, and then try the suggested actions.

### Checkpoints

#### Gas safety

##### You smell gas.

The surface burner knob is not in the OFF position and the burner is not lit.

- Turn the burner knob to OFF.

There is a gas leak.

- Clear the room, building, or area of all occupants. Immediately call your gas supplier from a neighbor's phone. Do not call from your phone. It is electrical and could cause a spark that could ignite the gas. Follow the gas supplier's instructions. If you cannot reach your gas supplier, call the fire department.

#### Surface burner

##### All burners do not light.

The power cord is not plugged into the electrical outlet.

- Make sure the electrical plug is plugged into a live, properly grounded outlet.

A fuse in your home may be blown or the circuit breaker may have tripped.

- Replace the fuse or reset the circuit breaker.

The gas supply is not properly connected or turned on.

- See the Installation Instructions that came with your range.

**Surface burners do not light.**

The control knob is not set properly.

- Push in the control knob and turn it to the Lite position.

The burner caps are not in place. The burner base is misaligned.

- Clean the electrodes. Put the burner cap on the burner head. Align the burner base.

**Surface burner clicks during operation.**

The control knob has been left in the Lite position.

- After the burner lights, turn the control knob to a desired setting. If the burner still clicks, contact a service technician.

**The burners do not burn evenly.**

Surface burner components and caps are not assembled correctly and level.

- See page 36.

The surface burners are dirty.

- Clean the surface burner components.(See page 35.)

**Very large or yellow surface burner flames.**

The wrong burner orifice is installed.

- Check the burner orifice size. Contact your installer if you have the wrong orifice (LP gas instead of natural gas or natural gas instead of LP gas).

**Surface burners light but oven burners do not light.**

The oven door lock is turned on.

- The display will show the Lock icon. Hold the oven door open and press  for 3 seconds. The oven will beep and the Lock icon will turn off.

The Gas Pressure Regulator shut off switch is in the off position.

- Call a qualified service technician.

**Oven**

**The oven control beeps and displays an information code.**

There may be an issue with your oven. See the “Information codes” chart on page 47.

- Press OFF/CLEAR, and then restart the oven. If the problem persists, disconnect all power to the range for at least 30 seconds and then reconnect the power. If this does not solve the problem, call for service.

### **The oven will not turn on.**

The oven is not completely plugged into the electrical outlet.

- Make sure the electrical plug is fully inserted into a live, properly grounded outlet.

A fuse in your home may be blown or the circuit breaker may have tripped.

- Replace the fuse or reset the circuit breaker.

### **The oven temperature is too hot or cold.**

The oven temperature needs to be adjusted and recalibrated.

- See page 29.

### **The oven burner will not shut off.**

The oven door lock is turned on.

- The display will show the Lock icon. Hold the oven door open and press  for 3 seconds. The oven will beep and the Lock icon will turn off.

The Sabbath function has been activated.

- SAb and the time of day will show in the display. All other controls and signals will be deactivated. To turn off the oven only, press OFF/CLEAR. To cancel the Sabbath function and reactivate the controls and signals, press and hold Bake and Number 1 simultaneously for seconds.

### **The oven light (lamp) will not turn on.**

The oven door lock is turned on.

- The display will show the Lock icon. Hold the oven door open, and then press  for seconds. The oven will beep and the Lock icon will turn off.

The Sabbath function has been activated.

- SAb and the time of day will show in the display. All other controls and signals will be deactivated. To cancel the Sabbath function and reactivate the light switch and other controls, press and hold Bake and Number 1 simultaneously for seconds.

A loose or burned-out bulb.

- See page 40.

The switch operating the oven light needs to be replaced.

- Call for a qualified service technician.

**The oven smokes excessively during broiling.**

Meat or food was not properly prepared before broiling.

- Cut away excess fat and/or fatty edges that may curl.

Improperly positioned top oven rack.

- See the broiling guide on page

The controls are not being set properly.

- See page 23.

Greasy buildup on oven surfaces.

- Regular cleaning is necessary when broiling frequently.

**Cooking is finished, but the cooling fan is still running.**

The fan automatically runs for a certain amount of time to ventilate the inside of the oven.

- This is not a product malfunction. The fan is designed to run automatically for a period of time to cool down the oven.

**The oven will not self-clean.**

The oven door lock is turned on.

- The display will show the Lock icon. Hold the oven door open, and then press  for seconds. The oven will beep and the Lock icon will turn off.

The oven is too hot.

- Let the oven cool down, and then reset the controls. The self-clean cycle will not lock the oven door if the oven temperature is too hot. The door must lock before the selfclean cycle can start.

The self-cleaning oven controls are not properly set.

- Reset the self-cleaning oven controls. (See page 38.)

A surface burner is on.

- Turn off the surface burner. Self-clean will not operate if a surface burner is on.

**A crackling or popping sound.**

This is normal.

- This is the sound of the metal heating and cooling during any cooking or cleaning function.

**Excessive smoking during a selfcleaning cycle.**

This is the first time the oven has been cleaned.

- This is normal. The oven will always smoke more the first time it is cleaned. Wipe up all excessive soil before starting the selfcleaning cycle. If smoke persists, press OFF/CLEAR. Open the windows to clear the smoke from the room. After the oven has cooled and unlocked, wipe up excessive soil, and then reset the oven for self-cleaning.

**The oven door will not open after a self-cleaning cycle.**

This is normal.

- The oven door will stay locked until the oven temperature drops below 400 °F.

**The oven is not clean after a selfcleaning cycle.**

A fine dust or ash is normal.

- This can be wiped clean with a damp cloth. Set the self-cleaning cycle for a longer cleaning time. The cycle was not long enough to burn off the dirt buildup. Extremely dirty ovens require hand-cleaning of excessive spillovers and food buildup before you start a self-cleaning cycle. Multiple self-cleaning cycles may be necessary to completely clean the oven

**There is steam or smoke coming from under the control panel.**

This is normal.

- The oven vent is located there. More steam is visible when you are using the convection functions or when baking or roasting multiple items at the same time.

**A burning or oily odor coming from the vent.**

This is normal for a new oven and will disappear within 1/2 hour of the first bake cycle.

- To speed the process, set a self-cleaning cycle for a minimum of 3 hours. (See page 38)

**Strong odor.**

This is temporary.

- The insulation around the inside of the oven emits an odor the first few times the oven is used.

**The oven racks are difficult to slide.**

This is normal.

- Apply a small amount of vegetable oil to a paper towel, and then wipe the edges of the oven racks with the paper towel. Racks become dull and hard to slide if they are left in the oven during a self-clean cycle.

**Fan noise.**



This is normal.

- The convection fan runs until the function is over or the door is opened.

**The convection fan is not working.**

This is normal.

- The fan starts automatically when the oven reaches the preheat temperature.

**Others**

**The product is not level.**

The appliance has been installed improperly.

The leveling leg(s) is (are) damaged or uneven.

- Make sure the floor is level, strong, and stable. If the floor sags or slopes, contact a carpenter.

Check and level the range. (See the Installation Instructions.)

The kitchen cabinets are not properly aligned and make the range appear to be not level.

- Ensure that cabinets are square and provide sufficient room for installation.

**The display goes blank.**

The electrical outlet Ground Fault Interrupter (GFI or GFCI) has been tripped and needs to be reset. Your digital control has been damaged.

- Replace the fuse or reset the circuit breaker.

**Food does not bake or roast properly in the oven.**

The wrong cooking mode was selected.

- See page 22.

The oven racks have not been positioned properly for the foods being cooked.

- See page 21.

Incorrect cookware or cookware of improper size is being used.

- See page 18.

The oven temperature needs to be adjusted and recalibrated.

- See page 29.

There is aluminum foil on racks and/or oven bottom.

- Remove foil.

The clock or timers are not set correctly.

- See pages 15

### **Food does not broil properly in the oven.**

The oven controls are not set properly.

- See page 23.

The oven door was not closed during broiling.

- See page 23.

The rack has not been properly positioned.

- See the broiling guide on page

### **Information codes**

**C-20** - Oven sensor malfunction.

**C-21** -The oven is overheating.

**C-22** - Check the Control PBA NTC Sensor.

**C-30** - Check the PBA NTC Sensor.

**C-31** - Control pad malfunction.

**C-d0** - Door lock malfunction.

**C-d1** - PCB signal malfunction.

**C- F0** - Touch IC and PCB signal malfunction.

**C-24** - Oven vent blocked.

1. If oven vent or cover air is blocked by aluminum foil or others, remove that and restart oven.
2. To reset error, disconnect power or tap OFF/CLEAR after opening the oven door at least 60 seconds.

#### **Warning**

This content is compiled from multiple sources and is provided for reference purposes only. It may not be complete or fully applicable to all situations. If you are unable to resolve your issue, please contact the product manufacturer or an authorized service provider for official support.