

## USER TIPS

Portable Air Conditioners are ideal for spot cooling. The compressor, condenser and evaporator are housed in a compact unit. The air is dehumidified and cooled while a flexible Hose sends heat outside. The air conditioner includes a window venting kit.

No permanent installation is needed. The unit is easy to move from room to room and offers a truly flexible air conditioning solution.

Auto Evaporation System - The unit automatically evaporates the condensate through the Hose. There is no need to empty the drainage tank except in very humid conditions. Read and follow the instructions carefully.

To ensure optimal efficiency of the product, keep doors and windows closed when it is used as an air conditioner or dehumidifier. If the product is being used with the fan function only, an open window could improve air circulation.

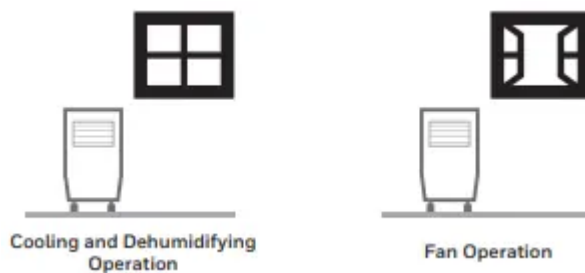

### Important:

Before installing the unit, place it UPRIGHT for 1 hour before use to allow the refrigerant to stabilize. Manually adjust the air vent located at the front of the unit to adjust the direction of air flow.

- Follow installation instructions to set up the unit.
- Plug the unit into a properly grounded circuit. DO NOT plug into an extension cord.

## PARTS DESCRIPTION

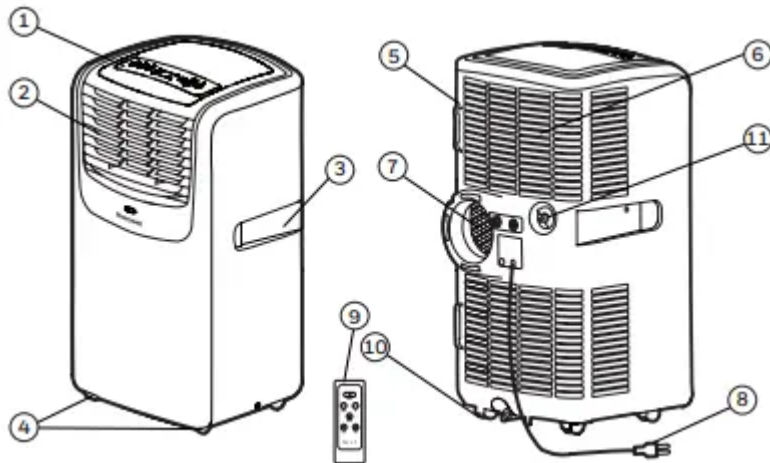

- 1) Control Panel (Incl. Signal Receptor)
- 2) Air Outlet
- 3) Handle
- 4) Casters
- 5) Dust Filter
- 6) Back Grill
- 7) Hose Connector
- 8) Power Supply Cord
- 9) Remote Control
- 10) Lower Rubber Drain Plug (Air Conditioning Mode)
- 11) Upper Rubber Drain Plug (Dehumidifier Mode)

## INSTALLATION

It is important that the installation instructions below are followed for successful installation of this Portable Air Conditioner. Please call Customer Support if you have any difficulties or queries regarding these installation procedures.

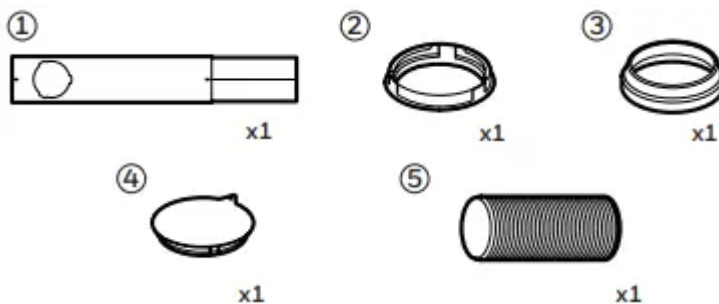

**Installation Kit:**

1. Window Bracket Kit	(1 Set)
2. Window Bracket Panel Adapter	(1 Piece)
3. Exhaust Hose Connector	(1 Piece)
4. Hole Cover	(1 Piece)
5. Exhaust Hose	(1 Piece)

**Installation Steps:**

1. Exhaust Hose Connector, Exhaust Hose and window bracket panel adapter are pre-assembled inside the package.

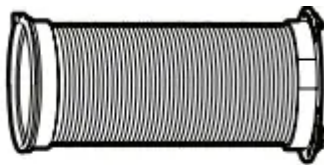

Exhaust Hose:  
Length: 12' to 47' (30 cm to 120 cm)

2. The Window Brackets are approximately 19.7" (50 cm) each, allowing you to install to windows and balcony doors of different heights or width.

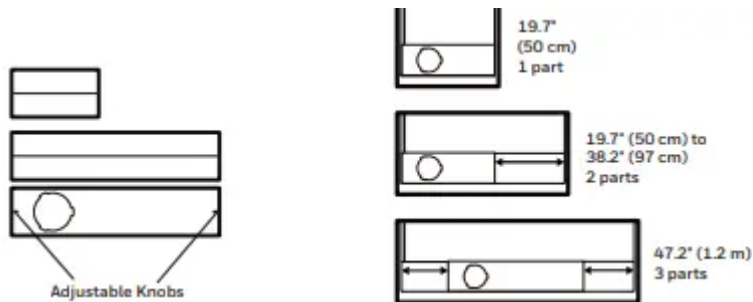

To install the window bracket to the window frame, you need to adjust the height or width of the window bracket by extending the length according to the height or width of the window. When the length is set, tighten the Adjustable Knobs (preinstalled on the window bracket) to ensure the window bracket is secured in the desired position. Use one or all two pieces of window bracket as needed.

**Note:** After setting the window bracket to the size of your window, please remove it from the window and follow the instructions below.

3. Connect the Exhaust Hose to the Exhaust Hose Connector on back of the unit. Slide-in the Exhaust Hose Connector. Press the  button to lock the Exhaust Hose Connector in place.



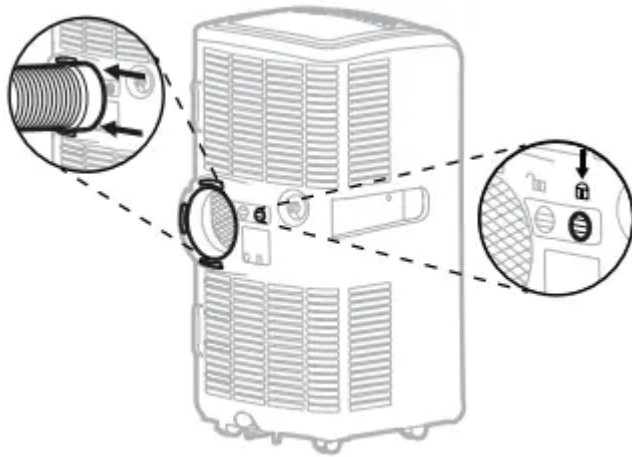

4. Connect the window bracket to the window bracket panel adapter. Slide-in the window bracket panel adapter then rotate clockwise until it is locked in place.

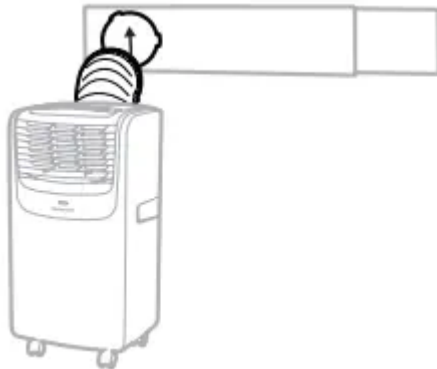

5. Connect the window bracket to the window.

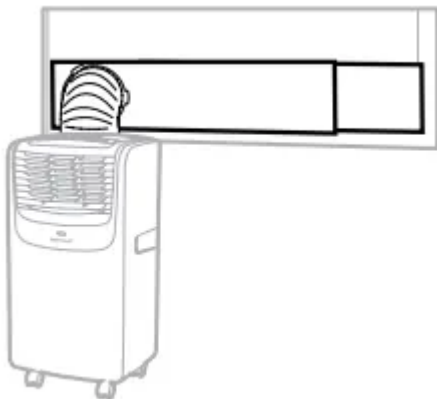

6. The Portable Air Conditioner is now ready to use.

**IMPORTANT:** Do not replace or lengthen the Exhaust Hose as this could cause the unit to malfunction.

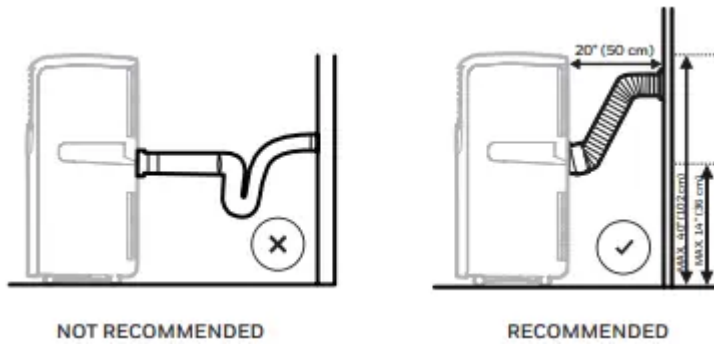

**WARNING:** Any warranties included with this product will be voided if an extra extension Hose is added to the originally provided installation kit or if the installation is performed differently than the manufacturer's instructions, without proper consultation. Please contact Customer Support for help with installation procedures if needed.

- The supplied Hose has a diameter of 5.5" (14 cm) and can be extended from 12" to 47" (30 cm to 120 cm).
- Do not bend (to the extent shown below) the Hose. A bent Hose will block exhaust air and cause the unit to malfunction or shut-off.
- Make sure the back of the unit is at least 20" (50 cm) away from the wall. Do not place the unit in front of curtains or drapes as this could obstruct the airflow.

## USE & OPERATION

### CONTROL PANEL

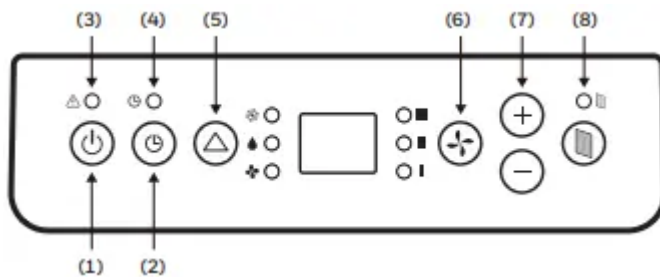

- 1) Power Control / Standby Mode
- 2) Timer Control
- 3) Warning Light (when flashing)
- 4) Timer Light
- 5) Mode Control
- 6) Fan Speed Control
- 7) Timer / Temperature Set Controls
- 8) Filter Alert

## FUNCTION BUTTONS

### POWER CONTROL

The Power Control turns the unit on and off. When the unit is plugged in, this button lights up indicating it is in a Standby Mode ready to be switched on anytime.

### TIMER CONTROL

While the unit is turned on, press the timer button then press the + or - to select the number of hours you would like the unit to continue to run. The unit will turn off automatically

### AUTO TURN OFF:

While unit is running, press  the button and the display will flash. While the display is flashing, press the + or - button to select the number of hours you want the unit to turn OFF automatically.

### AUTO TURN ON:

When unit is in a standby mode (plugged in with power light on), then press the + or - button to select the number of hours until you want the unit to automatically start running.

## TEMPERATURE / TIMER SET CONTROLS

- Used for adjusting the timer and thermostat.
- The default display is setting temperature.
- In cooling mode, when + or - button is pressed, the set temperature is displayed and may be adjusted. After 10 seconds the display will revert back to room temperature.  
Temperature is only adjustable in cool mode. The time is adjustable between 1 - 24 hours.

**Note:** By pressing both + or - buttons at the same time, the display will toggle between Celsius(°C) and Fahrenheit(°F).

### WARNING LIGHT

Condensation may accumulate in the unit.

If the internal tank becomes full, the Power Control light will flash and the unit will not operate until the unit has been drained (refer to Water Condensation Drainage).

After switching the air conditioner off, you must wait 3 minutes before switching it back on again.

### MODE CONTROL

Settings: Air Conditioning, Dehumidifying, Fan.

The corresponding indicator light will illuminate to indicate the current mode setting.

- Air Conditioning Mode 

Adjust fan speed and air temperature to suit your desired comfort level.

Temperature setting range is 16°C - 32°C (61°F - 89°F).

- Dehumidifying Mode 

Air is dehumidified as it passes through the unit, without being in full cooling mode.

If room temperature is higher than 25°C (77°F) fan speed can be adjusted; otherwise fan speed is preset to LOW.

Note: If the unit will be used mainly as a dehumidifier, do not connect the Hose.

Continuous drainage is then necessary (refer to Continuous Draining for Dehumidifier Mode).

- Fan Mode 

For air circulation without air conditioner cooling.

## FAN SPEED CONTROL

Applicable for model MO08 Series: High and Low.

Applicable for model MO10 Series: High, Medium and Low

## FILTER ALERT

When the Filter Alert Light is ON, it is time to clean the filter. Switch the air conditioner OFF and carefully remove the filter from the unit and clean. Replace the filter and switch ON the air conditioner.

The Filter Alert Light should not be illuminated until the filter requires cleaning again. The frequency of filter cleaning depends on room environment conditions. Some rooms may require changing more frequently than others.

## REMOTE CONTROL

The functions work the same as the Portable Air Conditioner's Control Panel.

All key functions can be accessed from the remote control.

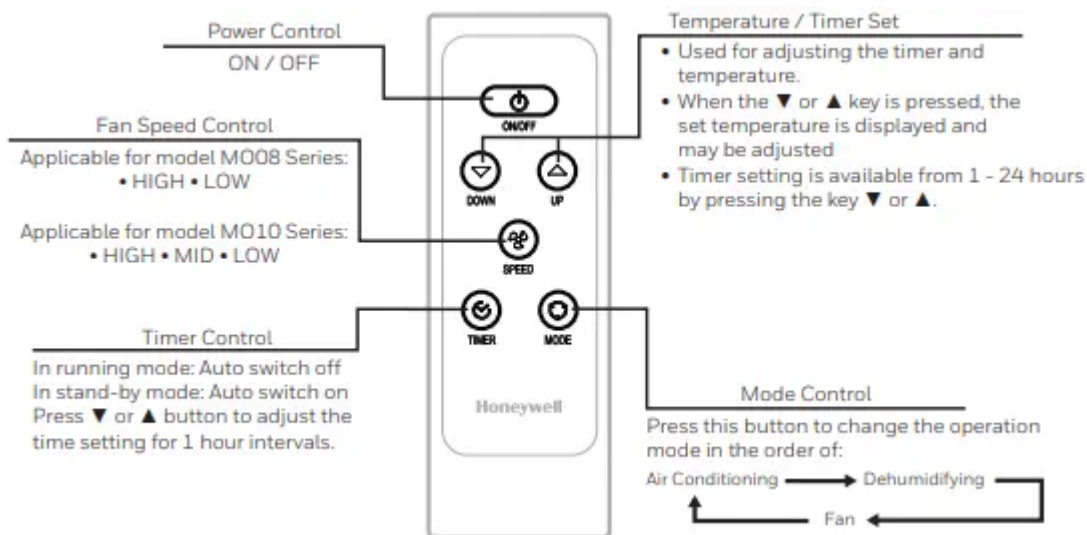

**Note:** Battery Installation: Remove the cover on the back of the remote control and insert two AAA batteries with + and - pointing in the proper direction according to the polarity markings.



**Caution:**

- Use only two AAA or IEC R03 1.5V batteries.
- Remove the batteries if the remote control is not in use for a month or longer.
- All batteries should be replaced at the same time, do not mix with old batteries.
- Do not mix alkaline, standard (carbon-zinc) or rechargeable (nickel-cadmium) batteries.
- Properly dispose of used batteries.

This device complies with part 15 of the FCC Rules. Operation is subject to following two conditions: (1) this device may not cause harmful interference, and (2) this device must accept any interference received, including interference that may cause undesired operation.

This equipment has been tested and found to comply with the limits for a Class B digital device, pursuant to part 15 of the FCC Rules. These limits are designed to provide reasonable protection against harmful interference in a residential installation. This equipment generates, uses and can radiate radio frequency energy and, if not installed and used in accordance with the instructions, may cause harmful interference to radio communications. However, there is no guarantee that interference will not occur in a particular installation. If this equipment dose cause harmful interference to radio or television reception, which can be determined by turning the equipment off and on, the user is encouraged to try to correct the interference by one or more of the following measures:

Reorient or relocate the receiving antenna.

Increase the separation between the equipment and the receiver.



Connect the equipment into an outlet on a circuit different from that to which the receiver is connected.

Consult the dealer or an experienced radio/ TV technician for help.

**Caution:** Any changes or modifications not expressly approved by the party responsible for compliance could void the user's authority to operate the equipment.

## CLEANING & MAINTENANCE

### Appliance Maintenance:

1. Turn off the appliance before disconnecting the power supply.
2. Only clean the appliance with a soft dry cloth.

### Dust Filter Maintenance:

The dust filter is to be cleaned every two weeks to maintain air cooling efficiency. Please follow the below instructions for cleaning the dust filters:

1. Turn off the appliance and remove the upper and lower dust filters.
2. Rinse it in lukewarm water. After cleaning, dry in a shaded and cool place, then reinstall.

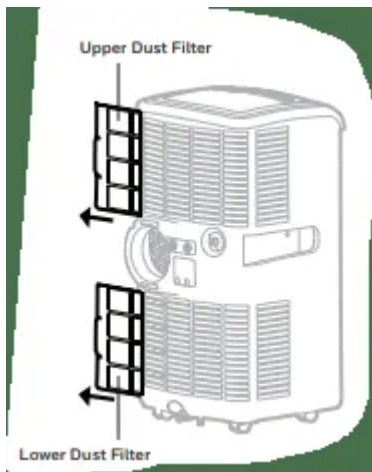

### End of Season Storage & Maintenance:

If the appliance will not be used for a long time, follow these steps:

1. Be sure to drain the left-over water condensation. Remove the lower drain plug and use a shallow pan to collect the water (make sure to replace the drain plug when finished).
2. To dry excess moisture, run the unit in Fan only mode for 30 minutes before storing.
3. Turn off and unplug the air conditioner from the power supply.
4. Remove the dust filter and clean with water. Dry the dust filter and then reinstall.

## 5. Disconnecting the Window Installation Kit:

- Remove the Hose from the unit by rotating anti-clockwise to unlock the knob mechanism then sliding out.
- Remove the window bracket panel adapter from the window bracket by rotating anti-clockwise then pulling away.
- It is recommended to store the Window Kit parts in a bag together with the Remote Control and placing them together with the air conditioner unit.
- If needed, you can clean the Window Kit with a damp cloth and water before storing. Make sure all parts of the Window Kit are dry before storage.

6. Cover the air conditioner with a cloth/plastic bag before storage, to protect from dust and scratches collecting on the surface of the unit.

7. It is recommended to coil the power cord before storing to ensure the cord is protected from bents and creases.

8. Store the air conditioner in a cool, dry place, away from direct sunlight.

## WATER CONDENSATION DRAINAGE

When there is excess water condensation inside the unit, the air conditioner stops running and shows a warning light (the Power Control button flashes with a red light). This warning light indicates that the water condensation needs to be drained using the following procedures:

### Manual Draining for AC & Dehumidifier Mode

Water may need to be drained in high humidity areas.

1. Unplug the unit from power source.
2. Place a shallow pan under the lower rubber drain plug. See diagram.
3. Remove the lower rubber drain plug.
4. Water will drain out and collect in the shallow pan.
5. After the water is drained, replace the lower rubber drain plug firmly.
6. You can now turn on the unit.

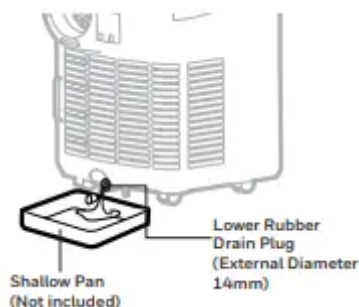

### Continuous Draining for Dehumidifier Mode

While using the unit in dehumidifier mode, continuous drainage is recommended.

1. Unplug the unit from power source.
2. Remove the upper/lower rubber drain plug. Some residual water may spill so please have a pan to collect the water. See diagram.
3. Connect the drain connector to a  $\frac{3}{4}$ " Hose or standard garden Hose (not included).
4. The water can be continuously drained through the drain tube into a floor drain or bucket.
5. Replace the drain plug.
6. You can now turn on the unit.

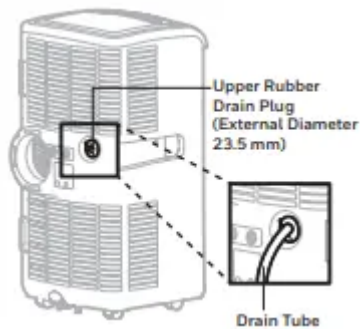

## TROUBLESHOOTING GUIDE

The following troubleshooting guide addresses the most common problems. If problems persist, call customer support. Unplug and disconnect the appliance from the power source before attempting to troubleshoot.

<b>PROBLEM</b>	<b>POSSIBLE CAUSE</b>	<b>SOLUTION</b>
The air conditioning unit does not start	No electricity.	Check for power.
	Batteries in the remote control need to be replaced.	Change remote control batteries
	The power cord is not properly plugged in.	Remove and reconnect the power cord.
	The safety LCDI plug has tripped (USA / Canada / Mexico only).	Reset the safety LCDI plug, if problem persists contact our customer support (USA / Canada / Mexico only).
Runs a short while only	The thermostat temperature setting is too close to room temperature.	Lower the set temperature.
	Air outlet is blocked.	Make sure the Hose is properly connected.
	There are tight bends in the air Hose.	Connect Hose as per instructions on page 3.
Runs but not cooling	A door or window is open.	Make sure the window or door is closed.
	The dust filter is dirty.	Clean the dust filter
	The Hose is detached.	Reinstall Hose properly (refer to Installation section).
	Temperature setting is too high.	Reduce temperature setting on control panel.
	Air outlet or intake is blocked.	Remove blockage.
	Room exceeds recommended size.	Move unit to smaller room.
	Large size or number of windows are decreasing cooling effectiveness.	Cover windows with curtains or blinds.

Will not run and Power button is blinking (water full indicator)	Excess water condensation inside the tank.	Drain the water (refer to Water Condensation Drainage).
--	--	---

## ERROR CODE GUIDE

ERROR CODE	ERROR POSSIBLE CAUSE
"E1"	Temperature sensor open circuit/short circuit.
"E2" (for cooling and heating model)	Copper tube sensor open circuit/ short circuit.
"Lo"	Temperature is below -9°C (32°F).
"Hi"	Temperature is over 50°C (99°F).

### Warning

This content is compiled from multiple sources and is provided for reference purposes only. It may not be complete or fully applicable to all situations. If you are unable to resolve your issue, please contact the product manufacturer or an authorized service provider for official support.