

What's in the Box



Camera



Waterproof Lid



1m Ethernet Cable

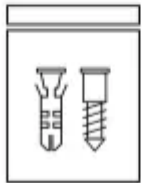

Pack of Screws



Power Adapter



Quick Start Guide



Surveillance Sign

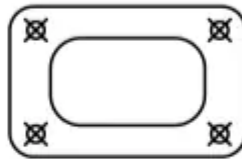

Mounting
Hole Template

Camera Introduction

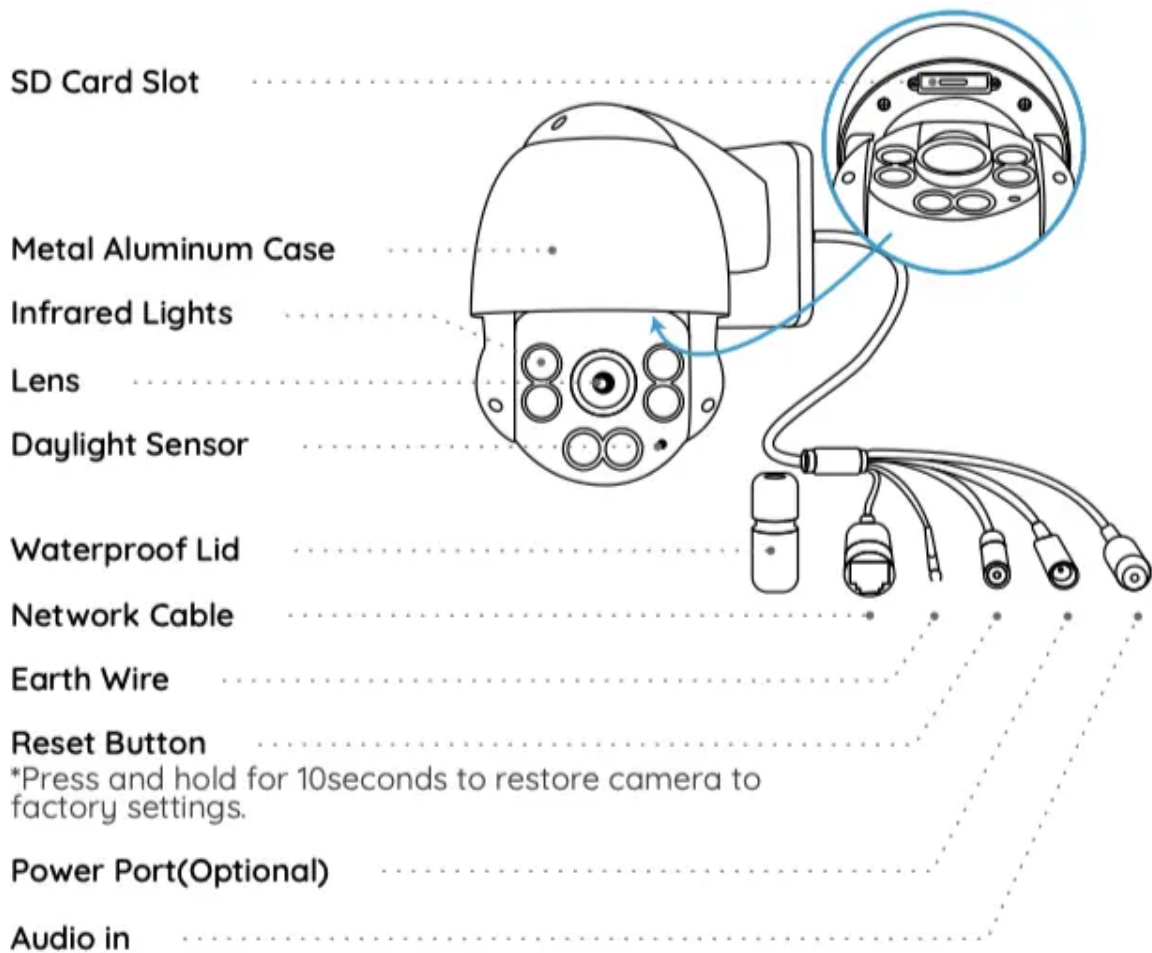

Camera Connection Diagram

Before using the camera, please connect your camera as instructed below to finish initial setup.

1. Connect the camera to a LAN port on your router with an Ethernet cable.
2. Power on the camera with a power adapter.

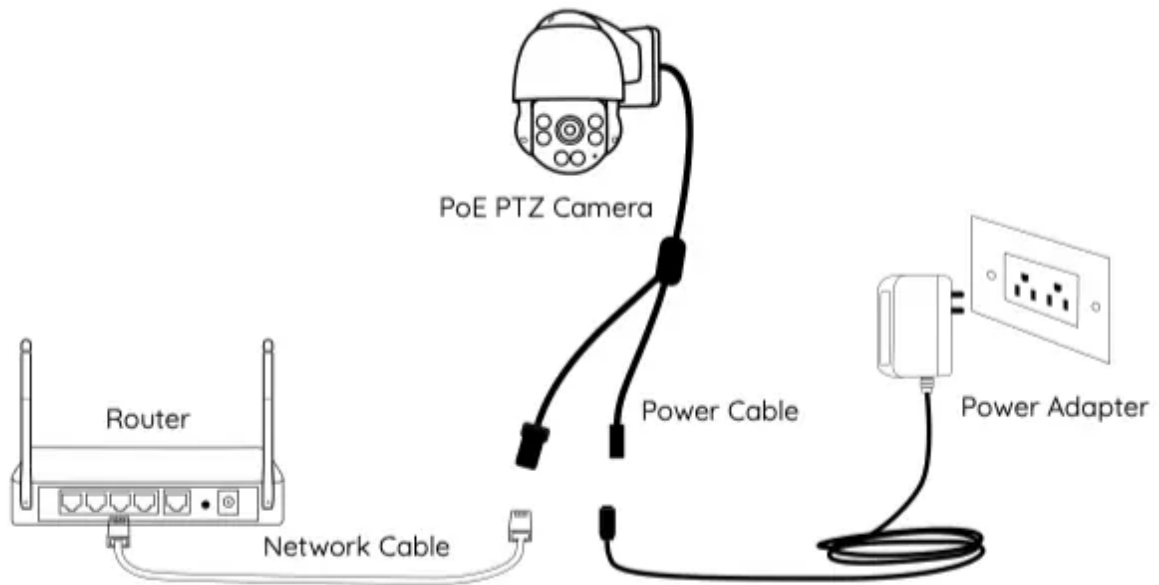

*You may also connect the camera to a PoE Switch/Injector or Reolink PoE NVR.

Set up the Camera

Download and launch the Reolink App or Client software and follow the onscreen instructions to finish initial setup.

• On Smartphone

Scan to download the Reolink App.

• On PC

Download path of the Reolink Client: Go to reolink > Support > App & Client.

NOTE: If you are connecting the camera to a Reolink PoE NVR, please set up the camera via the NVR interface.

Mount the Camera

Installation Tips

- Do not face the camera towards any light sources.
- Do not point the camera towards a glass window. Or, it may result in poor image performance because of the window glare by infrared LEDs, ambient lights or status lights.
- Do not place the camera in a shaded area and point it towards a well-lit area. Or, it may result in poor image performance. For better image quality, please make sure that the lighting condition for both the camera and the capture object is the same.

- For better image quality, it's recommended to clean the lens with a soft cloth from time to time.
- Make sure the power ports are not exposed to water or moisture or blocked by dirt or other elements.
- The camera comes with waterproof design so it can work properly under conditions like rain and snow. However, it doesn't mean the camera can work underwater.
- Do not install the camera at places where rain and snow may hit the lens directly.
- The camera may work in extreme cold conditions as low as -25°C. Because when it is powered on, the camera will produce heat. You may power on the camera indoors for a few minutes before installing it outdoors.

Mount the Camera to the Wall

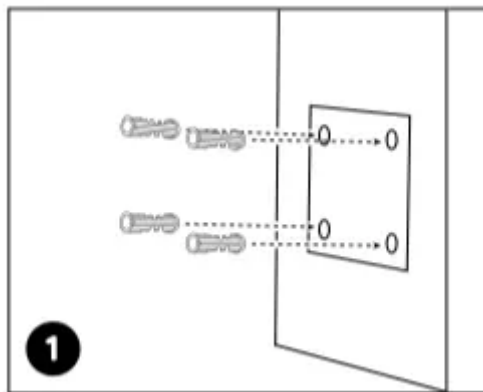

Drill holes in accordance with the mounting hole template.

NOTE: Use the drywall anchors included in the package if needed.

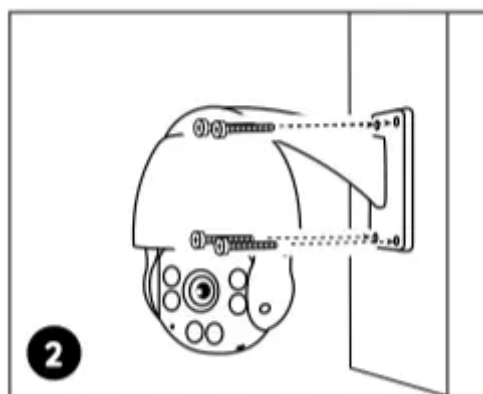

Install the mount base with screws included in the package.

NOTE: Run the cable through the cable notch on the mount base.

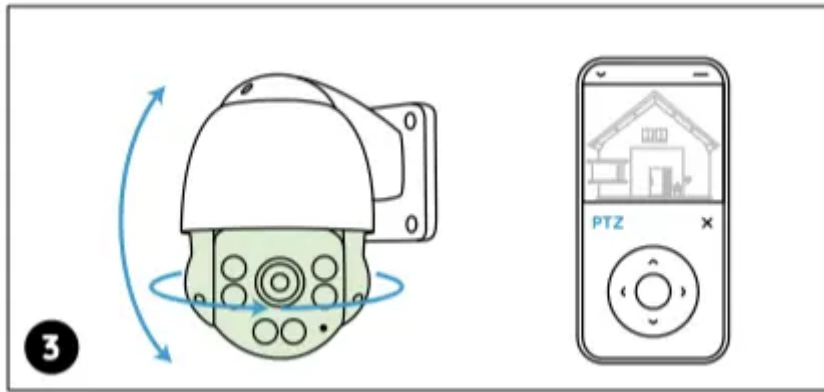

To adjust the camera direction, you may control the camera to pan and tilt via Reolink app or Client.

Troubleshooting

Camera Is Not Powering on

If your camera is not powering on, please try the following solutions:

- Make sure your camera is powered on properly. The PoE camera should be powered by a PoE switch/injector, a Reolink NVR or a 12V power adapter.
- If the camera is connected to a PoE device as listed above, connect the camera to another PoE port and see if the camera will power on.
- Try again with another Ethernet cable.

If these won't work, contact Reolink Support support.reolink.

Infrared LEDs Stop Working

If the Infrared LEDs on your camera stop working, please try the following solutions:

- Enable infrared lights on Device Settings page via Reolink App/Client.
- Check if the Day/Night mode is enabled and set up auto infrared lights at night on Live View page via Reolink App/Client.
- Upgrade the firmware of your camera to the latest version.
- Restore the camera to factory settings and check out the infrared light settings again.

Failed to Upgrade the Firmware

If you cannot upgrade firmware for the camera, try the following solutions:

- Check out the current camera firmware and see if it is the latest one.
- Make sure that you download the correct firmware from Download Center.

- Make sure that your PC is working on a stable network.

Specifications

Hardware Features

Night Vision: 60 meters (190ft)

Day/Night Mode: Auto switchover

Angle of View : Horizontal : 87°- 31°, vertical : 65° - 24°

General

Operating Temperature: -10°C to 55°C (14°F to 131°F)

Operating Humidity: 10%-90%

Ingress Protection: IP66

Size: Φ 1 36 x 201mm

Weight: 1.70kg

Notification of Compliance

FCC Compliance Statement

This device complies with Part 15 of FCC Rules. Operation is subject to the following two conditions: (1) this device may not cause harmful interference, and (2) this device must accept any interference received, including interference that may cause undesired operation.

NOTE: This equipment has been tested and found to comply with the limits for a Class B digital device, pursuant to Part 15 of the FCC Rules. These limits are designed to provide reasonable protection against harmful interference in a residential installation.

Simplified EU Declaration of Conformity

Reolink declares that this device is in compliance with the essential requirements and other relevant provisions of Directive 2014/53/EU.

Correct Disposal of This Product

This marking indicates that this product should not be disposed with other household wastes throughout the EU. To prevent possible harm to the environment or human health from uncontrolled waste disposal, recycle it responsibly to promote the sustainable reuse of material resources. To return your used device, please use the return and collection systems or contact the retailer where the product was purchased. They can take this product for environmentally safe recycling.

Limited Warranty

This product comes with a 2-year limited warranty that is valid only if purchased from Reolink official stores or a Reolink authorized reseller.

NOTE: We hope that you enjoy the new purchase. But if you are not satisfied with the product and plan to return, we strongly suggest that you reset the camera to factory default settings and take out the inserted SD card before returning.

Terms and Privacy

Use of the product is subject to your agreement to the Terms of Service and Privacy Policy at reolink. Keep out of reach of children.

End User License Agreement

By using the Product Software that is embedded on the Reolink product, you agree to the terms of this End User License Agreement (“EULA”) between you and Reolink.

Warning

This content is compiled from multiple sources and is provided for reference purposes only. It may not be complete or fully applicable to all situations. If you are unable to resolve your issue, please contact the product manufacturer or an authorized service provider for official support.