

## Setting up your microwave oven

### FEATURES

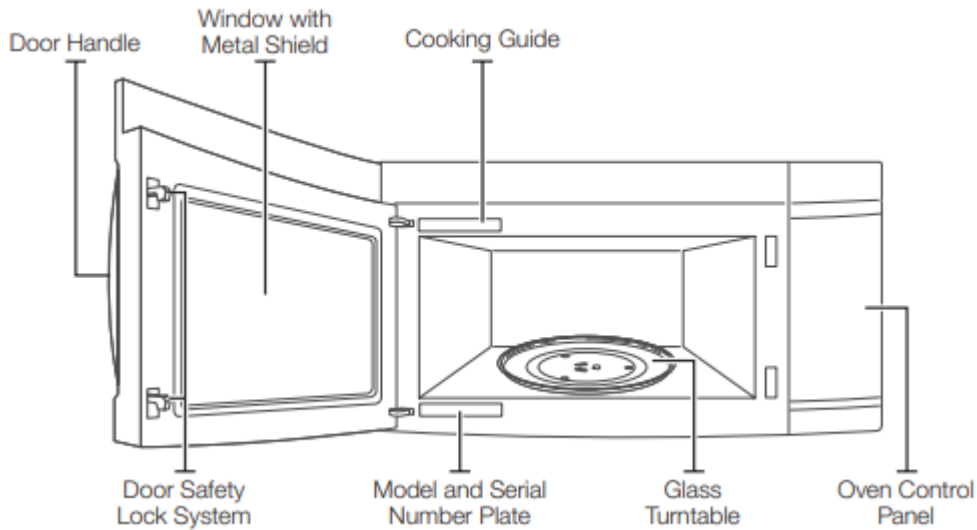

### CHECKING THE CONTROL PANEL

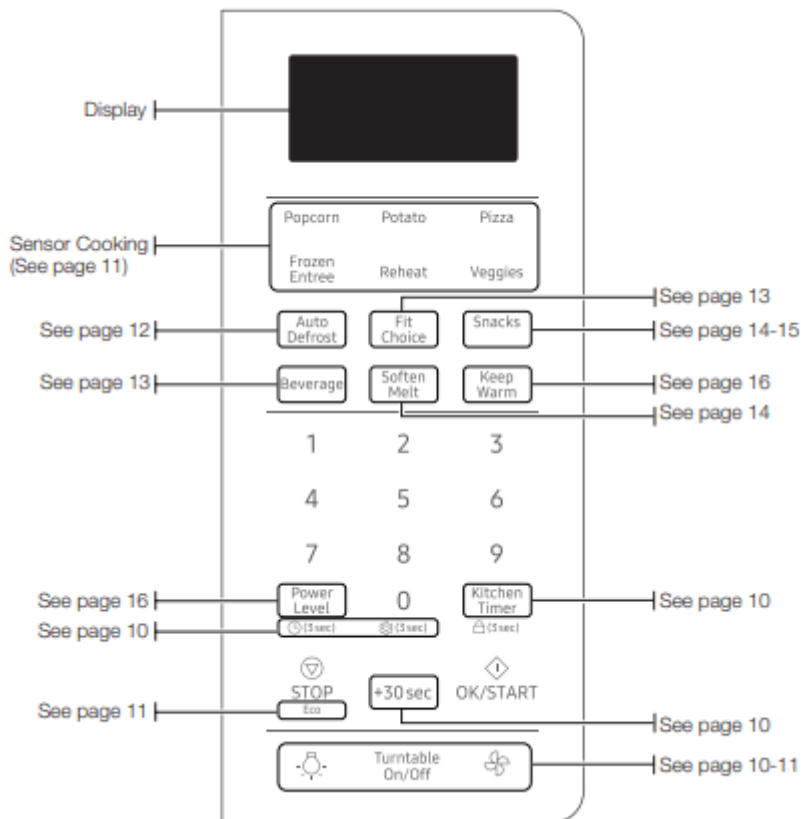

## SETTING THE TIME

Your microwave oven is equipped with a built-in clock. Set the clock when first installing your microwave oven and after a power failure. The time is displayed whenever the microwave oven is not being used.

1. Press the Power Level button for 3 seconds.
2. Use the number buttons to enter the current time. You need to press at least three numbers to set the clock. For example, if the current time is 5:00, press 5, 0, 0. The display will show: 500.
3. Press the Power Level button.
4. Use the Power Level button to select AM / PM.
5. Press the OK/START button.
6. A colon appears indicating that the time is set.

## CHILD LOCK

The Child Lock function allows you to lock the buttons so that the microwave oven cannot be operated accidentally. The oven can be locked at any time.

### Activating/Deactivating

If you want to activate or deactivate the child lock function, press the Kitchen Timer button for 3 seconds.

The display will show ON when the oven is locked, and then re-displays the time.

## Using your microwave oven

Cooking has never been easier than with your new Samsung microwave oven.

The following section describes everything you need to know about using your microwave oven.

## KITCHEN TIMER BUTTON

Use the Kitchen Timer for timing up to 99 minutes, 99 seconds.

1. Press the Kitchen Timer button.
2. Use the number buttons to set the length of time you want the timer to run.
3. Press the OK/START button.
4. The display counts down and beeps when the time has elapsed.
5. To cancel the timer setting: Press the STOP button once.

## ADD 30 SEC BUTTON

This simplified control saves you time, letting you quickly start cooking at 100 % power.

1. Press the Add 30 sec button for each 30 seconds you want food to cook. For example, press it twice to cook for one minute, and then press the OK/ START button to start cooking.
2. Add 30 sec to a cooking program already in progress by pressing the Add 30 sec button for every additional 30 seconds you want to add.

## VENT BUTTON ()

The vent removes steam and other vapors from the cooking surface. You can manually select the vent setting.

Press (times)	1	2	3	4	5
Speed	4	3	2	1	Off



The exhaust fan's speed will decrease when the oven's cooking function is activated.

## LIGHT HI/LO/OFF BUTTON ()

The Light button allows you to select a light setting for your microwave.

Press (times)	1	2	3
Light	High	Low	Off

## TURNTABLE ON/OFF BUTTON

For best cooking results, leave the turntable on. However, for large dishes it can be turned off.

Press the Turntable On/Off button to turn the turntable on or off.



The turntable may become too hot to touch. Use pot holders to touch the turntable during and after cooking.

## ECO MODE

Eco Mode reduces standby power usage.

To start ECO Mode, press the STOP button once. The display will go out and the microwave shifts to the Eco mode which minimizes power usage.

To cancel the Eco Mode, press the STOP button once again, or press any other button.

## REHEAT BUTTON

Heating leftovers and precooked foods is easy with your new microwave. By actually sensing the humidity that escapes as the food is heated, the oven's heating time is automatically adjusted depending on the type and amount of precooked food.



All food must already be precooked. Plates of food and casseroles should be stored at refrigerator temperature. Press the Reheat button and OK/START button to begin reheating your precooked food.

### Reheating table

Follow the instructions below when reheating different types of food.

Food	Amount	Procedure
Dinner plate (rh-2)	1 serving (1 plate)	Use only precooked, refrigerated foods. Cover the plate with vented plastic wrap or waxed paper tucked under the plate. If the food is not as hot as you would like after using the Sensor Reheat function, continue heating using additional time and power. <b>Contents:</b> 3-4 oz. meat, poultry, or fish (up to to 6 oz. with bone) ½ cup starch (potatoes, pasta, rice, etc.) ½ cup vegetables (about 3 - 4 oz.)
Casserole (rh-1)	1 to 4 servings	Cover the plate with a lid or vented plastic wrap. If the food is not as hot as you would like after using the "Sensor Reheat" function, continue heating using additional time and power. Stir the food once before serving. <b>Contents:</b> Casserole, refrigerated foods.
Pasta (rh-3)		Pasta: canned spaghetti and ravioli

## AUTO DEFROST BUTTON

To thaw frozen foods, enter the weight of the food, and the microwave automatically sets the defrosting time, power level, and standing time. Press the OK/START button to start defrosting.

1. Press the Auto Defrost button.
2. Press the number buttons to directly enter the weight of the food.
3. Press the OK/START button.
4. The oven will beep twice during the defrosting process. Open the oven door, and turn the food over.

### Auto defrosting table

Follow the instructions below when defrosting different types of food.

Food	Amount	Procedure
Roast Beef, Pork	2.5-6.0 lbs.	Start with the food placed fat side down. After each stage, turn the food over and shield any warm portions with narrow strips of aluminum foil. Let stand, covered for 10-20 minutes.
Steaks, Chops, Fish	0.5-3.0 lbs.	After each stage, rearrange the food. If there are any warm or thawed portions of food, shield them with narrow, flat pieces of aluminum foil. Remove any pieces of food that are nearly defrosted. Let stand, covered for 5-10 minutes.
Ground Meat	0.5-3.0 lbs.	After each stage, remove any pieces of food that are nearly defrosted. Let stand, covered with foil for 5-10 minutes.
Whole Chicken	2.5-6.0 lbs.	Remove giblets before freezing poultry. Start defrosting with the breast side down. After the first stage, turn the chicken over and shield any warm portions with narrow strips of aluminum foil. After the second stage, again shield any warm portions with narrow strips of aluminum foil. Let stand, covered for 30-60 minutes in the refrigerator.
Chicken Pieces	0.5-3.0 lbs.	After each stage, rearrange or remove any pieces of food that are nearly defrosted. Let stand for 10-20 minutes.



Check the food when you hear the oven signal. After the final stage, small sections may still be icy. Let the food stand to continue the thawing process. The food is not defrosted until all ice crystals have thawed. Shielding the edges of roasts and pieces of steak using small pieces of foil prevents the edges from being cooked before the center of the food has defrosted. Use narrow, flat, smooth strips of aluminum foil to cover edges and thinner sections of the food.

## 1 POUND DEFROST FUNCTION

To thaw 1 pound of frozen food, use the 1 Pound Defrost Function. The microwave will automatically set the defrosting time, power level and standing time.

1. Press the Auto Defrost button twice. The display shows: 1.0 LB.
2. Press the OK/START button to start defrosting.
3. The oven will beep and the display will read TURN THE FOOD OVER twice during the defrosting process. Open the oven door, and turn the food over.
4. If you do not turn the food over when TURN THE FOOD OVER is displayed, the oven will pause until you press the OK/ START button.

## FIT CHOICE BUTTON

1. Press the Fit Choice button. Press the button repeatedly to cycle through the available items. (Refer to the Fit Choice table below for a list of the items.)
2. Press the 1, 2, 3, or 4 button to select the amount.
3. Press the OK/START button to begin cooking.

### Fit Choice table

Menu / Item		No. / Amount		Remarks
FC-1	Spinach	1	1 Serving	Wash and clean the spinach. Place the spinach in a microwave safe bowl. Add 1-4 tablespoons of water (1 Tbsp per serving). Cover during cooking and stir afterwards.
		2	2 Servings	
		3	3 Servings	
		4	4 Servings	
FC-2	Squash	1	1-2 lbs.	Slice the squash in half and remove the seeds. Place the squash cut side down in a microwave safe dish and cover with the plastic wrap. If needed, add a ¼ cup of water.
		2	2-3 lbs.	
FC-3	Brown rice	1	1 Serving : 0.5 cup	Place 0.5 cup brown rice + 1 cup water for 1 serving or 1 cup brown rice + 2 cups water for 2 servings in a microwave safe bowl. Stir well before and fluff with a fork afterwards. Let stand 5 minutes before serving.
		2	2 Servings : 1 cup	
FC-4	Oatmeal	1	1 Package	Follow the package directions for the recommended amount of water needed. Stir well before and afterwards.
		2	2 Packages	
FC-5	Quinoa	1	1 Serving : 1 cup	Follow the package directions for the recommended amount of water needed. When the microwave beeps, stir well, and then restart the microwave.
		2	2 Servings : 2 cups	
FC-6	Bone in chicken pieces	1	2 Servings : 1.0 lb.	Brush the chicken pieces with oil and seasonings. Arrange chicken pieces in dish with meatiest portions toward the outside edge of dish, and then cover with wax paper. Place the dish on the center of the turntable.
		2	4 Servings : 2.0 lbs.	
FC-7	Fresh fish fillet	1	1 Serving : 1 ea	Put the fillets (cod, pollack, etc.) in a dish, and then cover with plastic wrap. Place the dish on the center of the turntable.
		2	2 Servings : 2 ea	
FC-8	Fresh salmon fillet	1	1 Serving : 1 ea	Put the salmon fillets in a dish, and then cover with plastic wrap. Place the dish on the center of the turntable.
		2	2 Servings : 2 ea	
FC-9	Fresh prawns	1	2 Servings : 0.5 lb.	Put the prawns in a dish, and then cover with plastic wrap. Place the dish on the center of the turntable.
		2	4 Servings : 1.0 lb.	

## BEVERAGE BUTTON

1. Press the Beverage button.
2. Press the 1, 2, or 3 button to select the Amount.
3. Press the OK/START button.

Food	No. / Amount	Procedure
Beverage	1	0.5 cup
	2	1 cup
	3	2 cups
		Use a measuring cup or mug and do not cover. Place the beverage in the oven. After heating, stir well. Let the oven cool for at least 5 minutes before using it again.

## SOFTEN/MELT BUTTON

1. Press the Soften/Melt button. Press the button repeatedly to cycle through the available items. (Refer to the Soften/Melt table below for a list of the items.)
2. Press the number 1 or 2 button to select the amount. You can cook only 1 serving for the Melt Chocolate, Soften Butter, and Soften Cream Cheese options. (Refer to the Soften/Melt table for the serving size.)
3. Press the OK/START button to begin cooking.



### Soften / Melt table

Menu / Item		No. / Amount		Remarks
<b>St-1</b>	Melt butter	<b>1</b>	1 stick	Remove the wrapping and cut the butter in half vertically. Place the butter in a dish and cover with wax paper. Stir well after finishing and let stand for 1-2 minutes.
		<b>2</b>	2 sticks	
<b>St-2</b>	Melt chocolate	<b>1</b>	1 cup chips or 1 square	Place the chocolate chips or squares in a microwave-safe container. When the oven beeps, stir the chocolate and restart the oven. Stir and let stand for 1 minute.
<b>St-3</b>	Soften butter	<b>1</b>	1 stick (¼ lbs.)	Remove wrapping and cut butter in half vertically. Place butter in dish, cover with wax paper.
<b>St-4</b>	Soften cream cheese	<b>1</b>	1 Package (8-oz)	Unwrap the cream cheese and place on a microwave-safe container. Cut in half vertically. Let stand for 2 minutes.

## SNACKS BUTTON

1. Press the Snacks button. Press the button repeatedly to cycle through the available items. (Refer to the Snack bar table below for a list of the items.)
2. Press the number 1 or 2 button to select the serving size. You can cook only 1 serving for Nachos. (Refer to the Snack bar table for the serving size.)
3. Press the OK/START button to begin cooking.

### Snack bar table

Menu / Item		No. / Amount		Remarks
<b>Sn-1</b>	Frozen Chicken Nugget	<b>1</b>	1 serving (3 oz)	Place a paper towel on a plate and arrange the nuggets in a spoke-like fashion on the paper towel. Do not cover. Let stand for 1 minute after heating.
		<b>2</b>	2 servings (6 oz)	 Refer to the package directions for the serving size and the amount of food.
<b>Sn-2</b>	Frozen French Fries	<b>1</b>	1 serving (3 oz)	Place two paper towels on a microwave-safe plate and arrange the French fries on the towels without letting them overlap. Blot the fries with additional paper towels after removing from the oven. Let stand for 1 minute.
		<b>2</b>	2 servings (6 oz)	 Refer to the directions on the packaging for the serving size and the amount of food.
<b>Sn-3</b>	Frozen Sandwiches (in crisping sleeve) 9-oz package size	<b>1</b>	1 sandwich	Place the frozen sandwich in a susceptor "crisping sleeve" (which is in the package) and place on a microwave-safe plate. Remove from the "crisping sleeve". Let stand for 2 minutes after heating.
		<b>2</b>	2 sandwiches	
<b>Sn-4</b>	Hot dogs	<b>1</b>	2 hot dogs	Pierce the hot dogs and place them on a plate. When the oven beeps, add the buns and restart the oven. Let stand for 1 minute after heating.
		<b>2</b>	4 hot dogs	 For the best texture, the buns should be added to the hot dogs when the oven beeps.

Menu / Item		No. / Amount	Remarks
Sn-5	Frozen Cheese sticks	1	1 serving (5-6 pcs)
		2	2 servings (7-8 pcs)
Sn-6	Chicken wings (refrigerated)	1	1 serving (5-6 oz)
		2	2 servings (7-8 oz)
Sn-7	Nachos	1	1 serving (8-10 ea) <b>Contents:</b> 8-10 ea tortilla chips ¼ cup grated cheese
Sn-8	Potato skins	1	1 cooked potato
		2	2 cooked potato

## MICROWAVE COOKING TIMES & POWER LEVELS

Your oven allows you to set two different cooking stages, each with its own time length and power level. The power level lets you control the heating intensity from Warm (1) to High (10).

### One-stage cooking

For simple, one-stage cooking with the power level set to High (10), you only need to set the cooking time, and then press OK/START. The power level is automatically set to High. If you want to set the power level to any other level, use the Power Level button.

1. Use the number buttons to set a cooking time. You can enter a time from one second to 99 minutes and 99 seconds. To select a time greater than one minute, enter the seconds too. (For example, to set a cooking time of 20 minutes, enter 2, 0, 0, 0.)
2. If you want to set the power level to a level other than High, press the Power Level button, and then use the number buttons to enter the power level.
3. Press the OK/START button to begin cooking. If you want to change the power level, press the STOP button before you press the OK/START button, and then follow the instructions from Step 1 again.



Some recipes require different cooking stages at different temperatures. Your microwave allows you to set multiple cooking stages.

### Multi-stage cooking

1. Follow steps 1 and 2 from the “One-stage cooking” section.
2. Use the number buttons to set a second cooking time.
3. Press the Power Level button, and then use the number buttons to set the power level for the second cooking stage.
4. Press the OK/START button to begin cooking.

 When selecting more than one cooking stage, you must press the Power Level button before you can enter the second cooking stage time and power level.

 Press the Power Level button twice to set the power level to High for a cooking stage.

### Power Levels

The 10 power levels allow you to choose the optimal power level for your cooking needs.

1	Warm	6	Simmer
2	Low	7	Medium high
3	Defrost	8	Reheat
4	Medium low	9	Sauté
5	Medium	10	High

### KEEP WARM

You can keep cooked food warm in your microwave oven for up to 99 minutes 99 seconds.

1. Press the Keep Warm button.
2. Enter the warming time.
3. Press the OK/START button.

 Keep Warm operates for up to 99 minutes 99 seconds.

 Food that is cooked covered should also be covered during Keep Warm.

 Pastry items (pies, turnovers, etc.) should be uncovered during Keep Warm.

 Complete meals kept warm on a dinner plate can be covered during Keep Warm.

Below are the amounts of food we recommend you apply the Warm and Hold function to by Food Type.

Food type	Recommended Quantity
Liquid	1-2 cups
Dry	5-10 oz.

### Cleaning and maintaining your microwave oven

Keeping your microwave oven clean improves its performance, wards off unnecessary repairs, and lengthens its life.

## CLEANING THE EXTERIOR

It's best to clean spills on the outside of your microwave oven as they occur. Use a soft cloth and warm, soapy water. Rinse and dry.



Do not get water into the vents. Never use abrasive products or chemical solvents such as ammonia or alcohol as they can damage the appearance of your microwave.

### Cleaning under your microwave oven

Regularly clean grease and dust from the bottom of your microwave using a solution of warm water and detergent.

### Cleaning the control panel

Wipe with a damp cloth and dry thoroughly. Do not use cleaning sprays, large amounts of soap and water, abrasives, or sharp objects on the panel as it is easily damaged.

### Cleaning the door and door seals

Always ensure that the door seals are clean and that the door closes properly. Take particular care when cleaning the door seals to ensure that no particles accumulate and prevent the door from closing correctly. Wash the glass door with very mild soap and water. Be sure to use a soft cloth to avoid scratching.

If a thin film of water accumulates on the inside or outside of the oven door, wipe it off with a soft cloth. A thin water film can accumulate when you operate the oven when humidity is high and in no way indicates microwave leakage.

## CLEANING THE INTERIOR



Ensure that the microwave oven has cooled down before cleaning it to avoid injury.



Remove the glass tray from the oven when cleaning the oven or tray. To prevent the tray from breaking, handle it with care and do not put it in water immediately after cooking. Wash the tray carefully in warm sudsy water or in the dishwasher.

Clean the interior surfaces (oven cavity) of your microwave oven periodically to remove any splashes or stains. To remove hardened food articles and remove smells, place 2 cups of water (add lemon juice for extra freshness) into a four-cup measuring glass. Run the microwave at High power for 5 minutes or until the water boils. Let the water stand in the oven for one or two minutes.

## CLEANING THE TURNTABLE AND ROLLER RINGS

Clean the roller rings periodically and wash the turntable as required. You can wash the turntable safely in your dishwasher.

## STORING AND REPAIRING YOUR MICROWAVE OVEN

If you need to store your microwave oven for a short or extended period of time, choose a dust-free, dry location. Dust and dampness may adversely affect the ability of the microwave parts.



- Do not repair, replace, or service any part of your microwave oven yourself. Allow only a qualified service technician to perform repairs. If the oven is faulty and needs servicing, or you are in doubt about its condition, unplug the oven from the power outlet and contact your nearest Samsung service center.
- Do not use the oven if it is damaged, in particular, if the door or door seals are damaged. Door damage includes a broken hinge, a worn out seal, or a distorted/bent casing.
- Do not remove the oven from its casing.
- This microwave oven is for home use only and is not intended for commercial use.

## REPLACING THE COOKTOP/NIGHT LIGHT

When replacing the cooktop/night light, make sure that you are wearing gloves to avoid injury from the heat of the bulb.

1. Unplug the oven or turn off the power at the main power supply.
2. Remove the screw from the light cover and lower the cover.
3. Replace the bulb with a 20 watt halogen lamp.
4. Replace the light cover and mounting screw.
5. Turn the power back on at the main power supply or plug the microwave in.

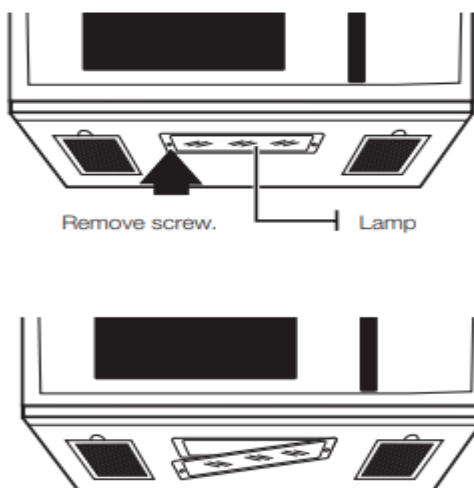

## REPLACING THE OVEN LIGHT

When replacing the oven light, make sure that you are wearing gloves to avoid injury from the heat of the bulb.

1. Unplug the oven or turn off the power at the main power supply.
2. Open the door.
3. Remove the vent cover mounting screws (2 middle screws).
4. Slide the vent grille to the left, then pull it straight out.
5. Remove the charcoal filter, if present.
6. Remove the cover by pushing the hook and pulling up the lever.
7. Remove the bulb by turning it gently.
8. Replace the bulb with a 40 watt appliance bulb.
9. Replace the bulb holder.
10. Replace the vent grille and the 2 screws.
11. Turn the power back or plug the microwave in.

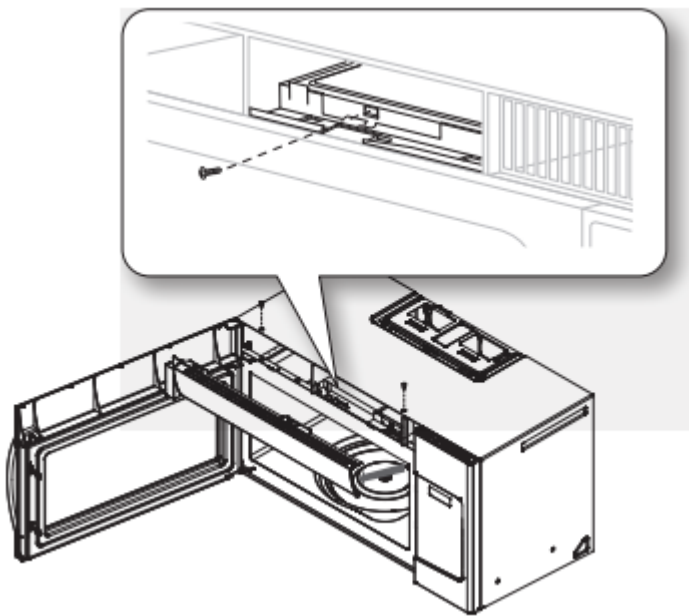

## CLEANING THE GREASE FILTER

Your microwave oven has reusable grease filter. The grease filters should be removed and cleaned at least once every four months or as required.

To order a new grease filter, contact SamsungParts at 1-800-627-4368 or your Samsung dealer.



Your microwave oven has a filter reminder function. See page 10 for details.



**WARNING** To avoid risk of personal injury or property damage, do not operate the oven hood without the filters in place.

1. To remove the filter, slide them to the rear using the tabs, then pull down and out.



2. Soak the grease filter in hot water and a mild detergent. Rinse well and shake to dry. Brushing the filter lightly can remove embedded dirt.



**WARNING** Do not use ammonia or put the grease filter in the microwave oven cavity to dry. The aluminum will darken.

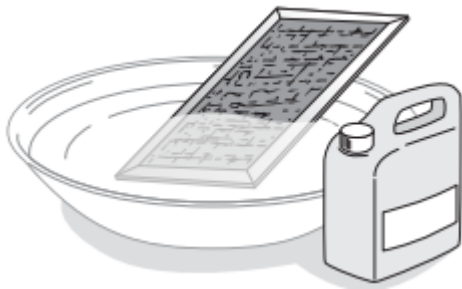

3. To re-install the filter, slide it into the frame slots on the back of each opening, and then press up and to the front to lock it.

## REPLACING THE CHARCOAL FILTER

If your oven is vented to the inside, the charcoal filter should be replaced every 6 to 12 months and more often if necessary. The charcoal filter cannot be cleaned. To order a new charcoal filter, contact SamsungParts at 1-800-627-4368 or your Samsung dealer.

1. Unplug the oven or turn off the power at the main power supply.
2. Open the door.
3. Remove the vent grille mounting screws (2 middle screws).
4. Slide the vent grille to the left, then pull it straight out.
5. Push the hook, and then remove the old filter.

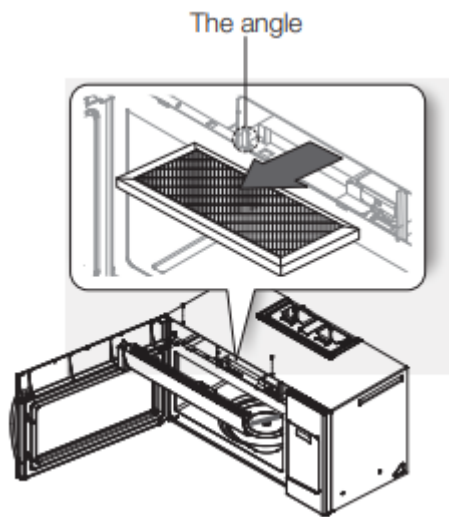

6. Slide a new charcoal filter into place. The filter should rest at the angle shown.

7. Replace the vent grille and 2 screws, and then close the door. Turn the power back on, and then set the clock.

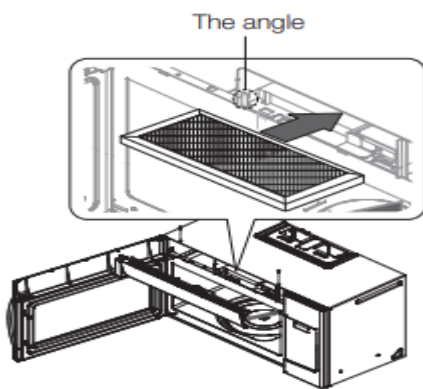

## Troubleshooting

Check these solutions if you have a problem with your microwave:

<b>Problem</b>	<b>Solutions</b>
The display and/or the oven is not working.	<p>Make sure the plug is properly connected to a grounded outlet.</p> <p>If the wall outlet is controlled by a wall switch, make sure the wall switch is turned on.</p> <p>Remove the plug from the outlet, wait ten seconds, and plug it in again.</p> <p>Reset the circuit breaker or replace any blown fuses.</p> <p>Plug a different appliance into the outlet. If the other appliance doesn't work, call a qualified electrician to repair the wall outlet.</p> <p>Plug the oven into a different outlet.</p>
The display is working, but the power won't come on.	<p>Make sure the door is closed securely.</p> <p>Check if any packaging material or anything else is stuck in the door seal. Check if the door is damaged.</p> <p>Touch Cancel twice and enter all the cooking instructions again.</p>
Is the power going off before the set time has elapsed?	<p>If there was a power outage, the time indicator will display: 88:88.</p> <p>If no power outage occurred, remove the plug from the outlet, wait ten seconds, and plug it in again.</p> <p>Reset the clock and any cooking instructions.</p> <p>Reset the circuit breaker or replace any blown fuses.</p>
Cooks food too slowly.	<p>Make sure the oven has its own 15 to 20 amp circuit line. Operating another appliance on the same circuit can cause a voltage drop. If necessary, move the oven to its own circuit.</p>
Has sparks or arcing.	<p>Remove any metallic utensils, cookware, or metal ties. If using foil, use only narrow strips and allow at least one inch between the foil and the interior oven walls.</p>
	<p>Clean the turntable, roller ring, and oven floor.</p>

The turntable makes noise or becomes stuck.	Make sure the turntable and roller ring are positioned correctly.
Causes TV or radio interference.	This is similar to interference caused by other small appliances, such as hair dryers. Move your microwave (or appliance) away from the affected appliances, such as your TV or radio.
Vent Motor suction force is too weak.	Set the vent mode to high. The Vent Fan will only operate in low speed mode while the microwave is working.
Operating noise is too loud.	The microwave makes noise during operation. This is normal. If you hear an abnormal sound continuously, please contact the Samsung Call Center (1-800-726- 7864).
Cook top lamp is too dim.	Set the lamp brightness level to high.
Difficult to replace Charcoal Filter.	Please refer to the instructions for replacing the charcoal filter in the user's manual.
Turntable rotates improperly	Make sure you have not put too much food on the turntable. If the food is too large or too heavy, the turntable may operate improperly

### Warning

This content is compiled from multiple sources and is provided for reference purposes only. It may not be complete or fully applicable to all situations. If you are unable to resolve your issue, please contact the product manufacturer or an authorized service provider for official support.