

PARTS & ACCESSORIES

PARTS

- A. Deluxe Layer
- B. Deluxe Reversible Rack
- C. Cook & Crisp™ Basket
- D. Detachable Diffuser
- E. 8-Quart Removable Cooking Pot
- F. Crisping Lid
- G. Heat Shield
- H. Control Panel
- I. Cooker Base
- J. Pressure Lid
- K. Pressure Release Valve
- L. Float Valve
- M. Silicone Ring
- N. Anti-Clog Cap
- O. Air Outlet Vent
- P. Condensation Collector

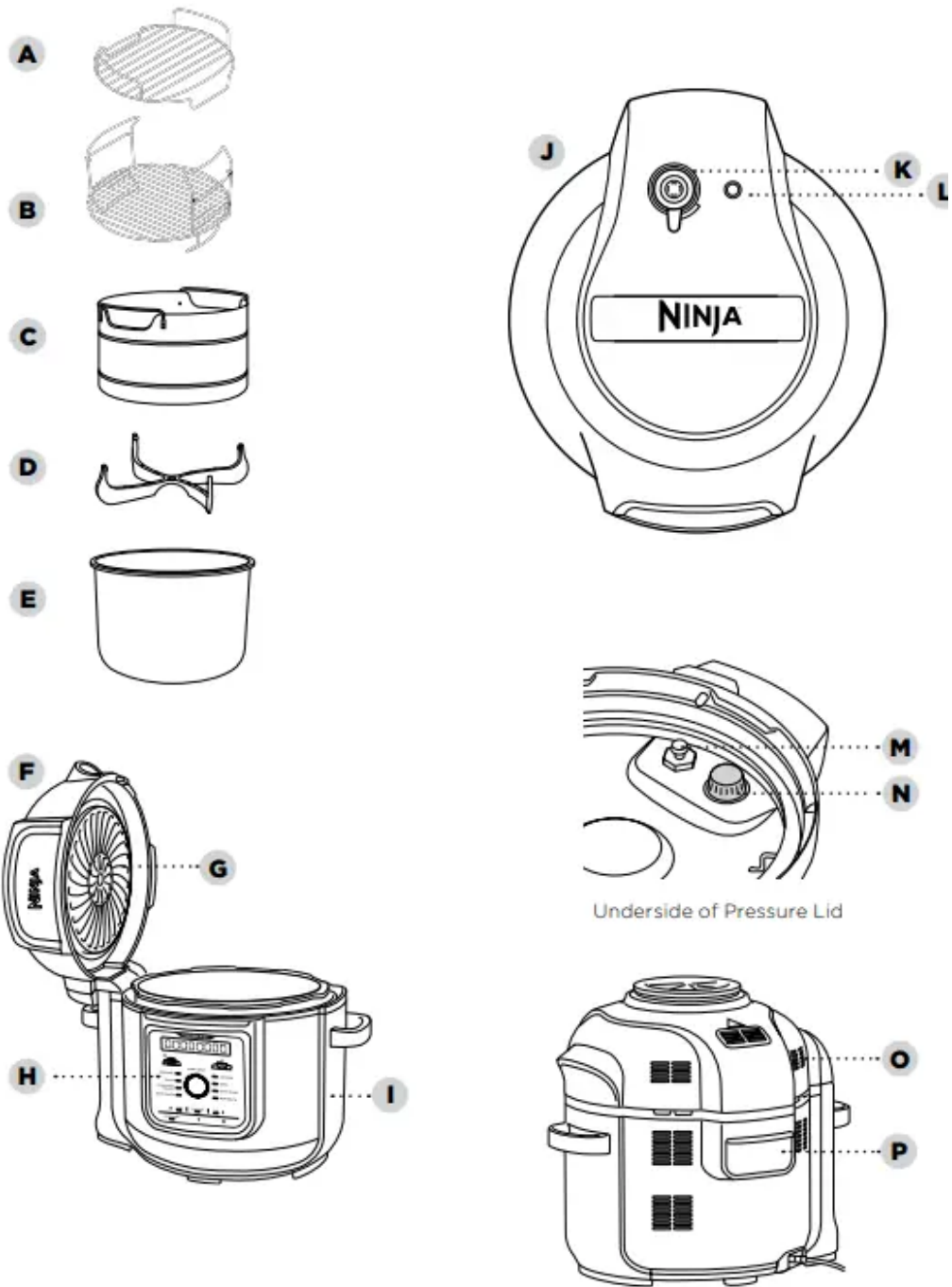



ACCESSORY ASSEMBLY INSTRUCTIONS

DELUXE REVERSIBLE RACK



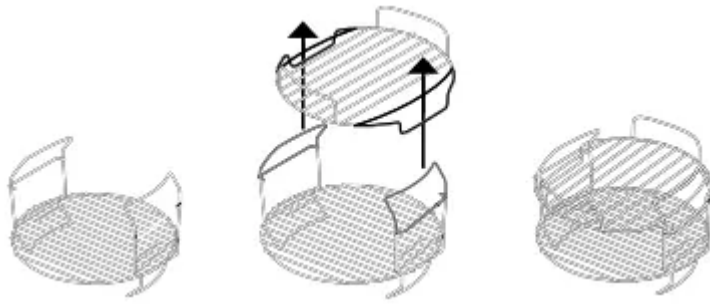

1. Place the reversible rack in the pot in the lower position.
2. Drop deluxe layer through reversible rack handles.

COOK & CRISPTM BASKET

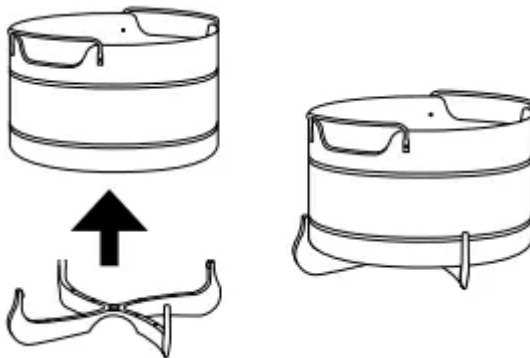

1. To remove diffuser for cleaning, pull 2 diffuser fins off the groove on the basket, then pull down firmly.
2. To assemble the Cook & Crisp Basket, place basket on top of diffuser and press down firmly

USING THE CONTROL PANEL

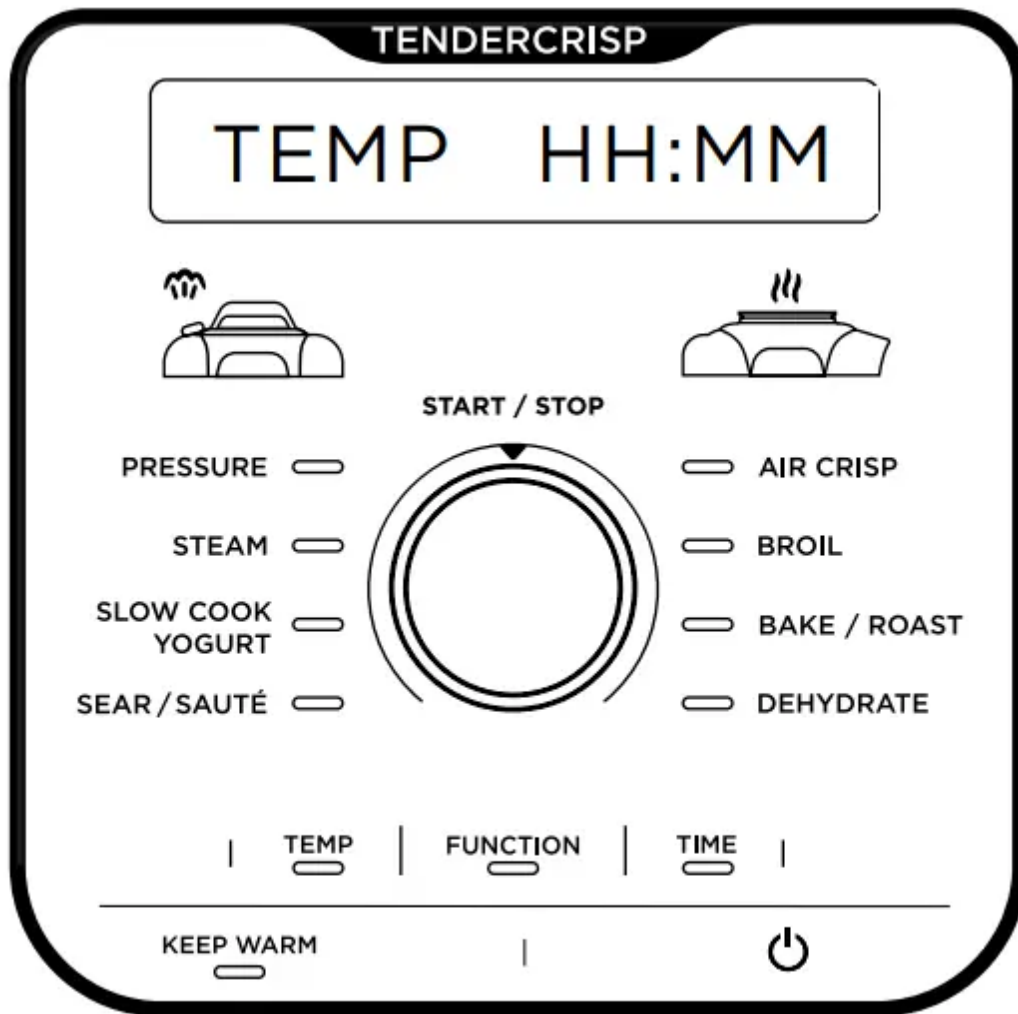

NOTE: Control panel may differ per model.

COOKING FUNCTIONS

PRESSURE: Cook food quickly while maintaining tenderness.

STEAM: Gently cook delicate foods at a high temperature.

SLOW COOK: Cook your food at a lower temperature for a longer period of time.

YOGURT: Pasteurize and ferment milk for creamy homemade yogurt.

SEAR/SAUTÉ: Use the unit as a stovetop for browning meats, sautéing veggies, simmering sauces, and more.

AIR CRISP: Give foods crispiness and crunch with little to no oil.

BROIL: Use high temperature to caramelize and brown your food.

BAKE/ROAST: Use the unit like an oven for tender meats, baked treats, and more.

DEHYDRATE: Dehydrate meats, fruits, and vegetables for healthy snacks.

OPERATING BUTTONS

FUNCTION: Press FUNCTION, then turn the START/STOP dial to choose a cooking function.

TEMP: Press TEMP, then turn the

START/STOP dial to adjust cooking temperature in increments of 5 degrees or to adjust the pressure level.

TIME: Press TIME, then turn the

START/STOP dial to adjust the cook time.

START/STOP dial/button: Turn the dial to choose a cooking function, cook temperature, and cook time. Press the button to start cooking. Pressing the button while the unit is cooking will stop the current cooking function.

KEEP WARM: After pressure cooking, steaming, or slow cooking, the unit will automatically switch to Keep Warm mode and start counting up. Keep Warm will stay on for 12 hours, or you may press KEEP WARM to turn it off. Keep Warm mode is not intended to warm food from a cold state but to keep it warm at a food-safe temperature.

POWER: The Power button shuts the unit off and stops all cooking modes

BEFORE FIRST USE

1. Remove and discard any packaging material, stickers, and tape from the unit.
2. Pay particular attention to operational instructions, warnings, and important safeguards to avoid any injury or property damage.
3. Wash the pressure lid, silicone ring, removable cooking pot, Cook & Crisp™ Basket, deluxe reversible rack, and condensation collector in warm, soapy water, then rinse and dry thoroughly. **NEVER** clean the cooker base in the dishwasher. Inspect the pressure lid to ensure there is no debris blocking the valves.
4. The silicone ring is reversible and can be inserted in either direction. Insert the silicone ring around the outer edge of the silicone ring rack on the underside of the lid. Ensure it is fully inserted and lies flat under the silicone ring rack.

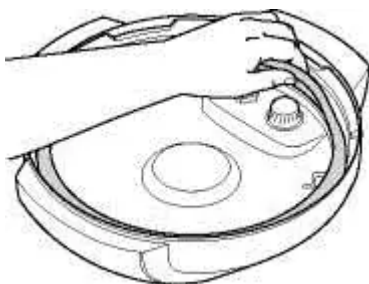

INSTALLING THE CONDENSATION COLLECTOR

To install the condensation collector, slide it into the slot on the cooker base. Slide it out to remove it for hand-washing after each use.

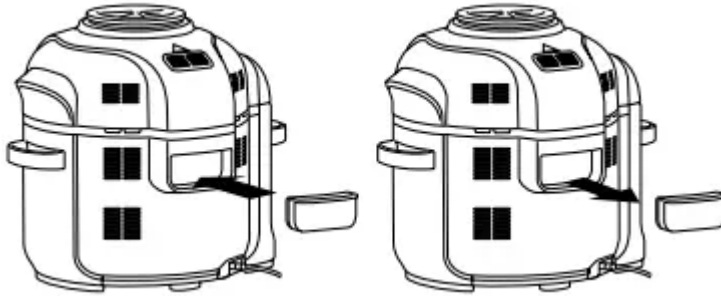

REMOVING & REINSTALLING THE ANTI-CLOG CAP

Make sure the anti-clog cap is in the correct position before using the pressure lid. The anti-clog cap protects the inner valve of the pressure lid from clogging and protects users from potential food splatters. It should be cleaned after every use with a cleaning brush.

To remove it, grasp firmly and pull upward. To reinstall, position it in place and press down.

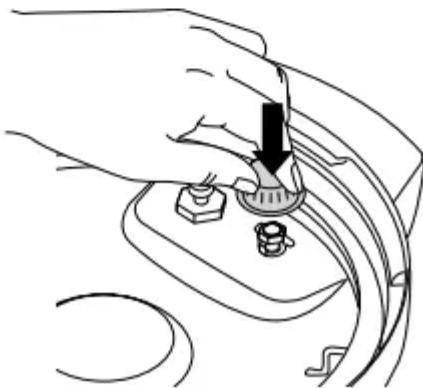
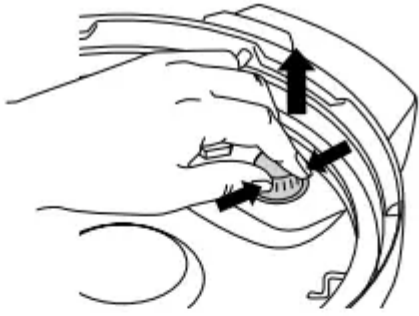

USING YOUR FOODI™ DELUXE TENDERCRISP™ PRESSURE COOKER

SWAP THE TOP

The two lids allow you to seamlessly transition between all your favorite cooking methods. Use the pressure lid to tenderize, then use the crisping lid to crisp up your food.

USING THE CRISPING LID

The crisping lid is attached to the unit and can be opened at any time to check on your food during the cooking process. When the lid is opened, the timer will pause, and the heating element will turn off. When the lid is closed, cooking will begin again and the timer will resume counting down.

USING THE COOKING FUNCTIONS WITH THE CRISPING LID

To turn on the unit, plug the power cord into a wall outlet, then press the .

Air Crisp

1. Place either the Cook & Crisp™ Basket or deluxe reversible rack in the pot. Basket should have diffuser attached.

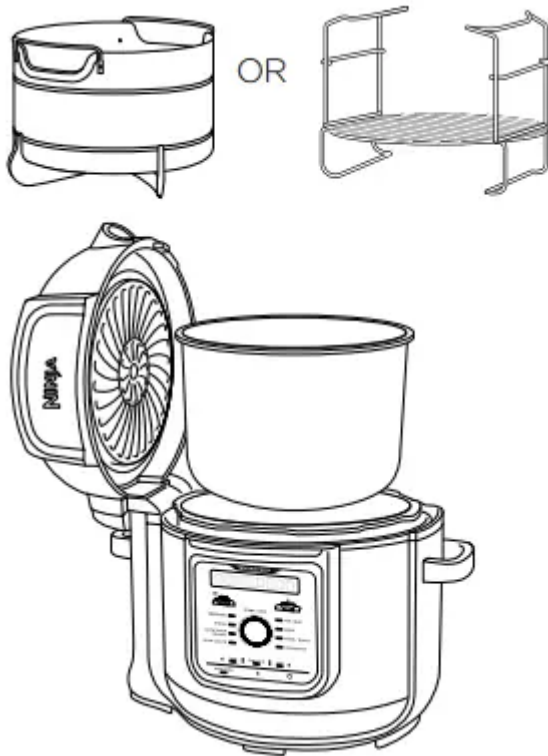

2. Add ingredients to the Cook & Crisp Basket or deluxe reversible rack. Close the lid.

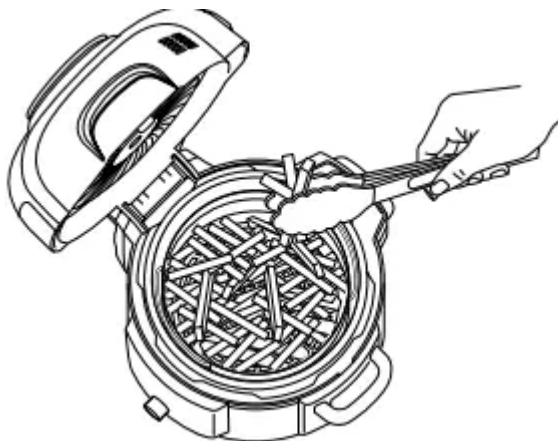

3. Press FUNCTION, then turn the

START/STOP dial to select AIR CRISP. The default temperature setting will display. Press TEMP, then turn the dial to choose a temperature between 300°F and 400°F.



4. Press TIME, then turn the START/STOP dial to adjust the cook time in minute increments up to 1 hour. To preheat your unit, simply add an additional 5 minutes to the cook time. Press START/STOP to begin cooking.

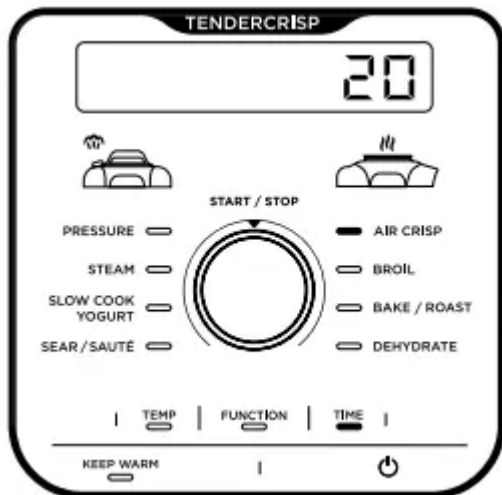

5. During cooking, you can open the lid and lift out the basket to shake or toss ingredients for even browning, if needed. When done, lower basket back into pot and close lid. Cooking will automatically resume after lid is closed.

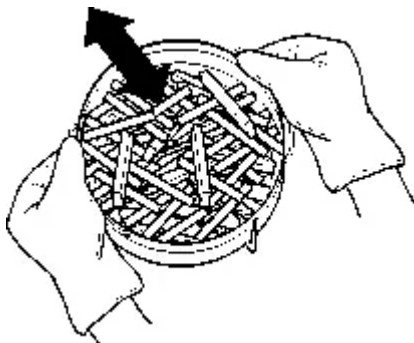

6. When cook time is complete, the unit will beep and display DONE.

Broil

1. Place the deluxe reversible rack in the pot in the higher broil position or follow the directions in your recipe.

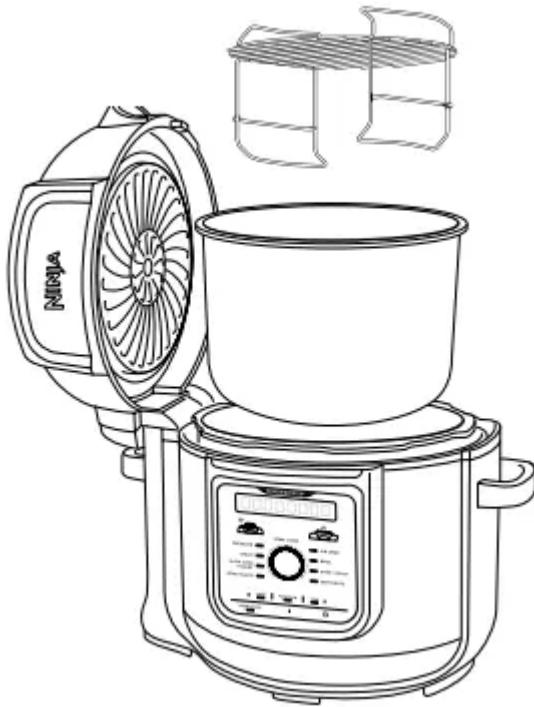

2. Place ingredients on the rack, then close the lid.

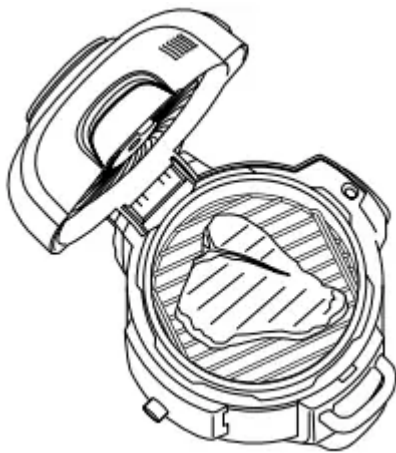

3. Press FUNCTION, then turn the START/STOP dial to select BROIL



4. Press TIME, then turn the dial to adjust the cook time in minute increments up to 30 minutes.

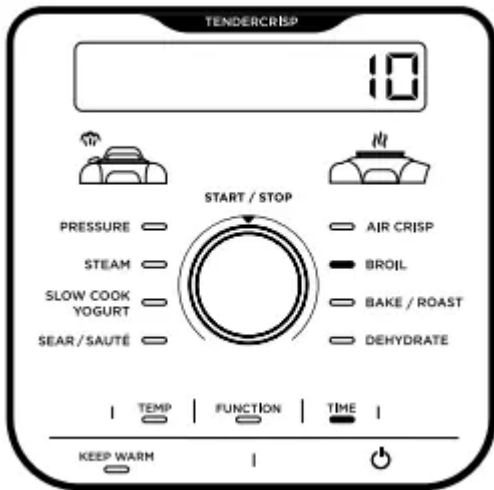

5. Press START/STOP to begin cooking.

6. When cook time is complete, the unit will beep and display DONE.



Bake/Roast

1. Add ingredients and any accessories to the pot. Close the lid.
2. Press FUNCTION, then turn the START/STOP dial to select BAKE/ROAST. The default temperature setting will display. Press TEMP, then turn the dial to select a temperature between 250°F and 400°F.



3. Press TIME, then turn the START/STOP dial to adjust the cook time in minute increments up to 1 hour and then 5-minute increments from 1 hour to 4 hours. Press START/STOP to begin cooking.

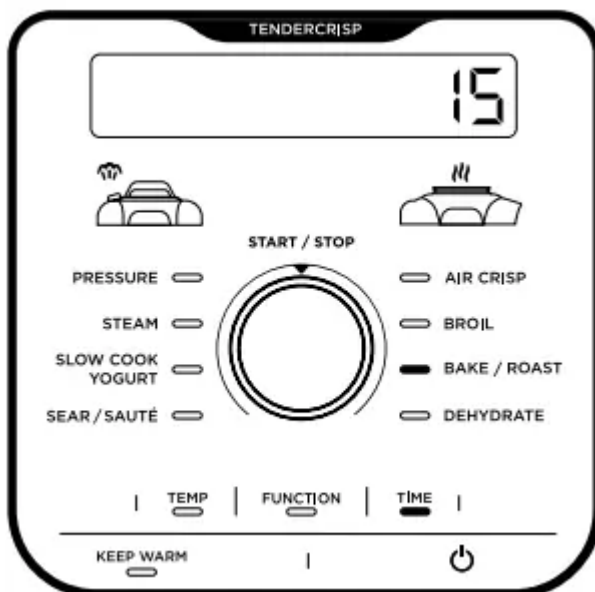

4. When cook time is complete, the unit will beep and display DONE.

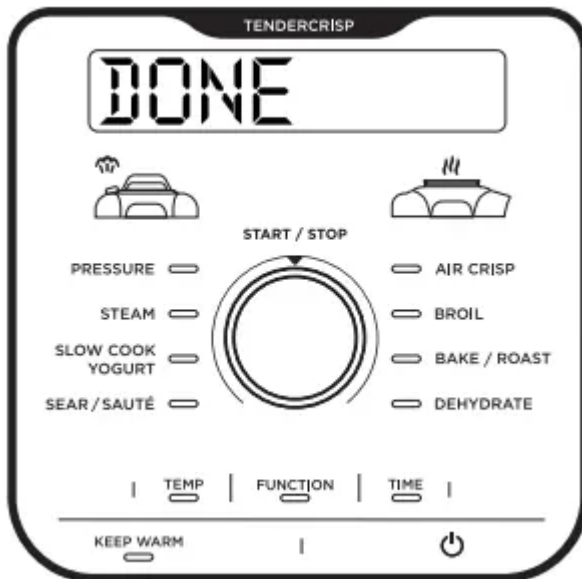

Dehydrate

1. Place the deluxe reversible rack in the pot in the lower position, then place a layer of ingredients on the rack.



2. Holding the deluxe layer by its handles, place it down over the reversible rack in the position shown below. Then place a layer of ingredients on the deluxe layer and close the lid.



3. Press FUNCTION, then turn the START/STOP dial to select DEHYDRATE. The default temperature setting will display. Press TEMP, then turn the dial to choose a temperature between 80°F and 195°F

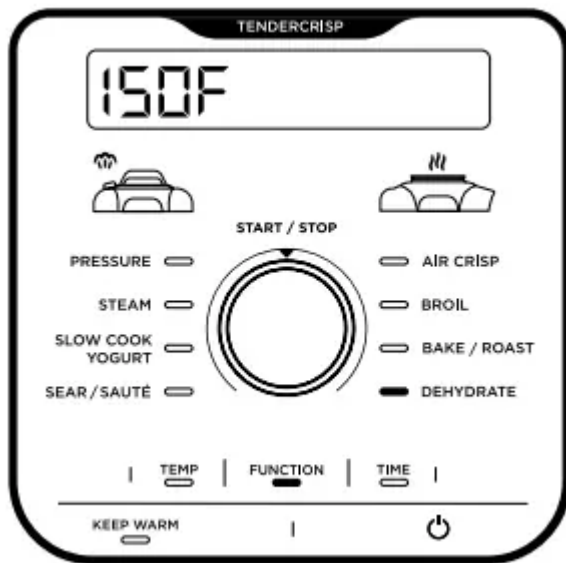

4. Press TIME, then turn the dial to adjust the cook time in 15-minute increments up to 12 hours.





5. Close the lid and press START/STOP to begin dehydrating.

6. When cook time is complete, the unit will beep and display DONE



INSTALLING & REMOVING THE PRESSURE LID

1. Place the pressure lid on top of the unit with the  on the lid and the  on the base lined up evenly. Turn the lid clockwise until it locks in place.

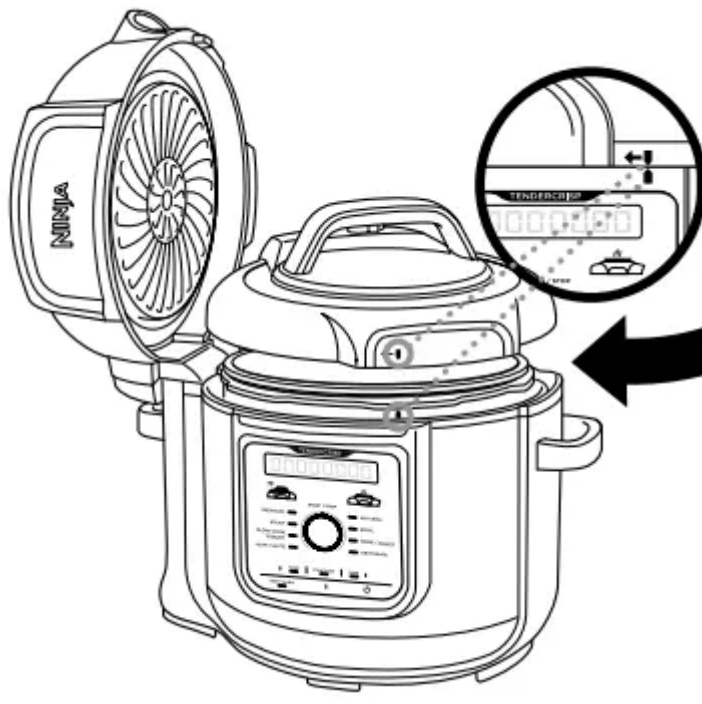

2. Pressure Lid is locked when it has clicked into place and the Ninja Logo is facing you.

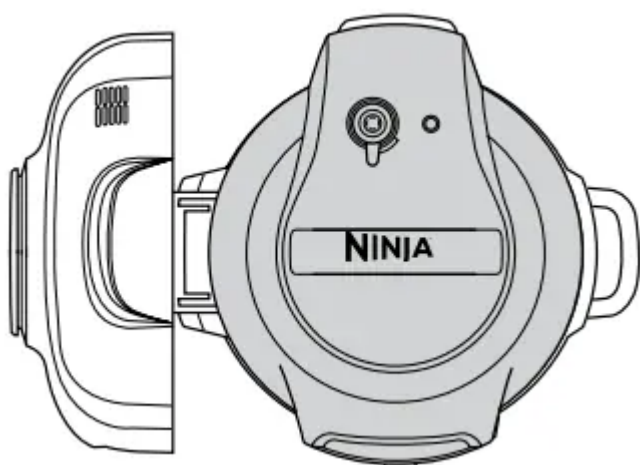

3. To unlock the pressure lid, turn it counterclockwise. Lift it up and away from you, as some steam will remain in the unit and escape when the lid is opened.



SEAL
for Pressure Cook



VENT
for Steam, Slow Cook,
and Sear/Sauté

WATER TEST: GETTING STARTED PRESSURE COOKING

It is recommended that first-time users do the water test to familiarize themselves with Pressure Cooking.

1. Place the pot in the cooker base and add 3 cups of room-temperature water to the pot.

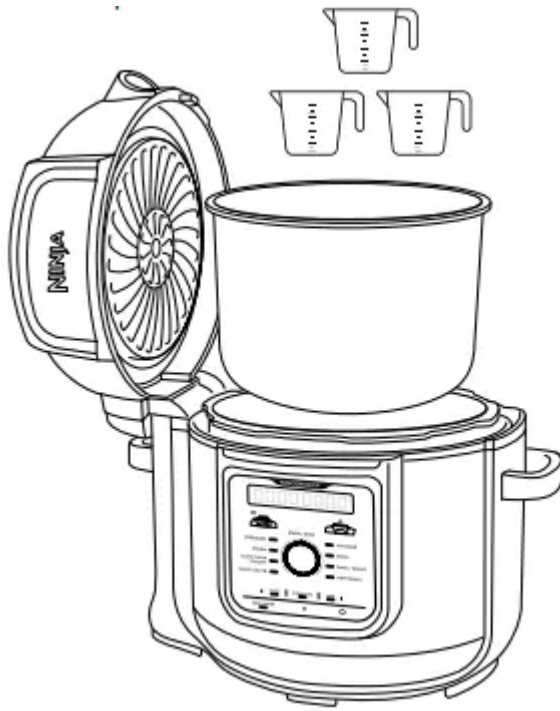

2. Assemble the pressure lid by aligning the arrow on the front of the lid with the arrow on the front of the cooker base. Then turn the lid clockwise until it locks into place.

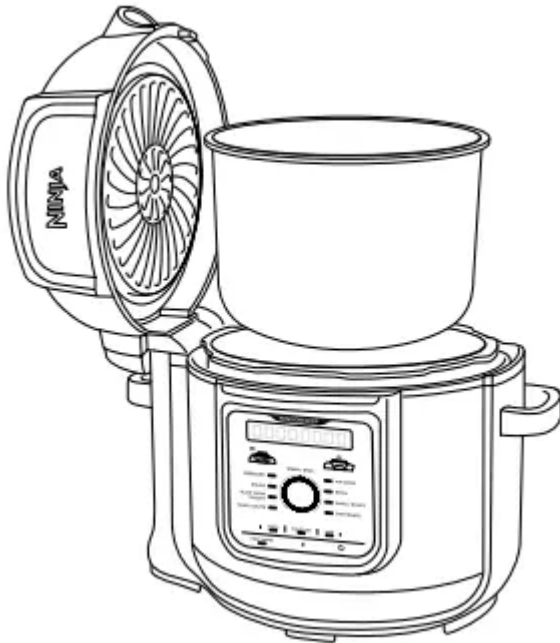

3. Make sure the pressure release valve is in the SEAL position.



4. Press FUNCTION, then turn the START/STOP dial to select PRESSURE. The unit will default to high (HI) pressure and a time setting of 2 minutes. Press START/STOP to begin.



5. The display showing PRE and some steam release indicate pressure is building. When fully-pressurized, countdown will begin.

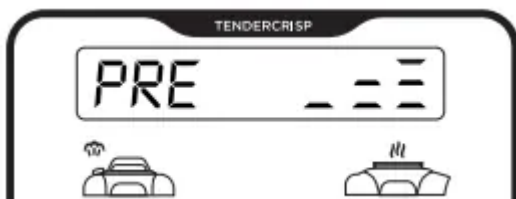

6. When the countdown is finished, the unit will beep and display DONE before automatically switching to KEEP WARM mode, and begin counting up.



7. Turn the pressure release valve to the VENT position to quick release the pressurized steam. There will be a burst of steam from the pressure release valve. When steam is completely released, float valve will drop and the lid can be opened.



NATURAL PRESSURE RELEASE VS. QUICK PRESSURE RELEASE

Natural Pressure Release: When pressure cooking is complete, steam will naturally release from the unit as it cools down. This can take upwards of 20 minutes, depending on the amount of ingredients in the pot. During this time, the unit will switch to Keep Warm mode. Press KEEP WARM if you would like to turn Keep Warm mode off. When natural pressure release is complete, the float valve will drop down.

Quick Pressure Release: Use ONLY if your recipe calls for it. After pressure cooking and the KEEP WARM light comes on, turn the pressure release valve to the VENT position to quickly release the steam. Steam release will be accompanied by an audible hiss. Some steam will remain in the unit after pressure release and will escape when the lid is opened. Lift and tilt it away from you, making sure no condensation drips into the cooker base.



PRESSURIZING

As pressure builds in the unit, the control panel will display PRE. Time to pressure varies based on the amount and temperature of ingredients as well as liquid in the pot. For safety, the lid will lock as the unit pressurizes, and it will not unlock until pressure is released. Once the unit has reached full pressure, the cooking cycle will begin and the timer will start counting down.

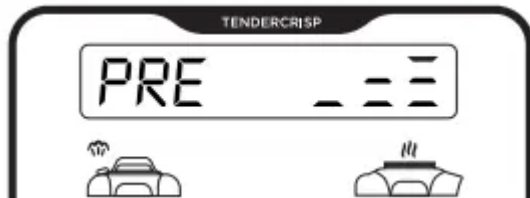

USING THE COOKING FUNCTIONS WITH THE PRESSURE LID

To turn on the unit, plug the power cord into a wall outlet, then press the .

Pressure Cook

1. Place ingredients and at least 1 cup of liquid in the pot, as well as any necessary accessory.

DO NOT fill the pot past the PRESSURE MAX line.

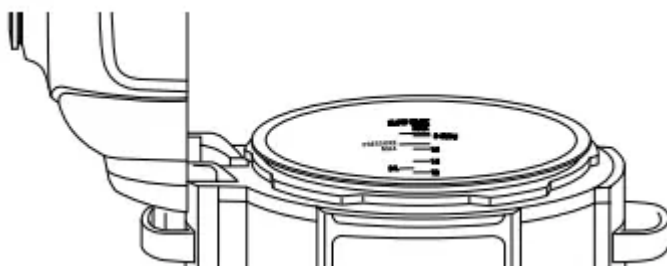

2. Install the pressure lid and turn the pressure release valve to the SEAL position.



3. Press FUNCTION, then turn the START/STOP dial to select PRESSURE. The default pressure level will display. Press TEMP, then turn the dial to select HI or LO.



4. Press TIME, then turn the dial to adjust the cook time in minute increments up to 1 hour, and then 5-minute increments from 1 hour to 4 hours.



5. Press START/STOP to begin cooking. The unit will begin to build pressure, and PRE will be shown on the display. The unit will begin counting down when it is fully pressurized.



6. When cook time is complete, the unit will beep, automatically switch to Keep Warm mode, and begin counting up.



7. Let the unit naturally release pressure or, if the recipe instructs, turn the pressure release valve to the VENT position to quick release the steam



Steam

1. Add 1 cup of liquid (or recipe-specified amount) to the pot, then place the reversible rack or Cook & Crisp™ Basket with ingredients in the pot.

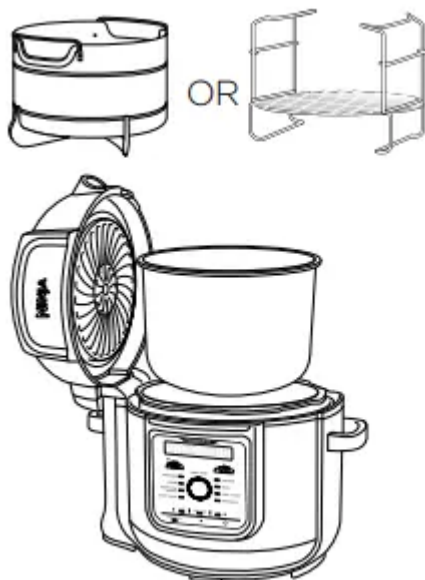

2. Install the pressure lid and turn the pressure release valve to the VENT position.



3. Press FUNCTION, then turn the START/STOP dial to select STEAM.

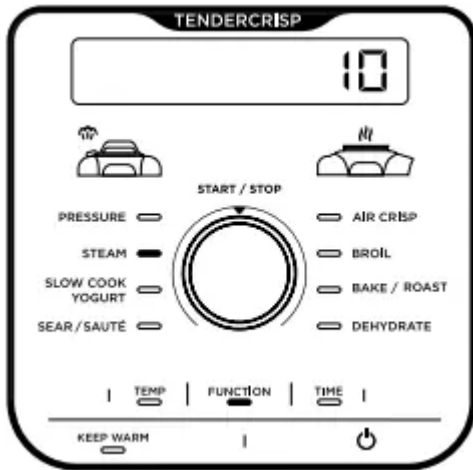

4. Press TIME, then turn the dial to adjust the cook time in minute increments up to 30 minutes. Press START/STOP to begin cooking.

5. The unit will begin preheating to bring the liquid to a boil. The display will show PRE. The preheating animation will show until the unit reaches temperature and then the display will show BOIL and the timer will begin counting down.

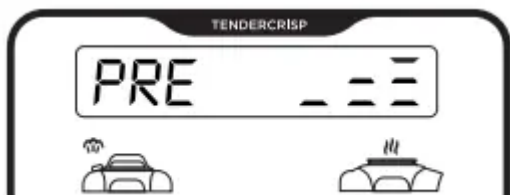

6. When cook time is complete, the unit will beep and automatically switch to Keep Warm mode and begin counting up. Ensure the float valve has dropped before opening the lid.



Slow Cook

1. Add ingredients to the pot. DO NOT fill the pot past the MAX line.
2. Install the pressure lid and turn the pressure release valve to the VENT position.



- 3 Press FUNCTION, then turn the START/STOP dial to select SLOW COOK. The default temperature setting will display. Press TEMP, then turn the dial to select HI or LO.

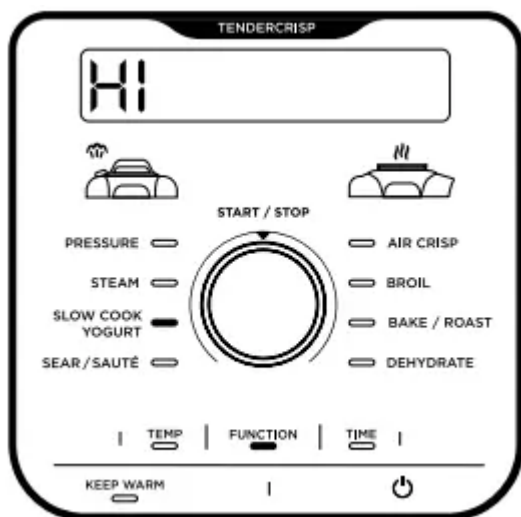

4. Press TIME, then turn the dial to adjust the cook time in 15-minute increments up to 12 hours.

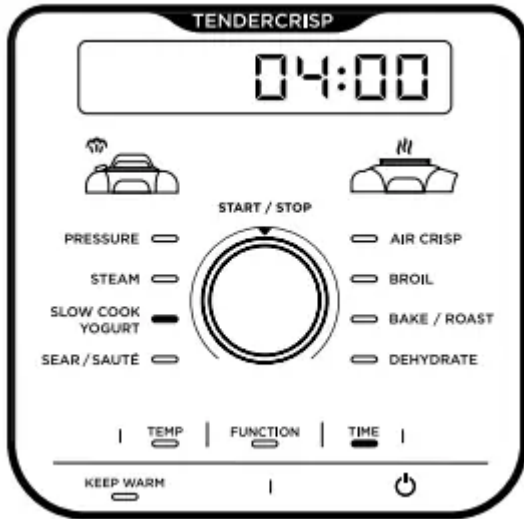

5. Press START/STOP to begin cooking.

6. When cook time is complete, the unit will beep, automatically switch to Keep Warm mode, and begin counting up

Yogurt

1. Add desired amount of milk to the pot.

2. Install the pressure lid and turn the pressure release valve to the VENT position.



3. Press FUNCTION, then turn the START/STOP dial to select YOGURT. The default temperature setting will display. Press TEMP, then turn the dial to select YGRT or FMNT.

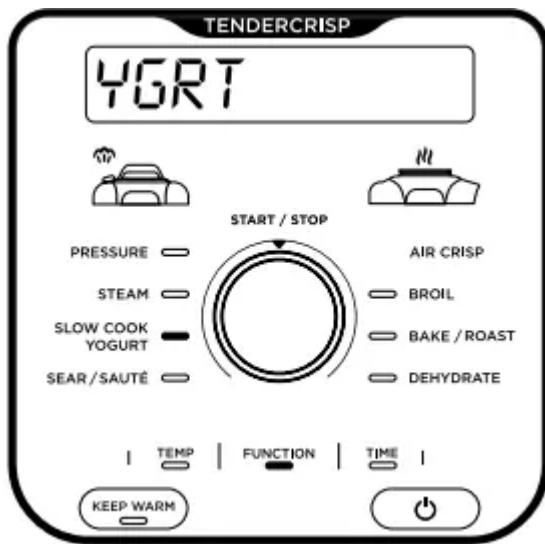

4. Press TIME, then turn the dial to adjust the incubation time in 30-minute increments between 8 and 12 hours



5. Press START/STOP to begin pasteurization.

6. Unit will display BOIL while pasteurizing. When pasteurization temperature is reached, the unit will beep and display COOL.

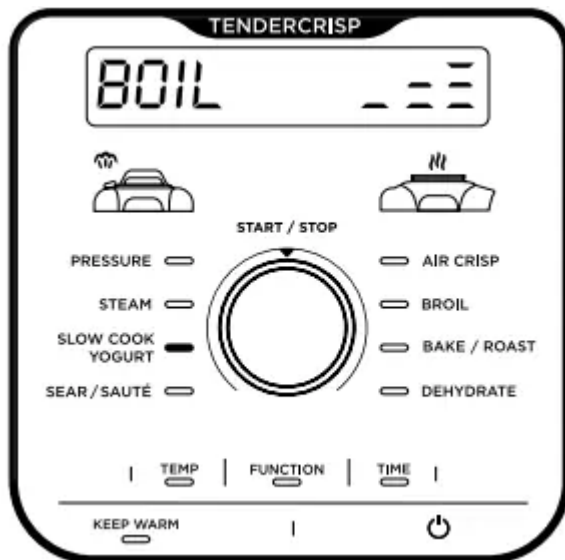

7. Once the milk has cooled, the unit will display ADD And STIR in succession and the incubation time.

8. Remove the pressure lid and skim the top of the milk.

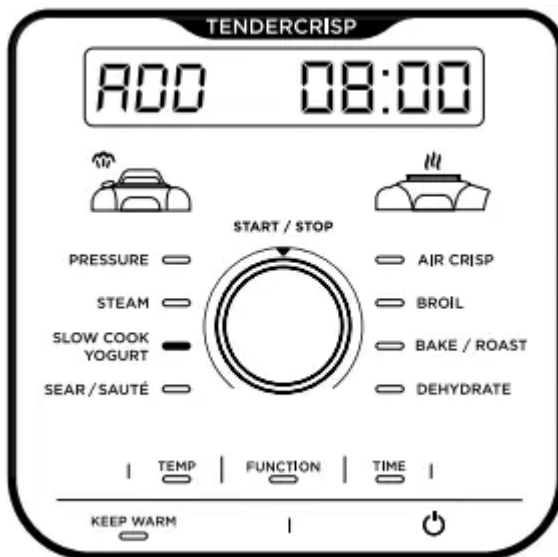

9. Add yogurt cultures to milk and stir to combine. Install the pressure lid and press START/STOP to begin incubation process.





10. The display will show FMNT and will begin counting down. When incubation time is complete, the unit will beep and display DONE. The unit will beep each minute for up to 4 hours or until powered off.

11. Chill yogurt up to 12 hours before serving.

Sear/Sauté

1. Add ingredients to the pot.

2. Press FUNCTION, then turn the dial to select SEAR/SAUTÉ. The default temperature setting will display. Press TEMP, then turn the dial to select LO, LO:MD, MD, MD:HI, or HI.

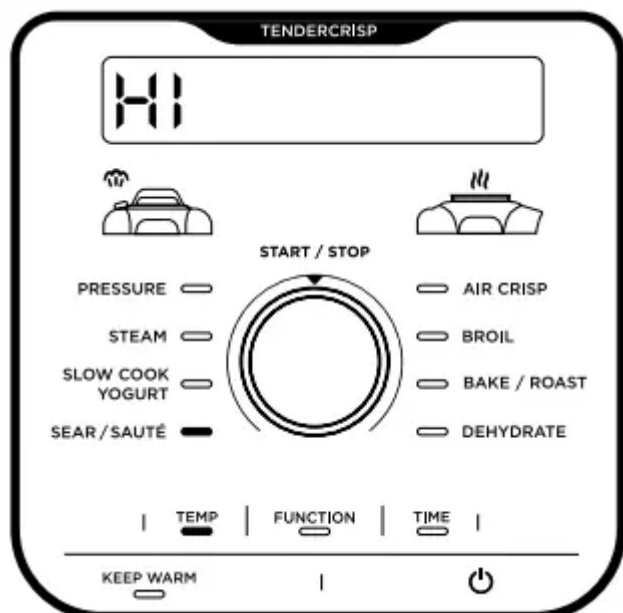

3. Press START/STOP to begin cooking.

4. Press START/STOP to turn off the SEAR/SAUTÉ function. To switch to a different cooking function, press FUNCTION, then turn the START/STOP dial to your desired cooking function.

CLEANING & MAINTENANCE

Cleaning: Dishwasher & Hand-Washing

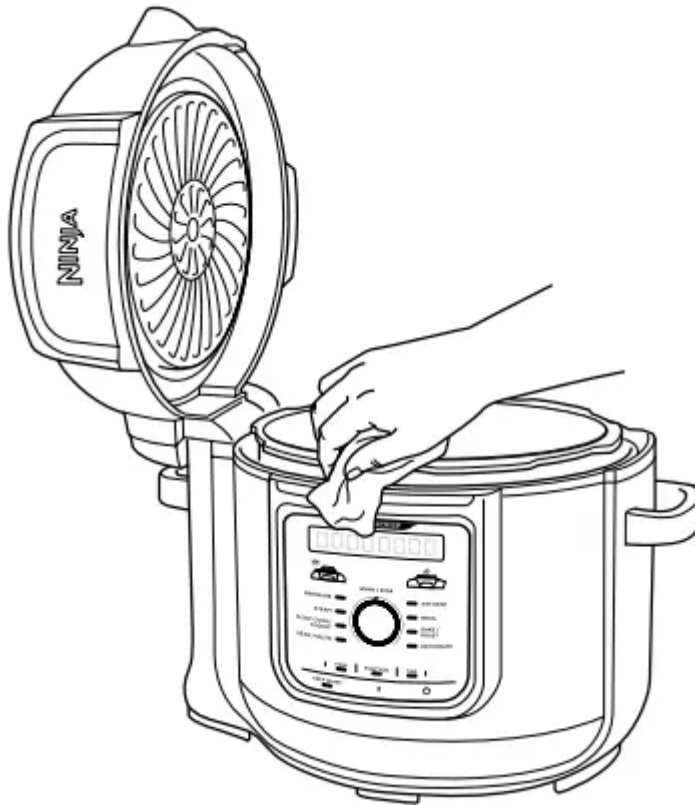

The unit should be cleaned thoroughly after every use.

1. Unplug the unit from the wall outlet before cleaning.
2. To clean the cooker base and the control panel, wipe them clean with a damp cloth.
3. The pressure lid, cooking pot, silicone ring, deluxe reversible rack, Cook & Crisp™ Basket, and detachable diffuser can be washed in the dishwasher.
4. The pressure lid, including the pressure release valve and anti-clog cap, can be washed with water and dish soap.
5. To clean the crisping lid, wipe it down with a wet cloth or paper towel after the heat shield cools.
6. If food residue is stuck on the cooking pot, deluxe reversible rack, or Cook & Crisp Basket, fill the pot with water and allow to soak before cleaning. **DO NOT** use scouring pads. If scrubbing is necessary, use a non-abrasive cleanser or liquid dish soap with a nylon pad or brush.
7. Air-dry all parts after each use.

Removing & Reinstalling the Silicone Ring

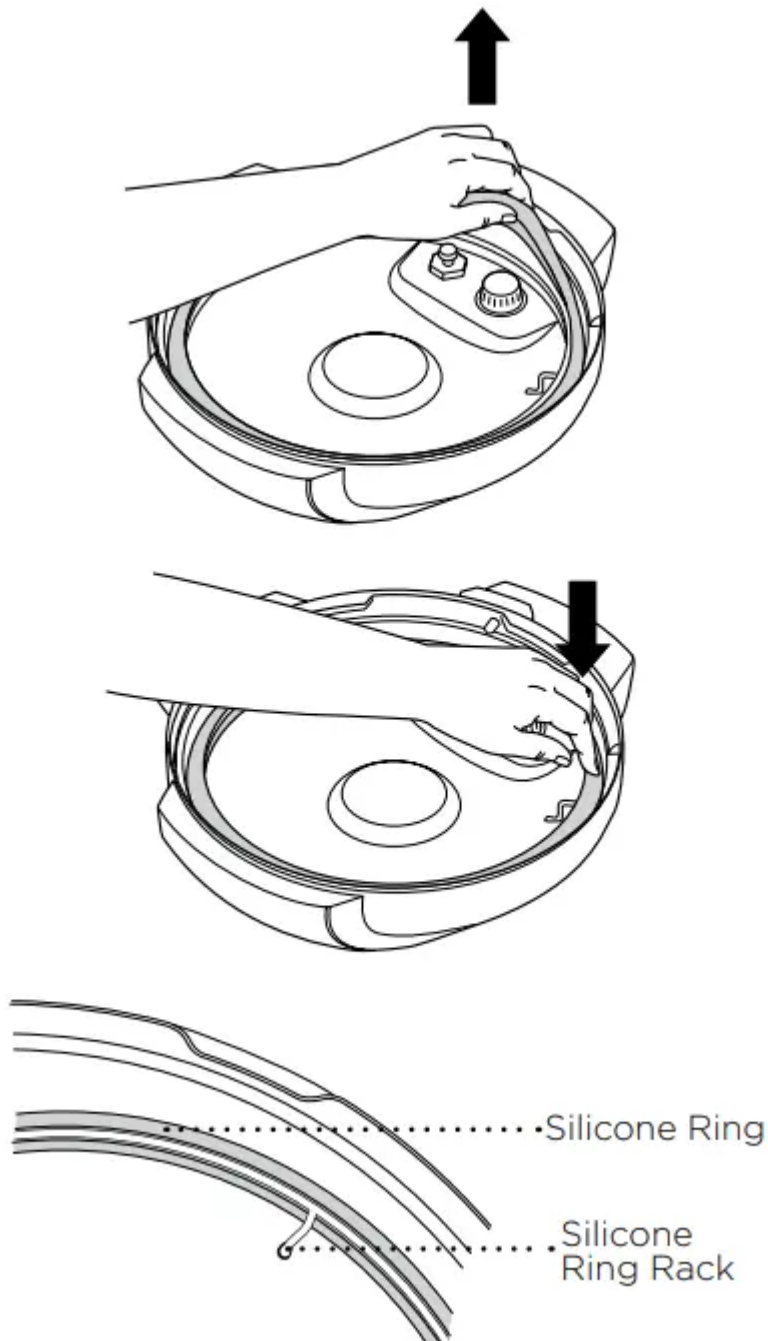

To remove the silicone ring, pull it outward, section by section, from the silicone ring rack. The ring can be installed with either side facing up. To reinstall, press it down into the rack section by section.

After use, remove any food debris from the silicone ring and anti-clog cap.

Keep the silicone ring clean to avoid odor. Washing it in warm, soapy water or in the dishwasher can remove odor. However, it is normal for it to absorb the smell of certain acidic foods. It is recommended to have more than one silicone ring on hand. You can purchase additional silicone rings on ninjaccessories.com. **NEVER** pull out the silicone ring with excessive force, as that may deform it and the rack and affect the pressure-sealing function. A silicone ring with cracks, cuts, or other damage should be replaced immediately.

TROUBLESHOOTING GUIDE

Why is my unit taking so long to come to pressure? How long does it take to come to pressure?

- Cooking times may vary based on the selected temperature, current temperature of the cooking pot, and temperature or quantity of the ingredients.
- Check to make sure your silicone ring is fully seated and flush against the lid. If installed correctly, you should be able to tug lightly on the ring to rotate it.
- Check that the pressure lid is fully locked, and the pressure release valve is in the SEAL position when pressure cooking.

Why is the time counting down so slowly?

- You may have set hours rather than minutes. When setting time, the display will show HH:MM and the time will increase/decrease in minute increments.

How can I tell when the unit is pressurizing?

- The display will show PRE and the building animation to indicate the unit is building pressure.

PRE and moving lights are shown on the display screen when using the Pressure or Steam function.

- This indicates the unit is building pressure or preheating when using STEAM or PRESSURE. When the unit has finished building pressure, your set cook time will begin counting down.

There is a lot of steam coming from my unit when using the Steam function.

- It's normal for steam to release through the pressure release valve during cooking. Leave the pressure release valve in the VENT position for Steam, Slow Cook, and Sear/Sauté.

Why can't I take the pressure lid off?

- As a safety feature, the pressure lid will not unlock until the unit is completely depressurized. Turn the pressure release valve to the VENT position to quick release the pressurized steam. A quick burst of steam will spurt out of the pressure release valve. When the steam is completely released, the unit will be ready to open. Turn the pressure lid counterclockwise, then lift it up and away from you.

Is the pressure release valve supposed to be loose?

- Yes. The pressure release valve's loose fit is intentional; it enables a quick and easy transition between SEAL and VENT and helps regulate pressure by releasing small amounts of steam during cooking to ensure great results. Please make sure it is turned

as far as possible toward the SEAL position when pressure cooking and as far as possible toward the VENT position when quick releasing.

The unit is hissing and not reaching pressure.

- Make sure the pressure release valve is turned to the SEAL position. If you've done this and still hear a loud hissing noise, it may indicate your silicone seal is not fully in place. Press START/STOP to stop cooking, VENT as necessary, and remove the pressure lid. Press down on the silicone ring, ensuring it is fully inserted and lies flat under the ring rack. Once fully installed, you should be able to tug lightly on the ring to rotate it.

The unit is counting up rather than down.

- The cooking cycle is complete and the unit is in Keep Warm mode.

How long does the unit take to depressurize?

- Quick release is about 2 minutes or less. Natural release can take up to 20 minutes or more, depending on the type of food and/or the amount of liquid and food in the pot.

"ADD POT" error message appears on display screen.

- Cooking pot is not inside the cooker base. Cooking pot is required for all functions.

"OTHR LID" error message appears on display screen.

- The incorrect lid is installed for your desired cooking function. Install the pressure lid to use the Pressure, Slow Cook, Yogurt, Steam, or Keep Warm functions.

"SHUT LID" error message appears on display screen.

- The crisping lid is open and needs to be closed for the selected function to start.

"TURN LID" error message appears on display screen.

- The pressure lid is not fully installed. Turn the pressure clockwise until it clicks to use the Pressure, Slow Cook, Yogurt, Steam, and Keep Warm functions.

"OPEN VENT" error message appears on display screen.

- When set to Slow Cook or Sear/Sauté, and the unit senses pressure building up, this message indicates the pressure release valve is in the SEAL position.
- Turn the pressure release valve to the VENT position and leave it there for the remainder of the cooking function.
- If you do not turn the pressure release valve to the VENT position within 5 minutes, the program will cancel and the unit will shut off.

"ADD WATER" error message appears on display screen when using the Steam function.

- The water level is too low. Add more water to the unit for the function to continue.

"ADD WATR" error message appears on display screen when using the Pressure function.

- Add more liquid to the cooking pot before restarting the pressure cook cycle.
- Make sure the pressure release valve is in the SEAL position.
- Make sure the silicone ring is installed correctly.

"ERR" message appears.

- The unit is not functioning properly. Please contact Customer Service at 1-877-646-5288. So we may better assist you, please register your product online at registeryourninja.com and have the product on hand when you call.

Warning

This content is compiled from multiple sources and is provided for reference purposes only. It may not be complete or fully applicable to all situations. If you are unable to resolve your issue, please contact the product manufacturer or an authorized service provider for official support.