

SAFETY INSTRUCTIONS

IMPORTANT SAFEGUARDS

FOR HOUSEHOLD USE ONLY.

WARNING: When using electrical appliances, especially when children are present, basic safety precautions should always be followed to reduce the risk of fire, electric shock, and/or injury to persons, including the following:

1. Read all instructions.
2. This appliance should not be used by children.
3. Extreme caution must be exercised when any appliance is used near children.
4. Do not operate any appliance if the cord or plug is damaged. Do not use this Air Fryer if it malfunctions, is dropped or has been damaged in any way. To avoid the risk of injury or electric shock, never try to repair the Air Fryer yourself. Contact Chefman Customer Service for assistance.
5. To protect against risk of electric shock, do not immerse the cord, plug or Air Fryer in water or any other liquids.
6. Do not use this appliance for purposes other than its intended use.
7. Do not use outdoors or for commercial purposes.
8. The use of accessories or attachments not recommended by Chefman may cause fire, electrical shock or injury, and will result in void of warranty.
9. Do not place on or near a hot gas or electric burner, or heated oven.
10. Only use on a dry, flat, heat resistant surface.
11. The Air Fryer's cord should only be plugged into a 120V AC electrical wall outlet.
12. Do not let the electrical cord hang over the edge of the table or countertop, or touch hot surfaces.
13. Do not leave this appliance unattended during use.
14. This product is not a deep fryer. It is NOT meant to be filled with oil. Never fill the basket or any parts of the Air Fryer with oil. If you choose to use oil, lightly toss food with oil in a separate bowl and then transfer food to the tray inside the basket.
15. When using this appliance, provide adequate ventilation above and on all sides for air circulation. Do not allow this appliance to touch curtains, wall coverings, clothing, dish towels or other flammable materials during use.

16. Caution: This appliance generates heat during use. Proper precautions must be taken to prevent the risk of burns, fire or other damage to persons or property. Keep hands clear of the immediate area surrounding the Air Fryer during operation and use grips and handles on the appliance when operating. Do not put hands or other body parts inside the Air Fryer housing while in use or hot.
17. Use caution when opening the Air Fryer. The inside of the basket and its contents are very hot. Use tongs or protective gloves to remove food from basket.
18. Do not move the Air Fryer while it is in use and/or full of food.
19. Always unplug Air Fryer after use.
20. Never yank cord to disconnect from outlet; instead, grasp the plug and pull firmly.
21. Unplug Air Fryer from outlet before cleaning. Allow to cool completely before cleaning or storing.
22. Never place the Air Fryer in the dishwasher. This product housing cannot be immersed in water and is not dishwasher safe. Only the tray and the basket itself can be submerged in water. The basket and tray are top-rack dishwasher safe.
23. The housing of the Air Fryer can be wiped down between uses with a non-abrasive cleaner.
24. Store Air Fryer in a cool, dry place.
25. Never wrap the cord tightly around the appliance during use or storage; this may cause the wire to fray and break.

WARNING: This appliance has a polarized plug (one blade is wider than the other). To reduce the risk of electric shock, this plug is intended to fit into a polarized outlet only one way. If the plug does not fit fully into the outlet, reverse the plug. If it still does not fit, contact a qualified electrician. Do not attempt to modify the plug in any way

SHORT CORD INSTRUCTIONS

A short power supply cord is provided to reduce the hazards resulting from entanglement or tripping over a longer cord. Longer detachable power-supply cords or extension cords are available and may be used if care is exercised in their use. If a longer detachable power-supply extension cord is used:

1. The marked electrical rating of the cord set or extension cord should be at least as great as the electrical rating of the appliance, and:
2. The cord should be arranged so that it will not drape over the countertop or tabletop where it can be pulled on by children or tripped over unintentionally

LINE CORD SAFETY TIPS

1. Never pull or yank on cord or the appliance.
2. To insert plug, grasp it firmly and guide it into outlet.

3. To disconnect appliance, grasp plug and remove it from outlet.
4. Before each use, inspect the line cord for cuts and/or abrasion marks. If any are found, this indicates that the appliance should be serviced and the line cord replaced. Please contact Chefman Customer Service for assistance.
5. Never wrap the cord tightly around the appliance, as this could place undue stress on the cord where it enters the appliance and cause it to fray and break.

DO NOT OPERATE APPLIANCE IF THE LINE CORD SHOWS ANY DAMAGE OR IF APPLIANCE WORKS INTERMITTENTLY OR STOPS WORKING ENTIRELY.

Features

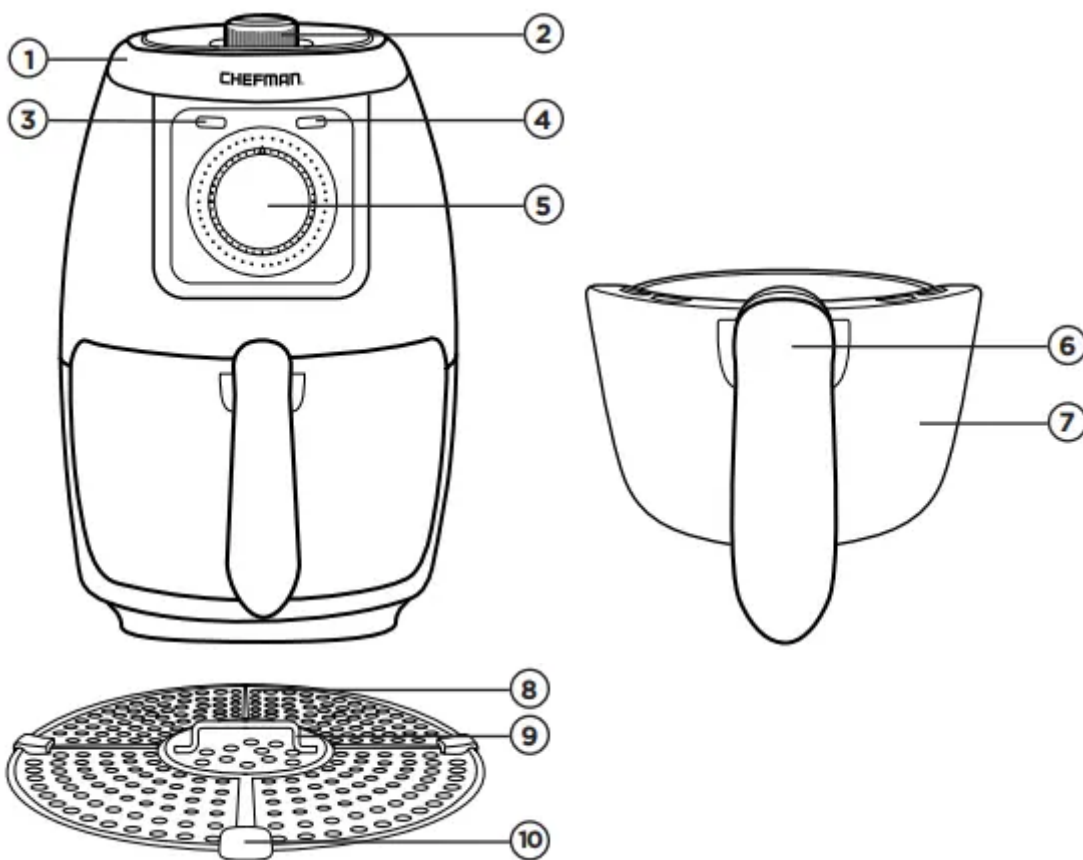

1. AIR FRYER (PICTURED WITH BASKET IN PLACE)
2. TEMPERATURE DIAL (0-400°F)
3. POWER INDICATOR LIGHT
4. HEATING INDICATOR LIGHT
5. TIMER DIAL (0-30 MINUTES)
6. BASKET HANDLE
7. BASKET (1)
8. TRAY (REMOVABLE)
9. TRAY HANDLE
10. RUBBER GRIPS (4, REMOVABLE)

Operating Instructions

BEFORE FIRST USE

Remove all packing materials and stickers from the inside and outside of the Air Fryer. Gently wipe down exterior with a damp cloth or paper towel. Never immerse the Air Fryer or its plug in water or any other liquids.

Pull the basket handle to remove the basket from the Air Fryer. Use the tray handle, in the center of the tray, to remove the tray. Use a sponge and warm, soapy water to wash the inside and outside of the basket and tray. The basket and the tray are top-rack dishwasher safe.

Warning: Do not use abrasive cleaning agents or scouring pads.

Dry thoroughly.

Read all instructions and follow them carefully.

HOW TO USE

1. Prepare the basket and desired food.

Use the tray handle to insert the tray into the basket. Push down to ensure it is secure and in a leveled position. There should be a small amount of space between the tray and bottom of the basket.

Note: Using the Air Fryer with the tray in place allows for maximum amount air circulation, which promotes even cooking and crispiness.

Caution: Never fill the basket with oil. Unlike deep fryers, air fryers require little to no oil to produce crispy results. If you choose to use oil, toss food with oil in a separate bowl and then transfer food to the tray inside the basket.

2. Put food on tray.

Refer to the chart on page 8 for recommended maximum amounts of food, cooking times, temperatures and tips.

3. Put the basket into the Air Fryer.

Use the basket handle to insert the basket into the Air Fryer. Push to close.

4. Plug in the Air Fryer.

Note: The power indicator light will NOT illuminate until the timer is turned past 0.

Note: The Air Fryer will not operate if the basket is not fully pushed into place.

5. Set desired cooking temperature and time.

Adjust the temperature: Turn the temperature dial to the desired temperature between 200°F and 400°F.

Note: The Air Fryer fan operates without heat when the temperature dial is set to approximately 180°F or lower.

Adjust the time: Turn the timer dial to the desired time. Once a time is selected, the Air Fryer will begin to click, indicating the time is counting down.

Note: Maximum cooking time is 30 minutes.

7. Start cooking.

After setting the temperature and time, the power indicator light and the heating indicator light will illuminate and the Air Fryer will begin cooking.

To check food while the Air Fryer is cooking: A) Use the basket handle to pull out the basket.

Note: The power indicator light and the heating indicator light will turn off once the basket is pulled out, but the timer will continue to count down.

B) Use the basket handle to shake and redistribute the food inside the basket (or use tongs to flip food) if necessary, then push the basket back into the unit. The unit will automatically resume cooking when the basket is replaced.

8. Enjoy your air-fried food.

Once the timer completely counts down, the Air Fryer will ding once and turn off.

Use the basket handle to pull out the basket. Use protective gloves and/or tongs to carefully transfer the hot food to a serving plate.

Caution: The basket, tray and contents will be HOT after cooking.

Place the hot basket on a wire rack or trivet to cool.

9. Unplug the Air Fryer and let cool completely before cleaning.

10. Clean the basket and tray after every use.

Cooking Tips

- Almost any food that is traditionally cooked in the oven can be air fried.
- Foods cook best and most evenly when they are of similar size and thickness.
- Smaller pieces of food require less cooking time than larger pieces.
- For best results in the shortest amount of time, air fry food in small batches. Avoid stacking or layering when possible.
- Most prepackaged foods do not need to be tossed in oil before air frying. Most already contain oil and other ingredients that enhance browning and crispiness.

- Frozen appetizers and hors d'oeuvres air fry very well. For best results, arrange them on the tray in a single layer.
- If layering foods, be sure to shake the basket halfway through (or flip food) to promote even cooking.
- Toss foods you are preparing from scratch, such as French fries or other vegetables, with a small amount of oil to promote browning and crispiness.
- When air frying fresh vegetables, make sure to pat them dry completely before tossing with oil and air frying to ensure maximum crispiness.
- When air frying battered food, stick to thick, pasty batters. Thin batters, such as the batters used to make tempura, will run and not set fast enough like they do in a deep fryer.
- Coating battered foods in panko (Japanese-style breadcrumbs) or puffed rice, and then spraying them with oil, helps create crispy, healthier versions of your favorite fried foods.
- Air fryers are great for reheating food, including pizza. To reheat your food, set the temperature to 300°F for up to 10 minutes. Use a thermometer to ensure reheated foods reach food safe temperatures.

The temperatures and times recommended below are based off of the listed recommended amounts and weights. If using a smaller amount or weight, check food sooner than the recommended time because it will likely cook faster.

Ingredient	Amount	Time (mins)	Temp (°F)	Shake	Cooking Tip
Bacon	2 slices (cut in half)	6 (chewy) 8 (crispy)	400	No	After cooking, use tongs to transfer bacon to a paper-towel lined plate.
Chicken Breast (Thick, about 8 oz)	2 pieces	20-25	375	Yes	Brush with oil, season with salt and desired spices.
Chicken Breast (Thin, about 3 oz)	2 pieces	6-8	400	No	Brush with oil, season with salt and desired spices.
Chicken Drumsticks/Thighs	2 pieces	16-18	400	No	Season with salt and desired spices.
Chicken Nuggets (Frozen)	8 pieces	10	400	No	
Chicken Wings (Flats and drumettes separated)	7 pieces (about 12 oz total)	18-20	400	Yes	Season with salt; enjoy as is or, when done, toss in favorite chicken wing sauce.
Fish Fingers (Frozen)	10 pieces	7	400	No	
French Fries (Frozen/Thin)	12 oz	16-18	400	Yes	
French Fries (Frozen/Thick)	1 lb	16-18	400	Yes	
French Fries (Homemade cut into 1/4- x 1/4-inch pieces)	1 lb	20	400	Yes	Rinse with cold water, pat dry, toss with 1 tbsp olive oil, season with salt and desired spices; use tongs to toss during cooking.
Hamburgers (Thin, 4 oz each)	1 patty	12 (medium)	375	Yes	Brush with oil, season with salt and desired spices such as freshly ground black pepper and garlic powder.
Mozarella Sticks (Frozen)	8 pieces	6	400	Yes	
Pork Chops (Bone-in, about 8 oz)	1 piece	12 (medium)	400	Yes	Season with salt and desired spices.
Pork Chops (Boneless, about 3 oz)	3 pieces	8	400	Yes	Season with salt and desired spices.
Steak (10 oz)	1 piece	12 (medium)	400	Yes	Season with salt and desired spices.
Salmon (1 inch wide, 4.5 oz)	3 pieces	10 (medium)	400	No	Brush skin with oil and place on tray skin-side down. Season with salt and desired spices.
Shrimp (Large)	1 lb	10-12	400	Yes	Pat dry, toss with 1/2 tbsp olive oil, season with salt and desired spices; shake often.

Note: This table is only a guide and does not contain exact recipes.

Note: Use extreme caution while handling hot food in fryer basket. Excess oil will drip into basket when preparing greasy foods. Empty basket after every use.



Troubleshooting Guide

Problem	Possible Cause	Solution
The Air Fryer is not working/will not turn on.	<ol style="list-style-type: none">1. Air Fryer is not properly plugged in.2. The timer has not been turned past 0.3. The basket is not fully pushed into place.	<ol style="list-style-type: none">1. Ensure that the plug is properly secured in wall outlet.2. Turn the timer dial past 0 to initiate cooking.3. Use the basket handle to push basket firmly into Air Fryer's housing.
There is smoke coming out of the Air Fryer.	<ol style="list-style-type: none">1. Air Fryer is being used for the first time.2. There is either too much grease in or on the food being air fried.3. There is leftover grease in the basket.	<ol style="list-style-type: none">1. Smoke will subside after first use.2. Lightly coat food with oil.3. Clean the basket after every use.
Air fried foods are not crispy	<ol style="list-style-type: none">1. The food didn't have enough oil.2. The food was coated in too much oil and became soggy.	Only toss oil-free fresh foods in a small amount of oil to achieve the maximum crispiness.

Cleaning & Maintenance

- Ensure the Air Fryer is unplugged and cool before cleaning.
- Once the Air Fryer and basket are cool, remove the basket from the Air Fryer (if it is not already removed). Use the tray handle to remove tray. Use a sponge and warm, soapy water to wash the inside and outside of the basket and tray. Warning: Do not use abrasive cleaning agents or scouring pads.
- The basket and the tray are top-rack dishwasher safe.
- Gently wipe down exterior with a damp cloth or paper towel.
- Never immerse the Air Fryer or its plug in water or any other liquid.
- Dry all parts thoroughly before storage.
- Store the Air Fryer in a cool, dry place.

Warning

This content is compiled from multiple sources and is provided for reference purposes only. It may not be complete or fully applicable to all situations. If you are unable to resolve your issue, please contact the product manufacturer or an authorized service provider for official support.

Document generated by [ManualsFile](#)