

Assembly



Read entire operator's manual before you attempt to assemble or operate your new pressure washer.

Your pressure washer requires some assembly and is ready for use after it has been properly serviced with the recommended oil and fuel.

If you have any problems with the assembly of your pressure washer, please call the pressure washer helpline at (888) 331-4569. If calling for assistance, please have the model, revision, and serial number from the identification label available.

Unpack Pressure Washer

1. Remove the parts bag, accessories, and inserts included with pressure washer.
2. Open carton completely by cutting each corner from top to bottom,
3. Ensure you have all included items prior to assembly, items in the carton include:

Items in the carton include

- Main Unit
- Handle
- High Pressure Hose
- Spray Gun
- Nozzle Extension with Quick Connect Fitting
- Plastic Accessory Tray
- Hose Hook Wireform
- Oil Pouch
- Parts bag (which includes the following):
- Operator's Manual
- Bag of 4 Multi-Colored Quick Connect Spray Tips
- Rubber Strap
- Hardware Kit (which includes):
- Carriage Bolts (2)
- Plastic Knobs (2)
- Tree Clips (4)

- Rope Guide
- Plastic Knob

Attach Handle and Accessory Tray

1. Place handle (A) onto handle supports connected to mam unit. Make sure holes in handle align with holes on handle supports.

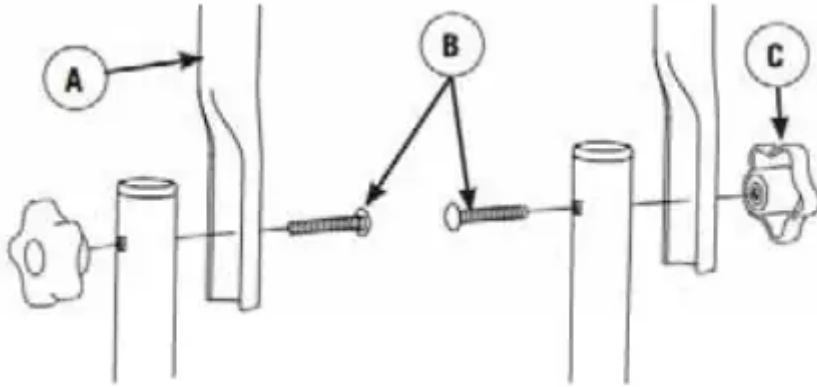

2. Insert carriage bolts (B) through holes from inside of unit and attach a plastic knob (C) from outside of unit. Tighten by hand.

3. Place accessory tray (D) over holes (E) on handle (viewing from front of unit). Push tree clips (F) into the holes until they sit flat against the accessory tray.

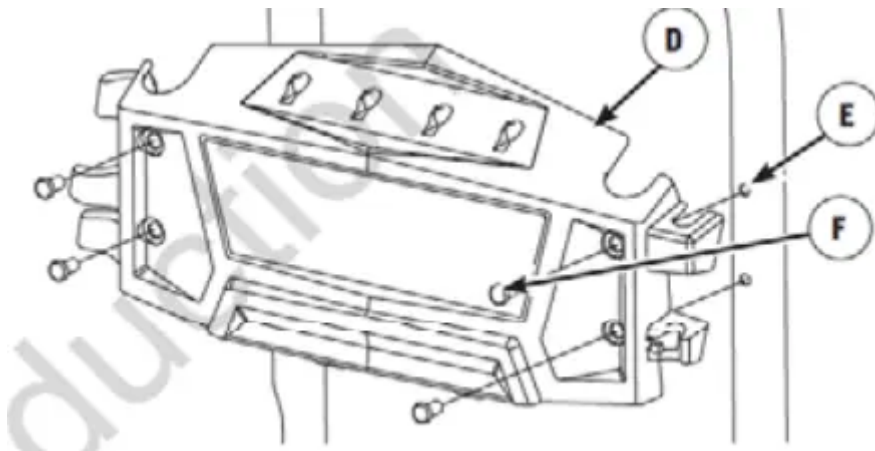

4. Attach rope guide (G) through handle with plastic knob (H). Tighten by hand. Route engine recoil rope through guide.

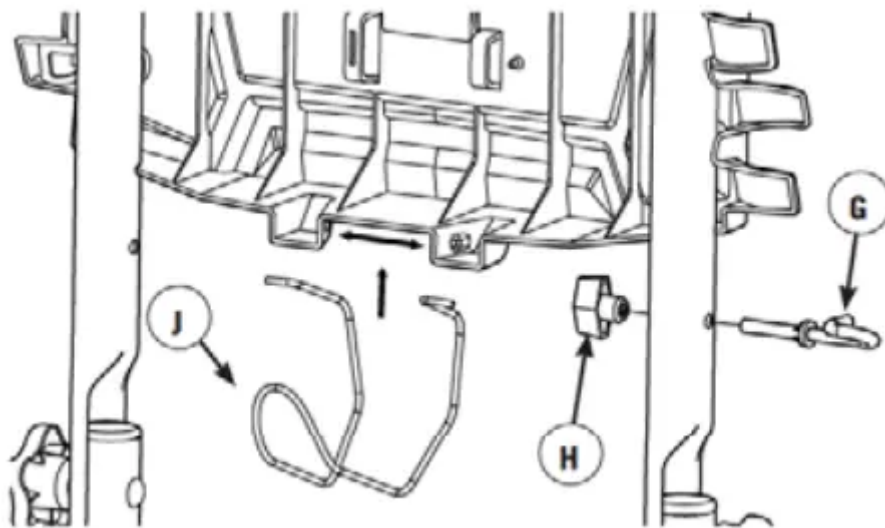

5. Squeeze hose hook wireform (J) together and insert into grooves at bottom of accessory tray.

Add Engine Oil and fuel

- Place pressure washer on a level surface.
- Refer to engine operator's manual and follow oil and fuel recommendations and instructions.

NOTICE Any attempt to crank or start the engine before it has been properly filled with the recommended oil will result in equipment failure.

- Refer to engine manual for oil and fuel fill information.
- Damage to equipment resulting from failure to follow this instruction will void warranty.

NOTICE Check oil often during engine break-in. Refer to engine operator's manual for recommendations.

Lubricate O-Rings

Lubrication of c-rings is extremely important for installation and operation. The use of a lubricant (petroleum or synthetic grease) during assembly helps seat o-rings properly and provides an improved seal. It also helps protect the o ring from damage by abrasion, pinching or cutting and extends the life of the o-ring.

NOTICE ALWAYS apply a small amount of lubricant on o-rings prior to assembling the garden hose to the pump (A), high pressure hose (B), spray gun (C), and nozzle extension (D).

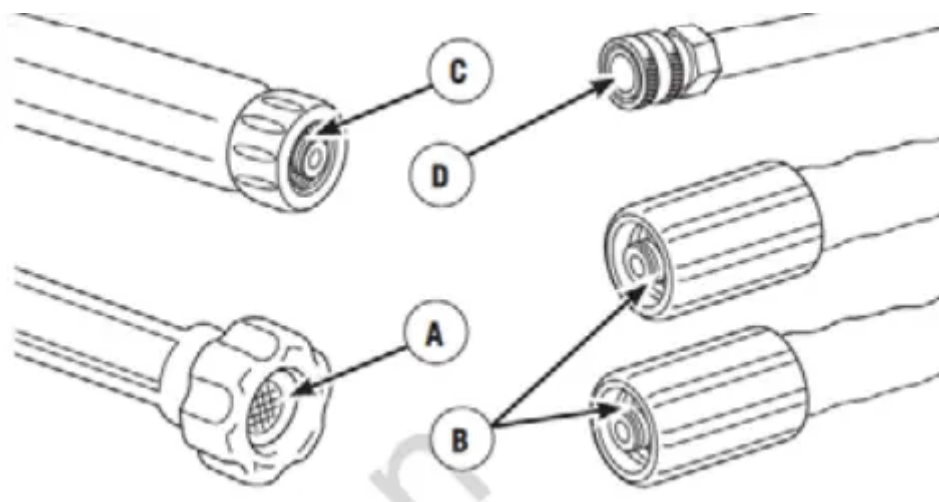

Lubricate all connections shown, following these instructions:

1. Inspect and clean connecting surfaces prior to lubrication and assembly.
2. Use lubricants sparingly during assembly; a light film is all that is required.
3. Use a small brush or cotton swab to apply grease directly to o-rings where they are not accessible (QC fitting, M22 fitting).

Connect Hose and Water Supply to Pump

NOTICE DC NUT run the pump without the water supply connected and turned on.

- Damage to equipment resulting from failure to follow this instruction will void warranty.
1. Uncoil high pressure hose and attach one end of hose to base of spray gun. Tighten by hand.

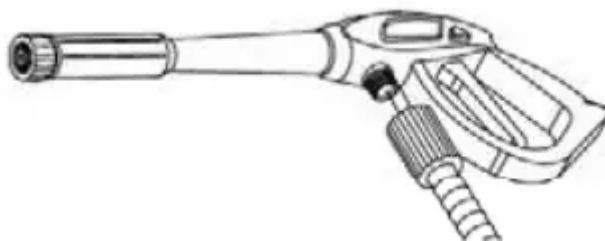

WARNING The high pressure stream of water that this equipment produces could cut through skin and its underlying tissues, resulting in serious injury and possible amputation.

- NEVER connect high pressure hose to nozzle extension.
 - Keep high pressure hose connected to pump and spray gun while system is pressurized.
 - Always be certain spray gun, nozzles and accessories are correctly attached.
2. Attach other end of high pressure hose to high pressure outlet on pump. Tighten by hand.

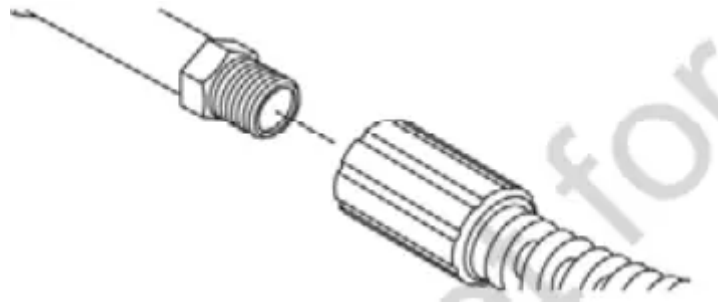

3. Run water through your garden hose for 30 seconds to clean out any debris.

NOTICE DO NOT siphon standing water for the water supply. Use ONLY cold water (less than 100°F (38°C)).

4. Before connecting garden hose to water inlet, inspect inlet screen (A). Clean screen if it contains debris or have it replaced if damaged. DO NOT run pressure washer if inlet screen is damaged.

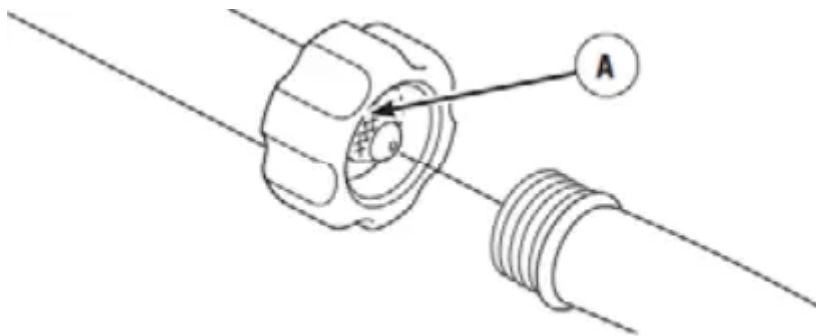

NOTICE Using a One Way Valve (vacuum breaker or check valve) at pump inlet could cause pump or inlet connector damage.

NOTICE Using a One Way Valve (vacuum breaker or check valve) at pump inlet could cause pump or inlet connector damage.

- There MUST be at least 10 ft. (3 m) of unrestricted garden hose between the pressure washer inlet and any device, such as a vacuum breaker or check valve.
- Damage to equipment resulting from failure to follow this instruction will void warranty.

5. Connect the garden hose (not to exceed 50 ft. (15 m) in length) to the water inlet. Tighten by hand.

WARNING Risk of eye injury. Spray could splash back or propel objects resulting in serious injury.

- Always wear indirect vented (chemical splash) safety goggles marked to comply with ANSI Z87.1 when using or in vicinity of this equipment.
- NEVER substitute safety glasses or dry-condition goggles for indirect vented safety goggles.

6. Turn ON the water, press red button (B) on the gun and squeeze the trigger to purge the pump system of air and impurities.

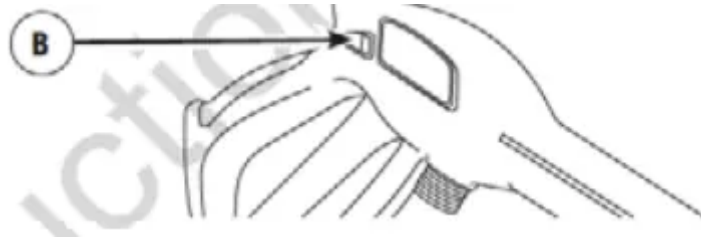

Checklist Before Starting Engine

Review the unit's assembly to ensure you have performed all of the following.

1. Be sure to read Operator Safety and Operation before using pressure washer.
2. Make sure handle is in place and secure.
3. Check that oil has been added to proper level in the engine crankcase.
4. Add proper fuel to fuel tank.
5. Check for properly tightened hose connections.
6. Check to make sure there are no kinks, cuts, or damage to high pressure hose.
7. Provide a proper water supply at an adequate flow.

Features and Controls



Read this Operator's Manual and safety rules before opening your pressure washer. Compare the illustrations with your pressure washer, to familiarize yourself with the locations of various controls and adjustments. Save this manual for future reference.

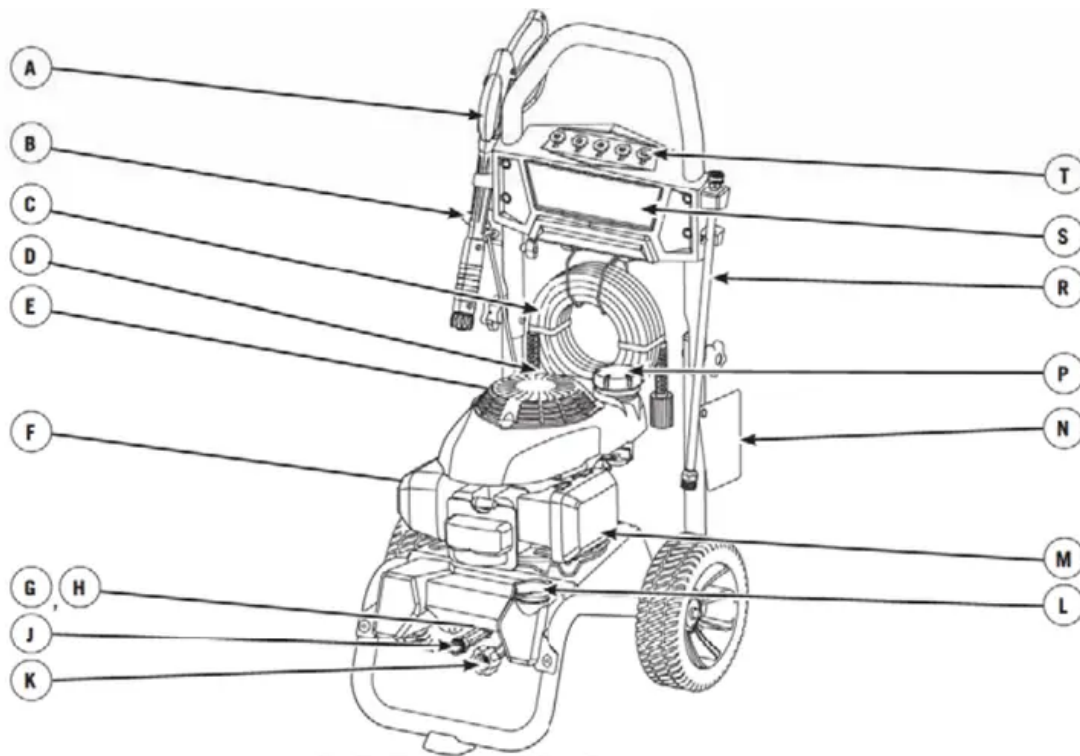

- A - Spray Gun — Controls the application of water onto cleaning surface with trigger device. Includes trigger lock.
- B - Recoil Starter — Used for starting the engine manually.
- C - High Pressure Hose — Connect one end to water pump and the other end to spray gun.
- D - Oil Fill/Dipstick — Check and fill with oil here.
- E - Identification Label — Provides model and serial number of pressure washer. Please have these readily available if calling for assistance.
- F - Engine Identification — Provides model, type and code of engine. Please have these readily available if calling for assistance.
- G - Pump — Develops high pressure.
- H - Automatic Cool Down System — Cycles water through pump when water reaches above 125°F (51aC). Warm water will discharge from pump onto ground. This system prevents internal pump damage,
- J - High Pressure Outlet — Connection tor high pressure hose.
- K - Water Inlet — Connection for garden hose.
- L - Detergent Tank — Lso to hold up to one half gallon (1.9 l) of pressure washer detergent.
- M - Air Filter — Protects engine by filtering dust and debris Out of intake air.
- N - Warning/flperating Instructions Tag — Identifies hazards and proper procedure to start/stop pressure washer.

- P - Fuel Tank — Fill tank with regular unleaded fuel. Always leave room for fuel expansion.
- R - Nozzle Extension with Quick Connect — Allows you to switch between five different spray tips.
- S - Accessory Tray — Provides convenient storage for standard and optional accessories, such as brushes, turbo wands, etc.
- T - Spray Tips — Jet soap. Jet flush, 0*, 25° and 40*: for various high pressure cleaning applications.

Items Not Shown:

Engine Controls — See engine manual for details on engine controls.

Operation

If you have any problems operating your pressure washer, please call the pressure washer helpline at (888) 331-4569.

Pressure Washer Location

Carbon Monoxide Poisoning

WARNING POISONOUS GAS HAZARD. Engine exhaust contains carbon monoxide, a poisonous gas that could kill you in minutes. You CANNOT smell it, see it, or taste it. Even if you do not smell exhaust fumes, you could still be exposed to carbon monoxide gas.

- Operate this product ONLY outside far away from windows, doors and vents to reduce the risk of carbon monoxide gas from accumulating and potentially being drawn towards occupied spaces.
- Install battery-operated carbon monoxide alarms or plug-in carbon monoxide alarms with battery back-up according to the manufacturer's instructions. Smoke alarms cannot detect carbon monoxide gas.
- DO NOT run this product inside homes, garages, basements, crawlspaces, sheds, or other partially-enclosed spaces even if using fans or opening doors and windows for ventilation. Carbon monoxide can quickly build up in these spaces and can linger for hours, even after this product has shut off.
- ALWAYS place this product downwind and point the engine exhaust away from occupied spaces.

If you start to feel sick, dizzy, or weak while using this product. get to fresh air RIGHT AWAY. See a doctor. You may have carbon monoxide poisoning.

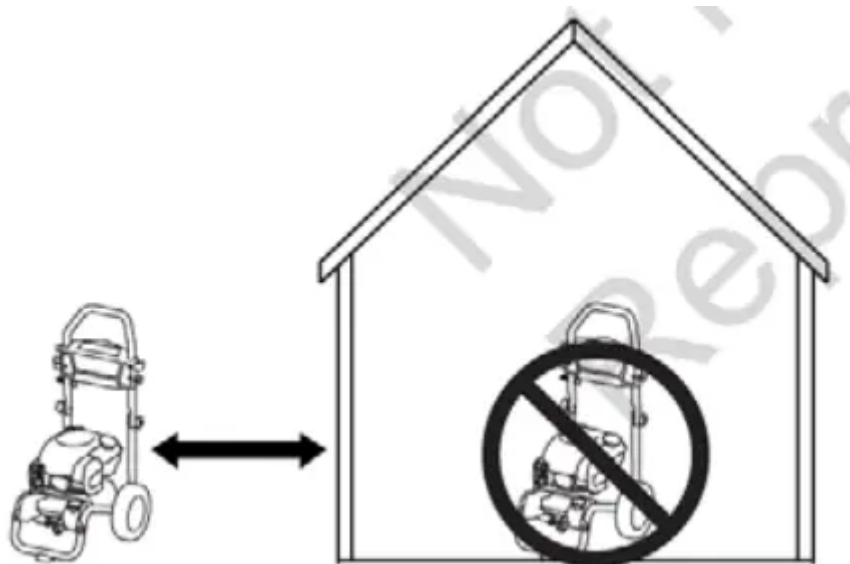

Risk of Fire Clearances

WARNING Exhaust heat/gases could ignite combustibles, structures or damage fuel tank causing a fire, resulting in death or serious injury.

- Keep at least 5 ft. (1.5 m) clearance on all sides of pressure washer including overhead.

How to Start Your Pressure Washer

To start your pressure washer for the first time, follow these instructions step by step. This starting information also applies if you have let the pressure washer sit idle for at least a day.

1. Place pressure washer near an outside water source capable of supplying water at a flow rate greater than 3.4 gallons (12.37 l) per minute and no less than 20 PSI (1.3 BAR) at pressure washer end of garden hose. DO NOT siphon supply water.
2. Check that high pressure hose is tightly connected to spray gun and pump. See Assembly section.
3. Make sure unit is in a level position.
4. Connect garden hose to water inlet on pressure washer pump,

NOTICE DO NOT run the pump without the water supply Connected and turned on.

- Damage to equipment resulting from failure to follow this instruction will void warranty.
5. Turn ON water, point gun in a safe direction, press red button and squeeze trigger to purge pump system of air and impurities.
 6. Attach nozzle extension to spray gun. Tighten by hand.

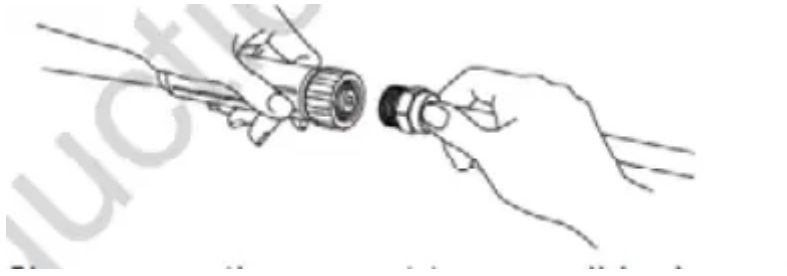

7. Choose spray tip you want to use, pull back on collar of nozzle extension, insert spray tip and release collar. Tug on spray tip to make sure it is securely in place. See How to Use Spray Tips.

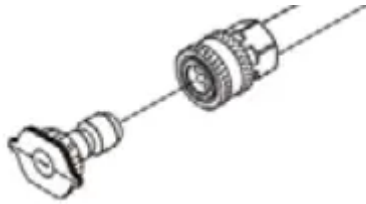

NOTICE Before starting the pressure washer, be sure you are wearing safety goggles as described.

WARNING Risk of eye injury. Spray could splash back or propel objects resulting in serious injury.

- Always wear indirect vented (chemical splash) safety goggles marked to comply with ANSI Z87.1 when using or in vicinity of this equipment.
- NEVER substitute safety glasses or dry-condition goggles for indirect-vented safety goggles.

8. When starting engine, position yourself as recommended and start engine according to instructions given in engine operator's manual. Also see operating instructions tag located on the pressure washer.



WARNING Starter cord kickback (rapid retraction)

A will pull hand and arm toward engine faster than you can let go which could cause broken i bones, fractures, bruises, or sprains resulting in serious injury.

- NEVER pull starter cord without first relieving spray gun pressure.
- When starting engine, pull cord slowly until resistance is felt and then pull rapidly to avoid kickback,
- After each starting attempt, where engine fails to run always point spray gun in safe direction, press red button and squeeze spray gun trigger to release high pressure.
- Firmly grasp spray gun with both hands when using high pressure spray to avoid injury when spray gun kicks back.

9. Return starter grip handle slowly. DO NOT let rope "snap back" against starter.

WARNING The high pressure stream of water that this equipment produces could cut through skin and its underlying tissues, resulting in serious injury and possible amputation. Spray gun traps high water pressure, even when engine is stopped and water is disconnected, which could result in serious injury.

- DO NOT allow CHILDREN to operate pressure washer.
- Keep high pressure hose connected to pump and spray gun while system is pressurised.
- NEVER aim spray gun at people, animals, or plants.
- DO NOT secure spray gun in open position.
- DO NOT leave spray gun unattended while machine is running.

- NEVER use a spray gun which does not have a trigger lock or trigger guard in place and in working order.
- Always be certain spray gun, nozzles and accessories are correctly attached.

WARNING Exhaust heat/gases could ignite flammable combustibles, structures or damage fuel /A tank causing a fire, resulting in death or serious injury. Contact with muffler area could cause burns resulting in serious injury.

- DO NOT touch hot parts and AVOID hot exhaust gases,
- Allow equipment to cool before touching.
- Keep at least 6 ft. (1.5 m) of clearance on all sides of pressure washer me I ini mg overhead.
- It is a violation of California Public Resource Code, Section 4442, to use or operate the engine on any forest-covered, brush-covered, or grass-covered land unless the exhaust system is equipped with a spark arrester, as defined in Section 4442, maintained in effective working order. Other states or federal jurisdictions may have similar laws. Contact the original equipment manufacturer, retailer, or dealer to obtain a spark arrester designed for the exhaust system installed on this engine.
- Replacement parts must be the same and installed in the same position as the original parts.

How to Stop Your Pressure Washer

1. Release spray gun trigger and let engine idle for two minutes.
2. Turn engine off according to instructions given in engine operator's manual.
3. ALWAYS point gun in a safe direction and press red button and squeeze spray gun trigger to release retained high water pressure.

WARNING The high pressure stream of water that this equipment produces could cut through skin and its underlying tissues, resulting in serious injury and possible amputation. Spray gun traps high water pressure, even when engine is stopped and water is disconnected, which could result in serious injury.

- Keep high pressure hose connected to pump and spray gun while system is pressurized.
- ALWAYS point spray gun in safe direction, press red button and squeeze spray gun trigger to release high pressure, every time you stop engine.

How to Use Accessory Tray

The unit is equipped with an accessory tray with places to store your spray gun, nozzle extension, high pressure hose and quick connect spray tips.

1. Place nozzle extension in slots on left side of accessory tray (viewing from rear of unit) and snap in.

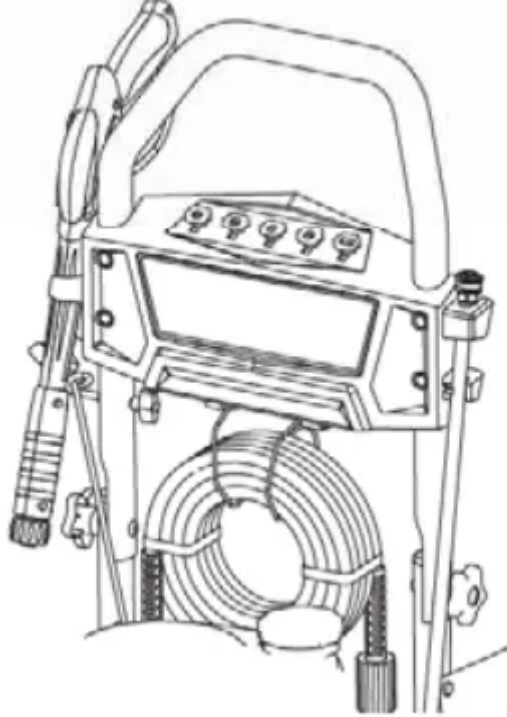

2. Place spray gun through grooves on right side of accessory tray.
3. Insert multi-colored spray tips in holes provided on front of accessory tray.
4. Wrap high pressure hose and hang on hook of accessory tray.

NOTICE There is also a slot for storing a can of Pump Saver on the back. See Pump Saver Storage.

How to Use Spray Tips

The quick-connect on the nozzle extension allows you to switch between five different quick connect spray tips. Spray tips can be changed while pressure washer is running once spray gun trigger lock is engaged. The spray tips vary the spray pattern as shown.

Follow these instructions to change spray tips:

1. Pull back collar on quick-connect and pull current spray tip off. Store spray tips in holes provided on the accessory tray.

WARNING The high pressure stream of water that this equipment produces could cut through skin and its underlying tissues, resulting in serious injury and possible amputation.

- NEVER exchange spray tips without the trigger lock being engaged on the spray gun.

- DO NOT twist spray tips while spraying.
2. Select desired spray tip:
- For delicate rinse, for gentle cleaning of cars/ trucks, boats, RV's, patio furniture, lawn equipment, etc., select white 40° spray tip.
 - For general rinsing, ideal for most all purpose cleaning such as home siding, brick patios, wood decks, driveways and sidewalks, garage floors, etc., select yellow 15° spray tip.
 - For maximum rinsing, for stubborn or hard to reach surface such as second story surfaces, paint removal, oil stains, rust removal or other stubborn *поль* substances (tar, gum, grease, wax, etc.), select red 0° spray tip.
 - Select cyan jet flush spray tip for quick high flow clean up and long reach cleaning of second story siding and windows.
 - Select magenta jet soap spray tip for general soap applications or to launch soap to second story siding and windows.
3. Pull back on collar, insert new spray tip and release collar. Tug on spray tip to make sure it is securely in place.

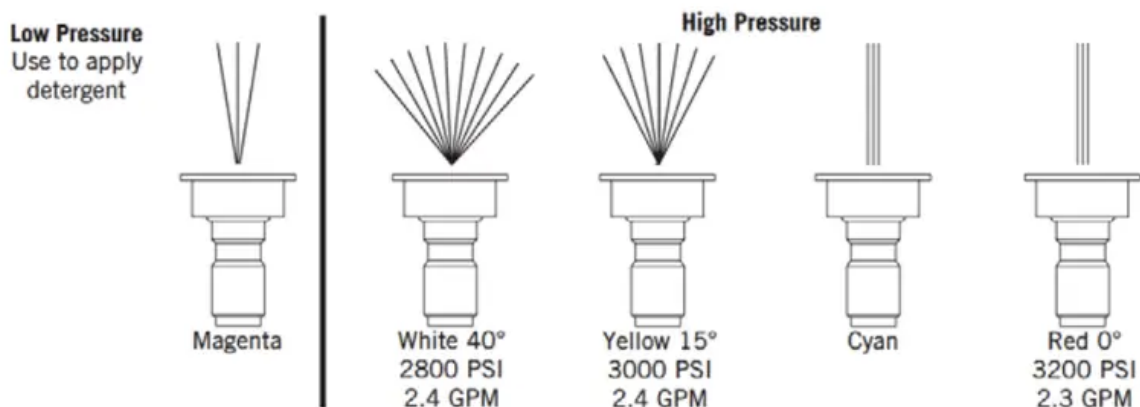

Usage Tips

- * For most effective cleaning, keep spray tip from 8 to 24 in. away from cleaning surface.
- * If you get spray tip too close, especially using a high pressure spray tip, you may damage surface being cleaned.
- * DO NOT get closer than 6 in, when cleaning tires.

Applying Detergent

WARNING Chemical Burn Hazard. Chemicals could cause burns resulting in death or serious injury.

- * DO NOT use caustic liquid with pressure washer.
- * Use ONLY pressure washer safe detergents/soaps. Follow all manufacturers instructions.

To apply detergent, follow these steps:

1. Review use of spray tips.
2. Prepare detergent solution as required by job.
3. Pour detergent into cleaning tank.

NOTICE The cleaning tank holds 0.5 gallons (1.9 liters).

4. Make sure magneta spray tip is installed.

NOTICE Detergent cannot be applied with the high pressure spray tips (White, Yellow, Cyan or Red).

5. Make sure garden hose is connected to water inlet. Check that high pressure hose is connected to spray gun and pump. Turn on water.

NOTICE You must attach all hoses before you start the engine.

- Starting the engine without all the hoses connected and without the water turned ON could damage the pump.
- Damage to equipment resulting from failure to follow this instruction will void warranty.

6. Start engine following instructions How to Start Your Pressure Washer.

7. Apply detergent to a dry surface, starting at lower portion of area to be washed and work upward, using long, even, overlapping strokes

8. Allow detergent to "soak in" for 3-5 minutes before washing and rinsing. Reapply as needed to prevent surface from drying. Do NOT allow detergent to dry on (prevents streaking).

Pressure Washer Rinsing

For Rinsing:

1. Remove magneta detergent spray tip from nozzle extension.
2. Select and install desired high pressure spray tip following instructions
3. Keep the spray gun a safe distance from the area you plan to spray.

WARNING Kick back from spray gun could cause you to fall resulting in death or serious injury.

- Operate pressure washer from a stable surface.
- Be extremely careful if you must use the pressure washer from a ladder, scaffolding, or any other similar location.
- Firmly grasp spray gun with both hands when using high pressure spray to avoid injury when spray gun kicks back.

4. Apply a high pressure spray to a small area, then check the surface for damage. If no damage is found, it is okay to continue cleaning.

5. Start at the top of the area to be rinsed, working down with same overlapping strokes as you used for washing and applying detergent.

Automatic Cool Down System (Thermal Relief)

If you run the engine on your pressure washer for 3-5 minutes without pressing the trigger on the spray gun, circulating water in the pump can reach temperatures above 125°-155°F (51°-68°C). The system engages to cool the pump by discharging the warm water onto the ground.

Maintenance

General Recommendations

Regular maintenance will improve the performance and extend the life of the pressure washer. See any qualified dealer for service.

The pressure washer's warranty does not cover items that have been subjected to operator abuse or negligence. To receive full value from the warranty, the operator must maintain the pressure washer as instructed in this manual, including proper storage as detailed in Winter Storage and Long term Storage.

NOTICE Should you have questions about replacing components on your pressure washer, please call (888) 331-4569 for assistance.

Some adjustments will need to be made periodically to properly maintain your pressure washer.

* Some adjustments will need to be made periodically to properly maintain your pressure washer. Check the spray gun and nozzle extension assembly for wear.

* All maintenance in this manual and the engine operator's manual should be made at least once each season.

* Once a year you should clean or replace the spark plug, clean or replace the air filter. A new spark plug and clean air filter assure proper fuel-air mixture and help your engine run better and last longer. Please refer to your engine operator's manual for more details.

Before Each Use

1. Check engine oil level.
2. Clean debris.
3. Check water inlet screen for damage.
4. Check high pressure hose for leaks.
5. Check detergent tube/tank for damage.

6. Check spray gun and nozzle extension assembly for leaks.

7. Rinse out garden hose to flush out debris.

Pump Oil

DO NOT attempt any oil maintenance on this pump. The pump is pre-lubricated and sealed from the factory, requiring no additional maintenance for the life of the pump.

Pressure Washer Maintenance

Clean Debris

Daily or before use. clean accumulated debris from pressure washer. Keep linkage. spring and controls clean.

Keep area around and behind muffler free from any combustible debris. Inspect cooling air slots and openings on the pressure washer. These openings must be kept clean and unobstructed.

Pressure washer parts should be kept clean to reduce the risk of overheating and ignition of accumulated debris.

- Use a damp cloth to wipe exterior surfaces clean.

NOTICE Improper treatment of pressure washer could damage it and shorten its life.

- DO NOT insert any objects through cooling slots.
- Use a soft bristle brush to loosen caked on dirt. oil. etc.
- Use a vacuum cleaner to pick up loose dirt and debris.

Check and Clean Inlet Screen

Examine the screen on the pump's water inlet. Clean it if the screen is clogged or replace it if screen is damaged.

Check High Pressure Hose

The high pressure hose can develop leaks from wear. kinking. or abuse. Inspect the hose each time before using it. Check for cuts. leaks. abrasions or bulging of cover. damage or movement of couplings. If any of these conditions exist. replace the hose immediately.

WARNING The high pressure stream of water that this equipment produces could cut through skin and its underlying tissues. resulting in serious injury and possible amputation.

- NEVER repair high pressure hose. Replace it.
- Replacement hose rating MUST equal or exceed maximum pressure rating of unit.

Check Detergent Tube/Tank

Examine detergent tank and detergent tube and clean if clogged. The tube should fit tightly on the barbed fitting of the pump and tank. Examine the tube for leaks or tears.

Replace the tank or tube if either is damaged.

Detergent Siphoning Check Ball

Occasionally check ball in detergent siphoning system may become stuck from storage. dried soap. or minerals in water. The check ball can be freed by performing the following:

NOTICE Before performing this procedure. be sure you are wearing safety goggles as described.

WARNING Risk of eye injury.

Spray could splash back or propel objects resulting in serious injury.

- Always wear indirect vented (chemical splash) safety goggles marked to comply with ANSI Z87.1 when using or in vicinity of this equipment.
- NEVER substitute safety glasses or dry-condition goggles for indirect vented safety goggles.

1. Shut OFF engine and turn off water supply.
2. ALWAYS point spray gun in a safe direction, press red button and squeeze spray gun trigger to release retained high water pressure.

WARNING The high pressure stream of water that this equipment produces could cut through skin and its underlying tissues, resulting in serious injury and possible amputation. Spray gun traps high water pressure, even when engine is stopped and water is disconnected, which could result in serious injury.

- Keep high pressure hose connected to pump and spray gun white system is pressurized.
 - ALWAYS point spray gun in safe direction, press red button and squeeze spray gun trigger to release high pressure, every time you stop engine.
3. Remove detergent hose from barbed fitting on pump.
 4. Using a firm, blunt object 7/54" in diameter or smaller, by at least 1" long, such as an Allen wrench, slowly insert the object into the barbed fitting until you meet resistance. This resistance is the check ball.
 5. Slowly push down until you feel the ball move slightly, push no more than 1/8". Slight pressure may be required to free the ball.
 6. Repeat steps 4 and 5 if necessary.
 7. Reinstall detergent hose onto barb fitting.
 8. Treat with Pump Saver as described in Protecting the Pump during storage to prevent reoccurrence.

Check Spray Gun

Examine the hose connection to the spray gun and make sure it is secure. Test the trigger by pressing the red button and making sure the trigger "springs back" into place when you release it.

You should not be able to press the trigger without pressing the red button. Replace spray gun immediately if it fails any of these tests.

Spray Tip Maintenance

A pulsing sensation felt while squeezing the spray gun trigger may be caused by excessive pump pressure. The principal cause of excessive pump pressure is a spray tip clogged or restricted with foreign materials, such as dirt, etc. To correct the problem, immediately clean the spray tip following these instructions:

1. Shut OFF engine and turn off water supply.
2. ALWAYS point spray gun in a safe direction, press red button and squeeze spray gun trigger to release retained high water pressure._

WARNING The high pressure stream of water that this equipment produces could cut through skin and its underlying tissues, resulting in serious injury and possible amputation. Spray gun traps high water pressure, even when engine is stopped and water is disconnected, which could result in serious injury.

- Keep high pressure hose connected to pump and spray gun while system is pressurized.
- ALWAYS point spray gun in safe direction, press red button and squeeze spray gun trigger to release high pressure, every time you stop engine.

3. Remove spray tip from end of nozzle extension.
4. Use a small paper clip to free any foreign material clogging or restricting spray tip (A).

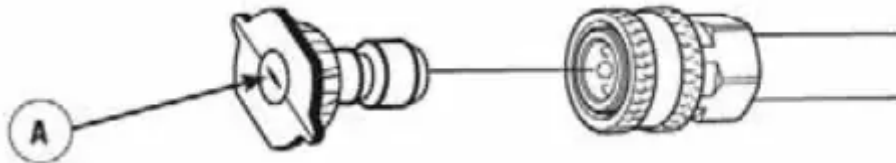

5. Remove nozzle extension from spray gun.
6. Using a garden hose, remove additional debris by back flushing water through nozzle extension. Back flush between 30 to 60 seconds.

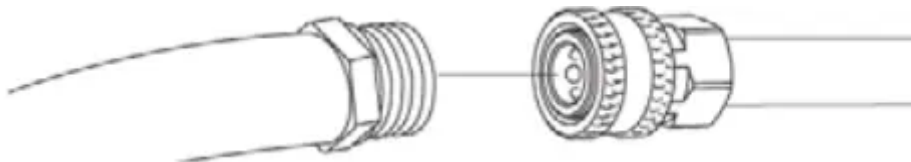

7. Reinstall spray tip into nozzle extension.
8. Reconnect nozzle extension to spray gun.
9. Make sure garden hose is connected to wafer inlet. Check that high pressure hose is connected to spray gun and pump. Turn on water.
10. Start engine following instructions *How to Start Your Pressure Washer*.

11. Test pressure washer by operating with each quick connect spray tip.

O-Ring Maintenance

Purchase an O-Ring/Maintenance Kit, model 705001, by contacting the nearest authorized service center. It is not included with the pressure washer. This kit includes replacement o rings, rubber washer and water inlet filter. Refer to the instruction sheet provided in the kit to service your unit's o-rings.

WARNING The high pressure stream of water that this equipment produces could cut through skin and its underlying tissues, resulting in serious injury and possible amputation

- NEVER repair leaking connections with sealant of any kind. Replace o-ring or seal.

Engine Maintenance

See the engine operator's manual for instructions on how to properly maintain the engine.

CAUTION Avoid prolonged or repeated skin contact with used motor oil,

- Used motor oil has been shown to cause skin cancer in certain laboratory animals.
- Thoroughly wash exposed areas with soap and water.

KEEP OIL OUT OF REACH OF CHILDREN, DON'T POLLUTE. CONSERVE RESOURCES, RETURN USED OIL TO COLLECTION CENTERS.

After Each Use

Water should not remain in the unit for long periods of time. Sediments or minerals can deposit on pump parts and freeze pump action. Follow these procedures after every use:

1. Shut OFF engine, turn off water supply, point gun in a safe direction, press red button and squeeze trigger to relieve trapped pressure, and let engine cool.

WARNING The high pressure stream of water that this equipment produces could cut through skin and its underlying tissues, resulting in serious injury and possible amputation. Spray gun traps high water pressure, even when engine is stopped and water is disconnected, which could result in serious injury.

- Keep high pressure hose connected to pump and spray gun while system is pressurized.
 - ALWAYS point spray gun in safe direction, press red button and squeeze spray gun trigger to release high pressure, every time you stop engine.
2. Disconnect hose from spray gun and high pressure outlet on pump. Drain water from hose, gun, and nozzle extension. Use a rag to wipe off the hose.
 3. Place the spray gun, nozzle extension, and spray tips in the accessory tray. Hang high pressure hose on hook of accessory tray.

4. Empty pump of all pumped liquids by pulling recoil handle about six times. This should remove most liquid in pump.
5. Store unit in a clean, dry area,
6. If storing for more than 30 days, see *Long Term Storage* on next page.

WARNING Fuel and its vapors are extremely flammable and explosive which could *JUL* cause burns, fire or explosion resulting in death or serious injury.

STORING FUEL OR EQUIPMENT WITH FUEL IN TANK

- Store away from furnaces, stoves, water heaters, clothes dryers, or other appliances that have pilot light or other ignition source because they could ignite fuel vapors.

Storage

Winter Storage

NOTICE You must protect your unit from freezing temperatures.

- Failure to do so will permanently damage your pump and render your unit inoperable.
- Freeze damage is not covered under warranty.

To protect the unit from freezing temperatures:

1. Empty detergent tank as follows:
 - a. Place suitable container under barbed fitting on detergent tank and remove detergent tube. Remove the tank cover, tip pressure washer forward slightly and empty tank contents into container.
 - b. Reconnect hose to barbed fitting on tank.
 - c. Add 1 pint (0.5 liter) of clean fresh water to detergent tank and close tank cover.
2. Flush detergent tank by running pressure washer with the black spray tip. Flush until tank is empty.
3. Follow steps 1-4 in the previous section After Each Use.
4. Use pump saver, Model 6039, to treat pump. This minimizes freeze damage and lubricates pistons and seals.
5. If pump saver is not available, connect a 3 ft. (1 m) section of garden hose to water inlet adapter. Pour RV-antifreeze (antifreeze without alcohol) into hose. Pull recoil handle twice. Disconnect 3 ft. (1 m) hose.
6. Store unit in a clean, dry area.

Long Term Storage

If you do not plan to use the pressure washer for more than 30 days,, you must prepare the engine and pump for long term storage.

Protect Fuel System

Fuel Additive:

Fuel can become stale when stored over 30 days. Stale fuel causes acid and gum deposits to form in the fuel system or on essential carburetor parts. To keep fuel fresh, use Briggs & Stratton® Advanced Formula Fuel Treatment & Stabilizer, available wherever Briggs & Stratton genuine service parts are sold.

There is no need to drain gasoline from the engine if a fuel stabilizer is added according to instructions. Run the engine for 2 minutes to circulate the stabilizer throughout the fuel system before storage.

If gasoline in the engine has not been treated with a fuel stabilizer, it must be drained into an approved container. Run the engine until it stops from lack of fuel. The use of a fuel stabilizer in the storage container is recommended to maintain freshness.

Storing the Engine

See the engine operator's manual for instructions on how to properly prepare the engine for storage.

Protecting the Pump

To protect the pump from damage caused by mineral deposits or freezing, use Pump Saver, Model 6039, to treat pump. This prevents freeze damage and lubricates pistons and seals.

NOTICE Pump Saver is available as an optional accessory. It is not included with the pressure washer. Contact the nearest authorized service center to purchase Pump Saver.

NOTICE You must protect your unit from freezing temperatures.

- Failure to do so will permanently damage your pump and render your unit inoperable.
- Freeze damage is not covered under warranty.

To use Pump Saver, make sure the pressure washer is turned off and disconnected from supply water. Read and follow all instructions and warnings given on the Pump Saver container.

Pump Saver Storage

1. On the back of the accessory tray, insert rubber strap into first opening until it locks.

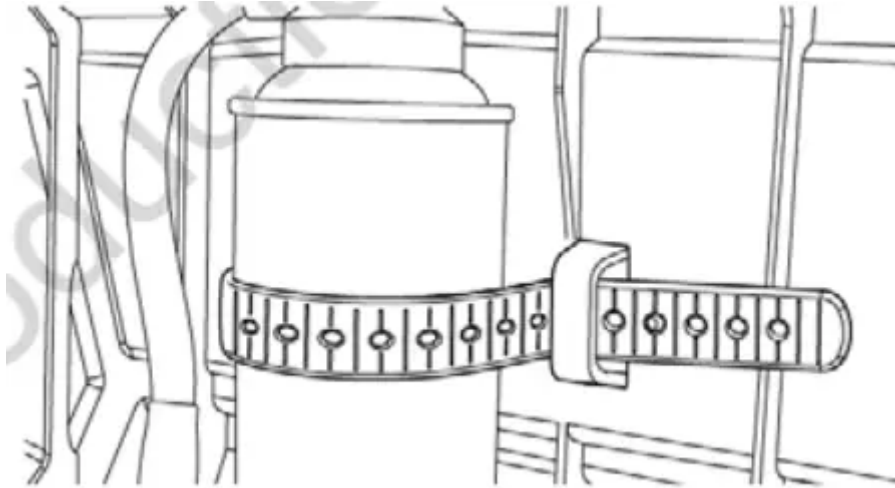

2. Set the Pump Saver bottle in the space between the two slots.
3. Wrap the strap over the bottle and feed through the slot and hook onto knob.

Other Storage Tips

1. DO NOT store fuel from one season to another unless it has been treated as described in Protect Fuel System.
2. Replace fuel container if it starts to rust. Rust and/or dirt in fuel can cause problems if it's used with this unit.
3. Cover unit with a suitable protective cover that does not retain moisture.

WARNING Storage covers could cause a fire resulting to or serious injury.

- DO NOT place storage cover over a hot pressure washer.
 - Let equipment cool for a sufficient time before placing the cover on the equipment.
4. Store unit in a clean and dry area.

Troubleshooting

Problem	Cause	Correction
<p>Pump has following problems: failure to produce pressure, erratic pressure, chattering, loss of pressure, low water volume.</p>	<ol style="list-style-type: none"> 1. Low pressure spray tip installed. 2. Inadequate water supply. 3. Clogged inlet hose screen. 4. Spray tip is obstructed, 5. Connections leak. 6. High pressure hose or spray gun leaks. 	<ol style="list-style-type: none"> 1. Replace with high pressure spray tip. 2. Provide adequate water flow. 3. Check and clean inlet hose screen. 4. Clean spray tip. 5. Tighten connections or replace o-ring. 6. Replace.
<p>Detergent fails to mix with spray.</p>	<ol style="list-style-type: none"> 1. High pressure spray tip installed. 2. Check ball stuck in detergent siphoning system. 3. Detergent tube/tank is clogged or cracked. 	<ol style="list-style-type: none"> 1. Replace with low pressure spray tip. 2. Free check ball. See <i>Detergent Siphoning Check Ball</i> 3. Clean or replace detergent tube/tank.
<p>Engine lacks power; will not start; starts and runs rough or shuts down during operation.</p>	<ol style="list-style-type: none"> 1. Engine rocker switch set to OFF (0) position. 2. Out of fuel. 3. Dirty air cleaner. 4. Spark plug wire not connected to spark plug. 	<ol style="list-style-type: none"> 1. Set engine rocker switch to ON (1) position. 2. Fill fuel tank. 3. Clean or replace air cleaner. 4. Connect wire to spark plug.

Warning



This content is compiled from multiple sources and is provided for reference purposes only. It may not be complete or fully applicable to all situations. If you are unable to resolve your issue, please contact the product manufacturer or an authorized service provider for official support.

Document generated by [ManualsFile](#)

