

Operations

Feature panel

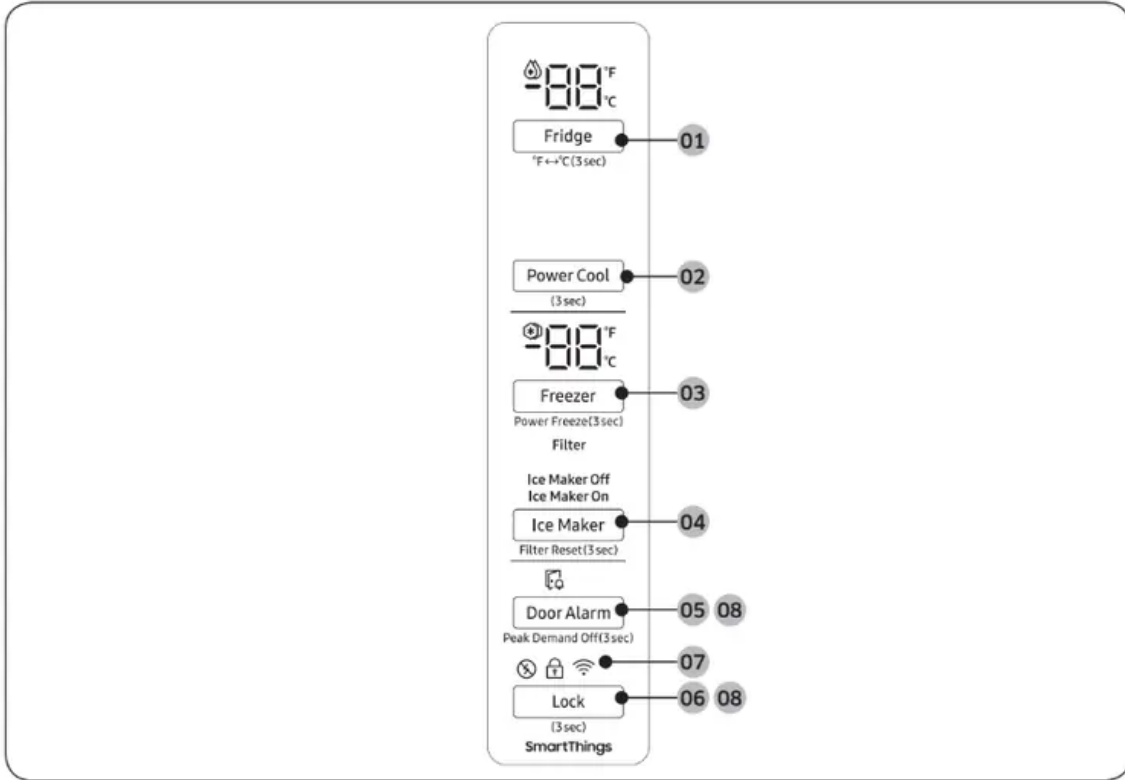

01 Fridge / °F ↔ °C

02 Power Cool

03 Freezer / Power Freeze

04 Ice Maker / Filter Reset

05 Door Alarm / Peak Demand Off

06 Lock

07 Network connection

08 Sabbath Mode

- If a communication error occurs between the temperature display and the main
- The display of the main panel turns on only if the door is opened and turns off if the
- If you set Control Lock on the main panel. the main panel locks automatically 1 minute

01 Fridge / °F ↔ °C (3 sec)



Fridge	<p>You can use the Fridge button to set the fridge temperature.</p> <ul style="list-style-type: none"> • Press Fridge repeatedly to select a desired temperature between 34 °F (1 °C) and 44 °F (7 °C). - The temperature indicator displays the currently set or selected temperature.
°F ↔ °C	<p>You can also use the Fridge button to switch the temperature scale between Celsius and Fahrenheit.</p> <p>To switch the temperature scale, press and hold Fridge for 3 seconds to change the current temperature scale.</p>

02 Power Cool (3 sec)

Power Cool speeds up the cooling process at maximum fan speed.

This is useful to quickly cool food that spoils quickly. or after the door is left open for some time.

The fridge keeps running at full speed for several hours and then returns to the previous temperature. Press and hold Power Cool for 3 seconds.

03 Freezer / Power Freeze (3 sec)

Freezer	<p>You can use the Freezer button to set the freezer temperature.</p> <ul style="list-style-type: none"> • Press Freezer repeatedly to select a desired temperature between 5 °F (-15 °C) and -8 °F (-23 °C). - The temperature indicator displays the currently set or selected temperature.
Power Freeze	<p>Power Freeze speeds up the freezing process at maximum fan speed. The freezer keeps running at full speed for 50 hours and then returns to the previous temperature.</p> <ul style="list-style-type: none"> • To activate Power Freeze, press and hold Freezer for 3 seconds. The corresponding indicator () lights up, and the refrigerator will speed up the freezing process for you. • To deactivate, press and hold Freezer for 3 seconds again. The freezer returns to the previous temperature setting. • To freeze large amounts of food, activate Power Freeze for at least 20 hours before putting food in the freezer.

04 Ice Maker / Filter Reset (3 sec)

Ice Maker	<p>Press Ice Maker to turn the ice maker on or off.</p> <p>The ice maker has 2 indicators (Ice Maker On /Ice Maker Off) to indicate its operating status.</p> <ul style="list-style-type: none">• When the ice maker operates, the corresponding indicator (Ice Maker On) turns on.• When the ice maker is turned off, the corresponding indicator (Ice Maker Off) turns on. To enable ice making, you must turn the ice maker on.
Filter Reset	<p>After about 6 months (and typically, about 300 gallons (1200 L) of water), the Filter indicator blinks red for several seconds when you open the door, reminding you that the filter needs to be replaced. When this happens, replace the filter, and then press and hold Filter Reset for 3 seconds. The filter lifecycle will be reset and the Filter indicator turns off.</p>

05 Door Alarm / Peak Demand Off (3 sec)

Door Alarm	<p>If the door is left open for more than 2 minutes, an alarm will sound and the alarm indicator will blink. You can toggle the alarm on and off by pressing Door Alarm. The alarm is enabled by factory default.</p> <p>If the door is left open for 5 minutes, internal light (in the fridge, freezer) will blink for 5 minutes and turn off. This is for alerting the hearing-impaired person, and it is normal.</p>
Peak Demand Off	<p>The Peak Demand Off function activates/deactivates Smart Grid. Press Door Alarm for 3 seconds to set/clear the Peak Demand Off function.</p>

06 Lock (3 sec)

To prevent accidental setting changes, press and hold Lock for 3 seconds. The main panel will be disabled and the Lock indicator () will turn on.

When Lock is on, the indicator blinks if any button on the main panel is pressed. If you press and hold the button again for more than 3 seconds, Lock will be deactivated. However, Lock will be reactivated if no button is pressed within 1 minute.

07 Network connection

You can control and monitor your refrigerator on the SmartThings app. For more information, see the SmartThings section.



08 Sabbath Mode

The Sabbath mode stays active for 85 hours once it is activated. After that, it will be deactivated automatically.

- To activate, press and hold Door Alarm and Lock simultaneously for 5 seconds to enter Sabbath mode. Then the refrigerator operates in Sabbath mode where the buttons, the display, and the room lamps are all under control.
- To deactivate, press and hold the buttons again for 5 seconds to exit Sabbath mode.

09 Cooling Off

Cooling Off mode (also called Shop mode) is designed for use by retailers when they are displaying refrigerators on a retail floor.

In Cooling Off mode, the refrigerator's fan motor and lights operate normally, but the compressors do not run so that neither the refrigerator nor the freezer run the cooling process.

To enter or exit the Cooling Off mode, press and hold Fridge and Power Cool simultaneously for 6 seconds. Then, when the display blinks, press Lock.

When the Cooling Off mode is on, the refrigerator chime sounds, and the refrigerator shows "0" on the fridge temperature display and "FF" on the freezer temperature display.

SmartThings

Installation Visit the Google Play Store, Galaxy Apps, or Apple App Store and search for "SmartThings".

Download and install the SmartThings app provided by Samsung Electronics to your smart device.

Samsung account

You are required to register your Samsung account to use the app. If you don't have a Samsung account, follow the app's onscreen instructions to create a free Samsung account.

Getting started

Turn on the device you want to connect, open the SmartThings app on your phone, and then follow the instructions below.

If a pop-up appears saying that a new device has been found, tap ADD NOW.

If a pop-up doesn't appear, tap the + button, and then select the device you want to connect from the list of available devices.

If your device isn't in the list of available devices, tap Supported Devices, select the device type (Refrigerator), and then select the specific device model.

Follow the instructions in the app to set up your device. Once setup is complete, your refrigerator will appear as a "card" on your Devices screen.

Refrigerator app

Integrated control

You can monitor and control your refrigerator at home and on the go.

- Tap the refrigerator icon on the SmartThings Dashboard or tap the Devices icon at the bottom of the Dashboard, and then tap the refrigerator "card" to open the Refrigerator page.
- Check the operation status or notifications related to your refrigerator. and then change options or settings if necessary.

Refrigerator settings

Category	Item	Description
Monitoring	Fridge temperature	Displays the desired temperature setting of the fridge.
	Freezer temperature	Displays the current temperature of the freezer.
	Diagnosis	Detects abnormal operations of the refrigerator.
	Energy monitoring	Checks the accumulated power consumption of the refrigerator for the last 180 days.
Functions	Ice making	You can turn the ice making function on or off, and check the current settings of the function.
		You can also check the status and progress of ice making.
	Power Cool	You can turn Power Cool on or off, and check the current settings.
	Power Freeze	You can turn Power Freeze on or off, and check the current settings.
	Fridge temperature	You can set the desired temperature of the fridge.
	Freezer temperature	You can set the desired temperature of the freezer.
	Sabbath Mode	You can activate and deactivate the Sabbath mode.
Alarms	Abnormally high temperature	This alarm is triggered when the fridge or the freezer has abnormally high temperatures.
	Door opening	This alarm is triggered if the fridge door or the freezer drawer is open for a specific time.
	Water filter replacement	This alarm reminds you that the water filter must be replaced.

SMART GRID Function (Demand Response) (applicable models only)



When the refrigerator operates in SMART GRID (Demand Response) mode, the Energy Management Refrigerator function can control energy usage or delay the operation of some functions to save money when energy prices or demand are the highest.

In addition, to use the Smart Grid (Demand Response) function, you must register for the service with your electric company. The company must have an EMS (Energy Management System) that supports SEP (Smart Energy profile).

Using the SMART GRID (Demand Response) Function

This feature monitors energy prices and demand information from your utility company and sends notifications to the refrigerator to run high energy consuming tasks during off-peak times when electricity costs and demand are lower.

If the refrigerator receives a control signal from the utility company, the refrigerator will display the DAL (L3) ~ TALR (L4) levels on the refrigerator display and control the power consumption according to the level.

[Exception condition] The DAL and TALR control signals from a utility company work as long as product performance is maintained.

If the refrigerator receives the SMART GRID (Demand Response) signal (DAL or TALR), the refrigerator will operate in Delay Appliance Load (Display:L3) or Temporary Appliance Load Reduction (Display:L4) mode.

- Delay Appliance Load (L3): The refrigerator responds to a DAL signal by providing a moderate load reduction for the duration of the delay period. This function controls functions that consume a lot of energy such as adjusting the Cooling system, running the defrost cycle, and making ice.
 - When the refrigerator operates in DAL (L3) mode, “L3” is displayed on the refrigerator display.
 - DAL mode is automatically deactivated after it lasts for the amount of time stipulated by the DAL signal (max. 4.5 hours) or when the Peak Demand Off key is pressed.
- Temporary Appliance Load Reduction (L4): The refrigerator responds to a TALR signal by aggressively reducing the load for a short time period. This function reduces energy consumption by stopping the compressor and controlling the functions that consume a lot of energy such as the defrost cycle and making ice.
 - When the refrigerator operates in TALR (L4) mode, “L4” is displayed on the refrigerator display.
 - TALR (L4) mode is automatically deactivated after it lasts for the received duration (max. 15 minutes), or when the Peak Demand Off key is pressed. The mode is immediately deactivated and the refrigerator returns to the normal state when the door is opened or closed, or the dispenser is used.



To check the MAC address

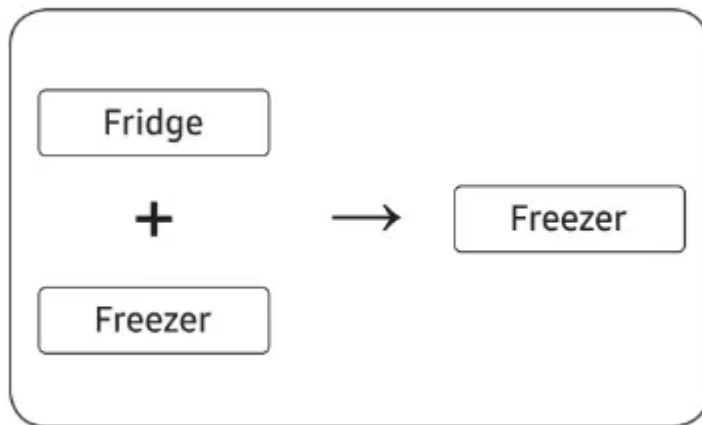

1. In this mode, the MAC address appears on the temperature panel (on both the freezer and the fridge sections of the panel) sequentially for 1 minute. Press and hold both Freezer and Fridge for 6 seconds. The temperature panel blinks. Then, press Freezer again to display the MAC address. The fridge beeps.
2. For example, if the MAC address is "11- 22-33-44-55-66", the temperature panel displays the address for 1 minute in this sequence: "-- / --" → "11 / 22" → "33 / 44" → "55 / 66" → "-- / --". After the 1 minute, the MAC address disappears and the temperature panel returns to the normal state.

Peak Demand Off (Override mode)

When you want the refrigerator to ignore the SMART GRID (Demand Response) signal from the utility company, you can activate Peak Demand Off (Override mode).

When you activate Peak Demand Off (Override mode), the refrigerator ignores the SMART GRID (Demand Response) signal and is not controlled by the utility company.

Activating and deactivating Peak Demand Off (Override mode)

1. Press and hold Door Alarm for 3 seconds.
2. A buzzer sounds and Or' and on' is displayed in the freezer and fridge temperature
3. If the refrigerator receives a SMART GRID (Demand Response) signal from the utility
4. To deactivate Peak Demand Off (Override mode), press and hold Door Alarm for 3
5. A buzzer sounds and Or' and oF' is displayed in the freezer and fridge temperature

Using the Energy Management Function

The Energy Management function enables you to control and monitor your Energy Management refrigerator using the SmartThings app for your convenience.

1. Operational Status

You can check the DR and Peak Demand Off (Override mode) status.

2. Energy Consumption Reporting

Shows the accumulated power consumption. Power consumption data is updated

3. Delay Defrost Capability

-The Delay Defrost Capability function saves energy by delaying the defrost operation to a time specified by the user. You can configure the time. And this function will save energy during the specified period in a 24 hour cycle. If the time is not set, the function works with the default time settings. The default time settings are below:

- 6 am to 10 am: 1st. November ~ 30th. April

- 3 pm to 7 pm: 1st. May ~ 31th. October

To change the time setting for the Delay Defrost Capability

You can change the time setting for the Delay Defrost Capability on the app.

Provision for Open Access to the Connected Product Requirements

1. SGIP Open Standards (Smart Energy Profile 2.0 - <http://www.csep.org/>)

- Energy Consumption Reporting
- Demand Response

2. Samsung OPEN API

- Operational Status. User Settings & Messages
- ICE Maker Status: GET /icemaker/status/vs/0
- Door Open Alarm: GET /doors/vs/0
- DR Status: GET /drlc/vs/0
- Delay Defrost Capability Set Schedule of the Defrost Delay: POST /defrost/reservation/vs/0?op=add
- Get Schedule of the Defrost Delay : GET /defrost/reservation/vs/0
- Delete Schedule of the Defrost Delay: POST /defrost/reservation/vs/0?op=remove
- Defrost Delay On/OFF: POST /defrost/delay/vs/0

Special features

Auto ice maker

The refrigerator has a built-in ice maker that automatically dispenses ice so that you can enjoy filtered cubed ice.

Ice making

After you have installed your refrigerator and plugged it in, follow these instructions to ensure proper ice making and to keep the ice bucket full of ice:

1. Let the refrigerator operate for at least 24 hours to ensure optimal performance.
2. Dispense the first 4 to 6 ice cubes into a glass.
3. Wait another 8 hours and dispense another 4 to 6 ice cubes.
4. Then, wait another 16 hours and dispense the first glass-full of ice.

Diagnosis

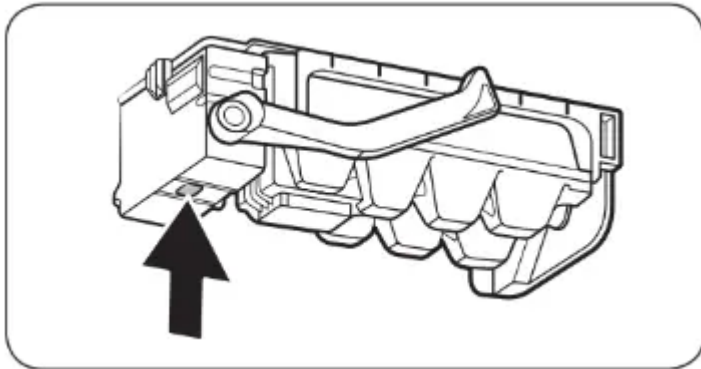

If ice does not dispense, first check the ice maker.

1. Press Test on the bottom of the ice
2. You will hear another chime if the ice

If You Turn the Ice Maker Off

If you press Ice Maker to turn the ice maker off, make sure to remove all ice cubes from the ice bucket. Remaining ice cubes may clump together, making it difficult to remove them.

Water clouding

Water supplied to the refrigerator flows through a core alkaline filter. During this filtering process, the water pressure of the water increases and the water becomes saturated with oxygen and nitrogen. This causes the water to look misty or cloudy temporarily when dispensed. This is normal and the water will look clear after a few seconds.

To secure more storage space (applicable models only)

To secure more space, remove the upper drawer (A), lower drawer (B), and lower drawer cover (C). Then, insert the provided bottom shelf (D).

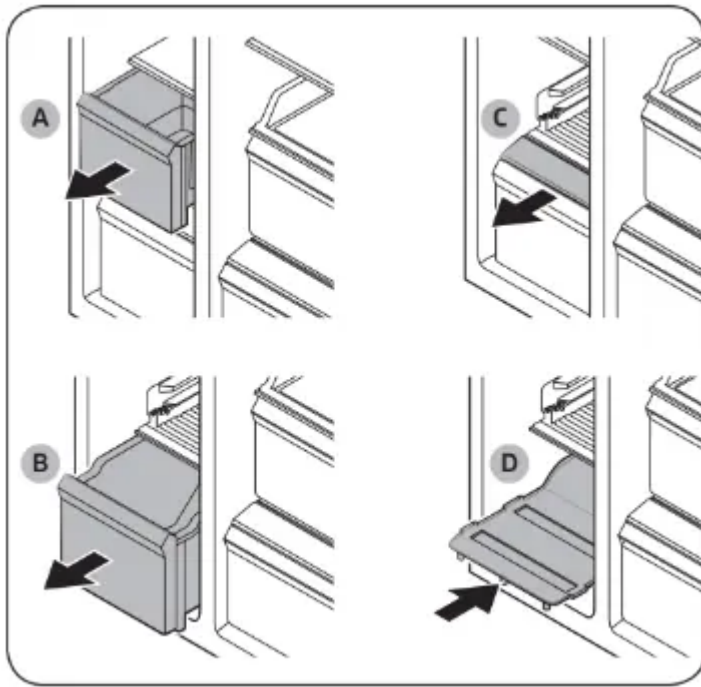

Maintenance

Auto Icemaker

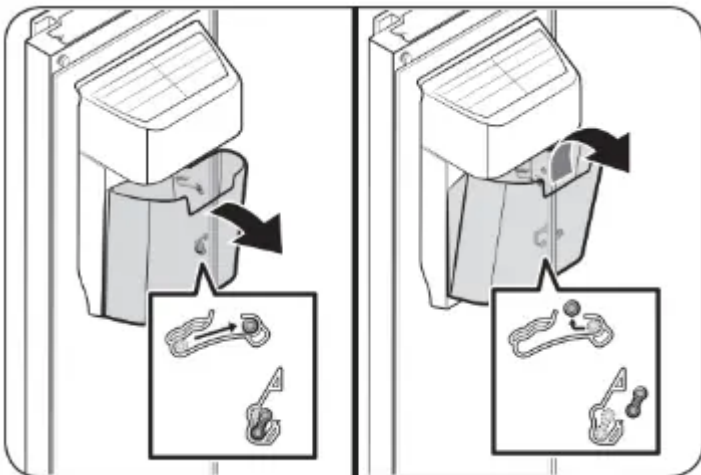

To remove the ice from the Auto Icemaker, pull the ice bucket.

1. Unlock the ice bucket by pulling it out
2. Press and hold Ice Maker for 3 seconds

Shelves (fridge/freezer)

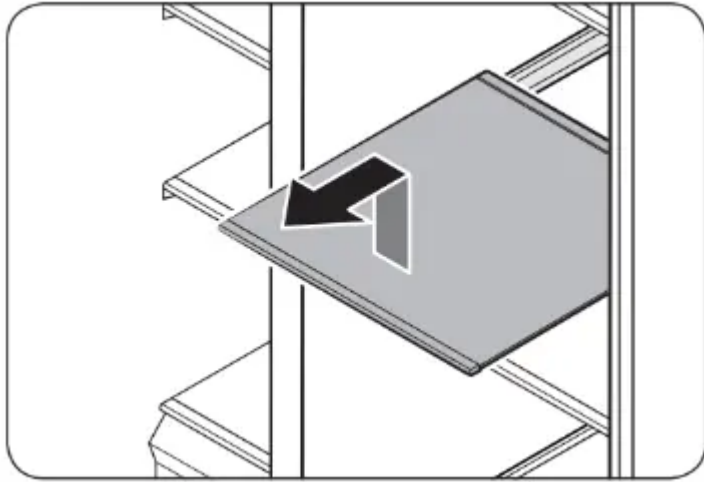

Pull the shelf out as far as it goes. Then lift it up and remove it.

Door bins

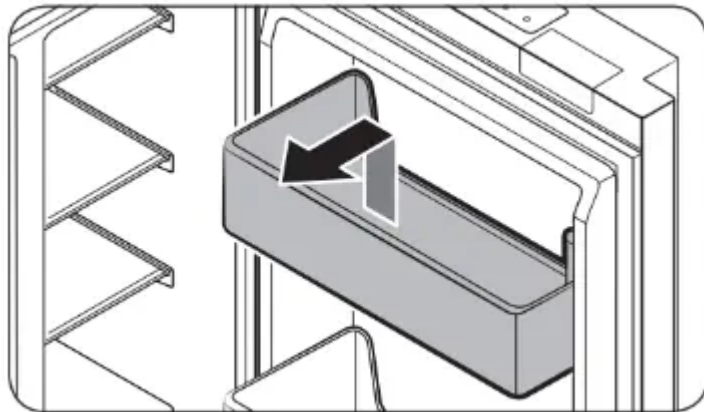

To remove a door bins. hold the front sides of the bin and gently lift up to remove.

Drawers

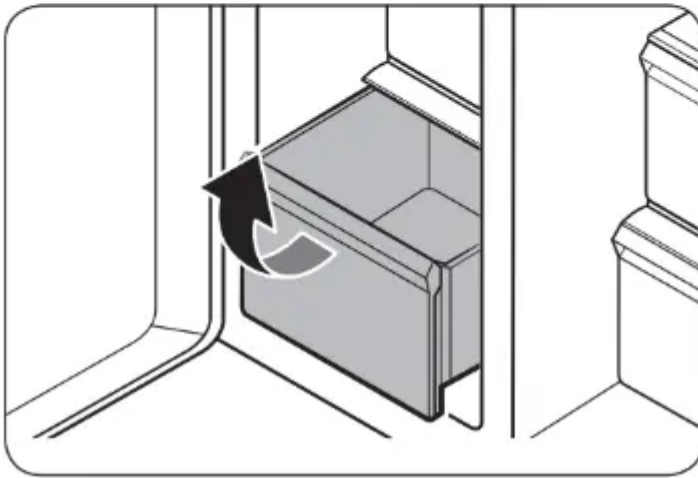
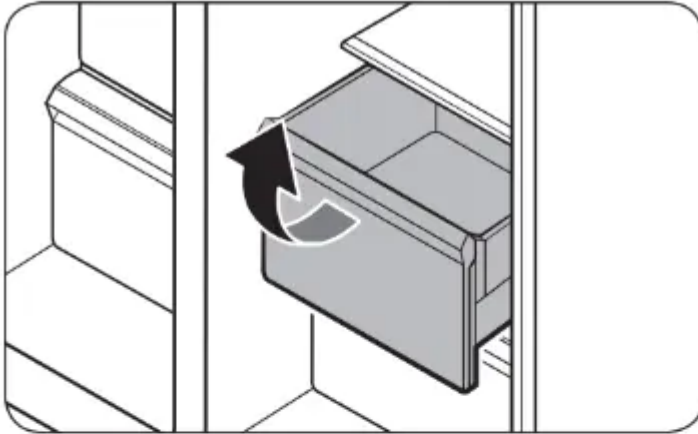

To remove, pull the drawers out as far as they go, and then lift up slightly and pull.

Drawer cover

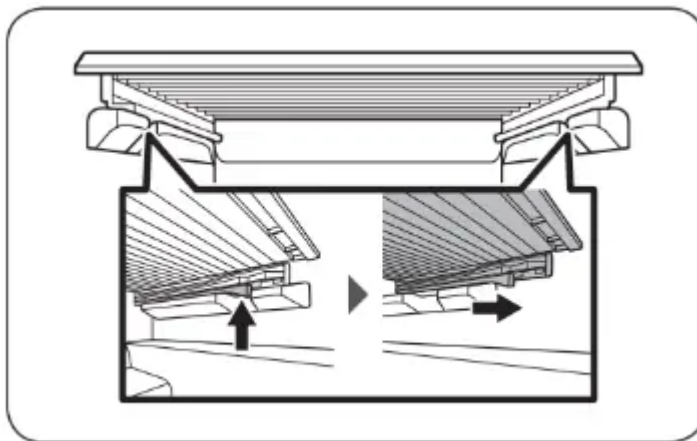

While pushing the left and right hooks underneath the drawer cover, pull the drawer cover to remove.



Cleaning

Interior and exterior

Regularly use a dry cloth to remove all foreign substances such as dust or water from the power plug terminals and contact points.

1. Unplug the power cord.
2. Use a moistened, soft, lint-free cloth or paper towel to clean the refrigerator's interior
3. When done, use a dry cloth or paper towel to dry well.
4. Plug in the power cord.

Rubber seals

If the rubber seals of a door become dirty, the door may not close properly and reducing refrigerator performance and efficiency. Use a mild detergent and damp cloth to clean the rubber seals. Then, dry well with a cloth.

Rear panel

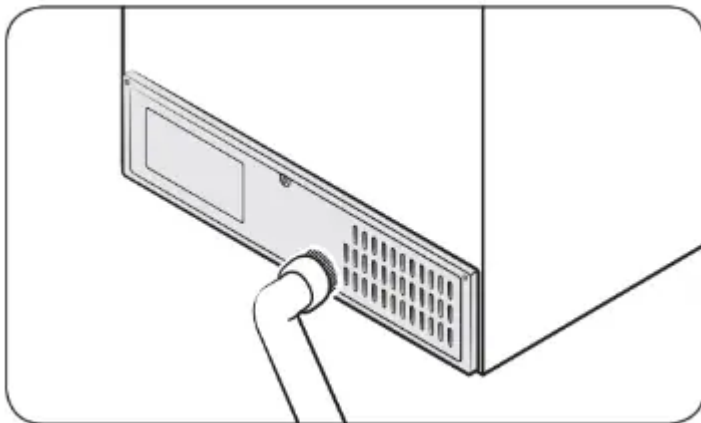

To keep cords and exposed parts of the rear panel free of dirt, vacuum the panel once or twice a year.

Replacement

Water filter

The Filter Reset indicator (**Filter**) turns red to let you know it is time to replace the water filter. Before replacing the filter, make sure the water supply line is shut off.

1. Shut off the water supply line.
2. Turn the knob of the filter cartridge 90 degrees counterclockwise (1/4 turn). The filter cartridge unlocks.

3. Pull out to remove the cartridge.

- If the water filter is severely contaminated, the cartridge may not be easy to remove. If that is the case, use force to remove the cartridge.
- To prevent water leaks from the filter opening, pull the cartridge straight out while removing it.

4. Insert a new filter cartridge. Use only Samsung-provided or approved filters.

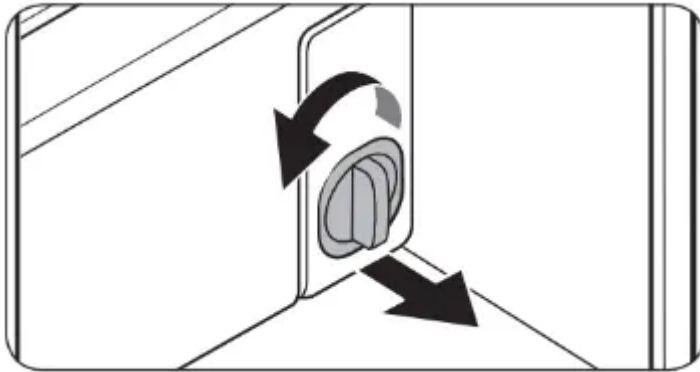

5. Turn the cartridge knob clockwise to lock into place.

6. Press and hold Ice Maker on the main panel for 3 seconds to reset the life cycle detector. The Filter Reset indicator (**Filter**) turns off.

7. When you are done replacing the filter, open the water valve and run water through the dispenser for about 7 minutes. This is to remove impurities and air from the water line.

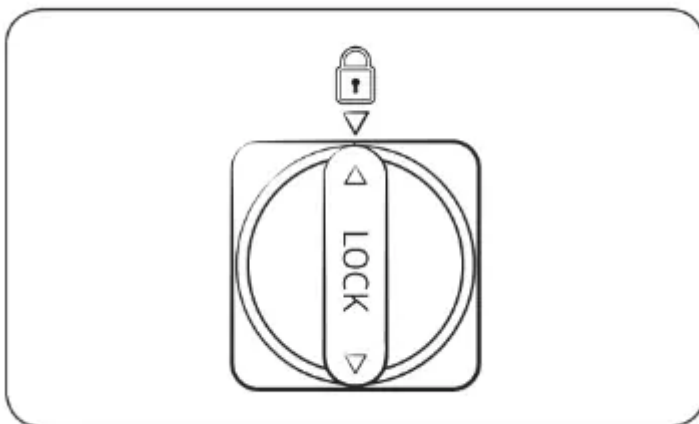

Reverse osmosis water filtration system

The water pressure of the water supply system to a reverse osmosis water filtration system must be between 30 to 120 psi (206 to 827 kPa).

The water pressure of the reverse osmosis water filtration system to the refrigerator's cold water line must be at least 40 psi (276 kPa). If the water pressure is below these specifications:

- Check if the sediment filter in the reverse osmosis system is blocked. Replace the filter
- Refill the water tank in the reverse osmosis system with water.
- If your refrigerator has a water filter. it may further reduce the water pressure when

For more information or servicing. contact a licensed plumbing professional.

Ordering a new filter

To purchase a new water filter. contact a local Samsung service center.

LED Lamps

To replace the lamps of the refrigerator. contact a local Samsung service center.

Troubleshooting

Before calling for service. review the checkpoints below. Any service calls regarding normal situations (No Defect Cases) will be charged to users.

General

Temperature

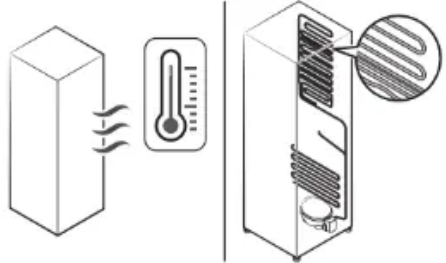
Symptom	Possible causes	Solution
Fridge/ freezer does not operate. Fridge/ freezer temperature is warm.	Power cord is not plugged in properly.	Properly plug in the power cord.
	Temperature control is not set correctly.	Set the temperature lower.
	Refrigerator is located near a heat source or direct sunlight.	Keep the refrigerator away from direct sunlight or a heat source.
	Not enough clearance between refrigerator and nearby walls or cabinets.	We recommend that the gap between the refrigerator and nearby walls (or cabinets) is more than 2" (50 mm).
	The refrigerator is overloaded. Food is blocking the refrigerator vents.	Do not overload the refrigerator. Do not allow food to block vents.
Fridge/ freezer is over-cooling.	Temperature control is not set correctly.	Set the temperature higher.
Interior wall is hot.	Refrigerator has heat-proof piping in the interior wall.	<p>To prevent condensation from forming, the refrigerator has heat-proof piping in the front corners. If the ambient temperature rises, this equipment may not work effectively. This is not a system failure.</p> 

Odour

Symptom	Possible causes	Solution
Refrigerator has odours.	Spoiled food.	Clean the refrigerator and remove any spoiled food.
	Food with strong odours.	Make sure strong smelling food is wrapped airtight.

Frost

Symptom	Possible causes	Solution
Frost around the vents.	Food is blocking the vents.	Make sure no food blocks the refrigerator vents.
Frost on interior walls.	Door is not closed properly.	Make sure food does not block the door. Clean the door gasket.

Condensation

Symptom	Possible causes	Solution
Condensation forms on the interior walls.	If door is left open, moisture enters the refrigerator.	Remove the moisture and do not leave a door open for extended periods of time.
	Food with high moisture content.	Make sure food is wrapped airtight.

Water/ice

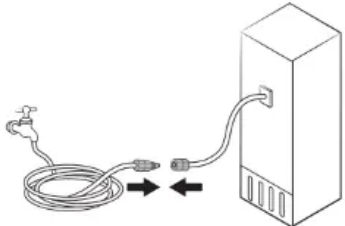

Symptom	Possible causes	Solution
Water flow is weaker than normal.	Water pressure is too low.	Make sure the water pressure is between 20 and 125 psi (138 and 862 kPa).
Ice maker makes a buzzing sound.	The ice maker function is activated, but the water supply to the refrigerator has not been connected.	Activate the Ice Maker off.
Ice maker does not make ice.	Ice maker has just been installed.	You must wait for 12 hours for the refrigerator to make ice.
	Freezer temperature is too high.	Set the freezer temperature below 0 °F (-18 °C) or -4 °F (-20 °C) in warm ambient air.
	Ice maker is off.	Turn on the ice maker.
Ice does not dispense.	Ice may jam if the ice dispenser is not used for a long time (approx. 3 weeks).	If you won't be using the refrigerator for a long time, empty the ice bucket and turn off the ice maker.
	Ice bucket is not properly inserted.	Make sure the ice bucket is properly inserted.
	Water line is not connected properly or water supply is not on.	Check if the water line is installed correctly. Check if the water line stop cock is closed. 
Water does not dispense.	Water line is not connected properly or water supply is not on.	Check if the water line is installed correctly. Check if the water line stopcock is closed.

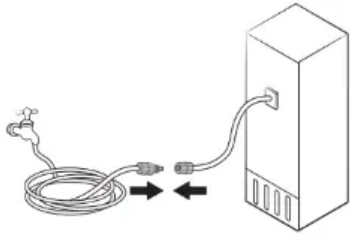
		
	<p>A third-party water filter was installed.</p>	<ul style="list-style-type: none"> • Use only Samsung-provided or approved filters. • Unapproved filters may leak and damage the refrigerator.
	<p>Water filter indicator turns on or blinks.</p>	<p>Replace the water filter. After replacing, reset the filter indicator sensor.</p>

Do you hear abnormal sounds from the refrigerator?

Before calling for service, review the checkpoints below. Any service calls related to normal sounds will be charged to the user.

These sounds are normal.

- When starting or ending an operation, the refrigerator may make sounds similar to a car engine igniting. As the operation stabilizes, the sounds will decrease.

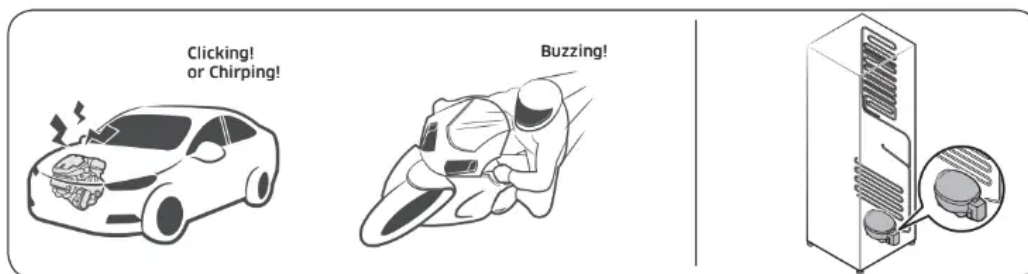

- While the fan is operating, these sounds may occur. When the refrigerator reaches the set temperature, no fan sound will occur.



- During a defrost cycle, water may drip on the defrost heater, causing sizzling sounds.



- As the refrigerator cools or freezes, refrigerant gas moves through sealed pipes, causing bubbling sounds.

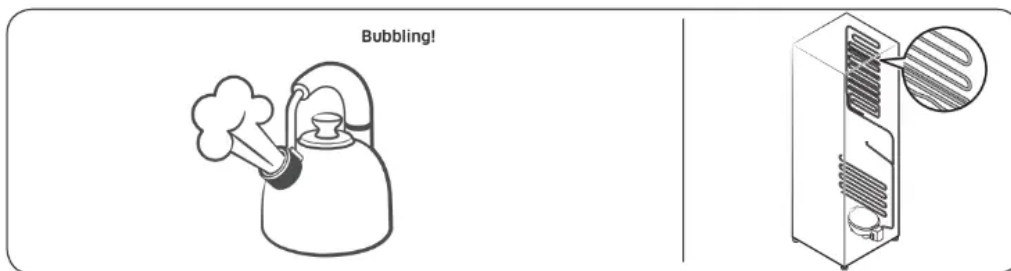

- As the refrigerator temperature increases or decreases, plastic parts contract and expand, creating knocking noises. These noises occur during the defrosting cycle or when electronic parts are working.

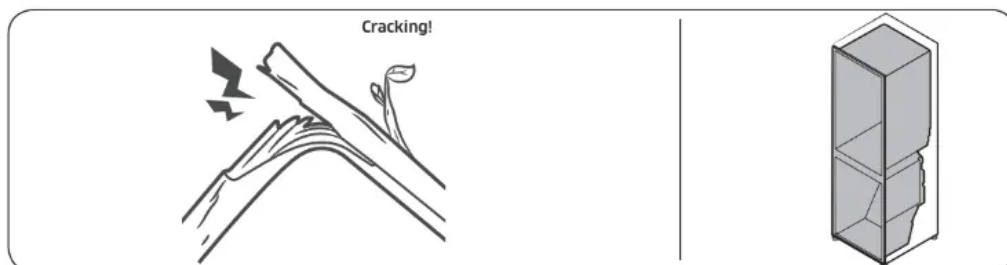

- For ice maker models: When the water valve opens to fill the ice maker, buzzing sounds may occur.

- Due to pressure equalizing when opening and closing the refrigerator door, whooshing sounds may occur.

SmartThings

Symptom	Action
Could not find "SmartThings" in the app market.	<ul style="list-style-type: none"> • The SmartThings app is not available for some tablet and iPad and some smartphone. - support that [Android] OS 6.0 or higher(minimum 2GB RAM Size) - support that [iOS]10.0 or higher/iPhone6 or higher.
The SmartThings app fails to operate.	<ul style="list-style-type: none"> • The SmartThings app is available for applicable models only. • The old Samsung Smart Refrigerator app cannot connect with Samsung Smart Home models.
The SmartThings app is installed but is not connected to my refrigerator.	<ul style="list-style-type: none"> • You must log into your Samsung account to use the app. • Make sure that your router is operating normally. • If you have not connected your refrigerator to the SmartThings App after the app was installed, you must make the connection using the device registration function of the app.
Could not log into the app.	<ul style="list-style-type: none"> • You must log into your Samsung account to use the app. • If you don't have a Samsung account, follow the app's onscreen instructions to create one.
An error message appears when I try to register my refrigerator.	<ul style="list-style-type: none"> • Easy Connection may fail due to the distance from your access point (AP) or electrical interference from the surrounding environment. Wait a moment and try again.
The SmartThings app is successfully connected to my refrigerator but does not run.	<ul style="list-style-type: none"> • Exit and restart the SmartThings app or disconnect and reconnect the router. • Unplug the power cord of the refrigerator, and then plug it in again after 1 minute.

Smart Grid (applicable models only)

Symptom	Action
<p>What Do I Need to use the Energy Management and Smart Grid functions?</p>	<p>To use the Smart Grid (Demand Response) and Energy Management functions on your refrigerator, you need the following:</p> <p>Devices</p> <ul style="list-style-type: none"> • A wireless access point (router) • A Samsung Energy Management-supported refrigerator • A smartphone <p>Registration</p> <ul style="list-style-type: none"> • Connect your refrigerator to your home Wi-Fi network. • Register for the EMS service with your electric company. Your electric company must have an EMS (Energy Management System) supporting SEP (Smart Energy profile). <p>App</p> <ul style="list-style-type: none"> • Download the SmartThings app from the Google Play Store, Apple App Store, or Samsung Galaxy Apps. • Install and run the SmartThings app on your smartphone.
<p>Why isn't the Energy Management function working normally?</p>	<ul style="list-style-type: none"> • Make sure that your home router is operating normally with proper Internet service and connection. • Make sure that the refrigerator is connected to the AP (router). <p>Checkpoints</p> <ul style="list-style-type: none"> • Connect your smartphone to the router (AP, Access Point), and then check if you can browse the Internet on the smartphone.
<p>Why isn't the Delay Defrost Capability working normally?</p>	<ul style="list-style-type: none"> • Make sure that your home router is operating normally with proper Internet service and connection.

Warning

This content is compiled from multiple sources and is provided for reference purposes only. It may not be complete or fully applicable to all situations. If you are unable to resolve your issue, please contact the product manufacturer or an authorized service provider for official support.



