

Installation

Refrigerator at a glance

The actual refrigerator and provided parts of your refrigerator may differ from the illustrations in this manual, depending on the model and the country.

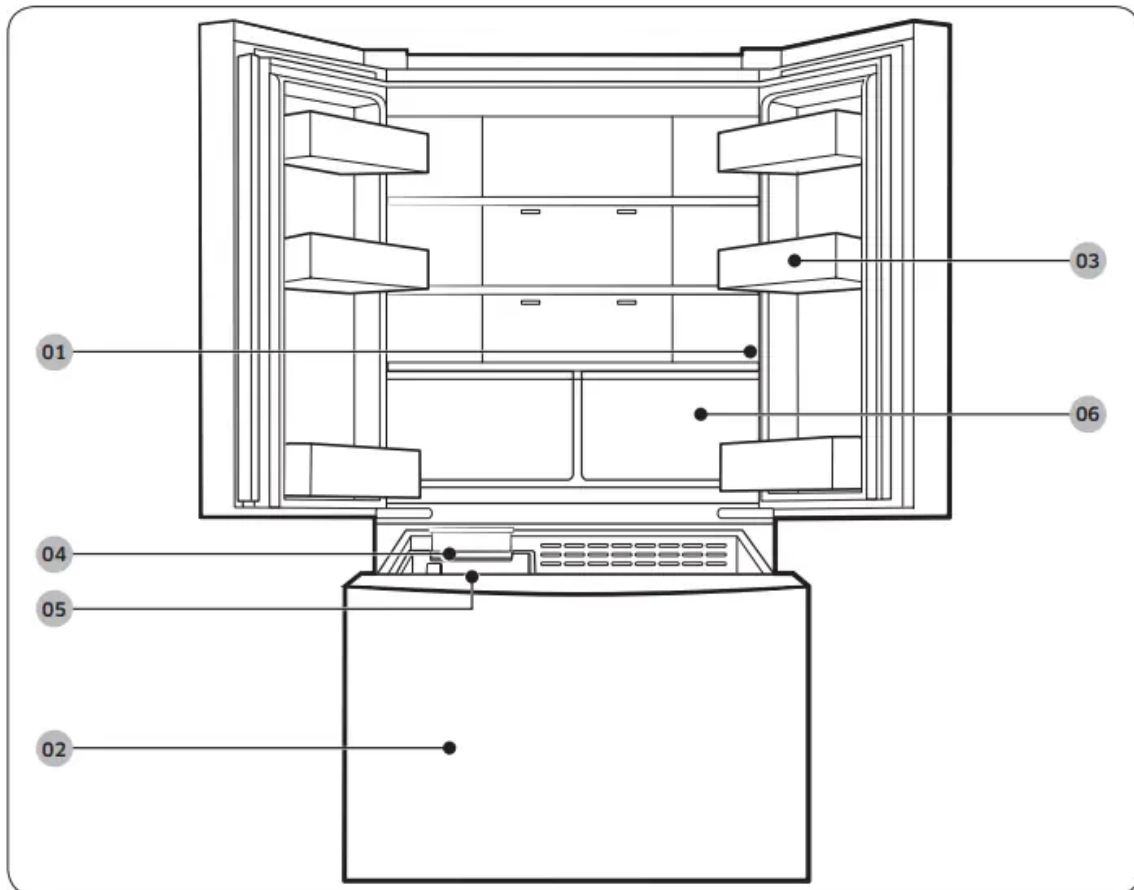

1. Main panel
2. Freezer
3. Door bins
4. Ice Maker
5. Ice bucket
6. Fridge drawers

NOTE

- For energy efficiency, keep all shelves, drawers, and baskets in their original positions.
- When closing the door, make sure the vertical hinged section is in the correct position to avoid scratching the other door.
- If the vertical hinged section is reversed, put it back into the correct position, and then close the door.

- Moisture may form at times on the vertical hinged section.
- If you close a door forcefully, the other door may open.
- If the internal or external LED lamp is out of order, contact a local Samsung service center.
- If the door is left open for too long, the top internal LED will blink. This is normal.

Door bins: Your refrigerator ships with door bins of different types and sizes. If the door bins for your refrigerator were packaged separately, use the figure below to help you position the bins properly.

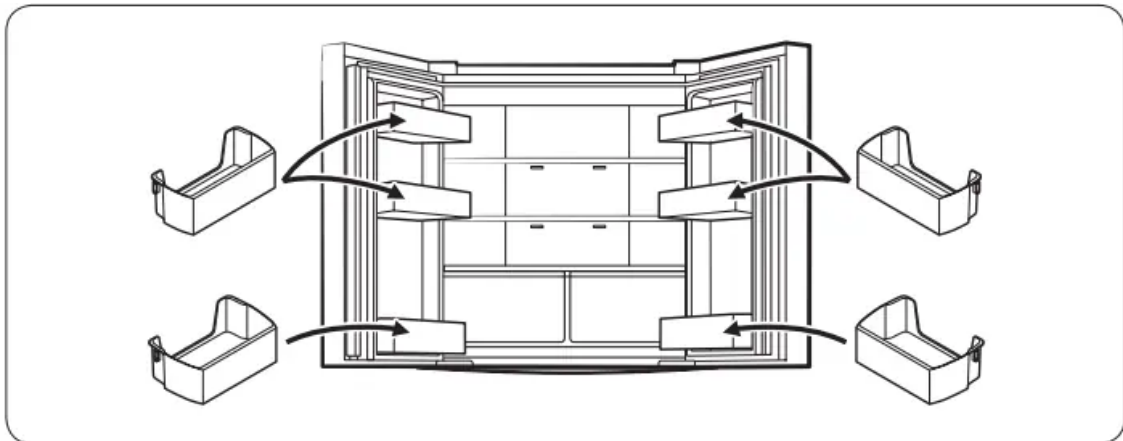

Step-by-step installation

STEP 1 Select a site

Select a site that:

- Has a solid, level surface without carpeting or flooring that may obstruct ventilation
- Is away from direct sunlight
- Has adequate room for opening and closing the door
- Is away from any heat sources
- Provides room for maintenance and servicing
- Has a temperature range between 50 °F (10 °C) and 109 °F (43 °C)

Clearance

See the following figures and tables for space requirements for installation.

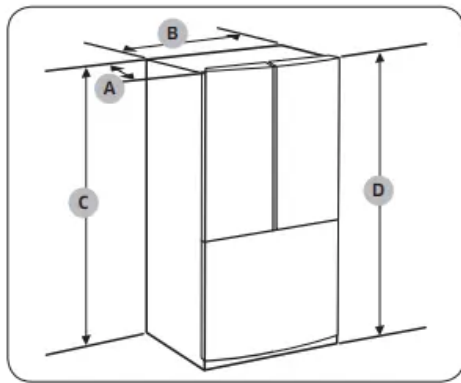

Model	RF18**	RF20**
Depth "A"	28 1/8" (715 mm)	30 1/8" (765 mm)
Width "B"	32 1/8" (817 mm)	32 1/8" (817 mm)
Height "C"	68 7/8" (1749 mm)	68 7/8" (1749 mm)
Overall Height "D"	70" (1776 mm)	70" (1776 mm)

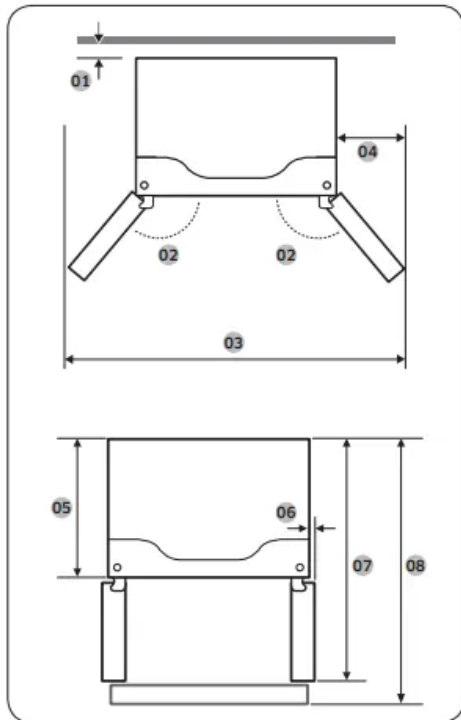

Model	RF18**	RF20**
01	2" (50 mm)	2" (50 mm)
02	5 1/4" (135°)	5 1/4" (135°)
03	54 7/8" (1393 mm)	54 7/8" (1393 mm)
04	11 1/2" (291 mm)	11 1/2" (291 mm)
05	24 1/2" (625 mm)	26 1/2" (675 mm)
06	1 1/4" (31.5 mm)	1 1/4" (31.5 mm)
07	41 1/2" (1056 mm)	43 1/2" (1101 mm)
08	42 1/2" (1082 mm)	44 1/2" (1132 mm)

NOTE
The measurements in the table above may differ slightly from the actual measurements, depending on the measuring and rounding method.

STEP 2 Flooring

If the refrigerator cannot pass through the entrance due to its size, see STEP 3 Door removal for entrance.

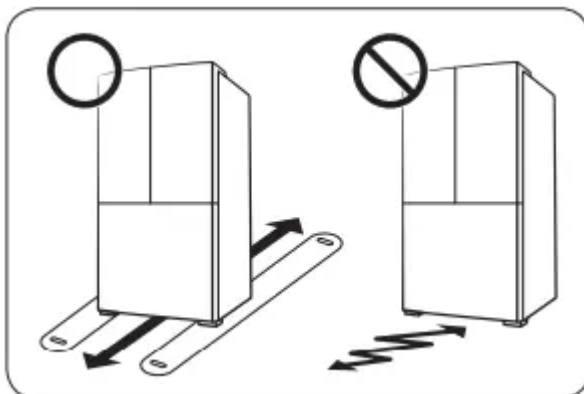

NOTE: To prevent floor damage, make sure the front leveling legs are in the upright position.

- The surface you install the refrigerator on must support a fully loaded refrigerator.
- To protect the floor, put a large piece of cardboard along the path to the refrigerator's final installation location.
- Once the refrigerator is in its final position, do not move it unless necessary to protect the floor. If you have to move the refrigerator, place thick paper or cloth such as old carpets along the path of movement.

STEP 3 Door removal for entrance

If the refrigerator cannot pass through the entrance to your home or kitchen due to its size, follow these instructions to remove and then re-install the refrigerator's doors. If you do not need to remove the doors, go to page 26 to continue the installation procedure.

Tools required (not provided)

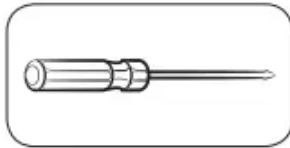

Phillips screwdriver

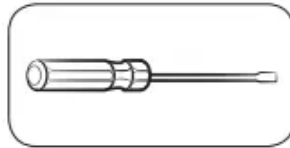

Flat-head screwdriver

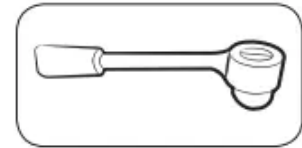

Socket wrench $\frac{3}{8}$ " (10 mm)

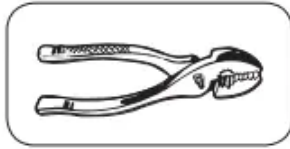

Pliers



Allen wrench $\frac{1}{4}$ " (5 mm)

Detach the fridge doors

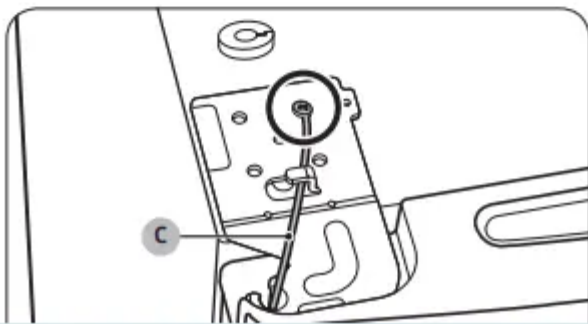
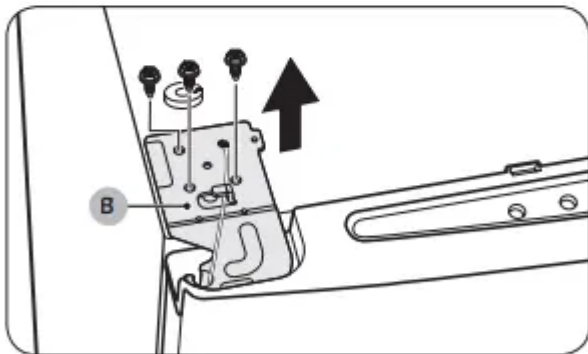
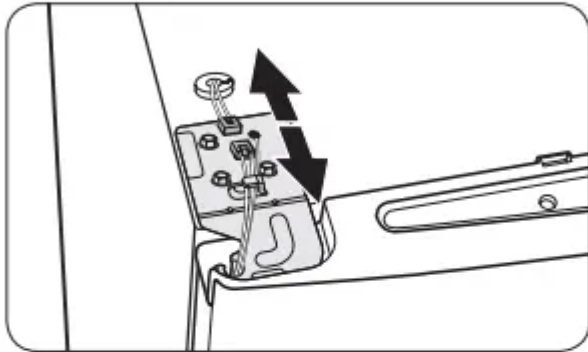
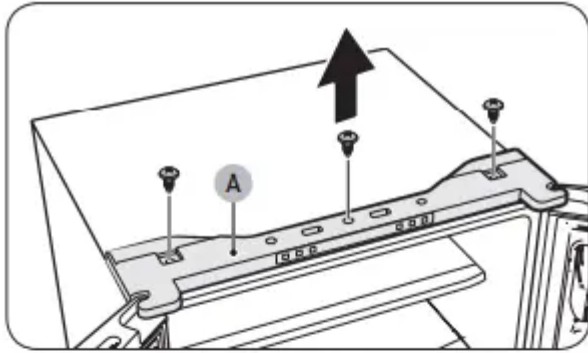

1. Use a Phillips screwdriver to remove the screws fastening the top cover (A).
2. Disconnect the wires on the top of the refrigerator.
3. Use a socket wrench (3/8" / 10 mm) to remove the screws fastening the top hinge (B).
4. Use a Phillips screwdriver to remove the screw fastening the ground wire (C).

5. Remove the top hinge from the door.

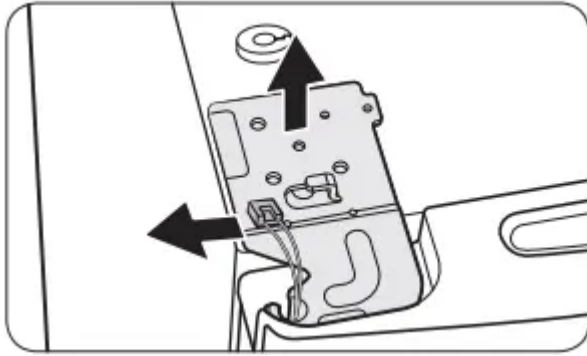

6. Gently pull up the fridge door to remove. Do not apply excessive force to the door. The door may fall, causing physical injury.

7. Lay the door down on a flat surface.

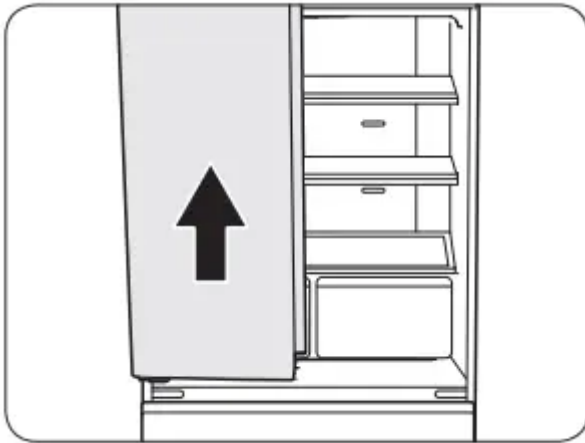

To reattach the fridge doors: After moving the refrigerator to its final location, reattach the doors by following the removal instructions in the reversed order.

Detach the freezer drawer

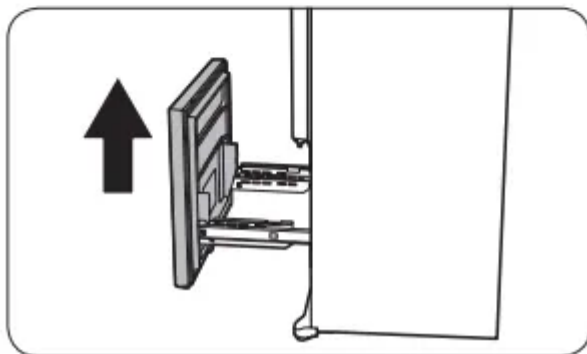
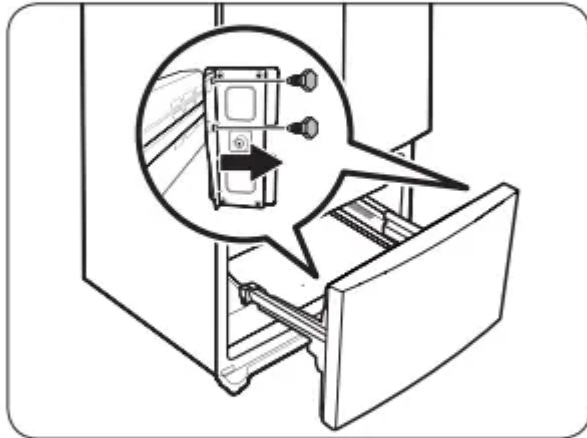
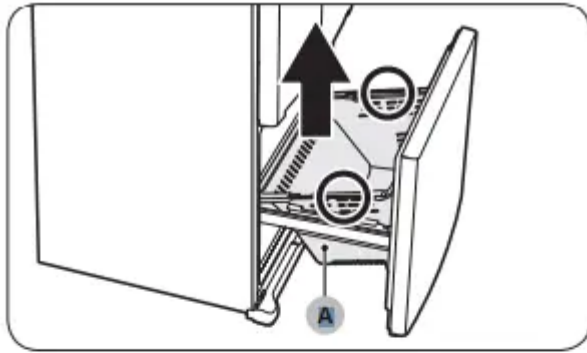

1. Fully open the freezer drawer, and then lift the drawer basket (A) to remove.
2. Use a socket wrench (3/8" / 10 mm) to remove the 4 screws fastening the door.
3. Lift the freezer door from the rails to remove.

To reattach the freezer drawer

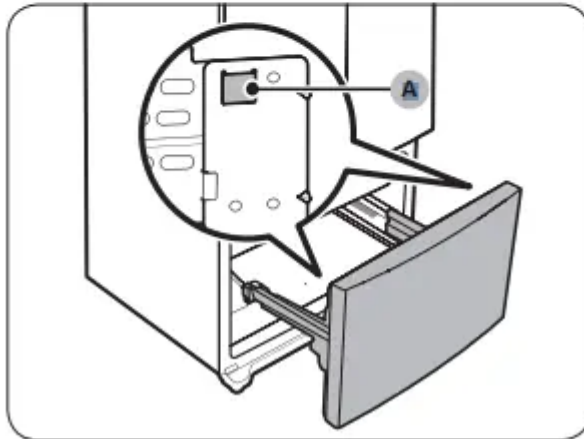
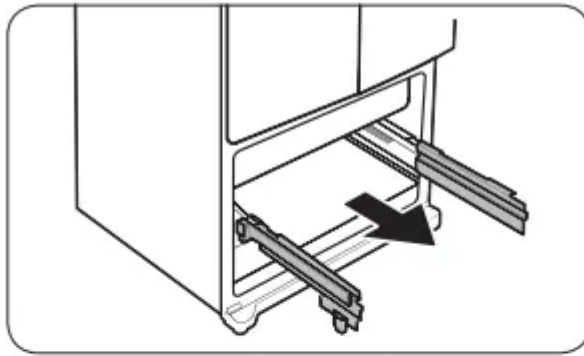

1. Fully pull out the freezer drawer rails.
2. Attach the freezer door to the slots (A) at the side of the rails.
3. Use a socket wrench (3/8" / 10 mm) to fasten the door to the rail with 4 screws.
4. Insert the freezer basket back into its position.

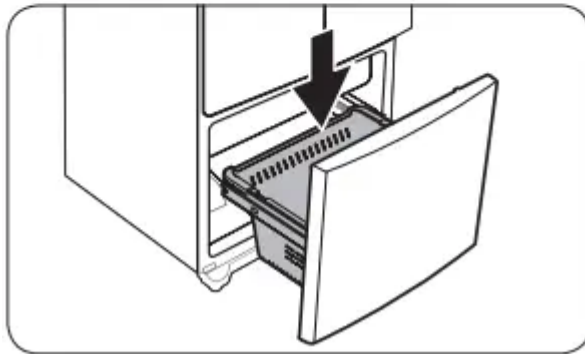
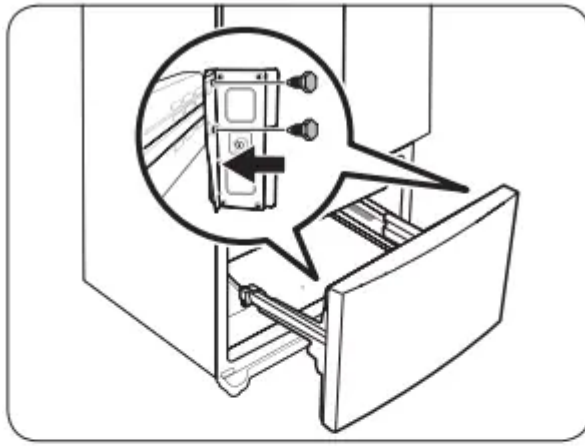

STEP 4 Leveling the refrigerator

Level the refrigerator using the special screws (levelers) on the front legs. Use a flat-head screwdriver to turn the levelers.

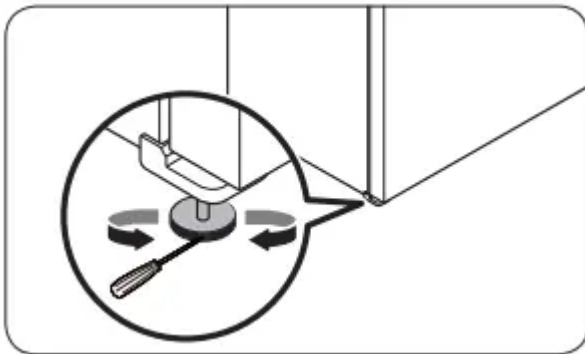

- To adjust the height of the left side: Insert a flat-head screwdriver into the leveler of the left side front leg. Turn the leveler clockwise to raise the left side or turn it counterclockwise to lower.
- To adjust the height of the right side: Insert a flat-head screwdriver into the leveler of the right side front leg. Turn the leveler clockwise to raise the right side or turn it counterclockwise to lower.

STEP 5 Align the fridge doors

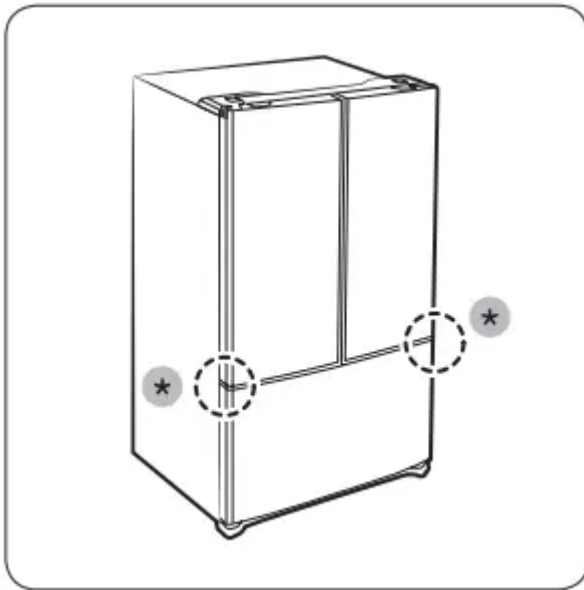

- Before aligning the fridge doors, make sure the refrigerator is level. Refer to the “Leveling the refrigerator” section for detailed instruction.
- You can use the adjustment parts (*) at the bottom of both fridge doors to raise or lower the door.

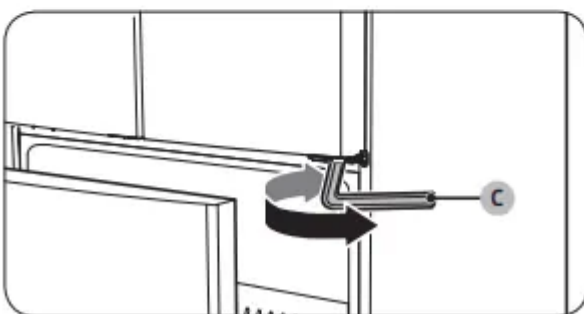
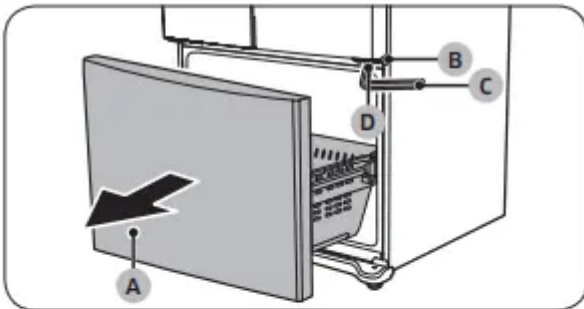

1. Fully open the freezer drawer (A), and then find the middle hinge (B).
2. Insert the Allen wrench (C) into the shaft (D) of the middle hinge.
3. Turn the Allen wrench (C) clockwise or counterclockwise to raise or lower the door.
4. Use the Pliers (D) to insert the provided snap ring (E) in the gap between the hinge-grommet (F) and the middle hinge (G). The number of snap rings depends on the gap.

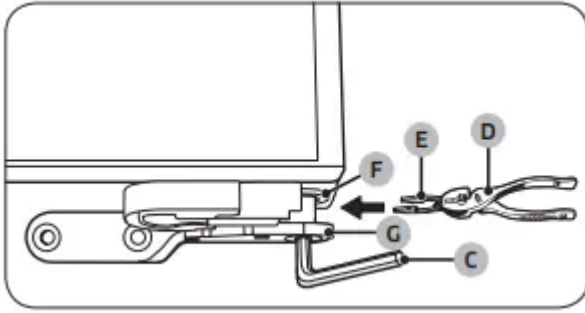

STEP 6 Connect the water dispenser line (applicable models only)

A water dispenser with a filter is one of the helpful features on your new refrigerator. To help promote better health, the water filter removes unwanted particles from your water. However, it does not sterilize or destroy microorganisms. You may need to purchase a water purifying system to do that.

The water line also connects to the ice maker. For the ice maker to operate properly, water pressure of 30 to 120 psi (206 to 827 kPa) psi is required. If the refrigerator is installed in an area with low water pressure (below 30 psi / 206 kPa), you can install a booster pump to compensate for the low pressure.

After you have connected the water line, make sure the water storage tank inside the refrigerator is properly filled. To do this, press the water dispenser lever until water runs from the water outlet.

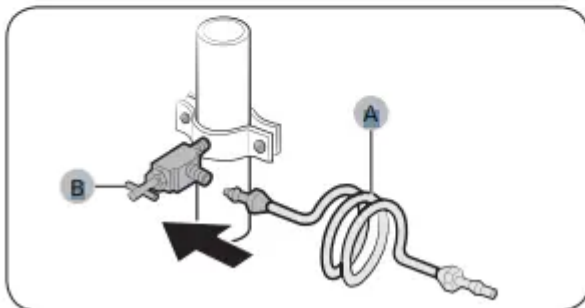
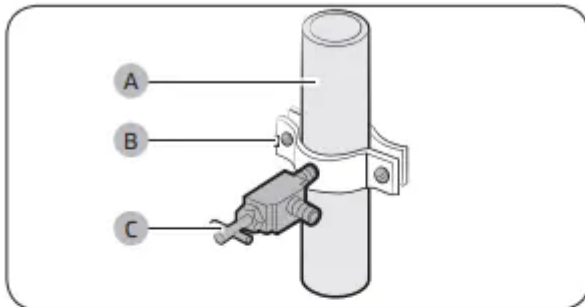

1. Shut off the main water source.
2. Insert the pipe clamp (B) and the shutoff valve (C) into the cold water line (A).
3. Connect the water line installation kit (A) to the shutoff valve (B)



Connect the water supply line to the refrigerator - There are several items you must purchase to complete this connection. You may find these items sold as a kit at your local hardware store.

Copper Tubing	<ul style="list-style-type: none"> • 1/4" copper tubing • 1/4" compression nut (1 pc) • Ferrule (2 pc)
Plastic Tubing	<ul style="list-style-type: none"> • 1/4" plastic tubing → Molded end (Bulb) • 1/4" compression nut (1 pc)

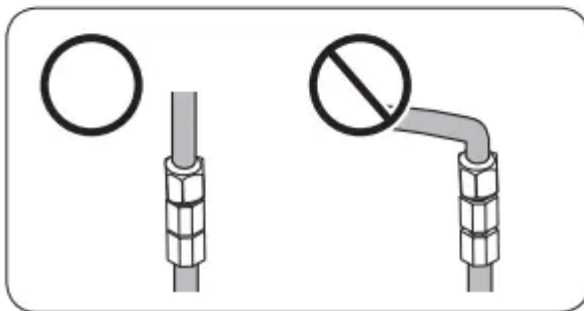
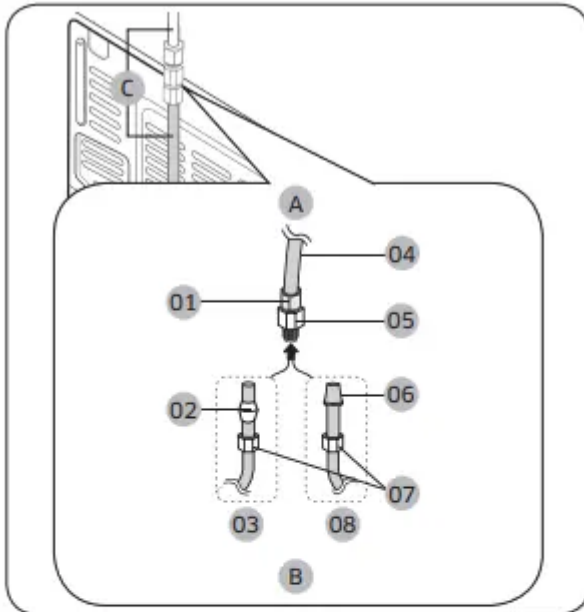

- A. Refrigerator
- B. Household water supply line
- C. Water Line: must be kept straight.
- 01 Compression Nut (1/4") (Assembled)
- 02 Ferrule (Not supplied)
- 03 Copper tubing (Not supplied)
- 04 Plastic Tubing (Assembled)
- 05 Compression Fitting (Assembled)

06 Molded end (Bulb)

07 Compression nut (1/4") (Not supplied)

08 Plastic Tubing (Not supplied)

NOTE: If you have to relocate the refrigerator after connecting the water line (C), make sure the joined section of the water line is straight.

1. Connect the household water line to the assembled compression fitting.

- If you are using copper tubing, slip the compression nut (07) (not supplied) and ferrule (not supplied) on the copper tubing (not supplied) as shown.
- If you are using plastic tubing (08), insert the molded end (Bulb) of the plastic tubing (08) into the compression fitting.

2. Tighten the compression nut (07) onto the compression fitting. Do not over-tighten the compression nut (07).

3. Turn the water on and check for any leakage. If you find water drops or leakage in the connection areas, turn off the main water supply. Check the connections and, if necessary, tighten.

4. Flush 1 gallon of water through the filter before drinking or using the water from the refrigerator. (Flush approximately 6 minutes.) To flush, press a large glass or cup against the water dispenser lever. Fill the glass, empty it, and then repeat.

5. After you turn on the refrigerator, let the ice maker make ice for 1 to 2 days. Over that period of time, throw out the first 1 or 2 buckets of ice the ice maker makes to ensure all impurities have been removed from the water line.

STEP 7 Initial settings

By completing the following steps, the refrigerator should be fully functioning.

1. Plug the power cord into the wall socket to turn the refrigerator on.
2. Open the door, and check if the interior light lights up.
3. Set the temperature to the coldest setting, and wait for about an hour. Then, the freezer will be slightly chilled, and the motor should be running smoothly.
4. Wait until the refrigerator reaches the set temperature. Now the refrigerator is ready for use.

STEP 8 Final check

When installation is complete, confirm that:



- The refrigerator is plugged into an electrical outlet and grounded properly.
- The refrigerator is installed on a flat, level surface with a reasonable clearance from walls and cabinets.

- The refrigerator is level and is sitting firmly on the floor.
- The door opens and closes freely, and the interior light turns on automatically when you open the door.

Operations

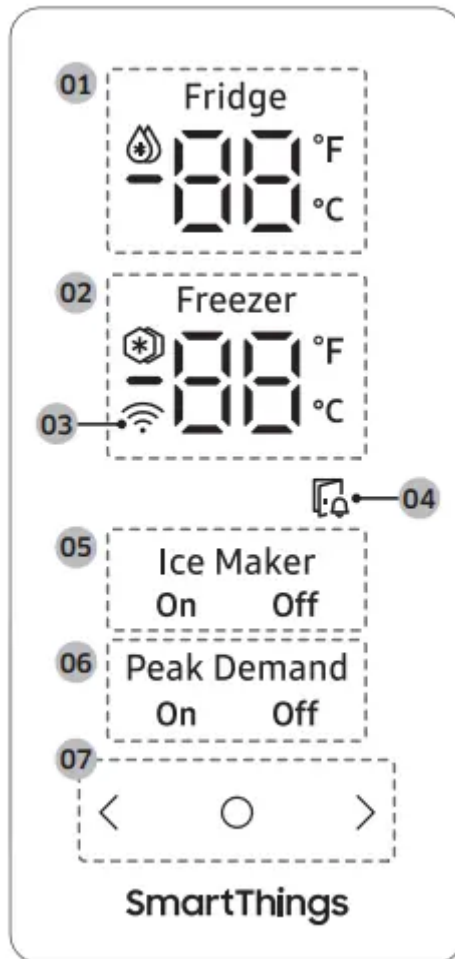
Main panel



1. **Fridge indicator** - Displays the current or desired temperature of the fridge.  indicates that the Power Cool function is on.
2. **Freezer indicator** - Displays the current or desired temperature of the freezer.  indicates that the Power Freeze function is on.
3. **Network connection indicator *** - This icon indicates that the refrigerator is connected to a network. You can control and monitor your refrigerator on the SmartThings app. For more information, see the **SmartThings** section.
4. **Door open indicator** - This indicator blinks with an alarm if the door is left open for more than 2 minutes.

5. Ice Maker indicator - Displays the status of the ice maker. To enable ice making, you must turn on the ice maker.
6. Peak Demand indicator * - Displays the status of the Peak Demand function. For more information on the Peak Demand function, see the **SMART GRID Function (Demand Response) (applicable models only)** section.
7. Buttons - When the display is off, tap any button to wake up the display. Tap O to select the desired item on the main panel and to confirm any setting changes. Tap < or > to change the settings of the selected item on the main panel.

* applicable models only

Setting the desired temperature or function



Select the fridge or freezer and set the desired temperature or function of your choice.

1 Tap any button (<, O, or >) to wake up the display. This step may not apply to some models.



2 Tap O until the fridge or freezer indicator blinks. The selected compartment's indicator blinks.

3 Tap < or > to select the desired temperature or function. Refer to the table for available selection for each compartment

Fridge

- Available selection (Fahrenheit):  (Power Cool) ↔ 34 °F ↔ 35 °F ↔ 36 °F ↔ 37 °F ↔ 38 °F ↔ 39 °F ↔ 40 °F ↔ 41 °F ↔ 42 °F ↔ 43 °F ↔ 44 °F
- Available selection (Celsius):  (Power Cool) ↔ 1 °C ↔ 2 °C ↔ 3 °C ↔ 4 °C ↔ 5 °C ↔ 6 °C ↔ 7 °C
- Power Cool speeds up the cooling process at maximum fan speed. The fridge keeps running at full speed for two and a half hours and then returns to the previous temperature.

Freezer

- Available selection (Fahrenheit):  (Power Freeze) ↔ -8 °F ↔ -7 °F ↔ -6 °F ↔ -5 °F ↔ -4 °F ↔ -3 °F ↔ -2 °F ↔ -1 °F ↔ 0 °F ↔ 1 °F ↔ 2 °F ↔ 3 °F ↔ 4 °F ↔ 5 °F
- Available selection (Celsius):  (Power Freeze) ↔ -23 °C ↔ -22 °C ↔ -21 °C ↔ -20 °C ↔ -19 °C ↔ -18 °C ↔ -17 °C ↔ -16 °C ↔ -15 °C
- Power Freeze speeds up the freezing process at maximum fan speed.

- The freezer keeps running at full speed for 50 hours and then returns to the previous temperature. To freeze large amounts of food, activate Power Freeze for at least 20 hours before putting food in the freezer.

4. Wait for 5 seconds or tap **O** to confirm your selection. The selected compartment's indicator stops blinking.

Changing the temperature scale

You can switch the temperature scale between Fahrenheit and Celsius.

1. Tap any button (<, **O**, or >) to wake up the display. This step may not apply to some models.
2. Tap **O** until the °F and °C symbols on the fridge or freezer blink.
3. Tap < or > to select the desired temperature scale. Tap < to select Fahrenheit. Tap > to select Celsius.
4. Wait for 5 seconds or tap **O** to confirm your selection. The °F and °C symbols stop blinking.

Turning on or off the ice maker

You can turn on or off the auto ice maker in the freezer.

1. Tap any button (<, **O**, or >) to wake up the display. This step may not apply to some models.
2. Tap **O** until the Ice Maker indicator blinks.
3. Tap or to turn on or off the ice maker. Tap < to turn it on. Tap > to turn it off.
4. Wait for 5 seconds or tap **O** to confirm your selection. The Ice Maker indicator stops blinking.

Turning on or off the Peak Demand function

You can turn on or off the Peak Demand function. For more information on the Peak Demand function, see the **SMART GRID Function (Demand Response) (applicable models only)** section.

1. Tap any button (<, **O**, or >) to wake up the display. This step may not apply to some models.
2. Tap **O** until the Peak Demand indicator blinks.
3. Tap < or > to turn on or off the function. Tap < to turn it on. Tap > to turn it off.
4. Wait for 5 seconds or tap **O** to confirm your selection. The Peak Demand indicator stops blinking.

Activating or deactivating the Sabbath mode

The Sabbath mode stays active for 85 hours once it is activated. After that, it will be deactivated automatically.

- To activate or deactivate the Sabbath Mode, tap and hold **O** and **>** simultaneously for 6 seconds. Then, when the display blinks, tap **>**. When the refrigerator is in the Sabbath mode, the buttons, display, and internal lights do not function. The refrigerator and freezer, however, continue to cool.

Activating or deactivating the Cooling Off mode

The Cooling Off mode (also called the Shop mode) is designed for retailers to display refrigerators on a retail floor. In the Cooling Off mode, the refrigerator's fan motor and lights operate normally, but the compressors do not run, so neither the refrigerator nor the freezer becomes cold.

- To activate or deactivate the Cooling Off mode, tap and hold **<** and **>** simultaneously for 6 seconds. Then, when the display blinks, press **O**. - When the Cooling Off mode is on, the refrigerator chime sounds, and the refrigerator shows **"0"** on the fridge indicator and **"FF"** on the freezer indicator.

SmartThings

Installation

Visit the Google Play Store, Galaxy Store, or Apple App Store and search for "SmartThings". Download and install the SmartThings app provided by Samsung Electronics to your smart device.

NOTE

- The SmartThings app is not available for some tablet and iPad and some smartphone.
 - Support that [Android] OS 6.0 or higher. (mimimum 2 GB RAM Size) - Support that [iOS] 10.0 or higher/iPhone 6 or higher.
- For improved performance, the SmartThings app is subject to change without notice or discontinued support according to the manufacturer's policy. • Recommended encryption systems include WPA/TKIP and WPA2/AES. Any newer or non-standard Wi-Fi authentication protocols are not supported.
- In addition, further updates on the app or the function in the app may stop due to usability and security reasons, even if updates are currently supported on your OS.
- Wireless networks may be affected by the surrounding wireless communication environment.
- If your Internet service provider has registered the MAC address of your PC or modem for identification, your Samsung Smart Refrigerator may fail to connect to the Internet. If this happens, contact your Internet service provider for technical assistance.

- The firewall settings of your network system may prevent your Samsung Smart Refrigerator from accessing the Internet. Contact your Internet service provider for technical assistance. If this symptom continues, contact a local Samsung service center or retailer.
- To configure the wireless access point (AP) settings, see the user manual of the AP (router).
- Samsung Smart Refrigerators support both IEEE 802.11 b/g/n (2.4 GHz) and 802.11 a/n/ac (5 GHz) protocols. (IEEE 802.11 n and 802.11 ac are recommended.)
- Unauthorized Wi-Fi wireless routers may fail to connect to applicable Samsung Smart Refrigerators.

Samsung account

You are required to register your Samsung account to use the app. If you don't have a Samsung account, follow the app's onscreen instructions to create a free Samsung account.

Getting started

Turn on the device you want to connect, open the SmartThings app on your phone, and then follow the instructions below. If a pop-up appears saying that a new device has been found, tap **ADD NOW**.

If a pop-up doesn't appear, tap the **+** button, and then select the device you want to connect from the list of available devices.

If your device isn't in the list of available devices, tap **Supported Devices**, select the device type (Refrigerator), and then select the specific device model.

Follow the instructions in the app to set up your device. Once setup is complete, your refrigerator will appear as a "card" on your **Devices** screen.

Refrigerator app

Integrated control: You can monitor and control your refrigerator at home and on the go.

- Tap the refrigerator icon on the SmartThings Dashboard or tap the Devices icon at the bottom of the Dashboard, and then tap the refrigerator "card" to open the Refrigerator page.
- Check the operation status or notifications related to your refrigerator, and then change options or settings if necessary

Refrigerator settings (Category > Item > Description)

Monitoring

- Fridge temperature
 - Displays the desired temperature setting of the fridge.

- Freezer temperature
 - Displays the current temperature of the freezer.
- Diagnosis
 - Detects abnormal operations of the refrigerator.
- Energy monitoring
 - Checks the accumulated power consumption of the refrigerator for the last 180 days.

Functions

- Ice making
 - You can turn the ice making function on or off, and check the current settings of the function.
 - You can also check the status and progress of ice making.
- Power Cool
 - You can turn Power Cool on or off, and check the current settings.
- Power Freeze
 - You can turn Power Freeze on or off, and check the current settings.
- Fridge temperature
 - You can set the desired temperature of the fridge.
- Freezer temperature
 - You can set the desired temperature of the freezer.
- Sabbath Mode
 - You can activate and deactivate the Sabbath mode.

Alarms

- Alarms Abnormally high temperature
 - This alarm is triggered when the fridge or the freezer has abnormally high temperatures.
- Door opening
 - This alarm is triggered if the fridge door or the freezer drawer is open for a specific time.

Special features

Ice maker

The refrigerator has a built-in ice maker that automatically dispenses ice so that you can enjoy filtered water with cubed or crushed ice.

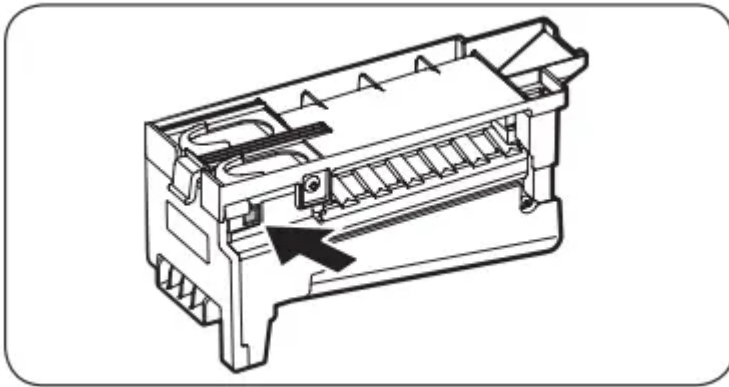

Ice Maker Operation

- The ice maker will produce 8 cubes per cycle - approximately 100~130 cubes in a 24-hour period, depending on freezer compartment temperature, room temperature, number of door openings, and other use conditions.
- Throw away the first few batches of ice to allow the water line to clear.
- Be sure nothing interferes with the sweep of the feeler arm. When the bin fills to the level of the feeler arm, the ice maker will stop producing ice.
- After the ice maker has been turned on again, there will be a time delay before the ice maker resumes operation.
- It is normal for several cubes to be joined together.
- If ice is not used frequently, old ice cubes will become cloudy, taste stale, and shrink. If you do not want to make ice, turn the ice maker off. (For detailed instructions on turning the ice maker on or off, see the “Turning on or off the ice maker” section.)

If You Turn the Ice Maker Off: If you turn the ice maker off, make sure to remove all ice cubes from the ice bucket. The remaining ice cubes may clump together, making it difficult to remove.

Maintenance

Handling and care:

Shelves

Fridge shelves

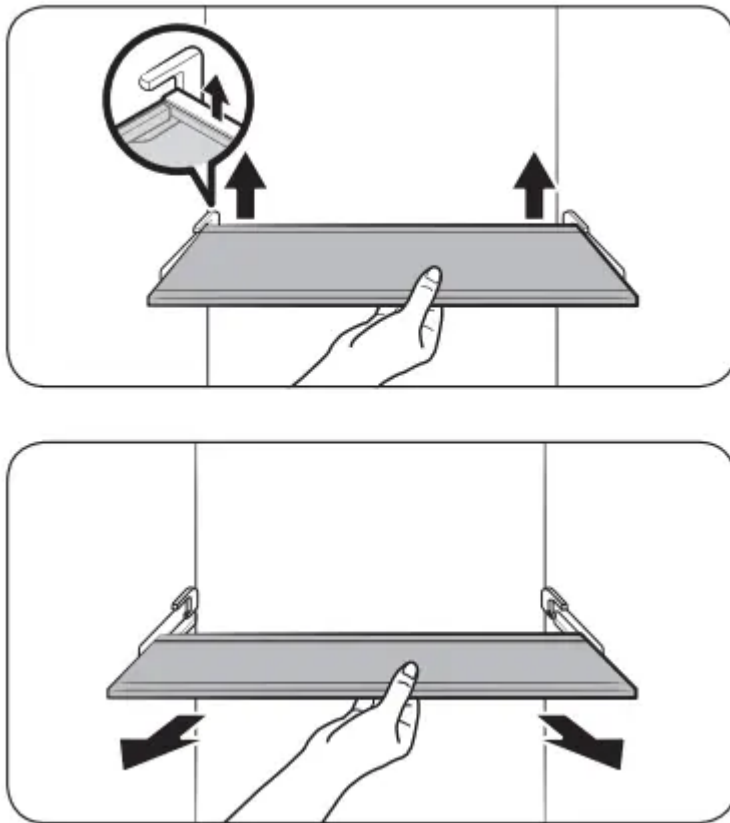

To remove a shelf, fully open the fridge door. Hold the front of the shelf and gently lift up and slide out.

1. Fully open the fridge door.
2. Hold the front of the shelf lift the back of the shelf to release the hook from the groove.
3. Pull out to remove.

Vegetable shelves

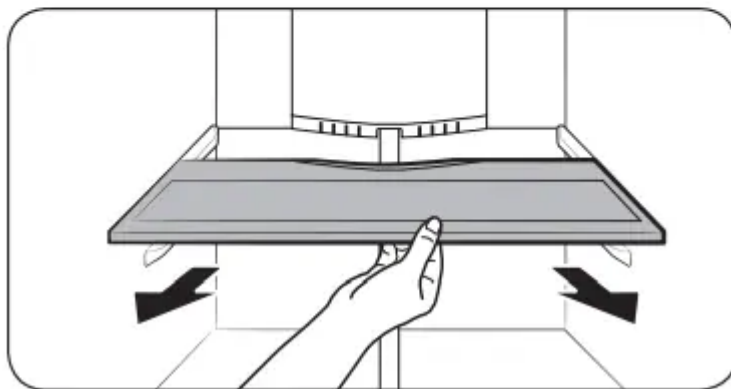
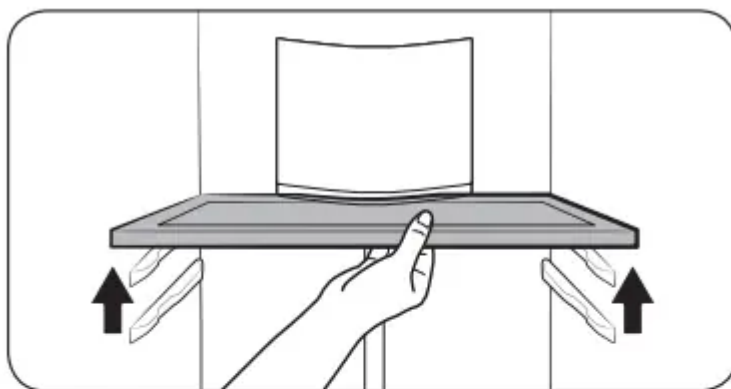

1. Fully open the fridge door.
2. Lift up the front of the shelf and pull it to release the shelf from the holder at the rear wall.
3. Pull out to remove.

Door bins

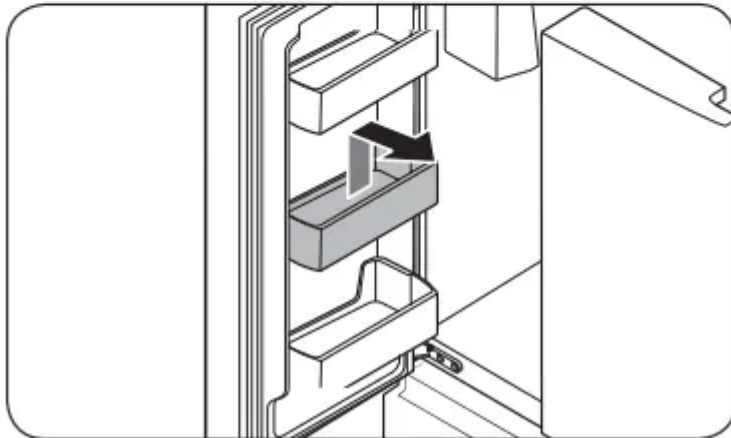
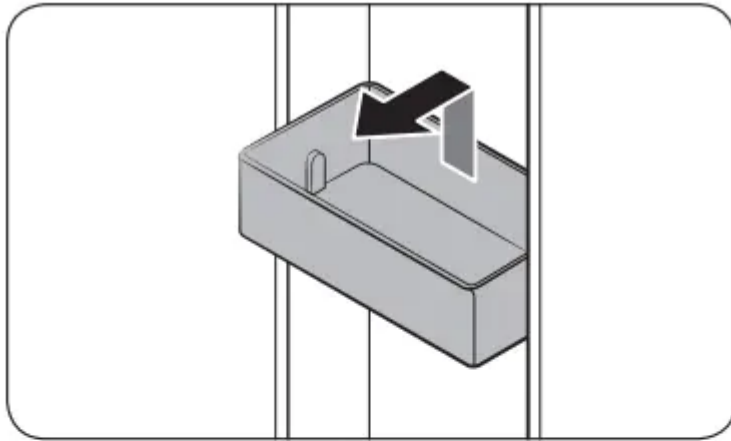

- To remove the door bin, hold the front sides of the bin, and then gently lift up to remove.
- To reinsert, insert the door bin slightly above its final location making sure that the back of the bin is against the door. Hold the rear of the door bin with both hands, and then press down so that it fits snugly

CAUTION

- Do not remove a bin that is filled with food. Empty the bin beforehand.
- Use caution when opening the door if the bottom bin contains larger bottles, which may fall over.
- Do not allow children to play with the bins. Sharp corners of the bin may cause injury

Fridge drawers

Vegetable / fruit drawers

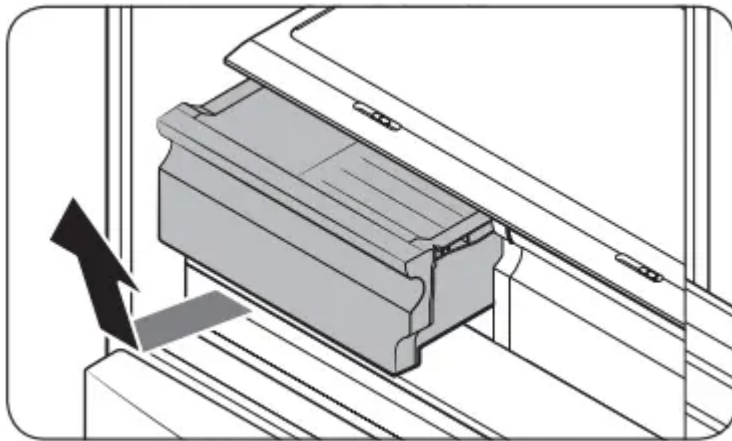

Gently lift up the front of the drawer and slide out.

- We recommend that you remove the door bins before removing the drawer. This is to prevent damage to the door bins.
- To reinsert, insert the drawer into the frame rails and then slide inward.

Freezer baskets

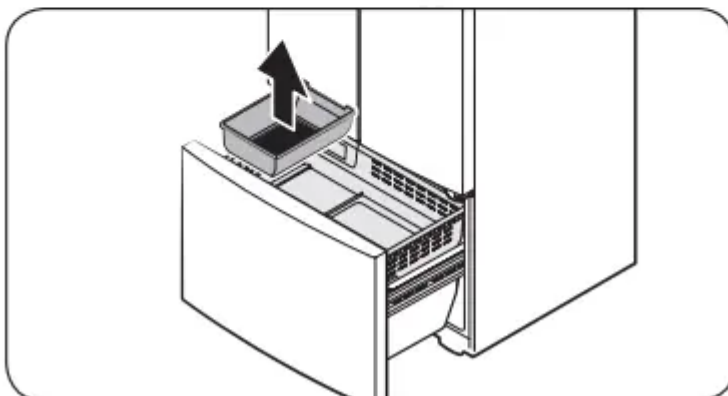
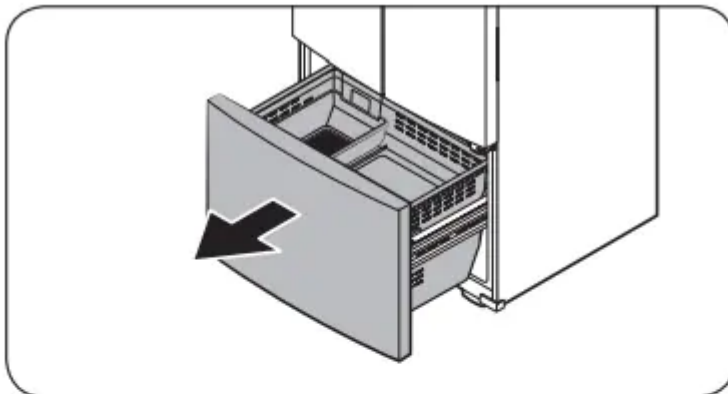

1. Fully open the freezer drawer.
2. Lift the ice bucket to remove.

Upper basket

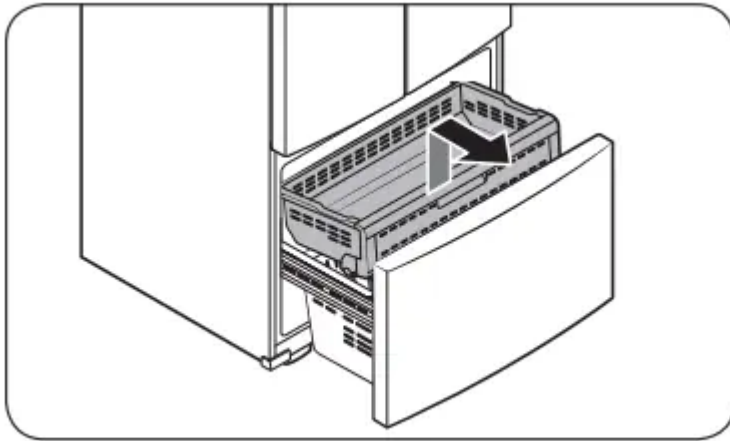

- To remove, fully slide open the freezer drawer. Lift up the front of the upper basket and pull to remove.
- To reinsert, align the front wheels of the upper basket with the end of the lower basket. Slide the upper basket to the front.

Lower basket

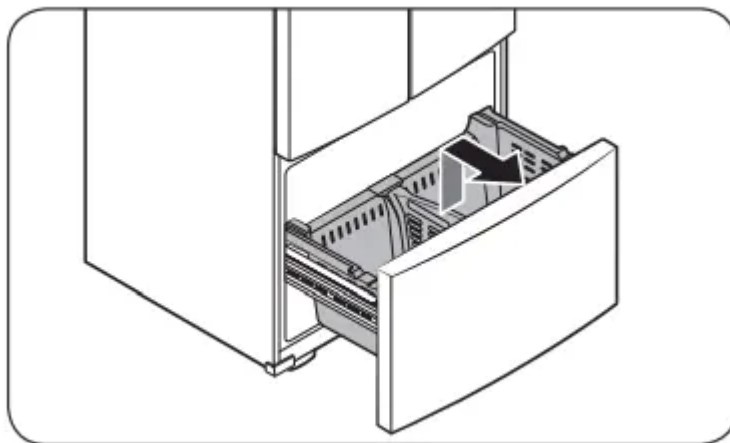

- To remove, first remove the upper basket. Then, tilt up the front of the lower basket to pull out.
- To reinsert, put the basket onto the rail assembly rear side first.

Cleaning

Interior and exterior

Regularly use a dry cloth to remove all foreign substances such as dust or water from the power plug terminals and contact points.

1. Unplug the power cord.
2. Use a moistened, soft, lint-free cloth or paper towel to clean the refrigerator's interior and exterior.

3. When done, use a dry cloth or paper towel to dry well.

4. Plug in the power cord.

Rubber seals

If the rubber seals of a door become dirty, the door may not close properly and reducing refrigerator performance and efficiency. Use a mild detergent and damp cloth to clean the rubber seals. Then, dry well with a cloth.

Rear panel

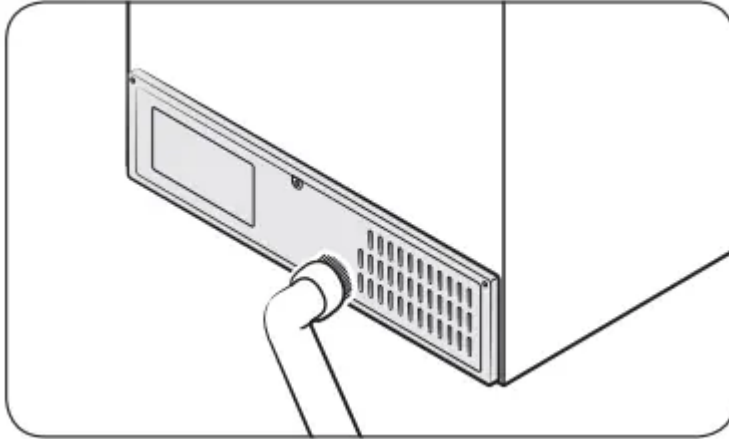

To keep cords and exposed parts of the rear panel free of dirt, vacuum the panel once or twice a year.

Replacement

LED Lamps

To replace the lamps of the refrigerator, contact a local Samsung service center.

WARNING

- The lamps are not user-serviceable. Do not attempt to replace a lamp yourself. This can cause electric shock.

Troubleshooting

Temperature

Fridge/freezer does not operate. Fridge/freezer temperature is warm.

Possible causes:

- Power cord is not plugged in properly.
- Temperature control is not set correctly.
- Refrigerator is located near a heat source or direct sunlight.

- Not enough clearance between refrigerator and nearby walls or cabinets.
- The refrigerator is overloaded. Food is blocking the refrigerator vents.

Solution:

- Properly plug in the power cord.
- Set the temperature lower.
- Keep the refrigerator away from direct sunlight or a heat source.
- Make sure there is a gap of at least 2.5 inches (5 cm) between the refrigerator back and sides and any nearby walls or cabinets.
- Do not overload the refrigerator. Do not allow food to block vents.

Fridge/freezer is over-cooling.

Possible causes:

- Temperature control is not set correctly.

Solution:

- Set the temperature higher.

Interior wall is hot.

Possible causes:

- Refrigerator has heat-proof piping in the interior wall.

Solution:

- To prevent condensation from forming, the refrigerator has heat-proof piping in the front corners. If the ambient temperature rises, this equipment may not work effectively. This is

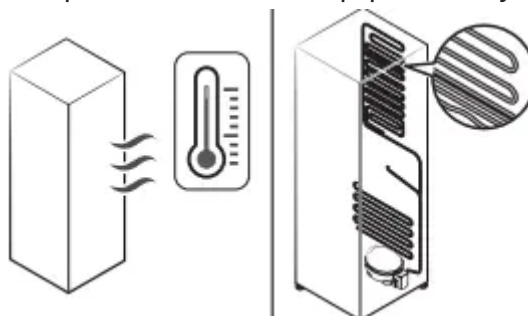

not a system failure.

Odors

Refrigerator has odors.

Possible causes:

- Spoiled food.
- Food with strong odors.

Solution:

- Clean the refrigerator and remove any spoiled food.
- Make sure strong smelling food is wrapped airtight.

Frost

Frost around the vents.

Possible causes:

- Food is blocking the vents.

Solution:

- Make sure no food blocks the refrigerator vents.

Frost on interior walls.

Possible causes:

- Door is not closed properly.

Solution:

- Make sure food does not block the door. Clean the door gasket.

Condensation

Condensation forms on the interior walls.

Possible causes:

- If door is left open, moisture enters the refrigerator.
- Food with high moisture content.

Solution:

- Remove the moisture and do not leave a door open for extended periods of time.
- Make sure food is wrapped airtight.

Water/ice (dispenser models only)

Water flow is weaker than normal.

Possible causes:

- Water pressure is too low.

Solution

- Make sure the water pressure is between 30 to 120 psi (206 to 827 kPa).

Ice maker makes a buzzing sound.

Possible causes:

- The Ice Maker function is activated, but the water supply to the refrigerator has not been connected.

Solution

- Press Ice Maker.

Ice maker does not make ice.

Possible causes:

- Ice maker has just been installed.
- Freezer temperature is too high.
- Dispenser panel Lock is activated.
- Ice maker is off.

Solution:

- You must wait for 12 hours for the refrigerator to make ice.
- Set the freezer temperature below 0 °F (-18 °C) or -4 °F (-20 °C) in warm ambient air.
- Deactivate dispenser panel Lock.
- Turn on the ice maker.

Ice does not dispense.

Possible causes:

- Ice may jam if the ice dispenser is not used for a long time (approx. 3 weeks).
- Ice bucket is not properly inserted.
- Water line is not connected properly or water supply is not on.

Solution:

- If you won't be using the refrigerator for a long time, empty the ice bucket and turn off the ice maker.
- Make sure the ice bucket is properly inserted.
- Check if the water line is installed correctly. Check if the water line stop cock is closed.

Water does not dispense.

Possible causes:

- Water line is not connected properly or water supply is not on.
- Dispenser panel Lock is activated.
- A third-party water filter was installed.
- Water filter indicator turns on or blinks.

Solution:

- Check if the water line is installed correctly. Check if the water line stop cock is closed.

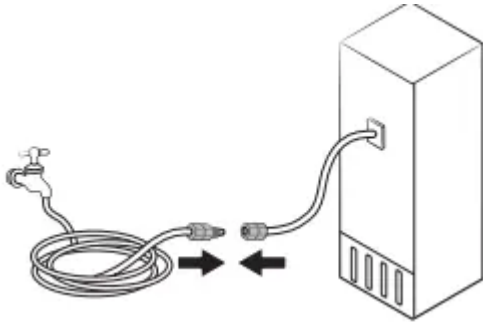

- Deactivate dispenser panel Lock.
- Use only Samsung-provided or approved filters.
- Unapproved filters may leak and damage the refrigerator.
- Replace the water filter. After replacing, reset the filter indicator sensor.

Do you hear abnormal sounds from the refrigerator?

These sounds are normal.

- When starting or ending an operation, the refrigerator may make sounds similar to a car engine ignition. As the operation stabilizes, the sounds will decrease.

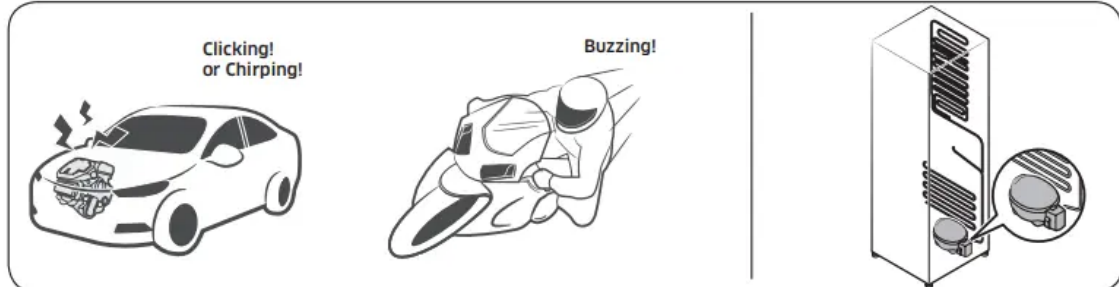

- While the fan is operating, these sounds may occur. When the refrigerator reaches the set temperature, the fan sound will stop.

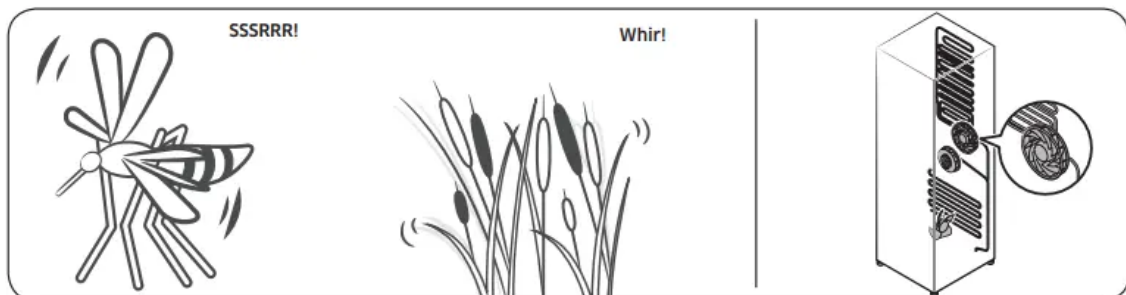

- During a defrost cycle, water may drip on the defrost heater, causing sizzling sounds.

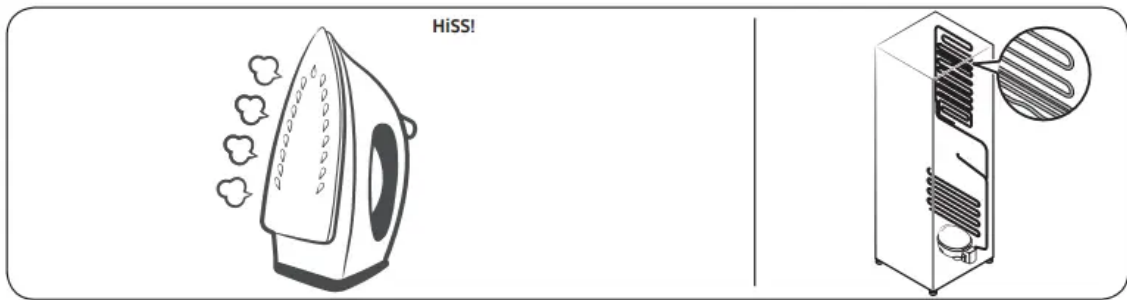

- As the refrigerator cools or freezes, refrigerant gas moves through sealed pipes, causing bubbling sounds.

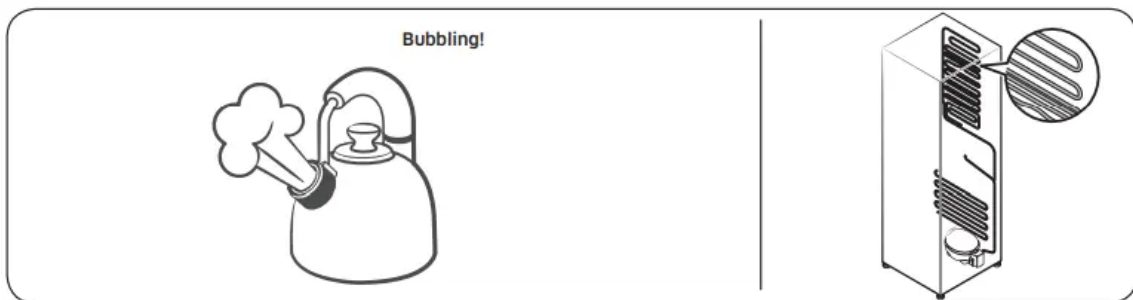

- As the refrigerator temperature increases or decreases, plastic parts contract and expand, creating knocking noises. These noises occur during the defrosting cycle or when electronic parts are working.

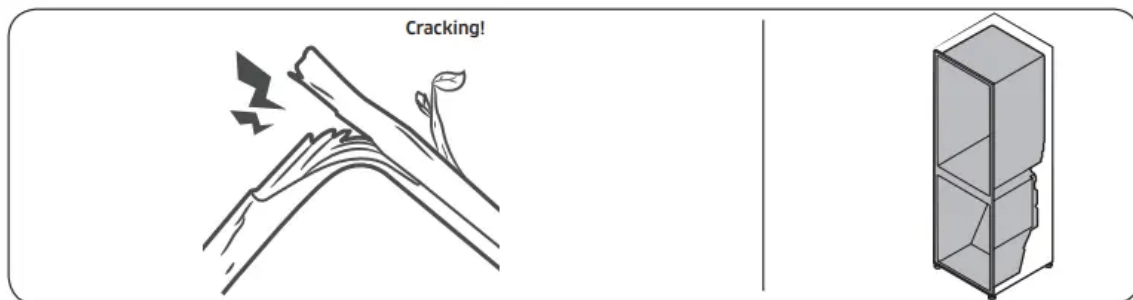

- For ice maker models: When the water valve opens to fill the ice maker, you may hear a buzzing sound.
- Due to pressure equalizing when you open and close the refrigerator door, you may hear a whooshing sound.

SmartThings (Symptom > Action)

Could not find “SmartThings” in the app market.

- The SmartThings app is not available for some tablet and iPad and some smartphone.
 - support that [Android] OS 6.0 or higher (minimum 2GB RAM Size)
 - support that [iOS]10.0 or higher/iPhone6 or higher.

The SmartThings app fails to operate.

- The SmartThings app is available for applicable models only.
- The old Samsung Smart Refrigerator app cannot connect with Samsung Smart Home models.

The SmartThings app is installed but is not connected to my refrigerator.

- You must log into your Samsung account to use the app.
- Make sure that your router is operating normally.
- If the Wi-Fi icon on the refrigerator's display is off, this indicates that no network connection has been established yet. In this case, use the SmartThings app to connect and register your refrigerator to the access point (AP) of your house.

Could not log into the app.

- You must log into your Samsung account to use the app.
- If you don't have a Samsung account, follow the app's onscreen instructions to create one

. An error message appears when I try to register my refrigerator.

- Easy Connection may fail due to the distance from your access point (AP) or electrical interference from the surrounding environment. Wait a moment and try again.

The SmartThings app is successfully connected to my refrigerator but does not run.

- Exit and restart the SmartThings app, or disconnect and reconnect the router.
- Power off the refrigerator, and then power it on again after 1 minute.

Smart Grid (applicable models only) (Symptom > Action)

What Do I Need to use the Energy Management and Smart Grid functions?

- To use the Smart Grid (Demand Response) and Energy Management function on your Refrigerator, you need the following devices and apps:
 - Devices: 1) A Wireless Router, 2) A SmartThings Refrigerator, 3) A Smartphone. (Recommended: Android OS 6.0 or later version)
 - Applications: 1) "SmartThings App" from the Google Play Store.

You also need to:

- Connect the Refrigerator and the Smartphone to the same Wi-Fi network in your home.
- Install and run the SmartThings App on your Smartphone.
- In addition, to use the Smart Grid (Demand Response) function, you must Register for the service with your electric company. The company must have an EMS (Energy Management System) that supports SEP (Smart Energy profile).

Why isn't the Energy Management function working normally?

- Confirm that the router in your home and the internet are working properly.
 - Connect a Smartphone to the router (AP, Access Point), and then confirm that you can browse the Internet on the phone.
- Confirm that refrigerator is connected to the AP.
 - Check for Wi-Fi icon on the panel of the refrigerator. If the refrigerator is connected, the icon will be on.
- Confirm that the refrigerator and Smartphone are connected to the same router.

Why isn't the Delay Defrost Capability working normally?

- Confirm that the router in your home and the Internet are working properly.
- Connect a Smartphone to the router (AP, Access Point), and then confirm that you can browse the Internet on the phone.
- Confirm that the rear where you live is properly entered into the SmartThings App.
- Confirm that the Smart Grid function works correctly. (Check the control panel. The DAL or TALR icon should not be displayed on the panel.)

Warning

This content is compiled from multiple sources and is provided for reference purposes only. It may not be complete or fully applicable to all situations. If you are unable to resolve your issue, please contact the product manufacturer or an authorized service provider for official support.