

CLASSIC FEATURES

FEATURES

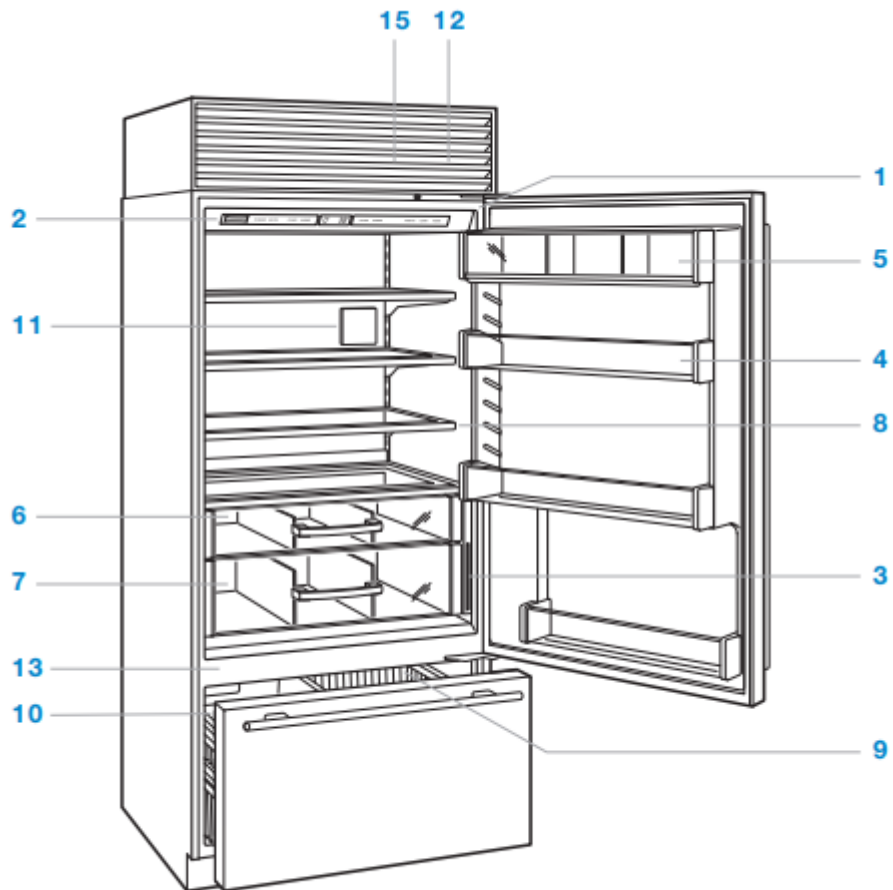

Over-and-under model



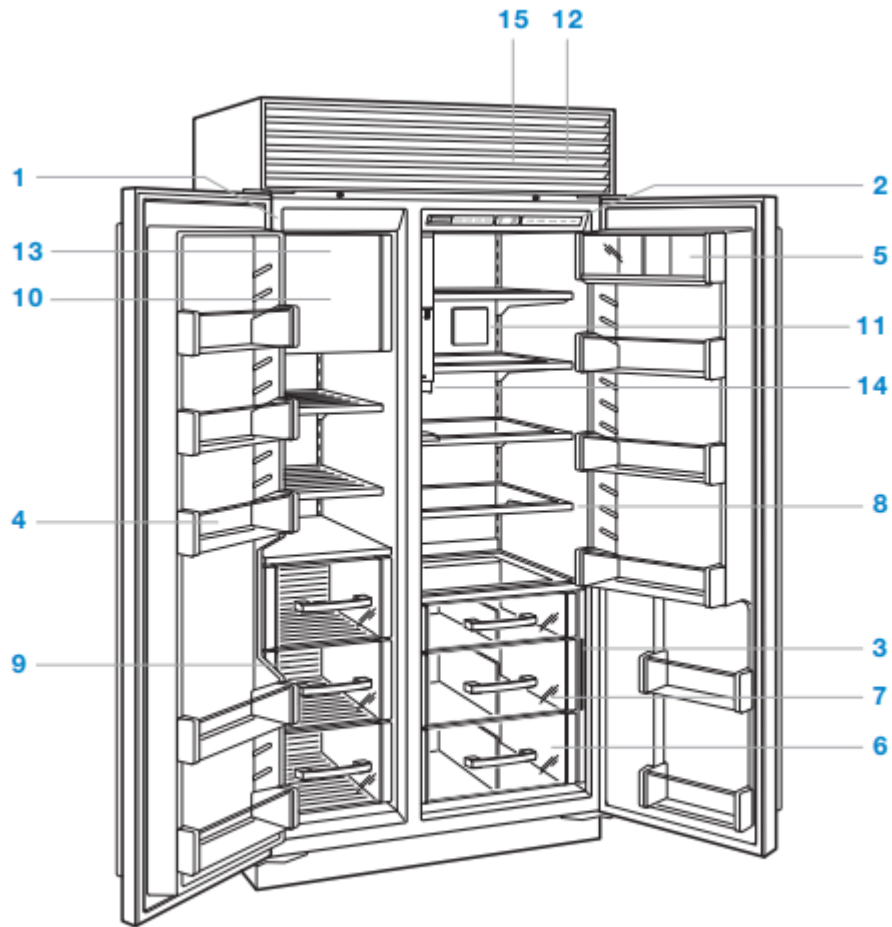

Side-by-side model with internal dispenser

1. Product Rating Plate
2. Electronic Control Panel and Display
3. Freshness Cards
4. Door Shelves
5. Dairy Compartment
6. Refrigerator Storage Drawers
7. High-Humidity Crisper Drawer
8. Glass Shelves
9. Freezer Baskets
10. Ice Container
11. Air Purification System
12. Water Filtration System (behind grille)
13. Automatic Ice Maker

14. Ice and Water Dispenser (dispenser models)

15. Condenser (behind grille)

Control Panel

FUNCTION

LIGHTS	Turns the interior accent lighting on or off for glass door models.
ICE MAKER	Turns power to the ice maker on or off. Use to disable the ice maker during extended vacations.
MAX ICE	Activates or deactivates the max ice feature which increases ice production 30% for a 24-hour period.
COLDER WARMER	Adjusts the temperature in one-degree increments. Combination units have separate temperature controls for the refrigerator and freezer. Temperatures are preset at 38°F (3°C) and 0°F (-18°C).
PURE AIR	Activates or deactivates the air purification system.
ALARM	Activates or deactivates the door alarm. A chime indicates the door has been left ajar for more than 60 seconds.
POWER	Turns the unit on or off. When the power is off, "OFF" appears in the control panel display. Turning the power off at the control panel eliminates the need to unplug or turn the power off at the circuit breaker during service or extended vacations.

INDICATOR



Illuminates or flashes when the electronic control system detects a temperature or ice maker problem, or if the condenser needs to be cleaned.



Illuminates when the air purification system is activated, and flashes when the cartridge needs to be replaced. After the cartridge has been replaced, touch and hold PURE AIR on the control panel for 5 seconds to reset.



Illuminates when the water filter needs to be replaced.



Illuminates when the ice maker system is activated.



Illuminates when the max ice feature is activated.



Illuminates when the door alarm is activated.



Illuminates when the accent lighting is activated for glass door models.



Control panel and display (model BI-30UG shown)

STORAGE

Keeping Food At Its Best

DUAL REFRIGERATION®

This Sub-Zero features a unique Dual Refrigeration® system to keep food fresher longer.

With the Sub-Zero Dual Refrigeration® system, individual refrigerator and freezer systems have been designed to maintain accurate, consistent temperatures and proper humidity levels for longer food life expectancy. Dual Refrigeration® eliminates transfer of fresh food odors to frozen food and ice and does not freeze the moisture out of the air in the fresh food section.

For handy tips and information on how to maximize food freshness, refer to the freshness cards stored in the refrigerator.

Refrigerator Storage

DOOR SHELVES

To remove a door shelf or the dairy compartment, lift from the bottom and slide out. To reinstall, place in the desired position and slide the shelf down onto the guides. Refer to the illustration below.

IMPORTANT NOTE: If the door opening is limited to 90°, door shelves may need to be removed before removing a storage drawer or glass shelf.

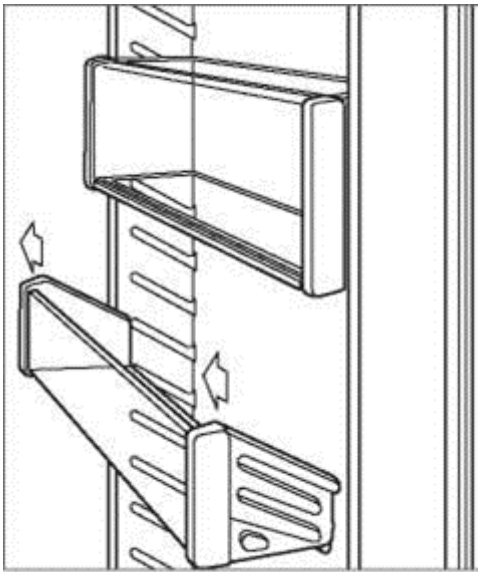

Door shelf removal

STORAGE DRAWERS

To remove a storage drawer, pull forward until the drawer stops. Lift the front of the drawer slightly, then pull forward. Refer to the illustration below.

For French door models, the drawer slides may need to be pushed back manually to provide sufficient clearance for removal.

To reinstall, push the drawer slides in. Align the drawer with the slides and push back until it stops. Press down on the front of the drawer to engage the slides.

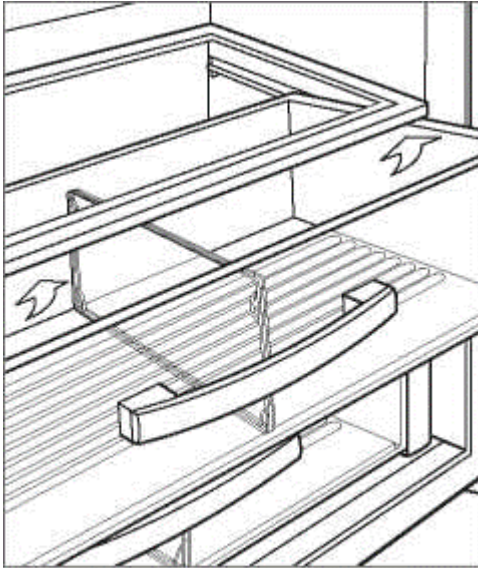

Storage drawer removal

GLASS SHELVES

To remove or adjust a glass shelf, tilt up, then lift up and out. To reposition, insert the shelf in the tracks along the back wall, then lower the front until it locks into position. Refer to the illustration below.

IMPORTANT NOTE: Use care when handling glass shelves to prevent breakage or scratching the interior.

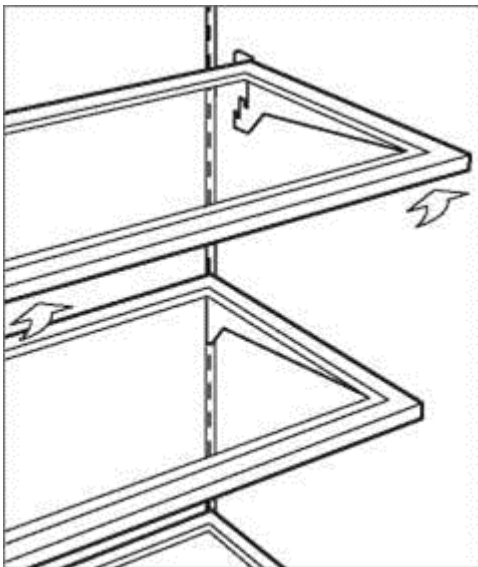

Glass shelf removal

Freezer Storage

FREEZER BASKETS

BI-36F and side-by-side models: To remove, pull forward until the basket stops. Pull the two metal clips located behind the bottom two corners of the basket forward, then lift up and out. Refer to the illustration below. To reinstall, push the drawer slides in. Align the basket with the slides and push back until it stops. Press down on the front of the basket to engage the slides.

IMPORTANT NOTE: For models BI-36S, BI-42S, BI-42SID, and BI-42SD, to remove, the freezer basket must be raised and pulled through the opening in the door liner after disengaging.

Over-and-under models: To remove the upper and lower freezer baskets, lift up and out. Refer to the illustration below. To reinstall, insert the lower basket into the four corner retainers. Position the upper basket onto the side rails and slide back until it clicks.

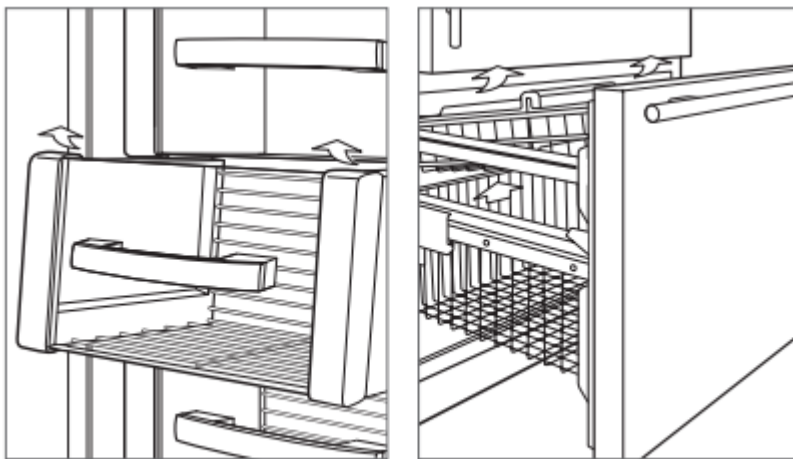

BI-36F and side-by-side models Over-and-under models

ICE CONTAINER

BI-36F and over-and-under models: To remove, pull the container forward until it stops, then lift out.

Side-by-side models: To remove, pull the container forward until it stops, then lift to clear the carrier assembly along the back. Pull forward and out. Refer to the illustration below.

Dispenser models: To remove, pull the container out partially, then rotate and pull out. Refer to the illustration below.

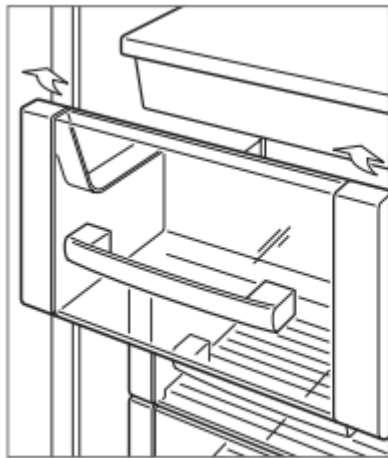

Side-by-side models

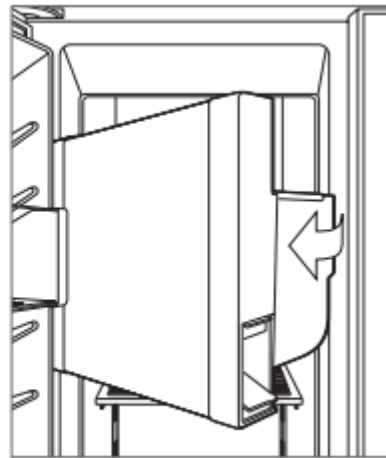

Dispenser models

OPERATION

Air Purification System

Many fresh foods emit ethylene gas, a naturally-occurring compound that hastens food ripening and spoilage. The air purification cartridge has been factory installed and is located inside the refrigerator, on the back wall.

To initiate air purification, touch PURE AIR on the control panel.

The cartridge will last approximately one year. The indicator will flash in the control panel display when the cartridge needs to be replaced.

Replacement Sub-Zero air purification cartridges can be ordered online at subzero.com/store. For questions, contact Sub-Zero Customer Care at 800-222-7820.

AIR PURIFICATION CARTRIDGE REPLACEMENT

1. To access the air purification cartridge, grasp the outside cover from the bottom and rotate upward. Refer to the illustration below.
2. Grasp the black cover from the top and rotate downward. The cartridge will pop out and can be removed.
3. Remove the new cartridge from packaging and insert with the connector pointing downward.
4. Once in position, close the black cover. Then rotate the outside cover downward until it closes against the back wall.
5. Once the cartridge has been replaced, touch and hold PURE AIR on the control panel for five seconds to reset. The  indicator will appear in the control panel display but not flash.

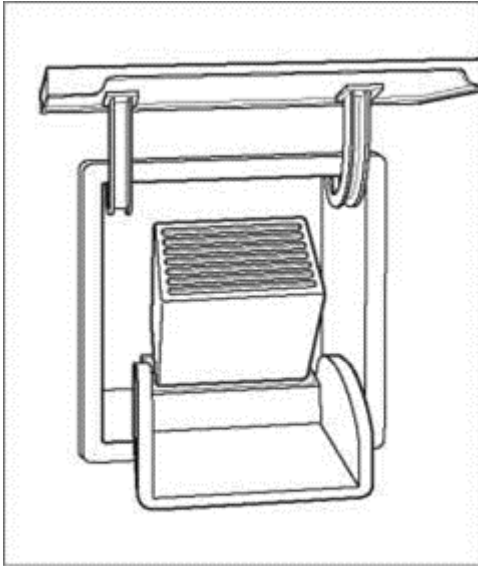

Air purification cartridge

Water Filtration System

The water filtration system of Sub-Zero Classic models supplies filtered water to the ice maker and water dispenser (dispenser models) to produce great-tasting water and ice.

IMPORTANT NOTE: When using the water filtration system for the first time and after filter replacement, it is necessary to clear any air from the system and allow the filter to assist in cleaning the water lines. For non-dispenser models, discard the first two full containers of ice. For dispenser models, dispense several glasses of water for a period of two minutes.

If the water filtration system will not be used, it can be placed in water filter bypass mode by removing the filter.

The filter is rated for 750 gallons (2839 L) or one year, whichever comes first. The  indicator will illuminate in the control panel display when the filter needs to be replaced.

Replacement Sub-Zero water filters can be ordered online at subzero.com/store. For questions, contact Sub-Zero Customer Care at 800-222-7820.

WATER FILTER REPLACEMENT

1. To access the water filter, pull out on the bottom edge of the grille assembly and rotate upward.
2. To remove the old filter, rotate counterclockwise one-quarter turn, then pull out. Refer to the illustration below. It is normal for a small amount of water to drip when the filter is removed. It should be wiped up with a paper towel or cloth.
3. Remove the new filter from packaging and remove the plastic cap.
4. Insert the new filter into the manifold and turn clockwise.

5. Once the new filter has been installed, press and hold the water filter reset button for five seconds to reset. Refer to the illustration below.

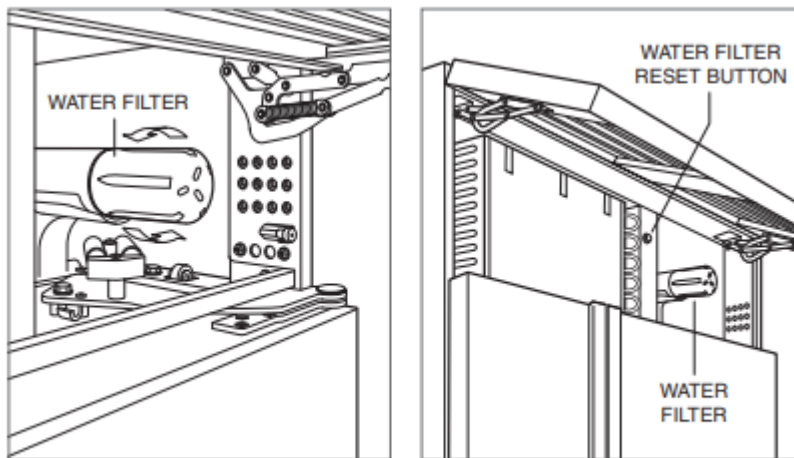

Water filter removal

Water filter location

Ice Maker Operation

To initiate ice production, touch ICE MAKER on the control panel. After initial start-up, discard the first few batches of ice. The ice may contain impurities from new plumbing connections.

The ice maker will cycle every two hours. If ice is not used regularly it may fuse together. To avoid, discard ice and allow ice maker to replenish.

Sabbath

This appliance is certified by Star-K to meet strict religious regulations in conjunction with specific instructions found on www.star-k.org.

To initiate Sabbath mode, while the unit is on, touch POWER on the control panel. "OFF" appears in the control panel display. Touch and hold POWER for 10 seconds until "SAb" appears in the display indicating Sabbath mode has been initiated. Lights, ice maker, door alarm, and dispenser (if applicable) will be disabled. To return to normal operating conditions, touch POWER.

Ice and Water Dispenser

The first time the water dispenser is used, purge the water system and storage tank for three minutes. This will clear any air in the system, along with impurities from new plumbing connections.

Initially, for water to dispense properly, press and hold WATER or the water dispenser button until water flows from the dispenser. It may need to be pressed for 60 seconds for water to fill the internal reservoir tank.

The chilled water reservoir tank holds approximately 40 oz (1.2 L) of filtered water. It may take several hours to chill the water to refrigerator temperature during the original fill and after a large amount of water is dispensed.

Ice and Water Dispenser

INTERNAL DISPENSER

For models BI-42SID and BI-48SID, the internal ice and water dispenser is designed to accommodate a 16-oz (.5 L) pint glass. Larger containers may be used but may compromise the effectiveness of the dispenser. Drops of water may collect in the removable water grille located directly below the dispenser. Refer to the illustration below.

FUNCTION

ICE	Press and hold to dispense ice.
------------	---------------------------------

WATER	Press and hold to dispense water.
--------------	-----------------------------------

For models with an internal water only dispenser, the dispenser is located inside the refrigerator on the left wall. Press a glass against the dispenser to activate water flow. Water flow will stop when the glass is pulled away. Refer to the illustration below.

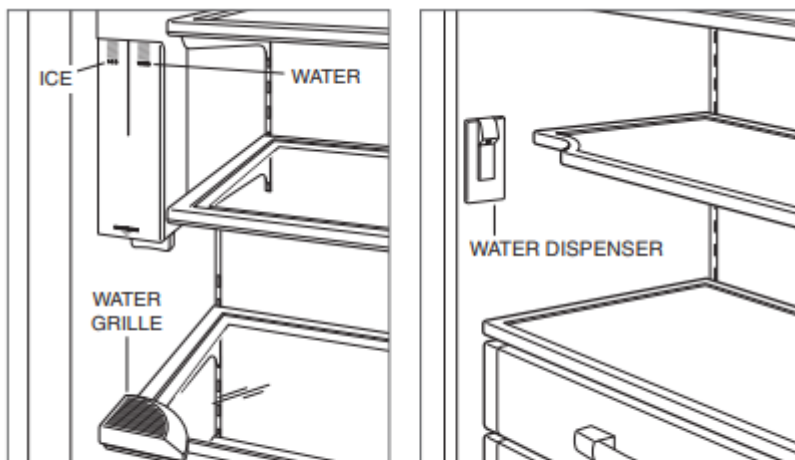

Internal ice and water dispenser

Internal water dispenser

EXTERNAL DISPENSER

Drops of water may collect in the removable water grille. This is not a drain. Do not pour water into the water grille. For large quantities of ice, a bulk ice dispenser is located inside the refrigerator. Refer to the illustrations below.

FUNCTION

LIGHT	Press to cycle through lighting options; lights off, lights on, and control panel lights only.
ICE	Press and hold to dispense ice.
WATER	Press and hold to dispense water.
LOCK	Press and hold for 3 seconds to activate or deactivate the dispenser lock. The lock indicator will be illuminated when dispenser is locked.
BULK ICE	Press and hold to dispense large quantities of ice.

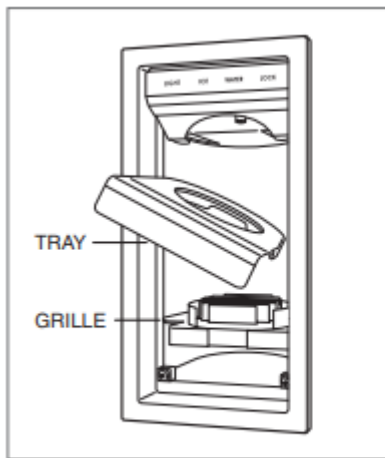

Removable water grille

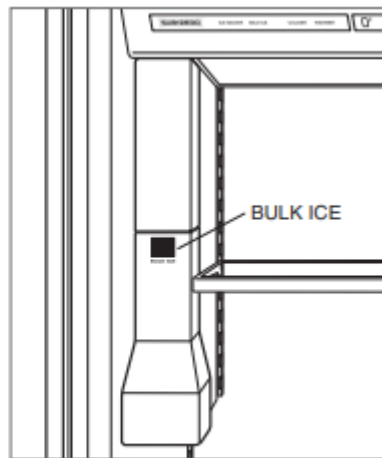

Bulk ice dispenser

CARE RECOMMENDATIONS

Interior Lighting

For glass door models, accent lighting can be turned on and off by touching LIGHTS on the control panel. The indicator illuminates when accent lighting is activated.

Cleaning

STAINLESS STEEL EXTERIOR

Use a nonabrasive stainless steel cleaner and apply with a soft lint-free cloth. To bring out the natural luster, lightly wipe the surface with a water-dampened microfiber cloth followed by a dry polishing chamois. Always follow the grain of stainless steel.

INTERIOR CLEANING

For over-and-under and side-by-side models, the refrigerator or freezer may be disabled without disrupting the other section. To disable a section, touch POWER. Touch and hold WARMER for the

section being disabled, continue to hold and touch POWER. Double dashes will appear in the control panel display. Repeat to turn the section back on.

To clean interior surfaces and all removable parts, wash with a mild solution of soap, water, and baking soda. Rinse and dry thoroughly. Avoid getting water on the lights and control panel.

VACATIONS

For extended vacations, turn power off at the control panel. Empty the unit and block doors open slightly to let fresh air in and keep the interior dry. The water filter should be replaced before start-up.

CONDENSER CLEANING

The condenser is located behind the flip-up grille. To access, pull out on the bottom edge of the grille and rotate upward. Use a soft bristle brush and vacuum to remove dust and lint from the condenser. Clean the condenser every 6-12 months. Refer to the illustration below.



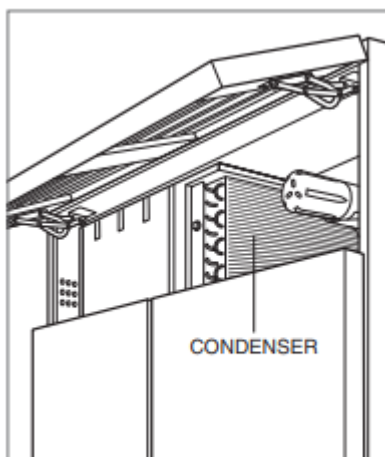

IMPORTANT NOTE: To avoid damaging the condenser fins, vacuum in the direction of the fins.



Condenser location

TROUBLESHOOTING

SERVICE INDICATOR

	<p>Indicator illuminated: Touch POWER to turn the unit off. Verify the condenser area is clean. Touch POWER to turn the unit on. If the indicator is still illuminated, call Sub-Zero Customer Care at 800-222-7820.</p>
	<p>Indicator flashing: Contact Sub-Zero Factory Certified Service.</p>
	<p>Indicator flashing with chime: Contact Sub-Zero Factory Certified Service.</p>
	<p>Indicator flashing: Replace the air purification cartridge. Also, replace the cartridge if there is an odor inside the unit.</p>
	<p>Indicator flashing: Replace the water filter. Also, replace the filter if the ice tastes bad, is discolored, ice cubes are small, or if the water flow from the dispenser is slow.</p>
	<p>Indicator flashing with chime: The door has been left ajar for more than 60 seconds. Close the door.</p>

UNIT OPERATION

No lights or cooling.

- Verify power is on.
- Verify electrical power to the unit and home circuit breaker is on.

No lights in the refrigerator or freezer

- The door/drawer may have been left ajar, which has disabled lights to eliminate excess heat. If the lights are out, close the door/drawer for one hour. If the lights are still out, contact Sub-Zero Factory Certified Service.
- LED interior lighting must be replaced by Sub-Zero Factory Certified Service.

Frost, condensation, or ice buildup inside the unit.

- Verify the condenser is clean.
- Verify the door is closing properly.
- Verify the door has not been left ajar.
- Verify the door gasket does not have rips or tears. If it does, contact Sub-Zero Factory Certified Service.
- If icing is heavy, turn the unit off and use a hair dryer to melt the ice. The hair dryer should be set on low and kept moving at all times. Once the ice has melted, wipe up any water with a cloth or paper towel.

High temperatures, the unit runs excessively or the unit is giving off too much heat.

- Verify the condenser is clean.
- Verify the door is closing properly.
- Verify the door has not been left ajar.
- Increased ambient temperatures may cause the compressors to run longer
- If the temperature display shows 38° and 0°, but is not cooling, the unit may be in showroom mode. Contact Sub-Zero Customer Care at 800-222-7820.

ICE PRODUCTION

No ice.

- Verify the  indicator appears in the control panel display.
- Verify the ice maker has been on for at least 24 hours.
- Verify the freezer temperature is near 0°F.
- Verify the ice container is properly installed.
- Verify the ice maker arm is in the down position.
- Verify water is being supplied to the unit.
- Verify the water filter has been replaced within the last 12 months and is installed properly.
- Verify the water filter has been removed if a reverse osmosis filtration system is being used.

- Verify the  indicator is not flashing. If it is flashing, touch MAX ICE and ICE MAKER on the control panel simultaneously.

Blue or green ice.

- Possible copper supply line corrosion. Contact a plumber to clean or replace.

Black flecks in the cubes.

- Stop use and contact Sub-Zero Factory Certified Service.

Bad taste.

- Defrost the freezer and clean with soap and water.
- Place coffee grounds or charcoal briquettes in the freezer to absorb odor.

Hollow cubes.

- Clean the condenser. Contact Sub-Zero Factory Certified Service if unresolved.

ODOR

- The unit should be cleaned before using for the first time. This will clear any odors that may have been trapped during shipping.
- Replace the air purification cartridge.
- Clean the unit and shelving thoroughly
- Uncovered food could create an odor, which may require cleaning.
- Remove and clean the drain pan located behind the kickplate, and reinstall.

SERVICE

- Maintain the quality built into your product by contacting Sub-Zero Factory Certified Service. For the name of the nearest Sub-Zero Factory Certified Service, check the Support & Service section of our website, subzero.com or call Sub-Zero Customer Care at 800-222-7820.
- When contacting service, you will need the model and serial number of your unit. Both numbers are listed on the product rating plate. Refer to page 3 for rating plate location.
- For warranty purposes, you will also need the date of installation and name of your authorized Sub-Zero dealer. This information should be recorded on page 2 of this guide.

Warning

This content is compiled from multiple sources and is provided for reference purposes only. It may not be complete or fully applicable to all situations. If you are unable to resolve your issue, please contact the product manufacturer or an authorized service provider for official support.

