

Product Features

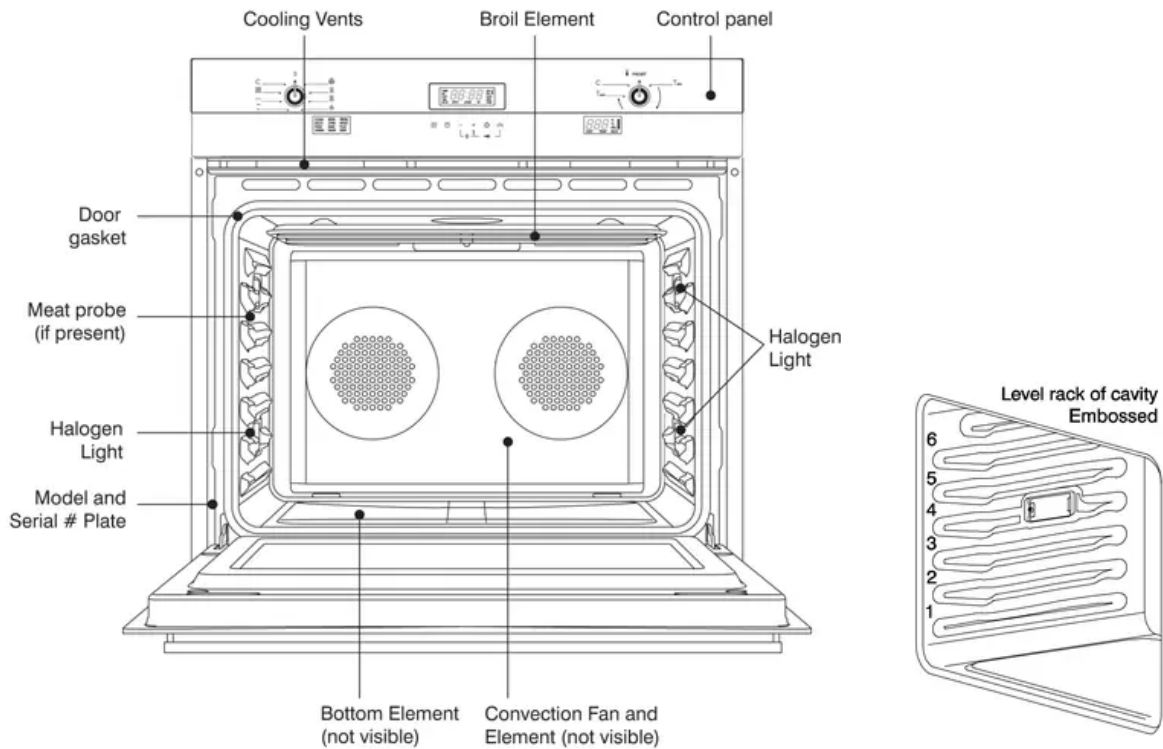

About Your Oven

Above you will find an illustration of an oven showing the components of the oven.

Cooling Fan

The oven has a cooling fan to cool the control panel. You may hear this fan continue to run after cooking and/or cleaning has been completed. The fan will run as long as the oven is hot and the oven's function selector is turned to any position other than "Off".

This is normal operation.

Rack Positions

The oven has rack guides at six levels as shown in the illustration.

Each level guide consists of paired supports formed in the sidewalls on each side of the oven cavity. The rack should be positioned within the paired supports.

Always be sure to position the oven racks, etc. before turning the oven on.

Make sure that the rack(s) are level once they are in position.

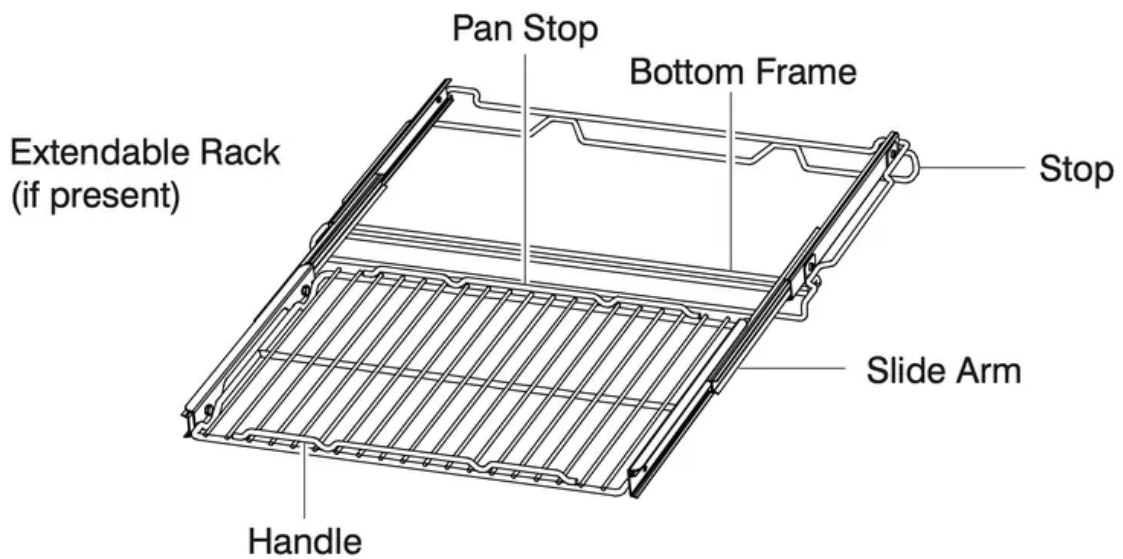
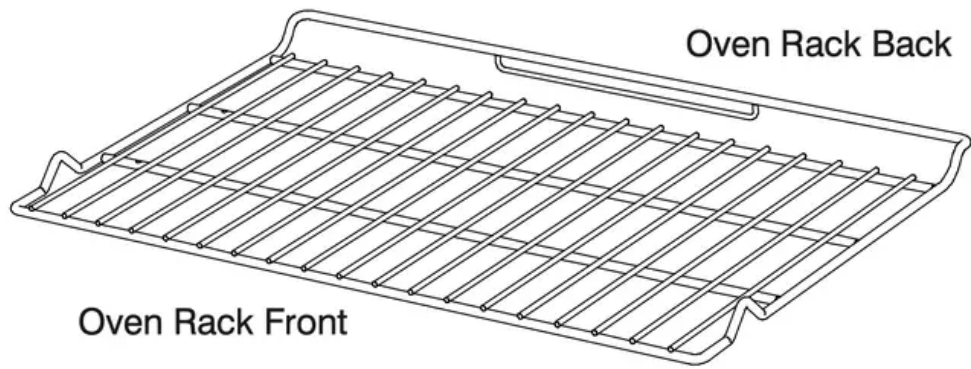

Baking Elements

The oven uses two elements for baking: one located at the top of the oven and the second located below the floor of the oven cavity to provide ease in cleaning the oven cavity.

Grilling Element

The grilling element of the oven is located at the top of the oven cavity.

Do not touch the heating element or let oven gloves touch the grilling element.

Never use a towel or bulky cloth for an oven glove; they could catch on fire.

Convection Element

The convection elements (not visible) and fans are located at the back of the oven cavity.

This element and fan combination performs the cooking when in the convection bake mode. When in any of the convection modes the fan is on, see Figure 1.

About Convection Ovens

In a conventional oven, the heat sources cycle on and off to maintain an average temperature in the oven cavity.

As the temperature gradually rises and falls, gentle air currents are produced within the oven. This natural convection tends to be inefficient because the currents are irregular and slow. In this convection system, the heat is “conveyed” by a fan that provides continuous circulation of the hot air.

This European Convection system provides state-of-the-art engineering and advanced design to create the finest convection oven. In standard convection ovens, a fan simply circulates the hot air around the food. The system is characterized by the combination of an additional heating element located around the convection fan and the venting panel that distributes heated air in three dimensions: along the sides, the top and the full depth of the oven cavity. This European Convection system aids in maintaining a more even oven temperature throughout the oven cavity.

The circulating air aids in speeding up the baking process and cooks the food more evenly. By controlling the movement of heated air, convection cooking produces evenly browned foods that are crispy on the outside yet moist inside. Convection cooking works best for breads and pastries as well as meats and poultry. Air-leavened foods like angel food cakes, soufflés and cream puffs rise higher than in a conventional oven. Meats stay juicy and tender while the outside is flavorful and crisp.

By using European Convection, foods can be cooked at a lower temperature and cooking times can be shorter.

When using this mode, the standard oven temperature should be lowered by 25°F (15°C). Foods requiring less cooking time should be checked slightly earlier than normal. For best results, foods should be cooked uncovered, in low-sided pans to take advantage of the forced air circulation. When using the Convection Roast mode, the standard oven temperature does not need to be reduced.

The Control Panels

The user interface has the following features: display, preheat light indicators, keys for commands, cooking mode and temperature selectors.

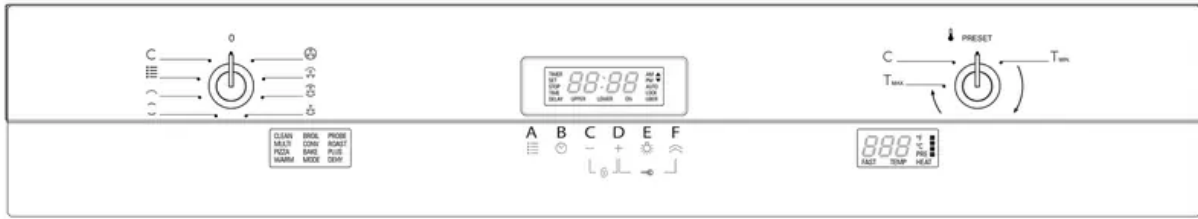

SINGLE OVEN



DOUBLE OVEN

Command Keys

B [TIME]: touch this key until “SET TIME” appears to set or change the time of day. Touch this key until “TIMER” appears to set, modify or clear the minute minder value.

Once a cooking function has been, touch this key until “TIME” appears in order to set, modify or cancel the cooking time. Touch this key until “STOP TIME” appears in order to set, modify or cancel the end of cooking time. Whenever one of the former modes has been enabled and its digits flash, touch or hold:

D [INC] key to increase the value.

C [DEC] key to decrease the value.

A (DOUBLE OVEN) - F (SINGLE OVEN) [FAST PREHEAT]

When a cooking function has been selected, touch this key to enable the fast preheat mode. The fast preheat is not available for all functions.

A [OPTION]

Touch this key to enable special functions, low temperature modes or to enter special menu.

E [LIGHT]: Touch it to switch the oven lights status.

F [UPPER/LOWER] (double oven): Touch this key to select the upper cavity if none is selected. If one of the two is already selected, touch it and switch to the other one.

Display

Central Red Display for time and miscellaneous functions: for time of day, minute minder, automatic cooking. AM/PM indication is also present.

Miscellaneous indications are also available to show which cavity is currently selected and whether any door has been locked, automatically for self-clean or manually by the user.

Red Display for Temperature indications: Degree unit (°C or °F) indication is present. It shows the temperature set-point for the current cooking mode, in the selected cavity.

Red Display with writings for Cooking Modes indication to indicate which function has been selected.

Knobs

Cooking mode selector (multifunction), with eight cooking modes + OFF position.

Cooking mode selector (thermal), with three cooking modes + OFF position.

Temperature selector with PRESET and CLEAN positions + continuous range between MIN and MAX values.

Oven Modes

The following illustrations give an overview of what happens in the oven with each mode setting. The arrows represent the location of the heat sources during specific modes. The lower element is concealed under the oven floor.

Thermal Cavity

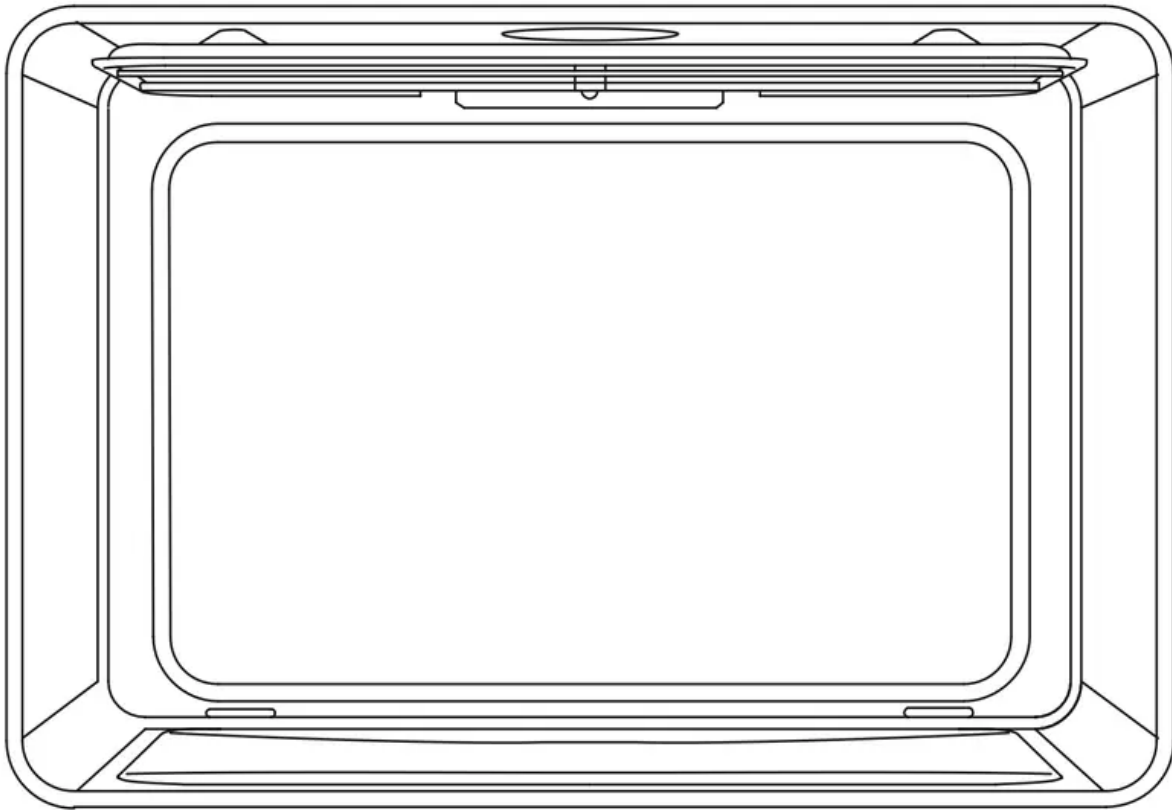

Double Convection Cavity

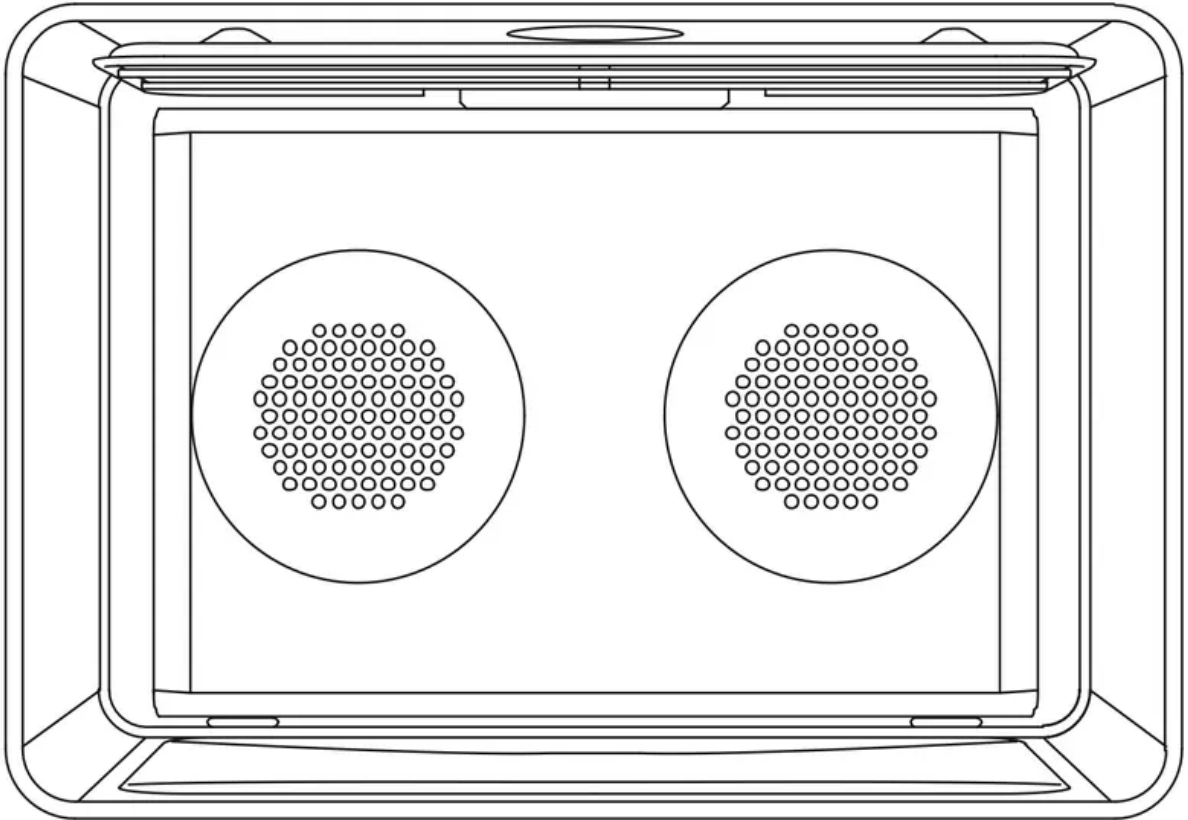

Convection Bake (CONV BAKE)

Set temperature: from 170 °F (75 °C) to 480 °F (250 °C) (preset position 325 °F (165 °C))

Convection Bake cooks with heat from a ring element behind the back wall of the oven. The heat is circulated throughout the oven by the convection fan.

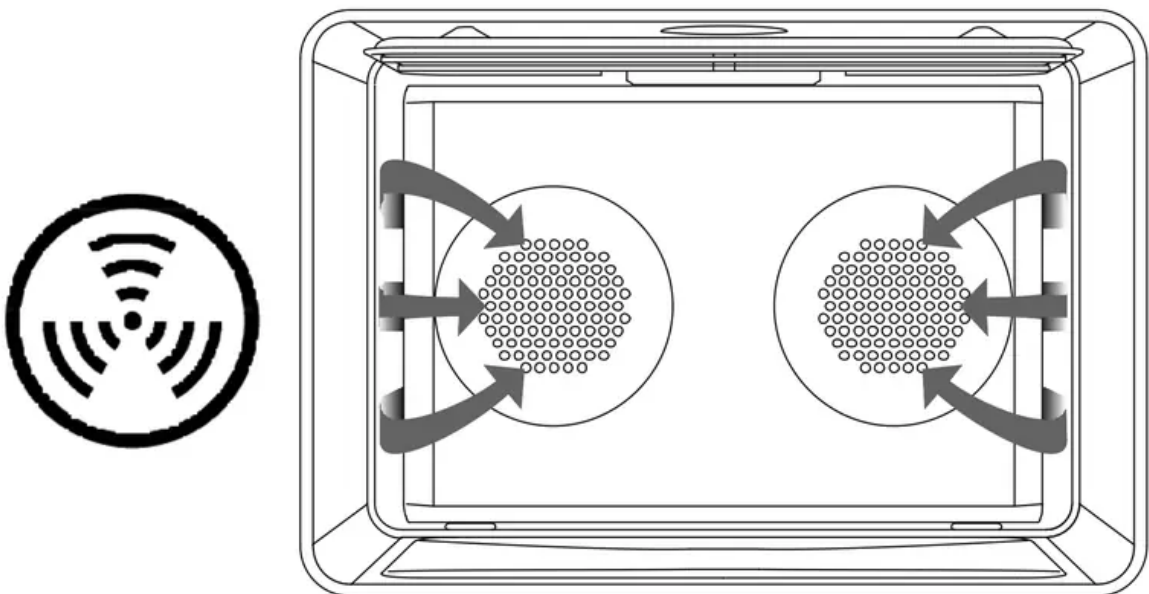

Bake (BAKE)



Set temperature: from 170 °F (75 °C) to 480 °F (250 °C) (preset position 350 °F (175 °C))
Is cooking with heated air. Both the upper and lower elements cycle to maintain the oven temperature.

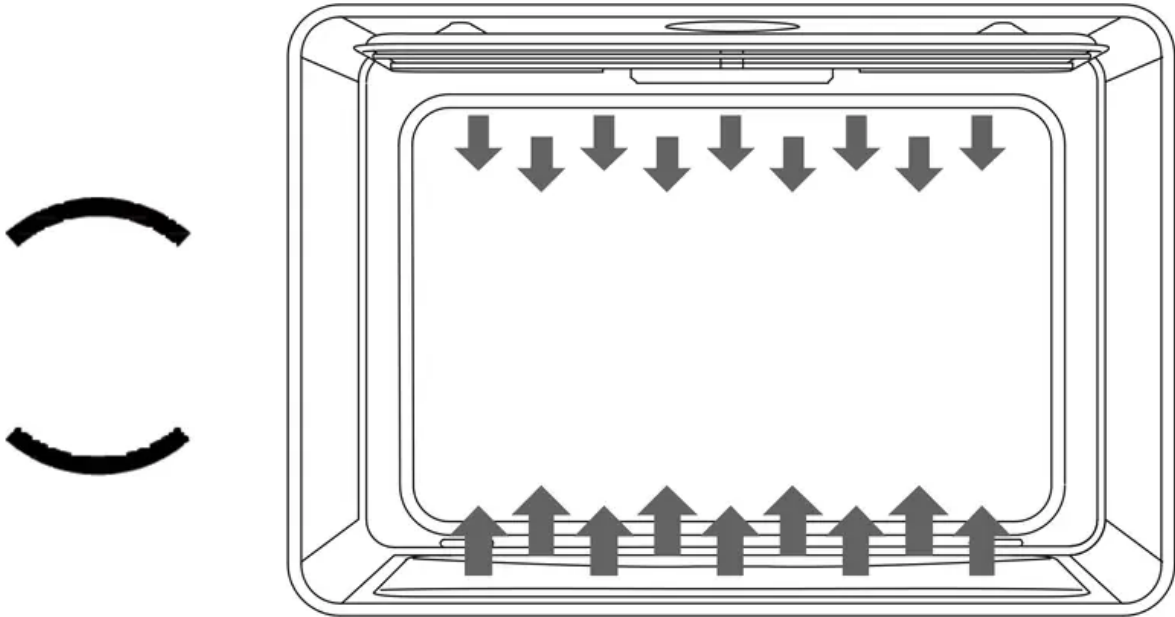

Dehydrate (CONV DEHY)

Set temperature: from 120 °F (50 °C) to 160 °F (70 °C) (preset position 140 °F (60 °C))
Dehydrating is similar to convection cooking but holds an optimum low temperature while circulating the heated air to remove moisture slowly for food preservation.

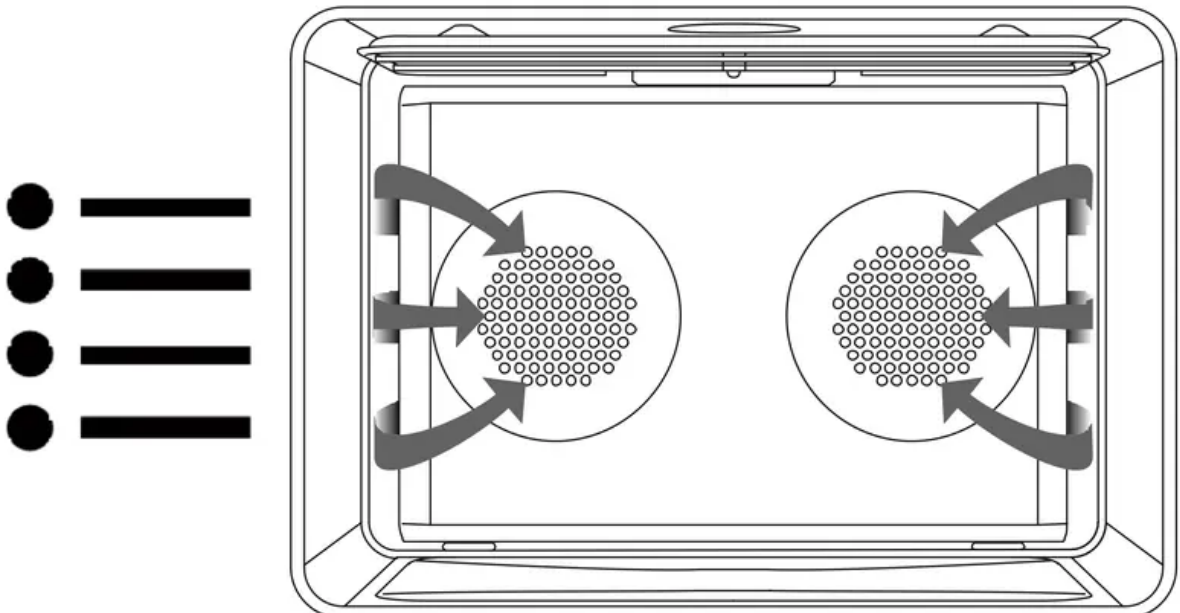

Convection Broil or Grill (CONV BROIL)

Set temperature: from 170 °F (75 °C) to 480 °F (250 °C) (preset position 450 °F (230 °C))
Convection Broil combines the intense heat from the upper element with the heat circulated by the convection fan.

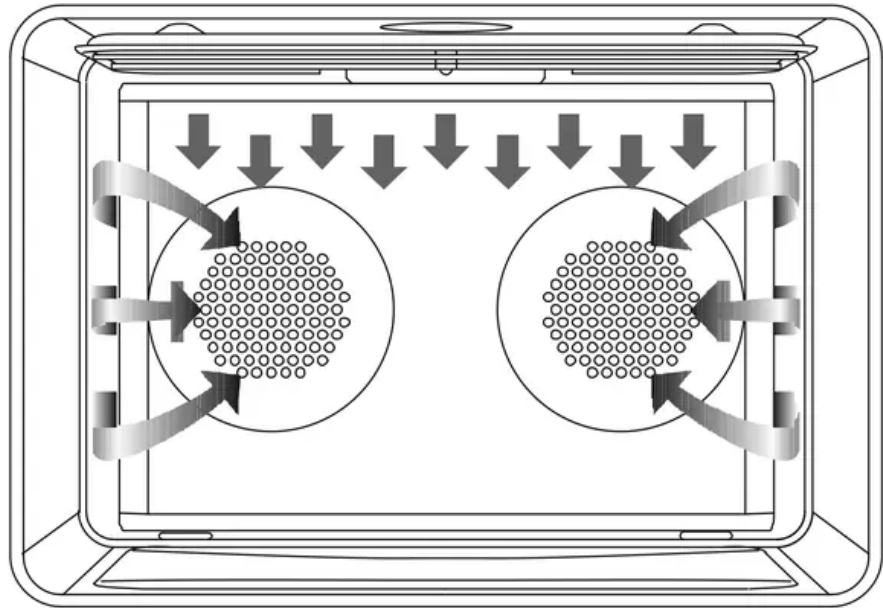

Broil or Grill (BROIL)

Set temperature: from L1 to L5 (preset position L3)

Broiling uses intense heat radiated from the upper element.

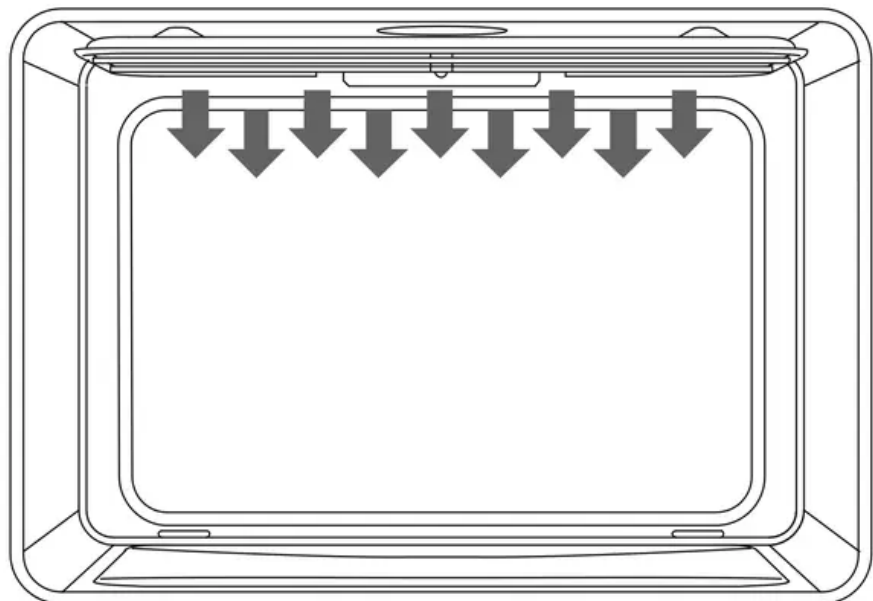

Pizza (PIZZA)

Set temperature: from 170 °F (75 °C) to 480 °F (250 °C) (preset position 450 °F (232 °C))

Is a special cooking mode with heated air. The lower elements cycle to cook Pizza.

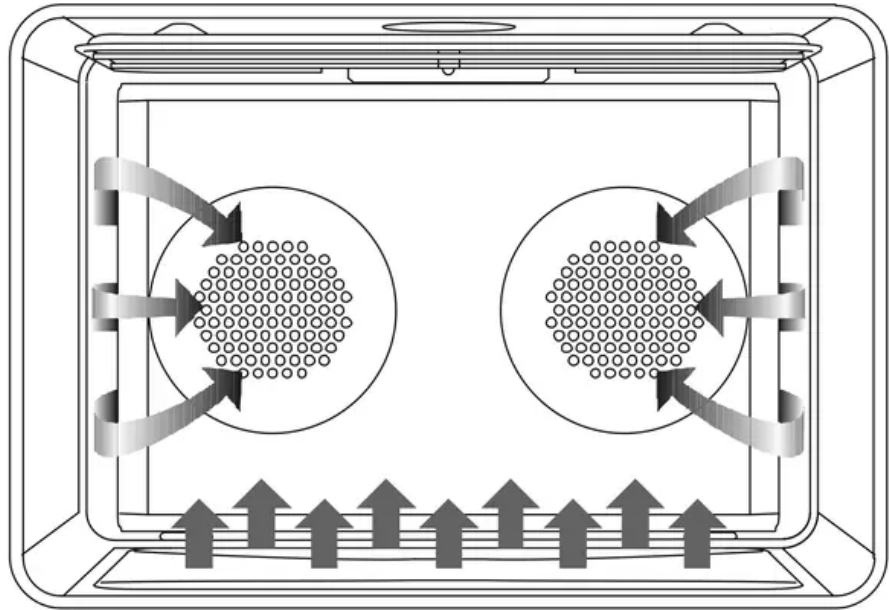

Convection Roast (CONV ROAST)

Set temperature: from 170 °F (75 °C) to 480 °F (250 °C) (preset position 325 °F (165 °C))

Convection Roast uses the upper and lower elements and convection fan.

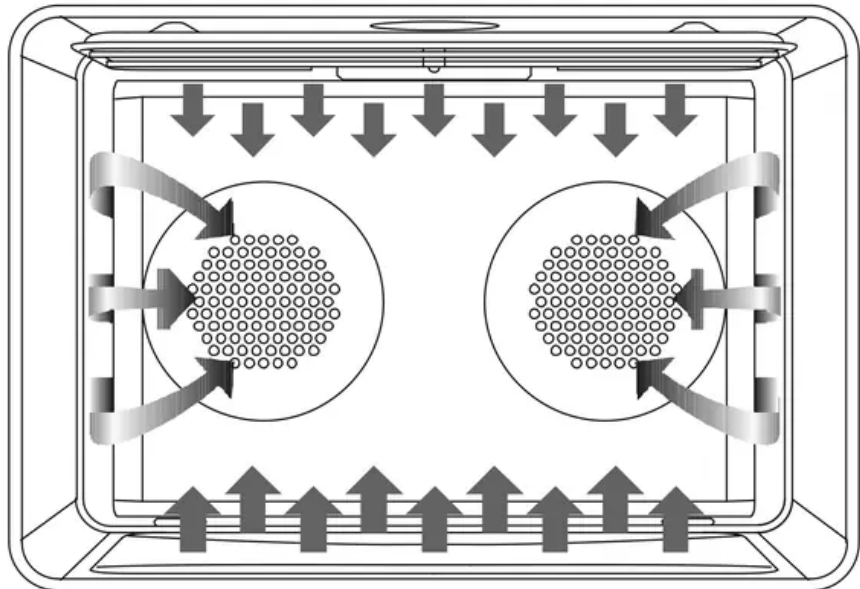

Proof (WARM)

Set temperature: from 80 °F (25 °C) to 120 °F (50 °C) (preset position 100 °F (35 °C))

Warming (WARM PLUS)

Set temperature: from 130 °F (55 °C) to 210 °F (100 °C) (preset position 170 °F (75 °C))

Proof and Warming use the lower elements to keep foods warm.

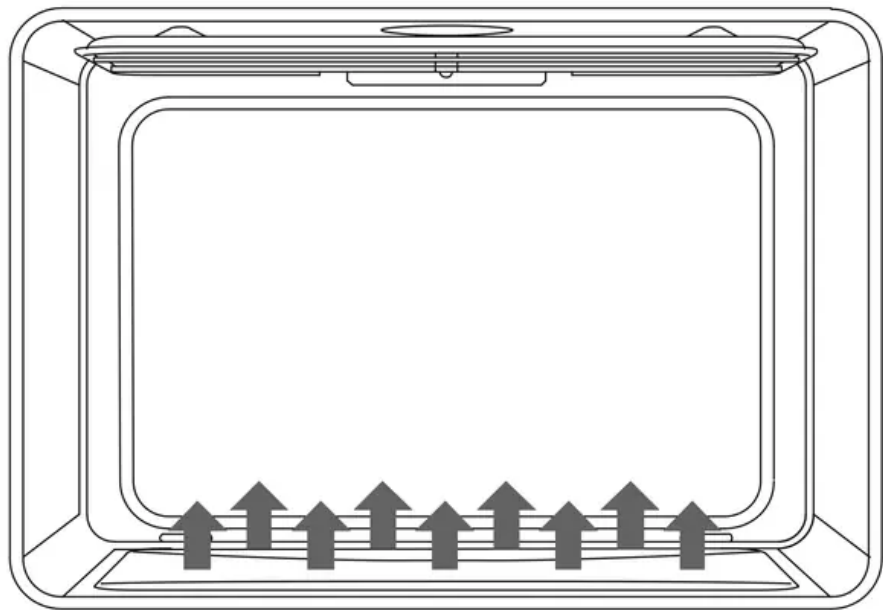
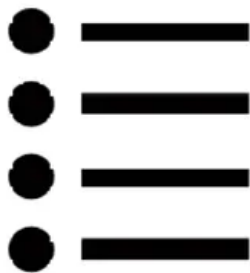

Defrost (CONV)

Not used any heating element only convection fan is used to defrost foods.

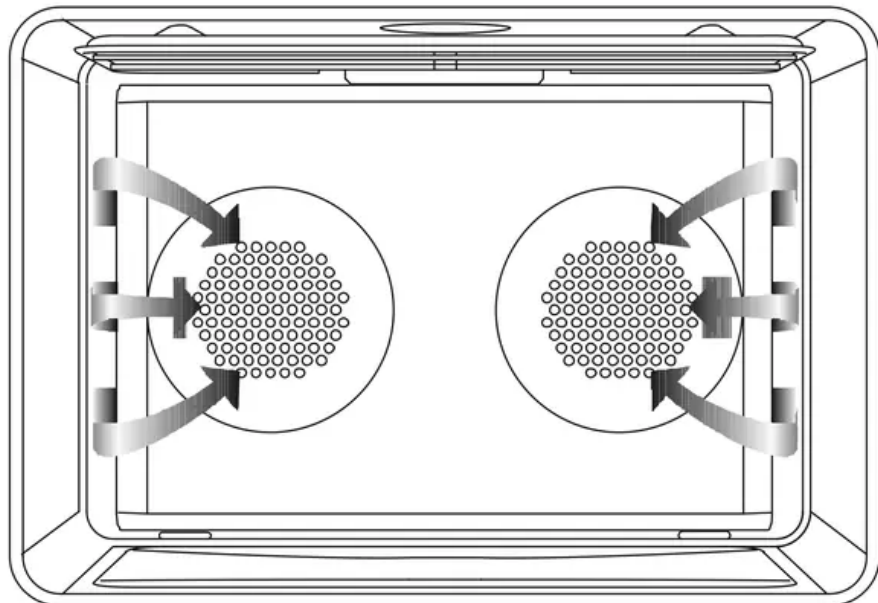
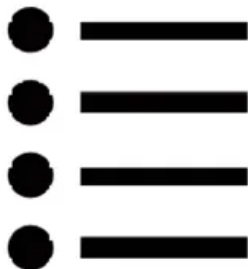

General Oven Information

Before using your oven for the first time remove all packing and foreign materials from the oven(s). Any material of this sort left inside may melt or burn when the appliance is used.

Flashing Symbols or Numbers

Signals an incomplete action that is in progress (locking the door, preheat, etc.) or an incomplete setting that calls for another input.

Beeps

Signals that more information must be entered or confirms the receipt of an entry. Beeps also signal the end of a function or an oven fault.

Locking the door

It's displayed steadily when the door is locked. The symbol flashes when the latch is moving in order to lock or unlock the door. Do not attempt to open the door at this time. Door can be opened when the symbol no longer appears. "AUTO LOCK" appears when the door has been locked automatically due to self-clean mode. "USER LOCK" is displayed when the door has been locked manually by the user, for example to prevent children from having free access to the oven cavity. Hold both the [INC] and [DEC] keys for 3 seconds. The latch will lock the door. Repeat the same operation to unlock.

Locking the keyboard

Hold both the keys indicated by "KEYBD. LOCK" legend for 3 seconds. Commands are now locked and "SENS LOCK" will be displayed every time you touch any keys. Repeat the same operation for 3 seconds to unlock the keyboard.

Power Failure

After the power returns to the oven, the clock displays the time 12.00AM .

Default Settings

The cooking modes automatically select a suitable temperature when the selector is in the preset position. These can be changed when a different one is needed. It's also possible to set a user option in order to save the last used temperature per every cooking mode.

F Failure Number Codes

These codes are displayed when the electronic control detects a problem in the oven or in the electronics.

Convection Fan

The convection fan operates during any convection mode. When the oven is operating in the convection mode, the fan will turn off automatically when the door is opened. The convection fan always runs during the preheat time.

Component Cooling Fan

Activates during any cooking or self-cleaning mode to cool inner components and outer door surfaces. This air is exhausted through the vent located above the oven door. It continues to run until components have cooled sufficiently. The cooling fan speed is high in self-clean and whenever the internal components temperature becomes high.

Preheat and Boost

Whenever a cooking mode is set and the oven is heating, the "PREHEAT" writing appears in the temperature display: the vertical bar indicates, in four steps, when the oven reaches the 25%, 50%, 75%, 100% of the set-point temperature. As soon as the 100% is reached, the control sounds an "end of preheat" tone and the "PREHEAT" writing disappears.

When it's necessary to heat up the oven rapidly, a Boost mode is available: it uses the heating elements and the convection fan in a special way, in order to reduce the heating time as long as possible.

After having set one of the cooking functions for which the fast preheat is available, touch the [BOOST] key, the "FAST" writing is shown in addition to the "PREHEAT" one.

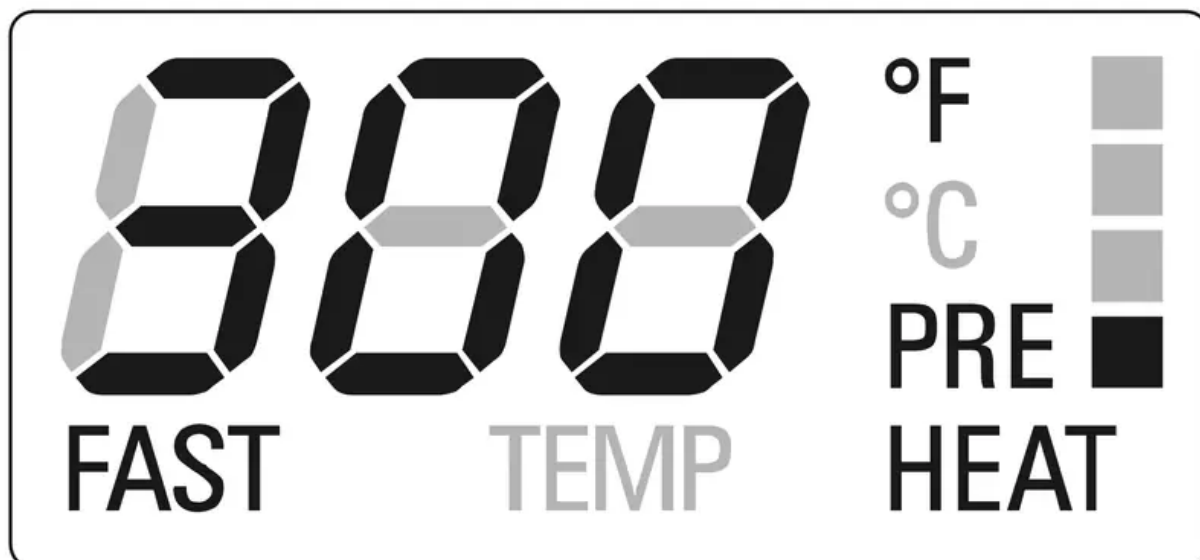

As soon as the set-point temperature is reached, the control sounds an "end of preheat" tone and both "FAST" and "PREHEAT" writings disappear. The oven switches automatically to the desired cooking mode that was previously set: put the food inside now.

General Oven Tips

Preheating the Oven

- Preheat the oven when using the Bake, Convection Bake and Convection Roast modes.
- Use BOOST mode when a short time is necessary to preheat the oven.
- Selecting a higher temperature does not shorten the preheat time.
- Preheating is necessary for good results when baking cakes, cookies, pastry and breads.
- Preheating will help to sear roasts and seal in meat juices.
- Place oven racks in their proper position before preheating.
- During preheating, the selected cooking temperature is always displayed.
- A beep will confirm that the oven is preheated and the "PREHEAT" writing will turn off.

Operational Suggestions

- Use the cooking charts as a guide.
- Do not set pans on the open oven door.

- Use the interior oven lights to view the food through the oven door window rather than opening the door frequently.

Utensils

- Glass baking dishes absorb heat. Reduce oven temperature 25 °F (15 °C) when baking in glass.
- Use pans that give the desired browning. The type of finish on the pan will help determine the amount of browning that will occur.
- Shiny, smooth metal or light non-stick / anodized pans reflect heat, resulting in lighter, more delicate browning. Cakes and cookies require this type of utensil.
- Dark, rough or dull pans will absorb heat resulting in a browner, crisper crust. Use this type for pies.
- For brown, crisp crusts, use dark non-stick / anodized or dark, dull metal utensils or glass bake ware. Insulated baking pans may increase the length of cooking time.
- Do not cook with the empty broiler pan in the oven, as this could change cooking performance. Store the broil pan outside of the oven.

Oven Condensation and Temperature

- It is normal for a certain amount of moisture to evaporate from the food during any cooking process. The amount depends on the moisture content of the food. The moisture may condense on any surface cooler than the inside of the oven, such as the control panel.
- Your new oven has an electronic temperature sensor that allows maintaining the selected temperature accurately. Your previous oven may have had a mechanical thermostat that drifted gradually over time to a higher temperature. It is normal that you may need to adjust your favorite recipes when cooking in a new oven.

High Altitude Baking

- When cooking at high altitude, recipes and cooking time will vary from the standard.

Oven Racks

- The oven has rack guides at six levels as shown in the illustration on Page 6.
- Rack positions are numbered from the bottom rack guide (#1) to the top (#6).
- Check cooking charts for best rack positions to use when cooking.
- Each level guide consists of paired supports formed in the walls on each side of the oven cavity.
- Always be sure to position the oven racks before turning on the oven. Make sure that the racks are level once they are in position.

Please refer to illustration on Page 6 if there is any question as to which side is the front of the rack.

- The racks are designed to stop when pulled forward to their limit.

CAUTION:

Never use aluminum foil to cover the oven racks or to line the oven. It can cause damage to the oven liner if heat is trapped under the foil.

Make sure you do not force it to avoid damage to the enamel.

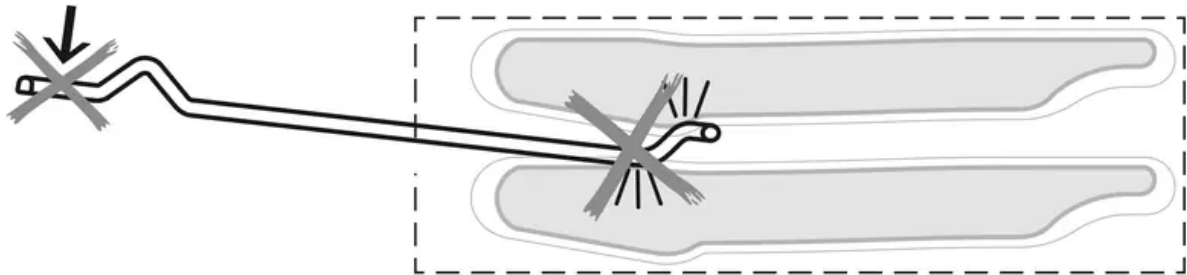

To remove oven rack from the oven:

1. Pull rack forward

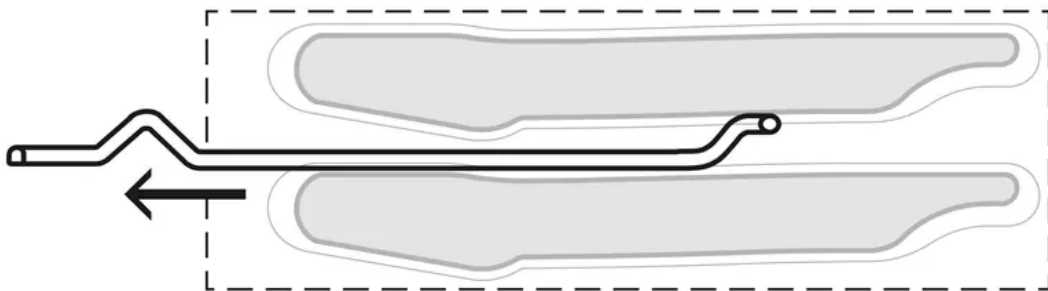

2. Lift rack up at front and then remove it

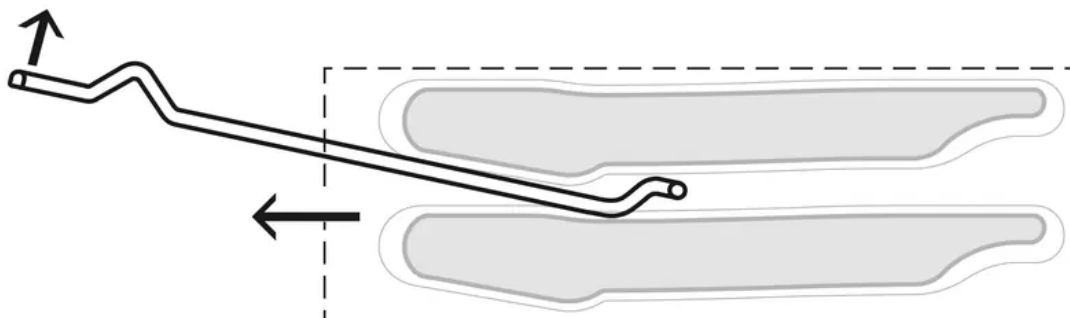

To replace an oven rack:

1. Place rear of rack between rack level guides

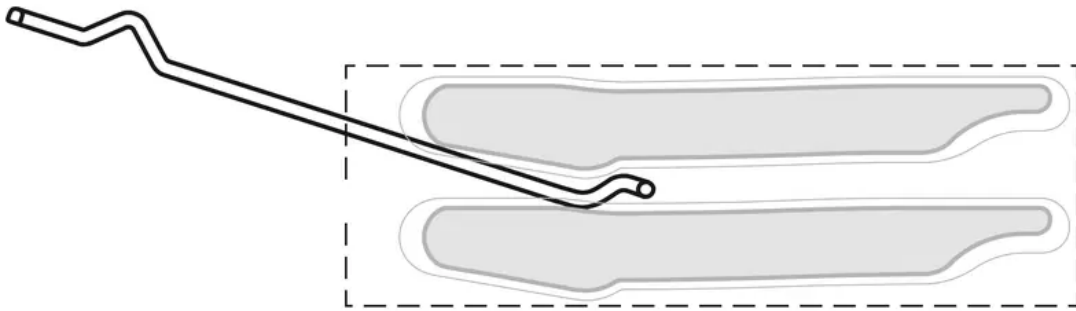

2. While lifting front of rack, slide rack in all the way while lowering the front

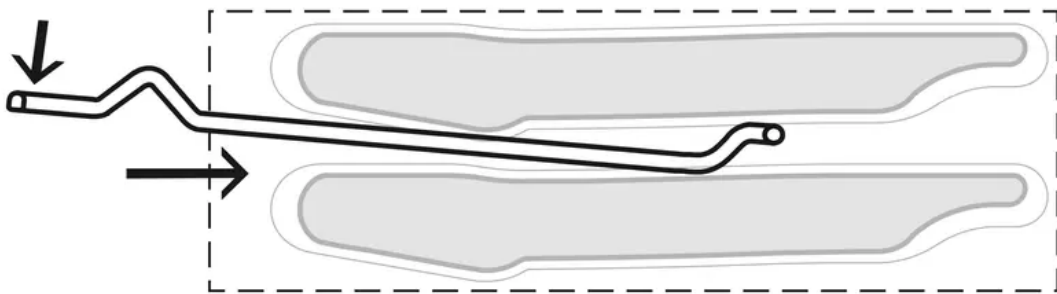

Oven Extendable Racks

- The extendable rack allows for easier access to cooking foods. It extends beyond the standard flat rack bringing the food closer to the user.

CAUTION: When the rack is outside of the oven, slide arms do not lock. They could unexpectedly extend if the rack is carried incorrectly. Extending slide arms could cause injury. Rack should only be held or carried by grasping the sides.

NOTE: Always remove the extendable rack before self-cleaning the oven.

To avoid burns, pull rack all the way out and lift pan above handle when transferring food to and from oven.

To remove extendable rack from the oven:

1. Lift of rack slightly and push it until the stop release

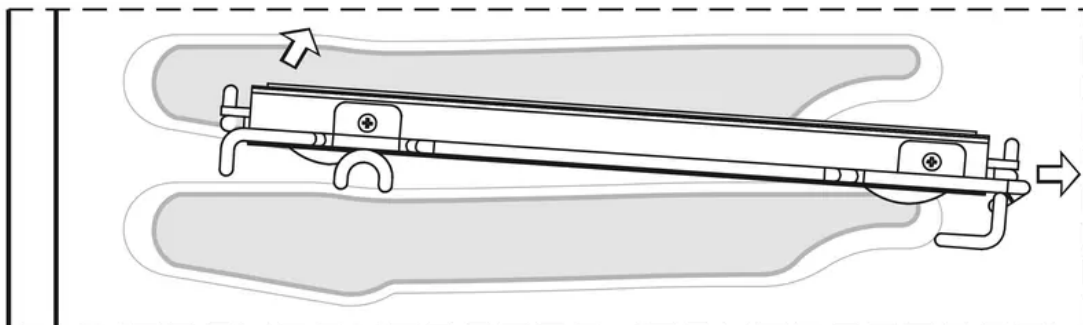

2. Raise back of rack until frame and stop clear rack guide

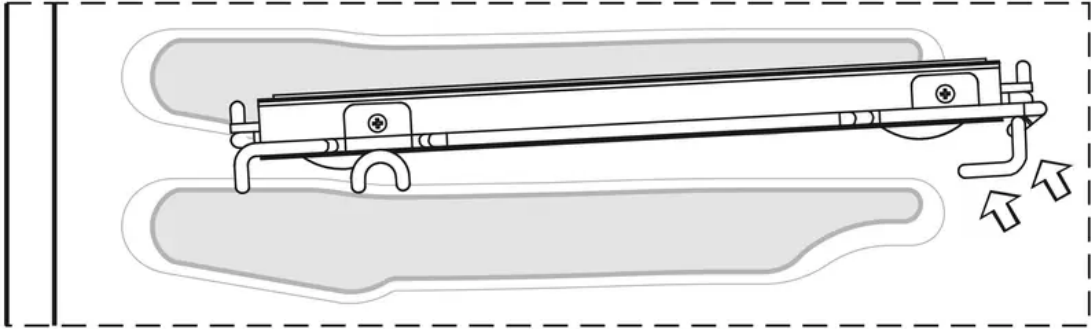

3. Pull rack down and out

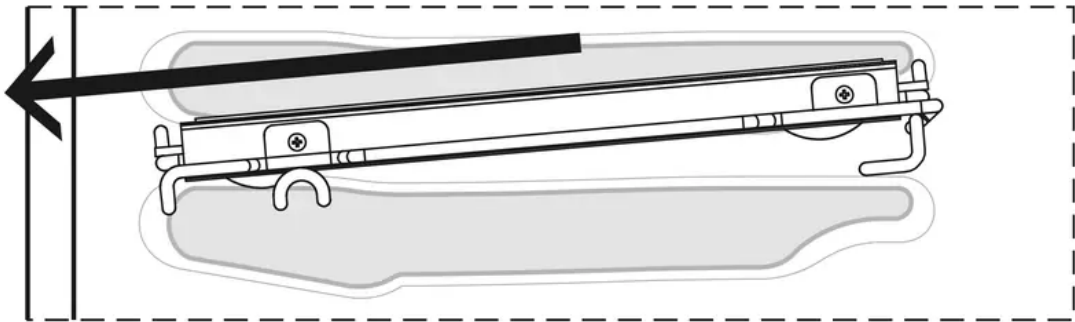

To replace an extendable rack:

1. Grasp rack firmly on both sides. Place rack (including frame) above desired rack guide

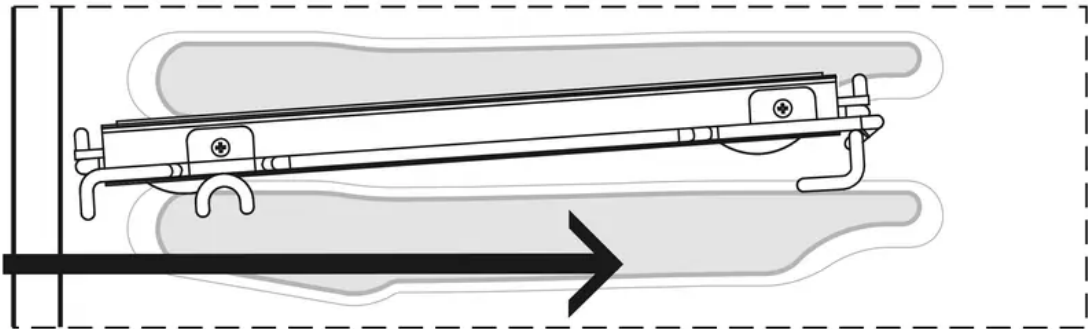

2. Push all the way in until the back of the rack drops into place

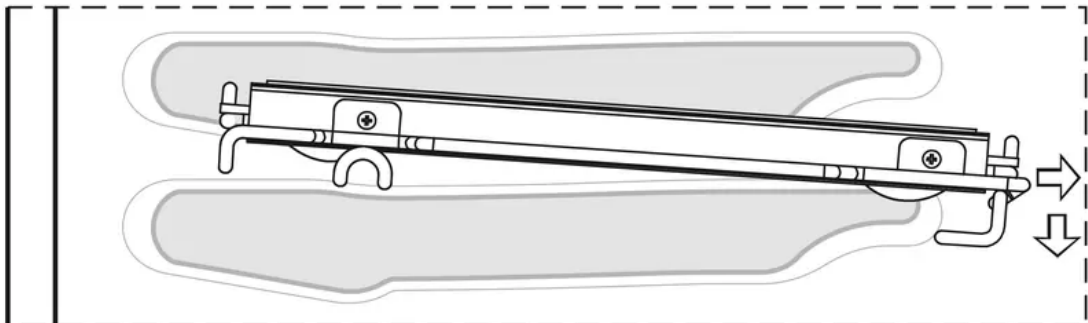

3. Pull both sections forward until stops activates. Rack should be straight and flat, not crooked

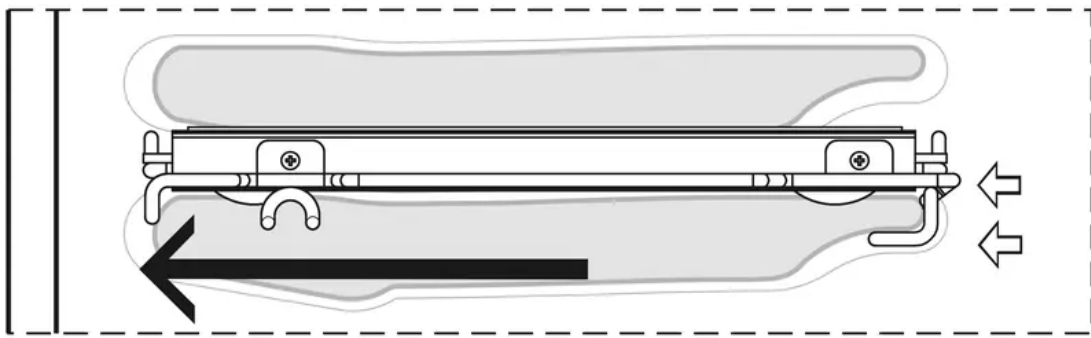

Setting the Clock and Timer

The time of day is displayed in hours and minutes.

Always set the clock immediately after installation or after a power failure. Once power returns to the oven, the clock displays the time 12:00AM .

The clock time will appear during all oven operations except when there is the timer or any timed cooking operations running.

The oven is preset to a 12-hour clock and indicates AM andPM .

To Set the Time of Day

1. Touch [TIME] until the display will show the "SET TIME" writing.
2. Touch [INC] or [DEC] to set the desired time, the hours will begin flashing: continue until the correct hour value and AM or PM indication is selected.
3. Touch [TIME] again to confirm the hour and minutes will start flashing.
4. Touch [INC] or [DEC] to set the desired minutes value or hold the key to change by 10 minute steps.
5. Touch [TIME] again or wait for 5 seconds in order to confirm the time.

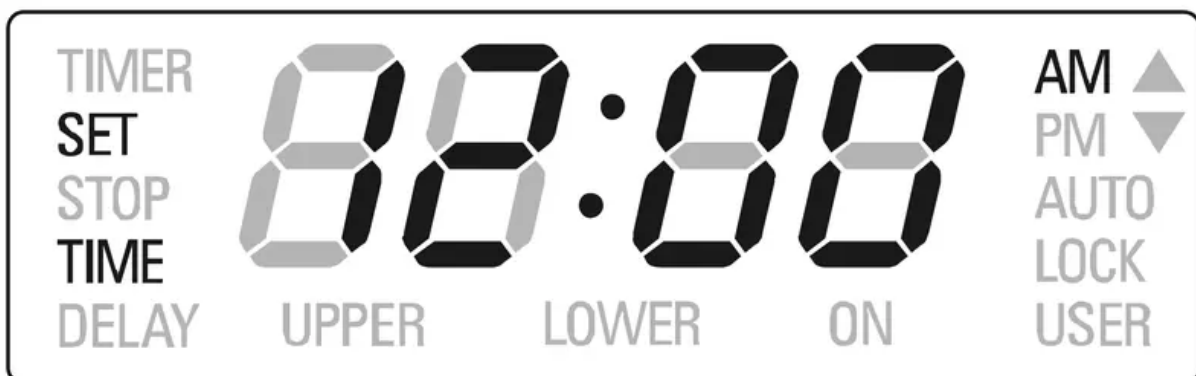

NOTE: The Time of Day can never be set if any time function is already set: first delete all the active time functions.

To Set the Timer



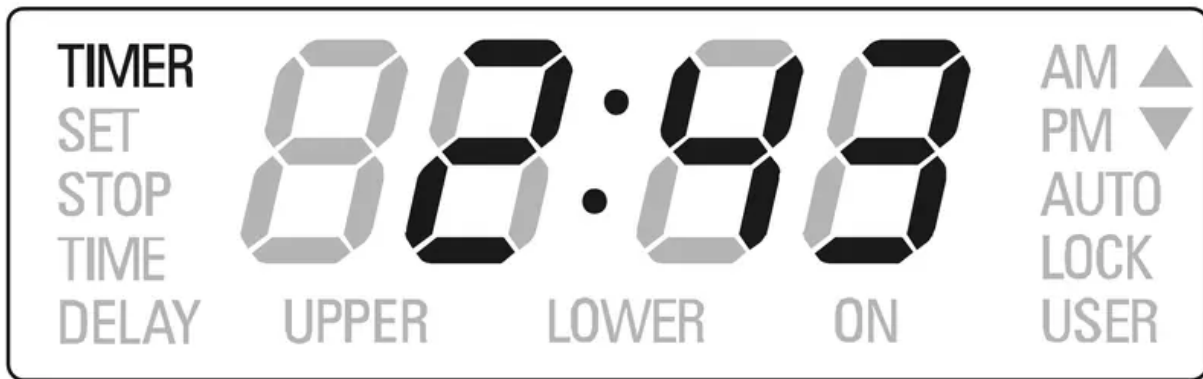







1. Touch [TIME] until the display will show the "TIMER" writing.
2. Touch [INC] or [DEC] to set the desired timer value, the hours will begin flashing: continue until the desired value is set.
3. Touch [TIME] again to confirm the hour and minutes will start flashing.
4. Touch [INC] or [DEC] to set the desired minutes value or hold the key to change by 10 minute steps.
5. Touch [TIME] again or wait for 5 seconds in order to confirm the time.
6. "TIMER" will be steadily displayed.
7. When the time ends, reminder beeps will sound for 15 minutes or until the [TIME] key is pressed.
8. Timer format is usually HR:MIN, switching into MIN:SEC during the last minute.
9. The displayed value is always rounded to the lower minute.



Selecting the Oven Mode

Setting Cooking Mode and Temperature

- The following modes can be selected by moving the cooking mode knob to the desired position. To select Clean, the temperature knob must be moved into the appropriate Clean position too.

- 0 **OFF**
-  **CONVECTION BAKE (CONV BAKE)**
-  **CONVECTION BROIL (CONV GRILL)**
-  **CONVECTION ROAST (CONV ROAST)**
-  **PIZZA (PIZZA)**
-  **BAKE (BAKE)**
-  **BROIL (GRILL)**
-  **DEHYDRATE (CONV DEHY)**
-  **PROOF (WARM)**
-  **DEFROST (CONV)**
-  **WARMING (WARM PLUS)**
- C **CLEAN**

- Select the desired temperature moving the selector or leave it in the PRESET position if the proposed value is fine. The temperature can be changed by 5°F or 5°C steps.
- As soon as one of the knobs is moved, the control switches automatically to display the value in the correspondent cavity. The corresponding writing “UPPER” or “LOWER” appears.
- Cavity will begin to heat, the “ON” writing is displayed when the selected oven is active, oven lights will turn on.
- “PREHEAT” writing will turn on. Once the oven has preheated, it will beep and switch the writing off.
- To change the temperature while cooking, simply turn the temperature knob until the display shows the desired value.
- Touch [UPPER/LOWER] to select the desired cavity and check the related temperature or time values, even if there's no need to change those.
- Move the cooking mode selector to OFF if you intend to stop cooking.

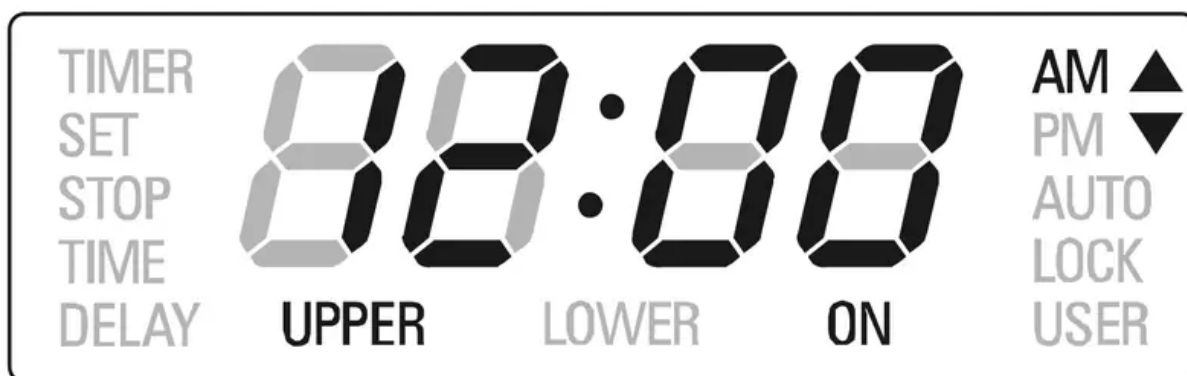

The triangles in the upper right corner of the display are active when a cavity is running, even if it is not selected on the display.

Using [MENU] key to select low temperature functions

- Moving the cooking mode selector to Low Temp position one of the following functions is displayed:

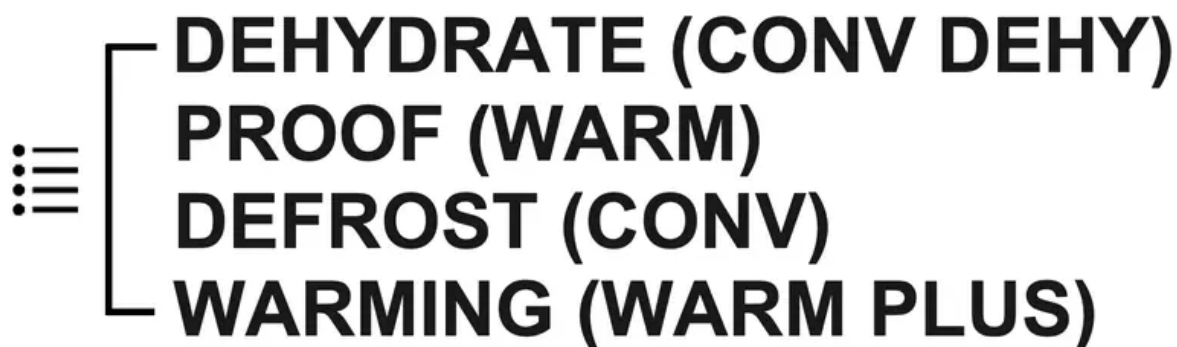

- Touch [MENU] key to toggle between these four modes.
- The last used is kept in memory for the next selection.

Using Oven Lights

- A single light key activates the lights in either oven.
- If [LIGHT] key is touched when both ovens are off, lights in both the upper and lower oven will turn on. Touch [LIGHT] key again, and both oven lights will turn off.
- Oven lights turn on and off automatically when the door is opened and closed.
- When an oven is in use, oven lights turn on automatically when a mode is started. Oven lights will turn off automatically when the oven mode is cancelled.
- The lights do not operate in the Self-Clean mode.

To manually control the interior oven lights in either the upper or lower oven if one or both ovens are in use:

1. Touch [UPPER/LOWER] and the display will indicate which oven is selected.
2. Touch [UPPER/LOWER] to highlight the other oven.

3. Touch [LIGHT] to turn lights on or off in the desired cavity.

Time Oven Mode Operation

- In double oven models, both ovens can be set independently to operate a timed mode.
- Be sure that the time-of-day clock is displaying the correct time.
- The timed mode turns off the oven at the end of the cook time.

To Set a Timed Mode

1. Select the oven by means of [UPPER/LOWER] key, if necessary.
2. Select the cooking mode and the temperature by means of the knobs. The “ON” writing will appear in the display.
3. Touch [TIME] key until the “TIME” writings will appear in the display.
4. Touch [INC] or [DEC], the hour digits will begin flashing. Continue to set the desired cooking time. Keep in mind that the time required for the oven to reach the temperature must be included in the set cooking time.
5. Touch [TIME] again, the hours will be confirmed and the minute digits will begin flashing.
6. Touch [INC] or [DEC] to change the minutes. Hold the key to change by 10 minutes steps. Continue to set the desired cooking time.
7. Touch [TIME] once again or wait for a few seconds to confirm the cooking time value.

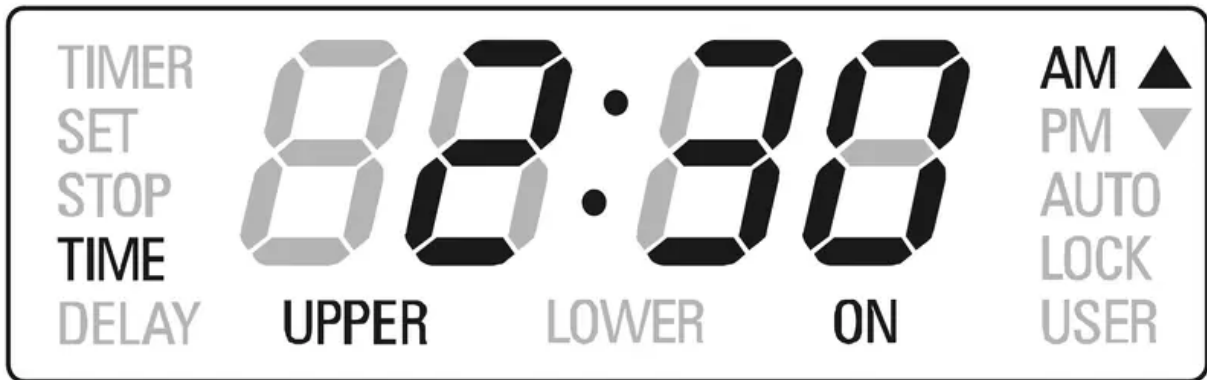

To Delay the Start of a Timed Mode

Follow steps 1 through 6 or 7 above.

- Touch [TIME] key until “STOP TIME” will appear in the display.

- The control automatically calculates and display the initial value, adding the cooking time already set to the time of day.

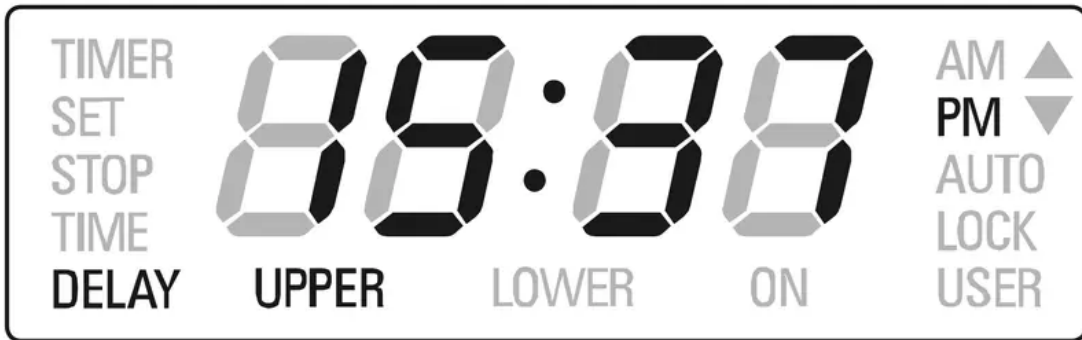

- Touch [INC] or [DEC], the hour digits will begin flashing. Continue to set the desired stop time.
- Touch [TIME] again, the hours will be confirmed and the minute digits will begin flashing.
- Touch [INC] or [DEC] to change the minutes.
Hold the key to change by 10 minutes steps. Continue to set the desired stop time.
- Touch [TIME] once again or wait for a few seconds to confirm the stop time value.
- The clock automatically calculates the time of day at which the mode starts and stops.
The “DELAY” writing is displayed until the starting time is reached.

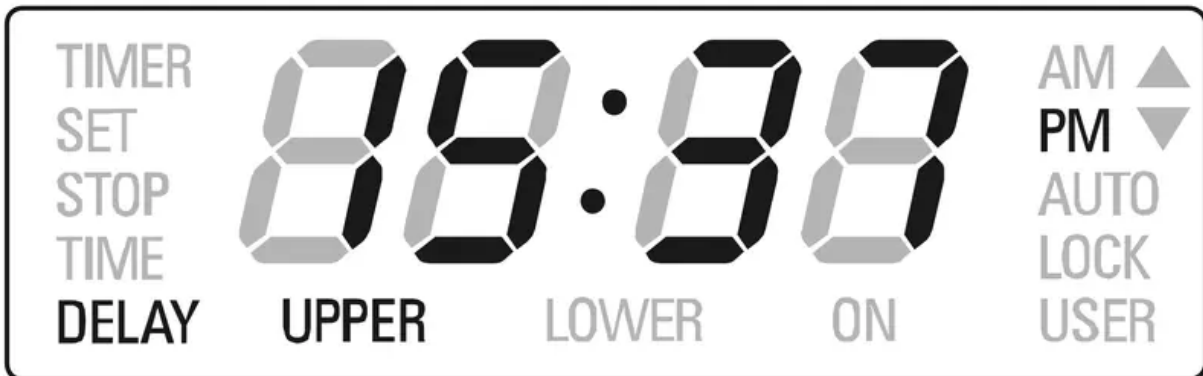

When a Timed Mode is running

- As soon as the oven actually starts cooking, the display shows the cooking time and counts down by one minute steps. The oven will cook for the programmed time.
- When the time expires, the oven automatically turns off, the writings “ON” and “TIME” start flashing and an “end of activity” beep sequence sounds. Reminder beeps will sound for up to fifteen minutes until any key is touched in order to recall the user attention.

How to check a time value

- Whenever it's necessary to check a time value that is not displayed, touch the [TIME] key until the proper writing is displayed to view the desired value for 5 seconds.
- **Example:** if the timer value is displayed and you want to check the cooking time, touch the [TIME] key until “TIME” is displayed to view the cooking time for 5 seconds.

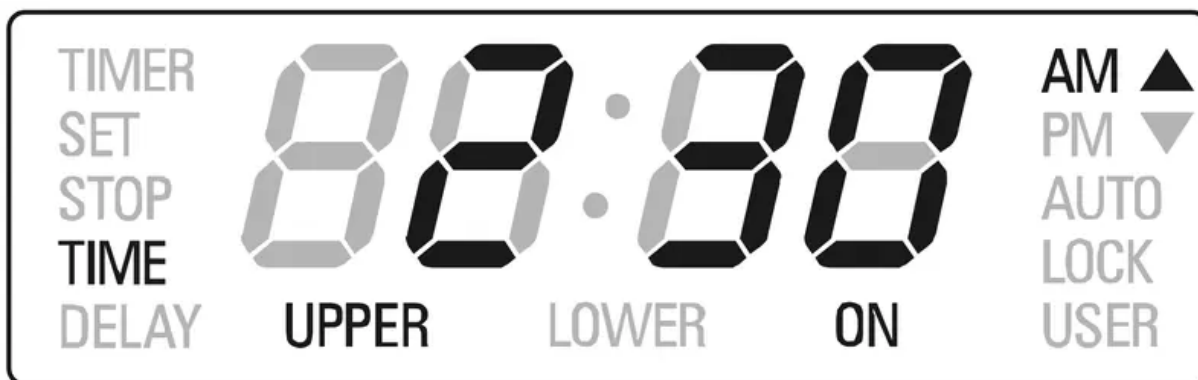

Meat Probe

NOTE: Only use the temperature probe recommended for this oven.

This oven is optionally provided with the meat probe feature to sense the temperature inside meat and stop cooking as soon as the set value is reached. In a double oven it's available only in the upper cavity.

The following modes can be selected to work with the meat probe:



Other modes are not allowed to start if the probe is inserted.

Once the probe has been inserted in its receptacle and detected by the control, turn the cooking mode knob into a valid position, the PROBE writing appears on the cooking mode display with the selected function.

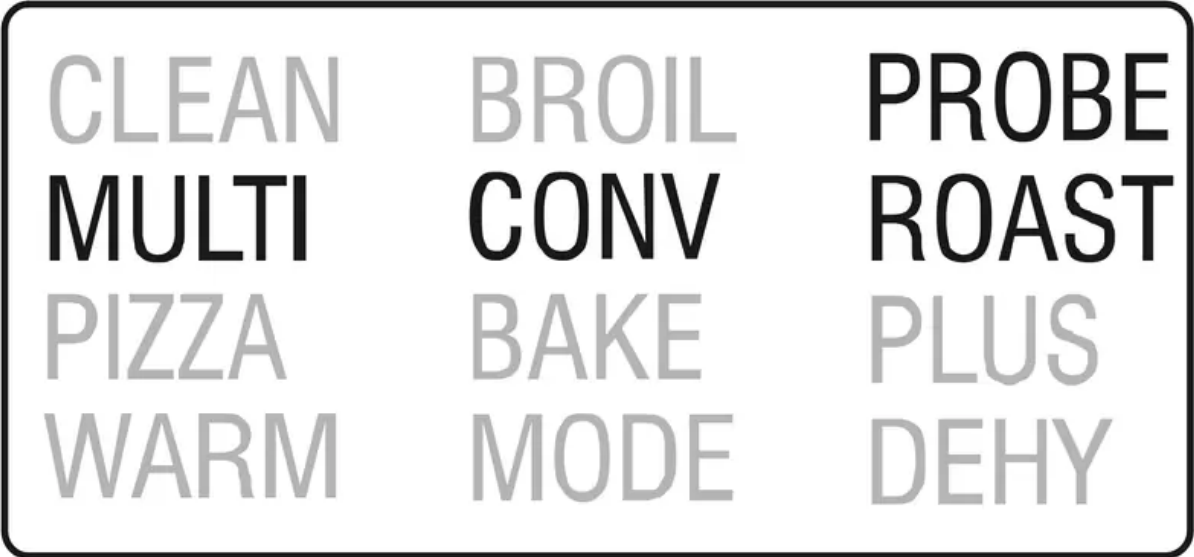

The meat probe standard temperature 170°F (75°C) flashes on the clock module for 5 seconds.

Using the [INC]/[DEC] keys, it's possible to change the probe set. The standard probe temperature set-point is 170°F (75°C). The allowed range is between 130°F (55°C) and 210°F (100°C). The maximum cavity temperature during cooking with meat probe is 475°F (290°C). The resolution must be 5°F or 2.5 °C both for set and actual temperature. After 5 seconds the value on the display is accepted and the control starts cooking. The actual probe temperature is now displayed.

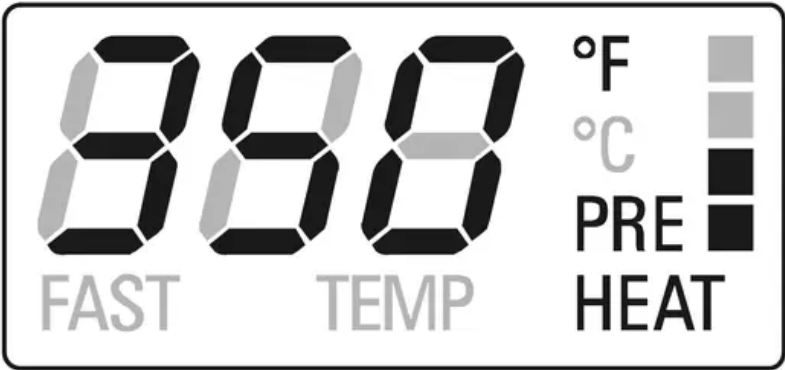
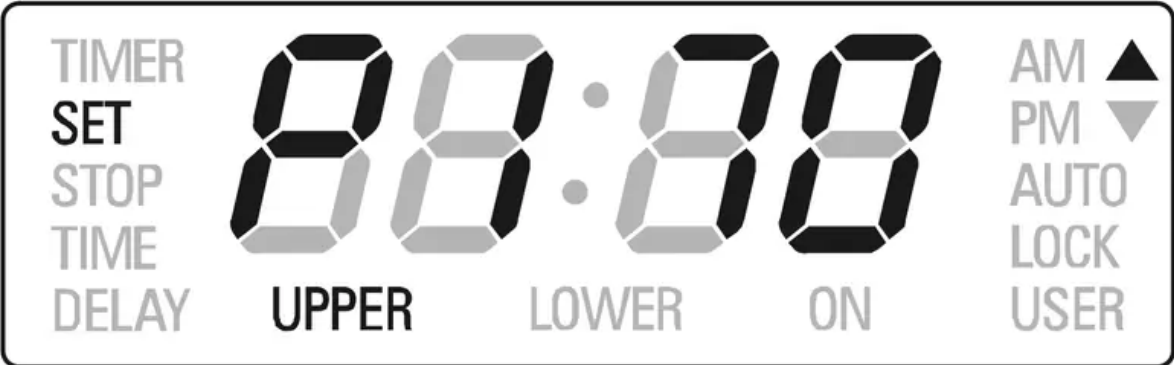

Touch [INC] or [DEC] once to check the probe set temperature. When it's flashing touch it further or hold to modify the value. As soon as the set probe temperature is reached, the control sounds an end of cooking tone and stops the oven.

Always turn the cooking mode in the OFF position before re-using the oven.

The PROBE writing flashes when the mode is not valid for cooking with probe. If the probe is removed during cooking, or in case of a short or open circuit, a fault message must be displayed.

Automatic time functions are disabled when using the meat probe, only the timer can work.



Bake Tips and Techniques

Baking is cooking with heated air. Both upper and lower elements in the oven are used to heat the air but no fan is used to circulate the heat.

Follow the recipe or convenience food directions for baking temperature, time and rack position. Baking time will vary with the temperature of ingredients and the size, shape and finish of the baking utensil.

General Guidelines

- For best results, bake food on a single rack with at least 1" - 1 ½" (2,5 – 3 cm) space between utensils and oven walls.
- Use one rack when selecting the bake mode.
- Check for doneness at the minimum time.
- Use metal bake ware (with or without a non stick finish), heatproof glass, glass-ceramic, pottery or other utensils suitable for the oven.
- When using heatproof glass, reduce temperature by 25 °F (15 °C) from recommended temperature.
- Use baking sheets with or without sides or jelly roll pans.
- Dark metal pans or non-stick coatings will cook faster with more browning. Insulated bake ware will slightly lengthen the cooking time for most foods.
- Do not use aluminum foil or disposable aluminum trays to line any part of the oven. Foil is an excellent heat insulator and heat will be trapped beneath it. This will alter the cooking performance and can damage the finish of the oven.
- Avoid using the opened door as a shelf to place pans.
- Tips for Solving Baking Problems are found on Page 31.

Bake Chart

FOOD ITEM	RACK POSITION	TEMP. °F (°C) (PREHEATED OVEN)	TIME (MIN)
Cake			
Cupcakes	2	350 (175)	19-22
Bundt Cake	1	350 (175)	40-45
Angel Food	1	350 (175)	35-39
Pie			
2 crust, fresh, 9"	2	375-400 (190-205)	45-50
2 crust, frozen fruit, 9"	2	375 (190)	68-78
Cookies			
Sugar	2	350-375 (175-190)	8-10
Chocolate Chip	2	350-375 (175-190)	8-13
Brownies	2	350 (175)	29-36
Breads			
Yeast bread loaf, 9x5	2	375 (190)	18-22
Yeast rolls	2	375-400 (190-205)	12-15
Biscuits	2	375-400 (190-205)	7-9
Muffins	2	425 (220)	15-19
Pizza			
Frozen	2	400-450 (205-235)	23-26
Fresh	2	475 (246)	15-18



Convection Bake Tips and Techniques

Reduce recipe baking temperatures by 25 °F (15 °C).

- For best results, foods should be cooked uncovered, in low-sided pans to take advantage of the forced air circulation. Use shiny aluminum pans for best results unless otherwise specified.
- Heatproof glass or ceramic can be used. Reduce temperature by another 25 °F (15 °C) when using heatproof glass dishes for a total reduction of 50 °F (30 °C).
- Dark metal pans may be used. Note that food may brown faster when using dark metal bake ware.
- The number of racks used is determined by the height of the food to be cooked.
- Baked items, for the most part, cook extremely well in convection. Don't try to convert recipes such as custards, quiches, pumpkin pie, or cheesecakes, which do not benefit from the convection-heating process. Use the regular Bake mode for these foods.
- Multiple rack cooking for oven meals is done on rack positions 1, 2, 3 and 4. All four racks can be used for cookies, biscuits and appetizers.
 - 2 Rack baking: Use positions 1 and 3.
 - 3 rack baking: Use positions 2, 3 and 4 or 1, 3 and 5.
 - When baking four cake layers at the same time, stagger pans so that one pan is not directly above another. For best results, place cake on front of upper rack and back of lower rack (See graphic at right). Allow 1" - 1 ½" (2,5 - 3cm).air space around pans.

- Converting your own recipe can be easy.
Choose a recipe that will work well in convection.
- Reduce the temperature and cooking time if necessary. It may take some trial and error to achieve a perfect result. Keep track of your technique for the next time you want to prepare the recipe using convection.

Tips for Solving Baking Problems are found on Page 31.

Foods recommended for Convection Bake mode:

Appetizers Biscuits Coffee Cakes

Cookies (2 to 4 racks) Yeast Breads

Cream Puffs

Popovers

Casseroles and One-Dish Entrees

Oven Meals (rack positions 1, 2, 3)

Air Leavened Foods (Soufflés, Meringue, Meringue Topped Desserts, Angel Food Cakes, Chiffon Cakes)



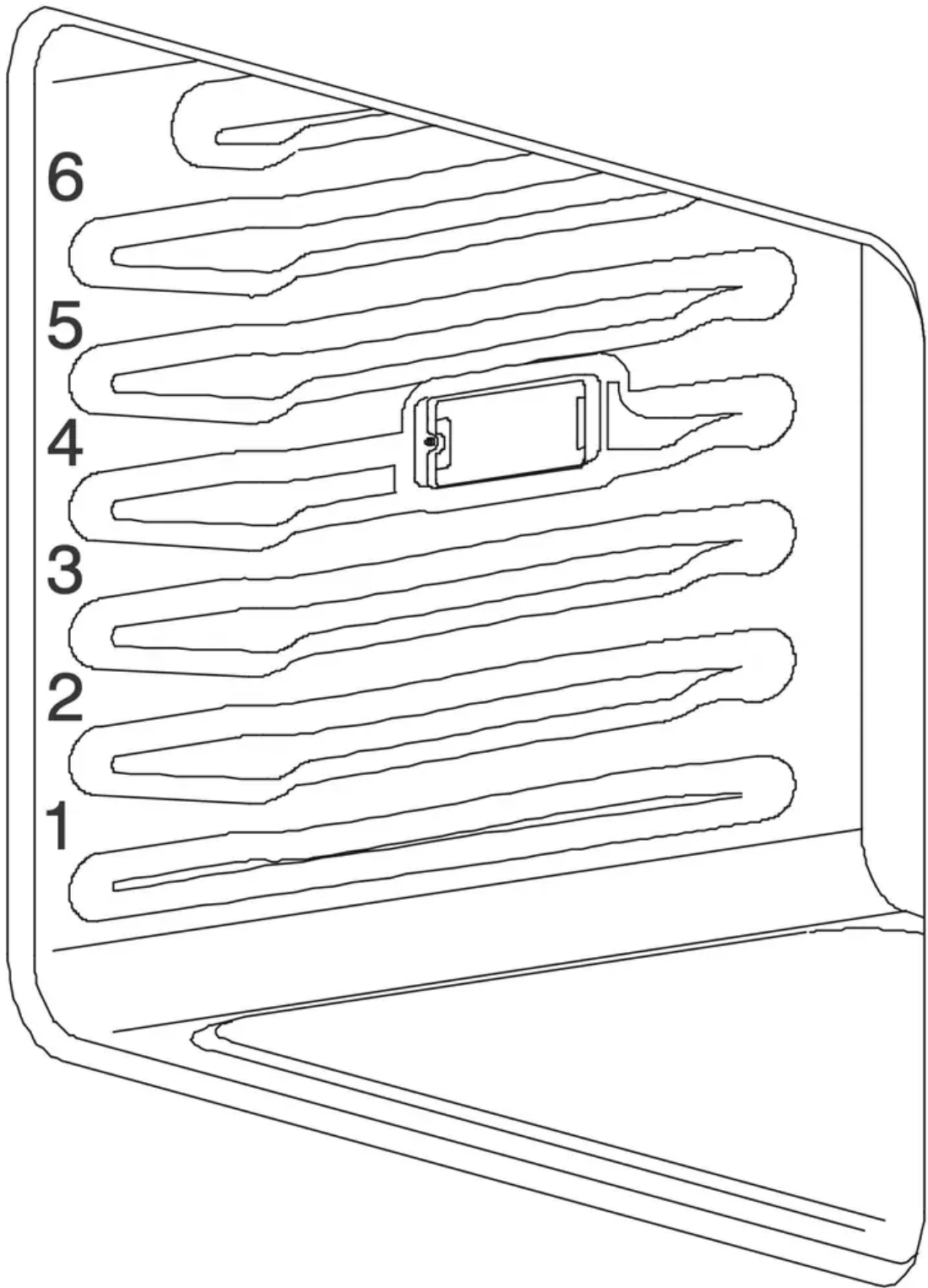

Rack position

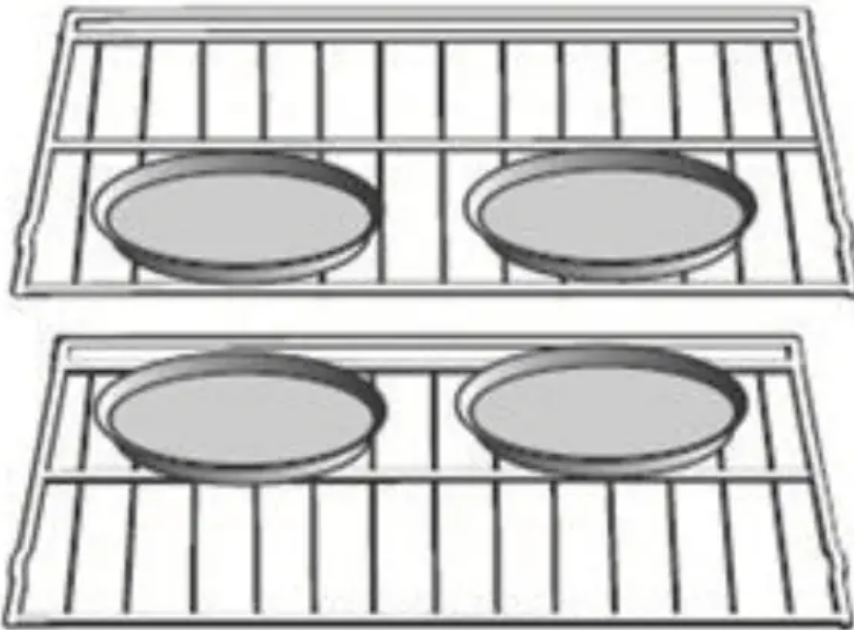

Rack 3

Rack 1

Multiple rack pan placement

Quick and easy recipe tips

Converting from standard BAKE to CONVECTION BAKE:

- Reduce the temperature by 25 °F (15 °C).
- Use the same baking time as Bake mode if under 10 to 15 minutes.
- Foods with a baking time of less than 30 minutes should be checked for doneness 5 minutes earlier than in standard bake recipes.
- If food is baked for more than 40 to 45 minutes, bake time should be reduced by 25%.

Convection Bake Chart

Reduce standard recipe temperature by 25 °F (15 °C) for Convection Bake.

Temperatures have been reduced in this chart.

This chart is a guide.

Follow recipe or package directions and reduce temperatures appropriately.

CONVECTION CAVITY

FOOD ITEM	RACK POSITION	TEMP. °F (°C) (PREHEATED OVEN)	TIME (MIN)
Cake			
Cupcakes	2	325 (160)	20-22
Bundt Cake	1	325 (160)	43-50
Angel Food	1	325 (160)	43-47
Pie			
2 crust, fresh, 9"	2	350-400 (175-205)	40-52
2 crust, frozen fruit, 9"	2	350 (175)	68-78
Cookies			
Sugar	2	325-350 (160-175)	9-12
Chocolate Chip	2	325-350 (160-175)	8-13
Brownies	2	325 (160)	29-36
Breads			
Yeast bread, loaf, 9x5	2	350 (175)	18-22
Yeast rolls	2	350-375 (175-190)	12-15
Biscuits	2	375 (190)	8-10
Muffins	2	400 (205)	17-21
Pizza			
Frozen	2	375-425 (190-220)	23-26
Fresh	2	450 (232)	15-18

DOUBLE CONVECTION CAVITY

FOOD ITEM	RACK POSITION	TEMP. °F (°C) (PREHEATED OVEN)	TIME (MIN)
Cake			
Cupcakes	2	325 (160)	16-18
Bundt Cake	1	325 (160)	37-43
Angel Food	1	325 (160)	35-39
Pie			
2 crust, fresh, 9"	2	350-400 (175-205)	35-45
2 crust, frozen fruit, 9"	2	350 (175)	68-78
Cookies			
Sugar	2	325-350 (160-175)	6-9
Chocolate Chip	2	325-350 (160-175)	8-13
Brownies	2	325 (160)	29-36
Breads			
Yeast bread, loaf, 9x5	2	350 (175)	18-22
Yeast rolls	2	350-375 (175-190)	12-15
Biscuits	2	375 (190)	6-8
Muffins	2	400 (205)	13-16
Pizza			
Frozen	2	375-425 (190-220)	23-26
Fresh	2	450 (232)	15-18



Convection Roast Tips and Techniques

- Preheat for Convection Roast.
- Roast in a low-sided, uncovered pan.
- When roasting whole chickens or turkey, tuck wings behind back and loosely tie legs with kitchen string.
- Use the 2-piece broil pan for roasting uncovered.
- Use the probe or a meat thermometer to determine the internal doneness on "END" temperature (see cooking chart).

- Double-check the internal temperature of meat/poultry by inserting meat thermometer into another position.
- When roasting a large roast or turkey, roasting pan may need to be rotated during roasting time. This will allow for more even cooking. Large birds may also need to be covered with foil (and pan roasted) during a portion of the roasting time to prevent overbrowning.

Quick and easy recipe tips: Converting from standard BAKE to CONVECTION ROAST:

- Temperature does not have to be lowered.
- Roasts, large cuts of meat and poultry generally take 10-20% less cooking time. Check doneness early.
- Casseroles or pot roasts that are baked covered in CONVECTION ROAST will cook in about the same amount of time.
- The minimum safe temperature for stuffing in poultry is 165 °F (75 °C).

After removing the item from the oven, cover loosely with foil for 10 to 15 minutes before carving if necessary increase the final foodstuff temperature by 5° to 10°F (3° to 6° C)

Convection Roast Chart

CONVECTION CAVITY

MEATS	WEIGHT (lb)	OVEN TEMP. °F (°C)	RACK POSITION	TIME (min. per lb)	INTERNAL TEMP. °F (°C)
Beef					
Rib Roast	4-6	325 (160)	2	16-20 18-22	145 (63) medium rare 160 (71) medium
Rib Eye Roast, (boneless)	4-6	325 (160)	2	16-20 18-22	145 (63) medium rare 160 (71) medium
Rump, Eye, Tip, Sirloin (boneless)	3-6	325 (160)	2	16-20 18-22	145 (63) medium rare 160 (71) medium
Tenderloin Roast	2-3	400 (205)	2	15-20	145 (63) medium rare
Pork					
Loin Roast (boneless or bone-in)	5-8	350 (175)	2	16-20	160 (71) medium
Shoulder	3-6	350 (175)	2	20-25	160 (71) medium
Poultry					
Chicken whole	3-4	375 (190)	2	18-21	180 (82)
Turkey, not stuffed	12-15	325 (160)	1	10-14	180 (82)
Turkey, not stuffed	16-20	325 (160)	1	9-11	180 (82)
Turkey, not stuffed	21-25	325 (160)	1	6-10	180 (82)
Turkey Breast	3-8	325 (160)	1	15-20	170 (77)
Comish Hen	1-1 ½	350 (175)	2	45-75 total	180 (82)
Lamb					
Half Leg	3-4	325 (160)	2	22-27 28-33	160 (71) medium 170 (77) well
Whole Leg	6-8	325 (160)	1	22-27 28-33	160 (71) medium 170 (77) well

DOUBLE CONVECTION CAVITY



MEATS	WEIGHT (lb)	OVEN TEMP. °F (°C)	RACK POSITION	TIME (min. per lb)	INTERNAL TEMP. °F (°C)
Beef					
Rib Roast	4-6	325 (160)	2	18-22	145 (63) medium rare
Rib Eye Roast, (boneless)	4-6	325 (160)	2	20-25	160 (71) medium
Rump, Eye, Tip, Sirloin (boneless)	3-6	325 (160)	2	18-22	145 (63) medium rare
Tenderloin Roast	2-3	425 (220)	2	20-25	160 (71) medium
				15-20	145 (63) medium rare
Pork					
Loin Roast (boneless or bone-in)	5-8	350 (175)	2	18-22	160 (71) medium
Shoulder	3-6	350 (175)	2	20-25	160 (71) medium
Poultry					
Chicken whole	3-4	375 (190)	2	20-23	180 (82)
Turkey, not stuffed	12-15	325 (160)	1	10-14	180 (82)
Turkey, not stuffed	16-20	325 (160)	1	9-11	180 (82)
Turkey, not stuffed	21-25	325 (160)	1	6-10	180 (82)
Turkey Breast	3-8	325 (160)	1	15-20	170 (77)
Comish Hen	1-1 ½	350 (175)	2	45-75 total	180 (82)
Lamb					
Half Leg	3-4	325 (160)	2	20-27	160 (71) medium
				25-32	170 (77) well
Whole Leg	6-8	325 (160)	1	20-27	160 (71) medium
				25-32	170 (77) well



Convection Broil (Grill) Tips and Techniques

- Place rack in the required position needed before turning on the oven.
- Use Convection Broil mode with the oven door closed.
- Do not preheat oven.
- Use the 2-piece broil pan.
- Turn meats once halfway through the cooking time (see convection Broil chart).

Convection Broil Chart

CONVECTION CAVITY

FOOD AND THICKNESS	RACK POSITION	BROIL SETTING °F (°C)	INTERNAL TEMP. °F (°C)	TIME SIDE 1 (MIN.)*	TIME SIDE 2 (MIN.)*
Beef					
Steak (1-½" or more)					
Medium rare	4	450 (235)	145 (65)	9-12	8-10
Medium	4	450 (235)	160 (71)	11-13	10-12
Well	4	450 (235)	170 (77)	18-20	16-17
Hamburgers (more than 1")					
Medium	4	480 (250)	160 (71)	8-11	5-7
Well	4	480 (250)	170 (77)	11-13	8-10
Poultry					
Chicken Quarters	4	450 (235)	180 (82)	16-18	10-13
Chicken Halves	3	450 (235)	180 (82)	25-27	15-18
Chicken Breasts	4	450 (235)	170 (77)	13-15	9-13
Pork					
Pork Chops (1¼" or more)	4	450 (235)	160 (71)	12-14	11-13
Sausage - fresh	4	450 (235)	160 (71)	4-6	3-5

* Broil and Convection Broil times are approximate and may vary slightly.

Cooking times are indicative and also depend on the thickness and the starting temperature of the meat before cooking .

DOUBLE CONVECTION CAVITY

FOOD AND THICKNESS	RACK POSITION	BROIL SETTING °F (°C)	INTERNAL TEMP. °F (°C)	TIME SIDE 1 (MIN.)*	TIME SIDE 2 (MIN.)*
Beef					
Steak (1-½" or more)					
Medium rare	4	450 (235)	145 (65)	11-13	10-12
Medium	4	450 (235)	160 (71)	15-17	13-15
Well	4	450 (235)	170 (77)	16-18	13-15
Hamburgers (more than 1")					
Medium	4	480 (250)	160 (71)	9-11	5-8
Well	4	480 (250)	170 (77)	11-13	8-10
Poultry					
Chicken Quarters	4	450 (235)	180 (82)	18-20	13-15
Chicken Halves	3	450 (235)	180 (82)	25-27	15-18
Chicken Breasts	4	450 (235)	170 (77)	14-16	10-14
Pork					
Pork Chops (1¼" or more)	4	450 (235)	160 (71)	13-15	12-14
Sausage - fresh	4	450 (235)	160 (71)	4-6	3-5

* Broil and Convection Broil times are approximate and may vary slightly.

Cooking times are indicative and also depend on the thickness and the starting temperature of the meat before cooking .

Broil (Grill) Tips and Techniques



- Place rack in the required position needed before turning on the oven.
- Use Broil mode with the oven door closed.
- Do not preheat oven.
- Use the 2-piece broil pan.
- Meats may be brushed with cooking oil or butter to prevent sticking.
- Turn meats once halfway through the cooking time (see Broil chart).

Grill Broil

FOOD AND THICKNESS	RACK POSITION	BROIL SETTING	INTERNAL TEMP. °F (°C)	TIME SIDE 1 (MIN.)*	TIME SIDE 2 (MIN.)*
Beef					
Steak (3/4"-1")					
Medium rare	5	5	145 (63)	5-7	4-6
Medium	5	5	160 (71)	6-8	5-7
Well	5	5	170 (77)	8-10	7-9
Hamburgers (3/4"-1")					
Medium	4	5	160 (71)	8-11	6-9
Well	4	5	170 (77)	10-13	8-10
Poultry					
Breast (bone-in)	4	4	170 (77)	10-12	8-10
Thigh (very well done)	4	3	180 (82)	28-30	13-15
Pork					
Pork Chops (1")	5	5	160 (71)	7-9	5-7
Sausage - fresh	5	5	160 (71)	5-7	3-5
Ham Slice (1/2")	5	5	160 (71)	4-6	3-5
Seafood					
Fish Filets, 1" Buttered	4	4	Cook until opaque & flakes easily with fork	10-14	Do not turn
Lamb					
Chops (1")					
Medium Rare	5	5	145 (63)	5-7	4-6
Medium	5	5	160 (71)	6-8	4-6
Well	5	5	170 (77)	7-9	5-7
Bread					
Garlic Bread, 1" slices	4	5		2-2,30	
Garlic Bread, 1" slices	3	5		4-6	

* Broiling and convection broiling times are approximate and may vary slightly

Cooking times are indicative and also depend on the thickness and the starting temperature of the meat before cooking .

Special Features

The Special Features function can be used to select the following special oven features:

1. **SAB => SABBATH MODE** (for religious faiths with "no work" requirements on the Sabbath).
2. **OFS => OVEN OFFSET** (used to calibrate the oven temperature).
3. **dEG => °UNIT** (used to select Fahrenheit or Celsius).
4. **Hr => CLOCK FORMAT** (used to set the time of day format as 12:00 AM/PM or 24:00).
5. **Set => PRESET TEMPERATURE** (it's possible to save the standard preset temperature per every cooking mode or to keep in memory the last used temperature).

To select special features, follow the steps below:

- Touch and hold [MENU] and [TIME] keys for at least 3 seconds. Clock time disappears and the following display is shown:

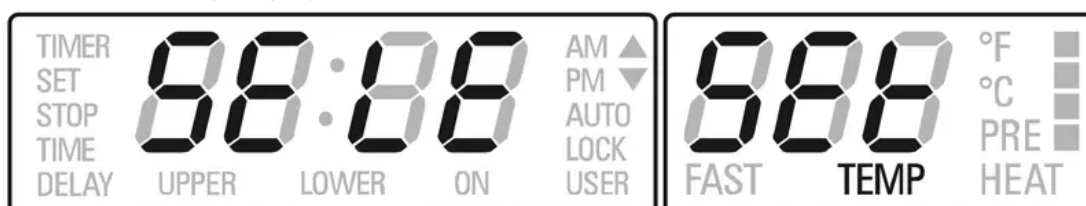

- Touch the [INC] or the [DEC] key to scroll all available options described above, until the desired one is found.
- Touch [MENU] key to edit the selected options.
- Change the value by means of [INC] or [DEC] keys.

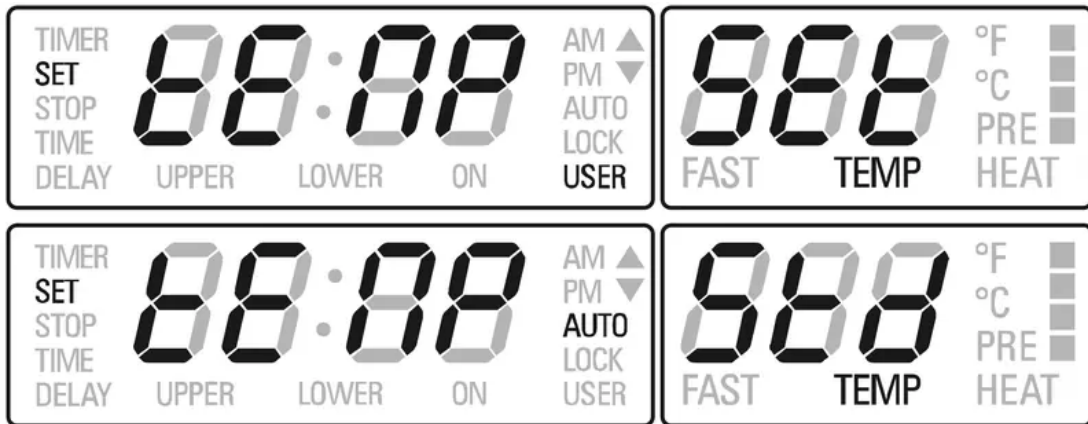

- In a double oven it's possible to set a different offset in each cavity. Select the cavity with UPPER/LOWER key.
- Touch the [MENU] key to confirm the option and go back to the selection menu or hold the key for 3 second to quit the User Option Menu and go back to the clock original screen.

Sabbath Mode Instruction

- Enter the user option menu holding [MENU] and [TIME] keys for 3 seconds. Scroll the option list (dEG, OFS, Hr, Sab), shown by the red temperature module, by pressing [INC]/[DEC], until Sabbath item is found.

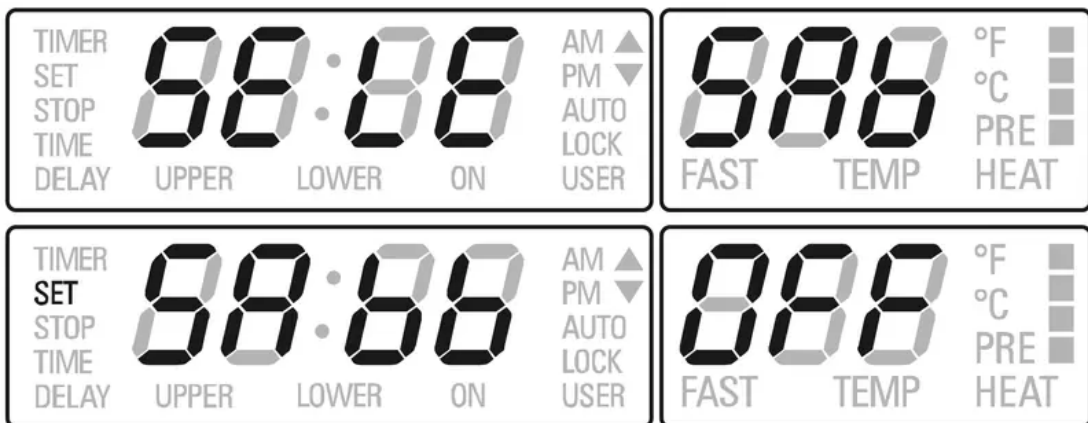

- Touch [MENU] to enter edit mode: the selected item switches to the green digits on the left and its status in the red digits field starts blinking.
- Touch again [INC]/[DEC] keys to set Sabbath mode ON or OFF (Default=OFF). Touch [MENU] to confirm and come back to the option list. Hold [MENU] key for 3 seconds to quit the selection menu and go back to normal operations.

- Once Sabbath mode is set, only BAKE and OFF positions are available in the cooking mode selector. Move the selector to BAKE then set the temperature to the desired value within 5 minutes.
- After 5 minutes, the temperature cannot be shown any more and the display appears as below: Sabbath mode is active. In a double oven, the upper/lower cavity indications are still available. Both triangle are on if both cavities are working.

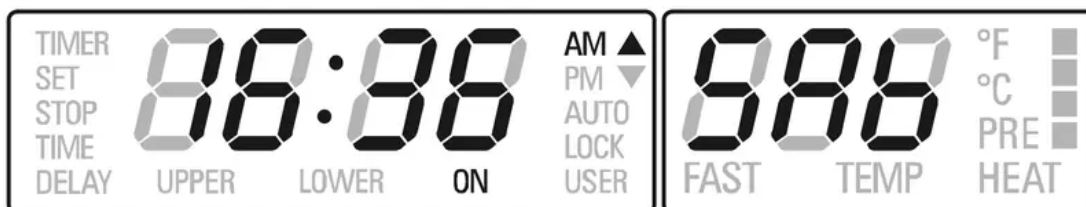

- Oven lights status cannot be changed during Sabbath time.
- Oven temperature can only be lowered but no information can be displayed.
- The cooling fan must run in Sabbath mode.
- Preheat lights are inhibited during Sabbath mode.
- The buzzer must always be silent, regardless of any fault, end of activity, etc.
- The meat probe can never be used in Sabbath mode.
- Maximum allowed cooking time must be 72 hours.
- The user is allowed to stop the oven manually, also during Sabbath, moving the cooking mode selector to OFF position.
- Heating elements cycling must not depend on the door switch status. Opening or closing the door must not switch the relays directly.

Care & Cleaning

The ovens feature a pyrolytic self-cleaning function that eliminates the difficult and time consuming manual scrubbing of the oven interior. During self-cleaning the oven uses very high temperature [approx. 470 °C (885 °F)] to burn away soil and grease. The fumes produced during this function of the oven are then filtered and expelled. You will note however, that a powder ash residue will be left on the bottom of the oven after completion of self-cleaning. Once the oven has cooled sufficiently the residue may be removed using a damp cloth or sponge. See the instructions on use of the self-clean (pyrolytic) function on page 27.

WARNING! Make sure all controls are OFF and the oven is cool before cleaning. Failure to do so can result in burns or electrical shock.

For parts of the oven other than the oven cavity the following cleaning methods are recommended:

- **Control Panel** - Use warm soapy water or spray glass cleaner to clean the control panel. With a soft cloth or sponge wash, rinse and dry the control panel thoroughly. DO NOT use abrasive cleaners or steel wool pads. These will damage the surface.

- **Stainless Steel** - To clean, use a standard cleaner designed for stainless steel. We recommend Stainless Steel Liquid Cleaner CSSL or Stainless Steel Pump Pack Cleaner CSSPP.
Follow manufacture instructions.
DO NOT USE ABRASIVE MATERIALS SUCH AS STEEL WOOL OR ROUGH SPONGES. THEY WILL SCRATCH THE SURFACE.
- **Front of Oven Door(s) and Handle(s)** - Use warm, soapy water or spray glass cleaner to clean the glass door surface.
With a soft cloth or sponge, rinse and dry the door front(s) and handle(s) thoroughly.
DO NOT use abrasive cleaners or steel wool pads. These will damage the surface.
- **Grill Pan and Rack(s)** - Use warm soapy water.
With a steel wool pad wash, rinse and thoroughly dry the pan and/or rack(s). DO NOT clean the grill pans or racks by leaving them in the oven when running the Self-Clean function.
- **Frame Outside Door Gasket Area** - Make sure oven is cool, then use warm soapy water. With a non-abrasive plastic scrubbing pad, clean the frame surface outside the door gasket area. This area must be cleaned by hand because the area outside the gasket does not get hot enough to burn off the soil (see Figure 6).
- **Door Outside Gasket Area** - Make sure oven is cool, then use warm soapy water. With a nonabrasive, plastic scrubbing pad clean the area outside the door gasket area. This area must be cleaned by hand because the area outside the gasket does not get hot enough to burn off the soil (see Figure 6).
- **Door glass** - Do not use harsh abrasive cleaners or sharp metal scrapers to clean the oven door glass since they can scratch the surface, which may result in shattering of the glass.

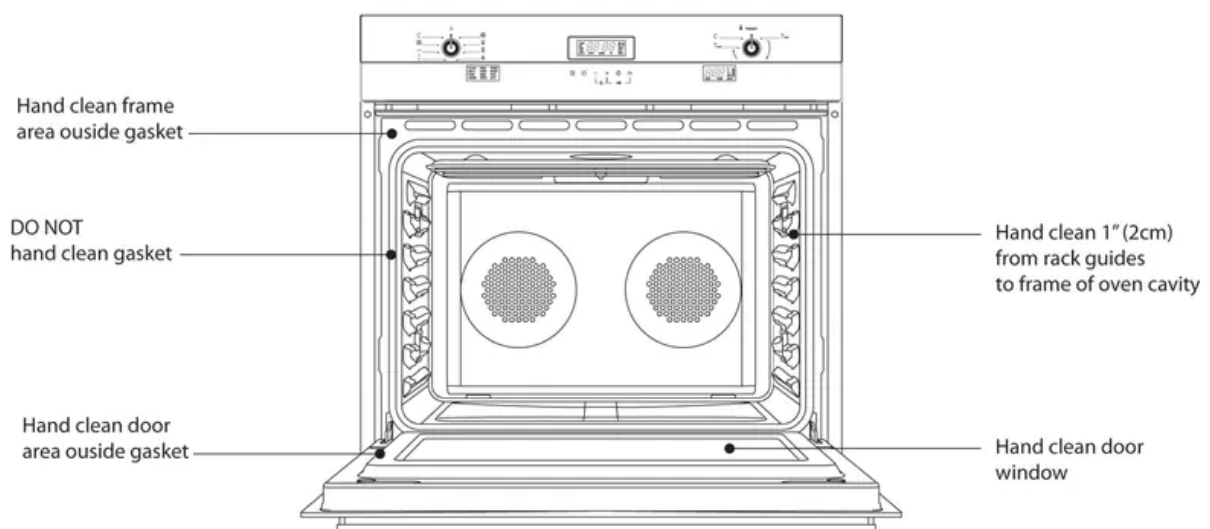

Self-Cleaning Function

- Only one oven at a time can be set to SelfClean.
- It is common to see smoke and/or an occasional flame-up during the Self-Clean cycle, depending on the content and amount of soil remaining in the oven.
If a flame persists, turn off the oven and allow it to cool before opening the door to wipe up the excessive food soil.
- The door latch is automatically activated after selecting the Self-Clean cycle.
The door lock symbol will appear in the display.
This ensures that the door cannot be opened while the oven interior is at clean temperatures.
- The oven light does not operate during this mode.
- During Self-Clean, the kitchen should be well ventilated to help eliminate odors associated with Self-Clean.
Odors will lessen with use.
- Three hours is the preset length of cleaning.
- The mode automatically stops at the end of the clean hours.
- When the oven heat drops to a safe temperature, the automatic door lock will release and the door can be opened.

Preparing the Oven for Self-Clean

1. Remove all utensils and bake ware.
2. Remove oven racks. If oven racks are left in the oven during the self-clean cycle, they will permanently lose the shiny finish and change to a dull dark finish.
See Care & Cleaning for proper care, see page 26.
3. Wipe up any soft soil spills and grease with paper towels.
Excess grease will cause flames and smoke inside the oven during self-cleaning.
4. Review illustration below.
Some areas of the oven must be cleaned by hand before the cycle begins.
They do not get hot enough during the cleaning cycle for soil to burn away.
Use a soapy sponge or plastic scrubber. Hand-clean the oven door edge, oven front frame and up to 1-½ " (2-3 cm) inside the frame with detergent and hot water.
Do not rub the gasket on oven. Hand clean the oven door window.
Rinse all areas thoroughly then dry.
5. Be sure oven interior lights are turned off and the light bulbs and lens covers are in place. See Page 30.

Setting the Self-Clean Mode

To Set the Self-Clean Mode

1. Touch [UPPER/LOWER] key to select the cavity to be cleaned, if the oven is a double.
2. Rotate both knobs into the clean position.
3. CLEAN & TIME appear.
4. The clean time is displayed automatically, its standard value is 3 hours.
5. At the end of the programmed cleaning time, the oven will automatically turn off.
6. To stop the cleaning mode at any moment, move one of the two knobs from the cleaning position.

Do not attempt to open the door while the door is locked. The "AUTO LOCK" writings will flash until the motor stops. When they are displayed, the door cannot be opened. Check that the door has been locked and will not open before starting the Self-Clean mode.

If door does not lock, rotate the cooking mode knob into the OFF position and do not start selfclean; phone for service.

If the door is in the open position when this mode is selected, the "AUTO LOCK" writings will flash until the door is closed. The latch doesn't move.

To Change the Cleaning Time

1. To change the setting from 3 hours, select either 2 hours for light soil or 4 hours for heavy soil immediately before starting.
2. To change the hours, touch the [TIME] key.
3. The hours will flash.
4. Use [INC] or [DEC] keys to change the value.
5. To change the minutes, touch the [TIME] key again.
6. The minutes will flash.
7. Use [INC] or [DEC] keys to change the value. Hold the key to change by 10 minutes steps.
8. Touch [TIME] or wait a few seconds to confirm the new value.

To Delay the Start of Cleaning

1. Follow steps 1 through 7 above.
2. Touch the [TIME] key and verify that "STOP TIME" appears on the display. The hours will begin flashing.
3. Use [INC] or [DEC] keys to change the stop time value.
4. To change the minutes, touch the [TIME] key, the minutes will flash.

5. Use [INC] or [DEC] keys to change the value. Hold the key to change by 10 minutes steps.
6. Touch [TIME] or wait a few seconds to confirm the new value.
7. The latch starts moving to lock the oven door, the display shows “DELAY”.
8. When the delay time expires, self-cleaning will start.
9. At the end of the programmed cleaning time, the oven will automatically turn off.
10. “End” will appear on the temperature display, “CLEAN” on the mode display and “TIME” on the clock display will start flashing until the [TIME] key is touched or the knob is moved to the OFF position.

In order to check the cleaning or the stop time during a delayed clean, simply touch the [TIME] key until “TIME” or “STOP TIME” writings are displayed.



Do-it-Yourself Maintenance Oven Door Removal

WARNING!

- Make sure oven is cool and power to the oven has been turned off before removing the door.
Failure to do so could result in electrical shock or burns.
- The oven door is heavy and fragile.
Use both hands to remove the oven door. The door front is glass.
Handle carefully to avoid breakage.
- Grasp only the sides of the oven door.
Do not grasp the handle as it may swing in your hand and cause damage or injury.
- Failure to grasp the oven door firmly and properly could result in personal injury or product damage.

To Remove Door

1. Open the door completely.
2. Lift up the hinge bracket (1).
3. Hold the door firmly on both sides using both hands and close the door.
4. Hold firmly; the door is heavy.
5. Place the door in a convenient location.

To Replace Door

1. Insert the upper arms (2) of both hinges into the slots (3). The recesses (4) must hook on the lips (5).
2. Move the hinge brackets (1) back down into position.
3. Close and open the door slowly to assure that it is correctly and securely in place.

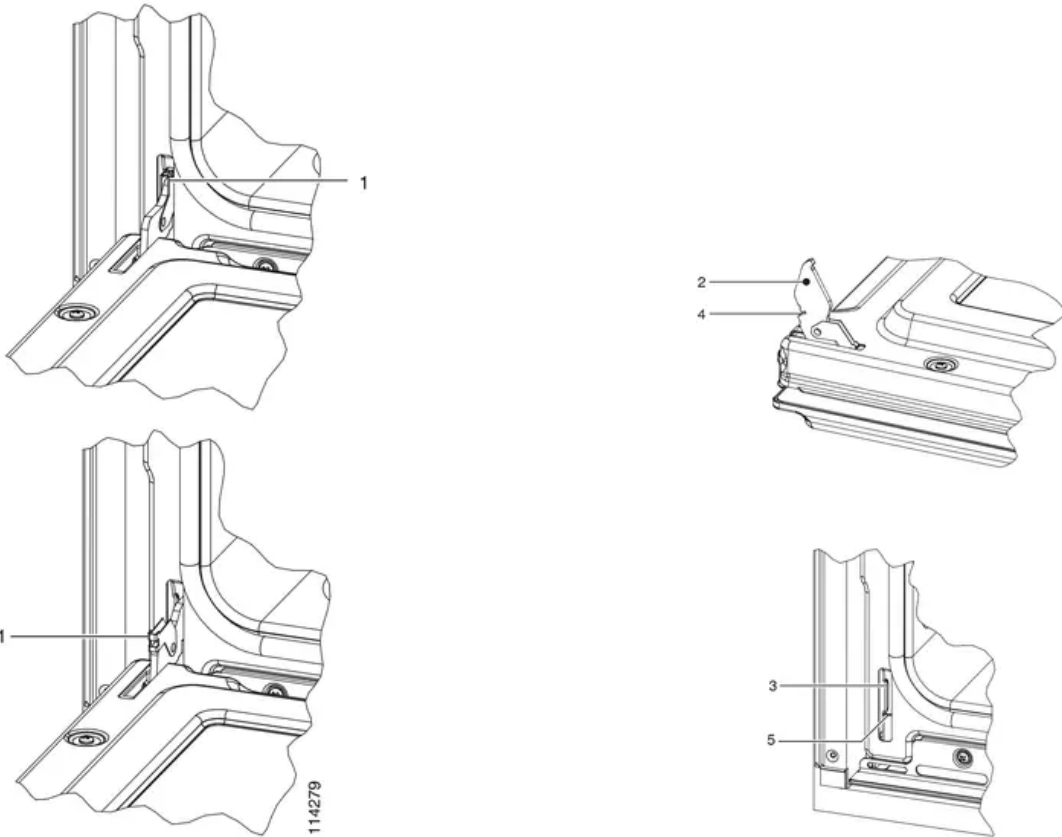

Replacing an Oven Light

- Each oven is equipped with halogen lights located in the lateral walls of the oven.
- The lights are switched on when the door is opened or when the oven is in a cooking cycle.
- The oven lights are not illuminated during SELF- CLEAN.
- Each light assembly consists of a removable lens, a light bulb as well as a light socket housing that is fixed in place. See figure on this page.
- Light bulb replacement is considered to be a routine maintenance item.

To Replace a Light Bulb

1. Read WARNING on this page.
2. Turn off power at the main power supply (fuse or breaker box).
3. In ovens with lateral racks, remove them by unscrewing the four screws.

4. Remove the lens to prise between screw and glass using a screw driver.
5. Remove the light bulb from its socket by pulling it.
6. Replace the bulb with a new one. Avoid touching the bulb with fingers, as oils from hands can damage the bulb when it becomes hot.
7. The bulb is halogen: use one with the same type checking Voltage and Wattage.
8. Replace the lens back on.
9. Replace the racks if it is provided with the oven model.

Turn power back on at the main power supply (fuse or breaker box).

WARNING!

- Make sure the oven and lights are cool and power to the oven has been turned off before replacing the light bulb(s).
Failure to do so could result in electrical shock or burns.
- The lenses must be in place when using the oven.
- The lenses serve to protect the light bulb from breaking.
- The lenses are made of glass.
Handle carefully to avoid breakage.
Broken glass could cause an injury.

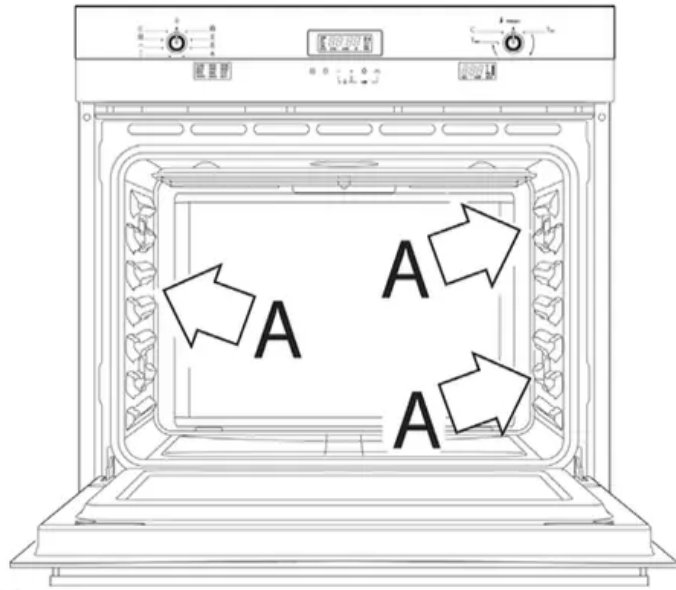

A

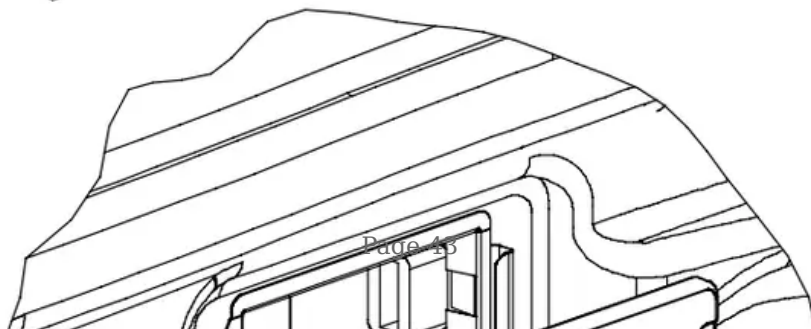
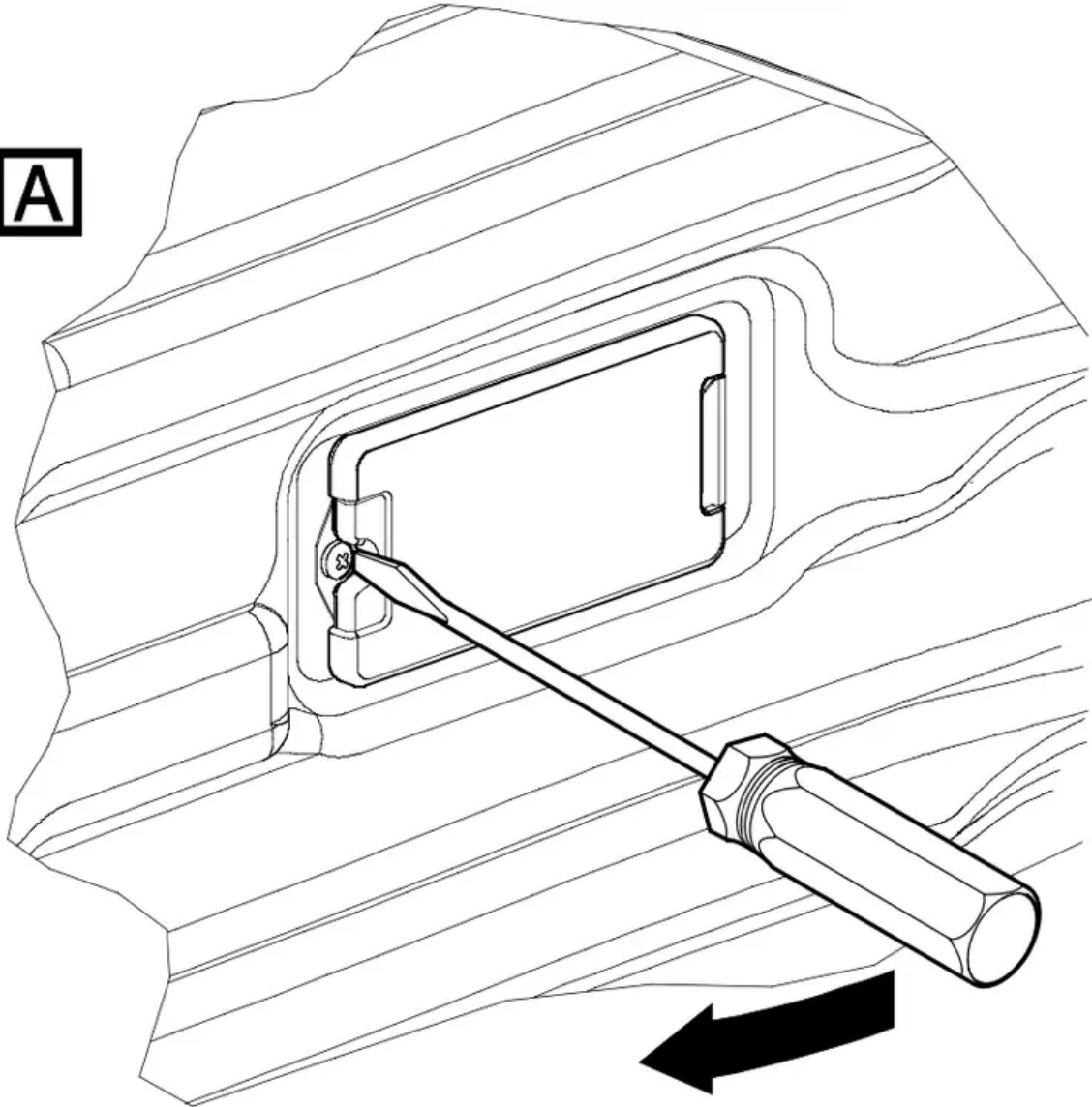

Solving Baking Problems

With either Bake or Convection Bake, poor results can occur for many reasons other than a malfunction of the oven.

Check the chart below for causes of the most common problems.

Since the size, shape and material of baking utensils directly affect the baking results, the best solution may be to replace old baking utensils that have darkened and warped with age and use.

Check the Baking Charts from page 17 to 23 for the correct rack position and baking time.

Solving Operational Problems

Before calling for service, check the following to avoid unnecessary service charges.



Oven Problem	Problem Solving Steps
F03 or F04 Error appears in the display window.	A problem with latch mechanism occurred. Remove power and turn it back on again after a few seconds. The oven should run a latch auto-test. If condition persists, note the code number and call an authorized service.
Other F__ Error appears in the display window.	Remove power and turn it back on again after a few seconds. If condition persists, note the code number and call an authorized service.
The oven display stay OFF	Turn off power at the main power supply (fuse or breaker box). Turn breaker back on. The oven should reset itself and will be operable. If condition persists, call an authorized service centre.
Cooling fan continues to run after oven is turned off	The fan turns off automatically when the electronic components have cooled sufficiently.
Oven door is locked and will not release, even after cooling	Turn the oven off at the circuit breaker and wait a few seconds. Turn breaker back on. The oven should reset itself and will be operable.
Oven is not heating	Check the circuit breaker or fuse box to your house. Make sure there is proper electrical power to the oven. Make sure the oven temperature has been selected.
Oven is not cooking evenly	Check oven calibration. Adjust calibration if necessary (see To Set Temperature, Page 14). Refer to cook charts for recommended rack position. Always reduce recipe temperature by 25 °F (15 °C) when baking with Convention Bake mode.
Oven temperature is too hot or too cold	The oven thermostat needs adjustment. See Calibrating Oven Temperature, Page 14.
Oven light is not working properly	Replace or reinsert the light bulb if loose or defective. See Page 30. Touching the bulb with fingers may cause the bulb to burn out.



Oven light stays on	Check for obstruction in oven door. Check to see if hinge is bent or door switch broken.
Cannot remove lens cover on light	There may be a soil build-up around the lens cover. Wipe lens cover area with a clean dry towel prior to attempting to remove the lens cover.
Oven will not Self-Clean properly	Allow the oven to cool before running Self-Clean. Always wipe out loose soils or heavy spill-over before running Self-Clean. If oven is badly soiled, set oven for a four-hour Self-Clean. See Preparing the Oven to Self-Clean, Page 27.
Clock and timer are not working properly	Make sure there is proper electrical power to the oven. See the Clock and Timer sections on Page 13
Excessive moisture	When using Bake mode, preheat the oven first. Convection Bake and Convection Roast will eliminate any moisture in oven (this is one of the advantages of convection).
Porcelain chips	When oven racks are removed and replaced, always tilt racks upward and do not force them to avoid chipping the porcelain.

If You Need Assistance or Service

If after reviewing Table 2 you decide that you do require service for your oven contact your nearest.

Do not attempt to repair the appliance yourself. Any work performed by unauthorized personnel may void the warranty.

You will find the model number and serial number information on the rating plate located on the frame, to the left of the oven opening (upper cavity for double oven).

Warning

This content is compiled from multiple sources and is provided for reference purposes only. It may not be complete or fully applicable to all situations. If you are unable to resolve your issue, please contact the product manufacturer or an authorized service provider for official support.