

Controls & Connections

Back of Sound Bar

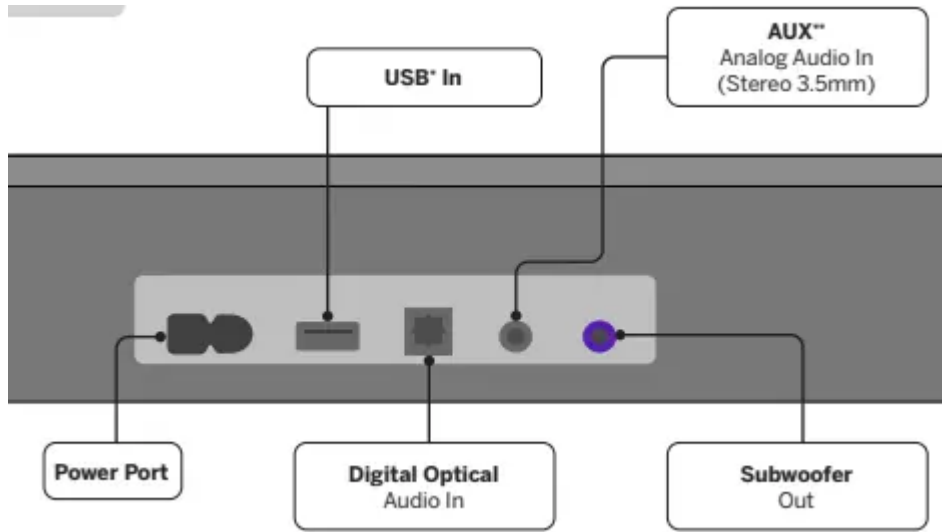

* Supports .WAV and .MP3 file format playback only.

**You can also use this port to connect a Voice Assistant device. See Connecting to a Voice Assistant on page 15 for more information.

Top of Sound Bar

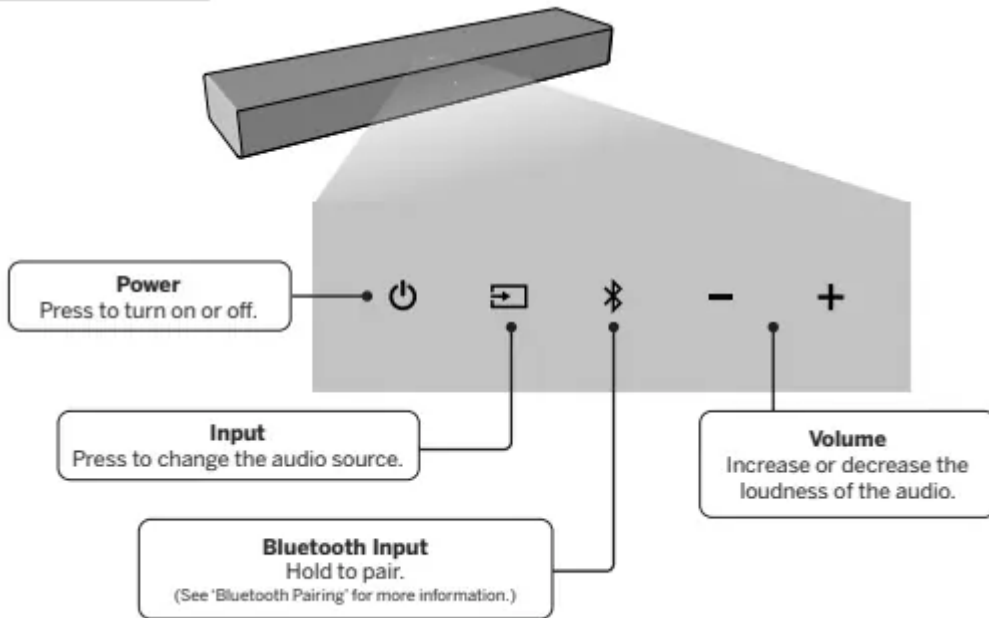

First-time Setup

1

Choose the best possible connection cable type and connect it to your TV.* (Not all cables are included.)

Back of Sound Bar

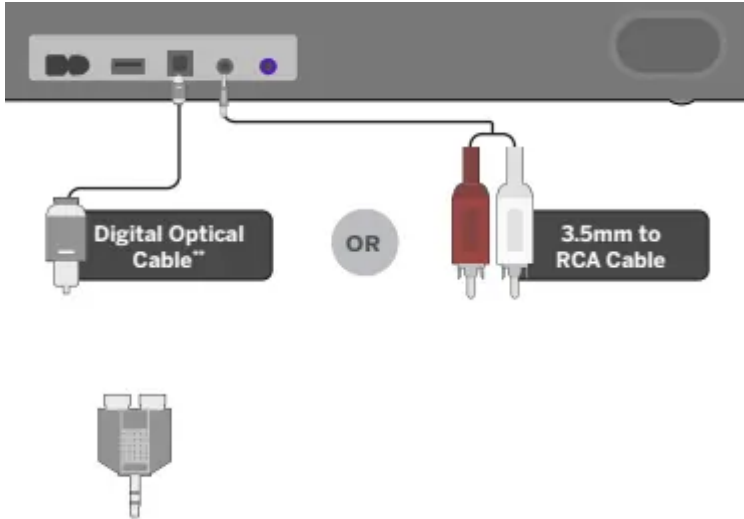

Optional: Use the included RCA adapter to connect to your TV if needed.

* Not all TVs have the audio outputs shown. To connect the sound bar directly to your other devices (Blu-ray player, game system, etc.) see your device's user manual.

**Some TVs do not pass through digital audio: When using the digital input, if there is no audio, try:

- setting the TV output to PCM, or
- connecting directly to your Blu-ray or other source.

DO NOT connect to Video Input R/L. Look for audio port OUT.

2

Connect the power cable to the sound bar AC IN as shown. Plug the power cable into an electrical outlet.

Back of Sound Bar

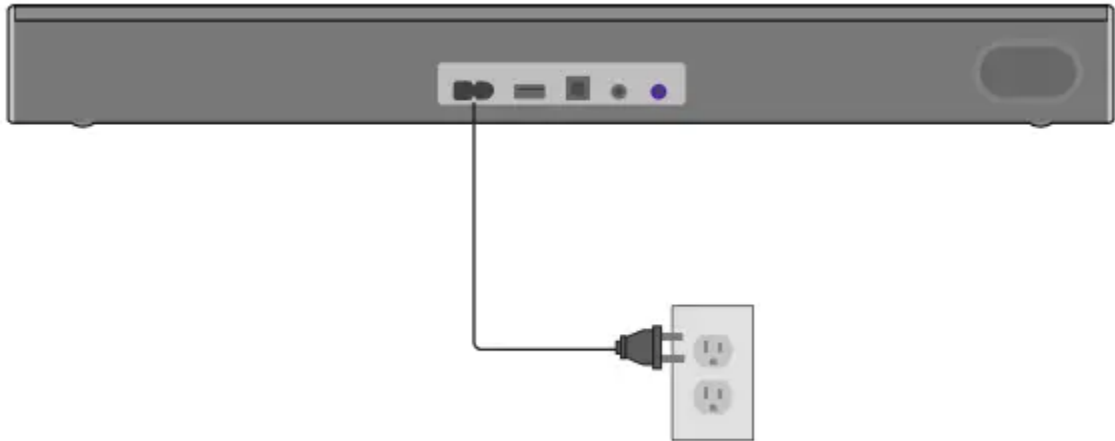

- 3** Remove the battery cover by gently sliding it away from the remote.

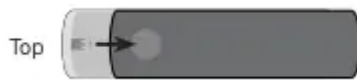

- 4** Insert the included batteries and gently slide the battery cover back into place.



When needed, VIZIO recommends replacing the batteries that came with this remote with two, new Duracell 'AAA' alkaline batteries.

- 5** After turning on both your TV and sound bar, it will automatically begin searching for an active input.* The LED indicator on the front of the sound bar will begin cycling in different colors through inputs until an audio source is detected.**



Tip: Pressing the INPUT button will stop the auto detect function.

You can press the INPUT button to switch between audio sources. For example, if you connected your TV to Optical, set the sound bar to Optical.

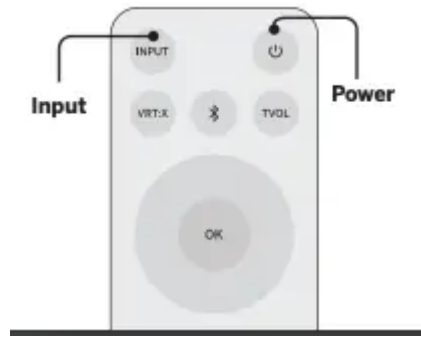

*Occurs only during first-time set up.

**Auto detect function only occurs once when the sound bar is first powered on. To enable this feature again, you must do a Factory Reset (see the Using Button Combinations on page 11 for more information) or press and hold the INPUT button for 4 seconds.

Using the Remote

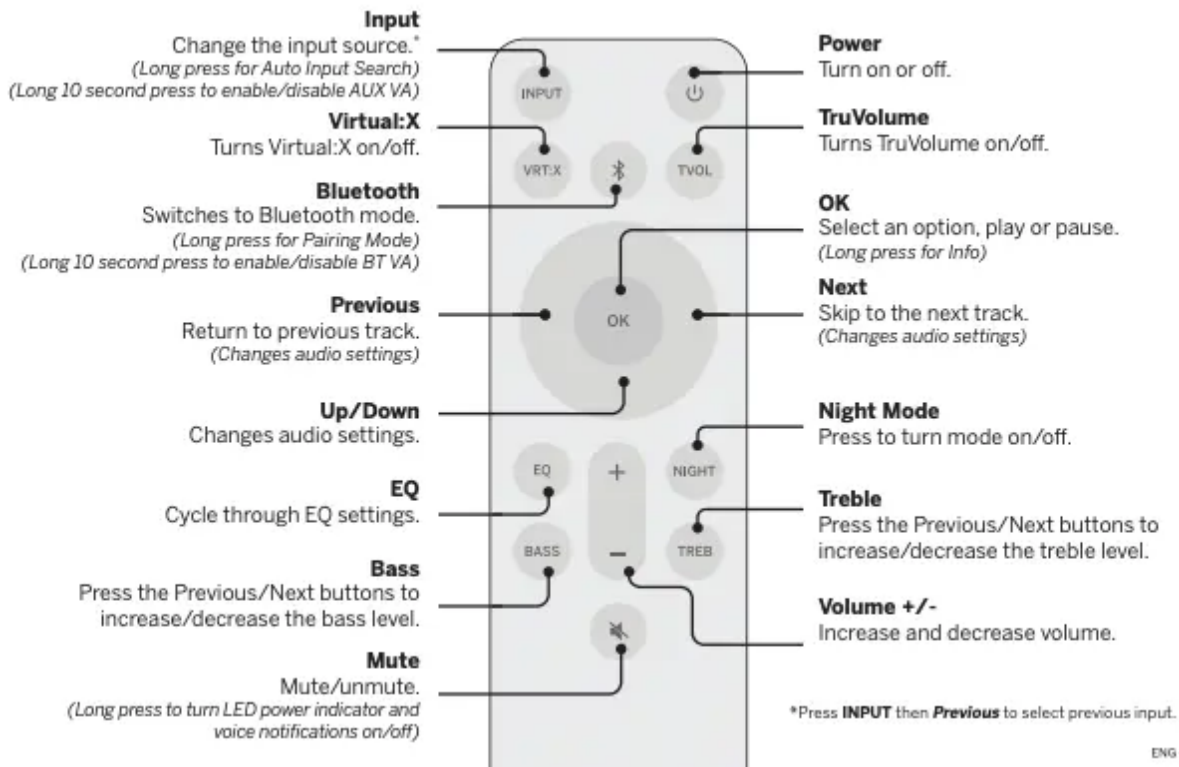

Proper Placement

For the best sound experience, position the sound bar as shown. The sound bar should be close to ear level.

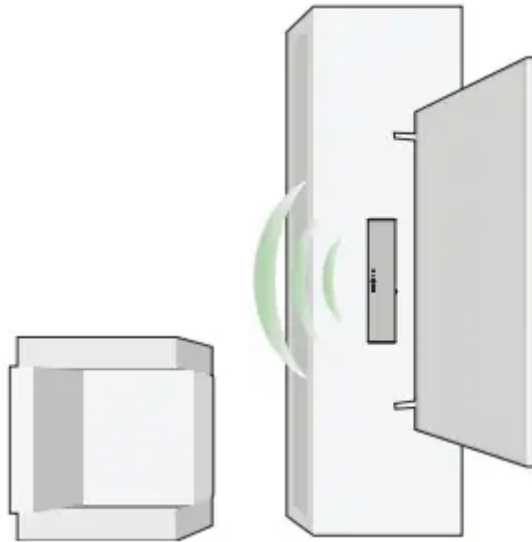

Sound bar is centered below the TV. (If your TV permits it, you can also slide the sound bar underneath the TV.)

Mode & Level Settings

The LED indicator will behave differently with each function.



LED Indicator is located here.

- **Input**  **The LED will blink a different color for each input.**

Press the INPUT button on the remote to cycle through the available inputs. Specific inputs will show a different LED color:

- AUX In: Green
- Digital Optical: Red
- Bluetooth: Blue
- USB: Magenta

Press and hold the INPUT button on the remote control for 3 seconds to enable the auto input detect function.

- **Bluetooth Pairing**  **The LED will blink blue when searching and turn solid once a device is paired successfully.**

Press and hold the  button on the remote. The sound bar will announce that it is "searching." It will be discoverable for 15 minutes. You can now search for the sound bar (VIZIO SB2020n) using your Bluetooth device. The sound bar will power down if no device is found.

Note: Set your Bluetooth device into pairing mode prior to the sound bar.

- **DTS TruVolume On/Off**  **High tone double beep: On, Low tone double beep: Off**

Press the TVOL button to enable/disable TruVolume. When enabled (On), TruVolume provides a consistent and comfortable volume level for a more enjoyable listening experience.

- **Virtual:X On/Off**  **High tone double beep: On, Low tone double beep: Off**

Press the VRT:X button to enable/disable Virtual:X. When enabled (On), all inputs will produce a virtual sound technology that simulates the effect of having overhead sound. When disabled (Off), all sources will playback in stereo.

- **Mute**  **If muted, the LED indicator will slowly pulse.**

Press the Mute button to mute/unmute the sound bar

- **Equalizer Mode**  **A voice notification will announce EQ modes as they are changed.**

Press the EQ button to cycle through equalizer settings: Movie, Music, Dialogue, and Game. Note: Movie mode is on by default.

- **Treble Levels**  **High tone double beep: Max level, Medium tone single beep: Mid level, Low tone double beep: Minimum level**

Press the TREBLE button then press the Next/Previous button to increase/ decrease the treble level. Note: Mid level is the default setting.

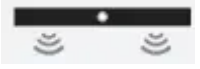
- **Bass Levels**  **High tone double beep: Max level ; Medium tone single beep: Mid level ; Low tone double beep: Minimum level**

Press the BASS button then press the Next/Previous button to increase/ decrease the bass level.

Note: Mid level is the default setting. If a subwoofer is connected, adjusting the bass level will also adjust the subwoofer level. Consult your subwoofer's user manual for additional adjustments that may optimize your listening experience.

- **Night Mode**  **On/Off High tone double beep: On ; Low tone double beep: Off**

Press the NIGHT button to enable/disable Night Mode. When enabled (On), the bass level will be lowered on the sound bar. If an external subwoofer is connected, bass level will also be lowered.

Note: Night mode will be OFF the next time the sound bar is turned on.

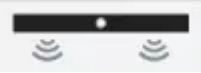
-  **Auto VA High tone beep: On ; Low tone beep: Off**

Depending on how you are connecting to a Voice Assistant device (sold separately), press and hold either the INPUT or Bluetooth button (on remote or sound bar) for 10 seconds to enable the voice assistant mode. Refer to Connecting to a Voice Assistant on page 16 for more information.

Note: Default setting is OFF.

Using Button Combinations

There are other functions that are triggered by different button combinations on the sound bar.

-  **Factory Reset LED will flash 3 times.**

Reset the sound bar to the factory default settings. To perform a Factory Reset, Press and Hold the Bluetooth (📶) and Volume Down (—) buttons for 5 seconds.

Note: This will erase all settings and preferences that you have set

-  **VIZIO TV Remote Control High tone double beep: On; Low tone double beep: Off**

Enable/disable the use of a VIZIO TV remote control to power on and adjust the volume of the sound bar. To enable/disable this function, Press and Hold the Power (⏻) and Volume Up (+) buttons for 5 seconds.

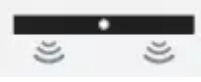
-  **Eco Power Mode High tone double beep: On; Low tone double beep: Off**

When the Eco Power mode setting is enabled, the sound bar will automatically power down after a period of inactivity. When disabled, the sound bar will remain powered on until you turn it off. To enable/disable this function, Press and Hold the Power (⏻) and Volume Down (—) buttons for 5 seconds.

Note: Eco Power Mode setting is OFF by default.



Speaker Test

Press and Hold the Bluetooth (📶) and Volume Up (+) buttons for 5 seconds. A voice will begin calling out each speaker beginning with left (left and right). If any of these are missing, check the connection and run the speaker test function again.



Programming the Sound Bar

You can program your sound bar to accept TV remote IR commands. You can then use your TV remote for simple commands.



- **Learn Volume Down**  **LED will flash yellow when learning and will turn solid when successful.**

Press and hold both the OK  and Volume Down  buttons on the remote to put the sound bar into learning mode. While the sound bar is in learning mode, press the Volume Down button on the TV remote control.

- **Learn Volume Up**  **LED will flash amber when learning and will turn solid when successful.**

Press and hold both the OK  and Volume Up  buttons on the remote to put the sound bar into learning mode. While the sound bar is in learning mode, press the Volume Up button on the TV remote control.

- **Learn Mute**  **LED will flash white when learning and will turn solid when successful.**

Press and hold both the OK  and Mute  buttons on the remote to put the sound bar into learning mode. While the sound bar is in learning mode, press the Mute button on the TV remote control.

Point both the sound bar and TV remotes towards the front of the sound bar when programming.



Turn off your TV speakers when programming your sound bar.

Bluetooth Pairing

To pair the sound bar with a Bluetooth device:

1. Press and hold the Bluetooth  button on the sound bar or remote control for three (3) seconds.

2. Search for the sound bar (VIZIO SB2020n) using your Bluetooth device. For more information, refer to the user documentation that came with the device.

3. Now you can play audio from your Bluetooth device. Volume can be controlled on both your source device and the sound bar.

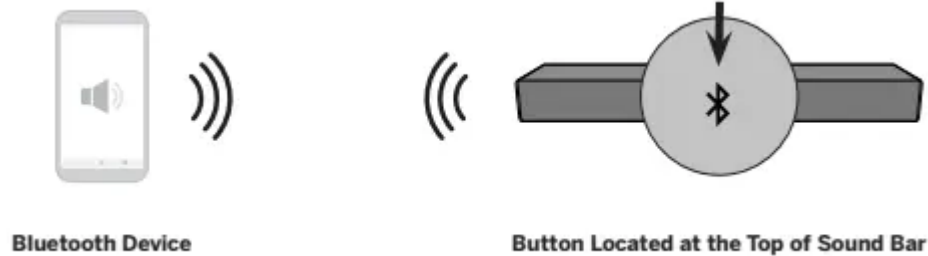

The LED indicator on the sound bar will turn blue and start blinking in pair mode. Once the device is paired, the LED indicator will stop flashing.

Using Bluetooth Mode

1. Your sound bar supports music streaming from devices with Bluetooth capability. (Device compatibility will vary, see your device's documentation for more information.)
2. Once you have paired your source device to the sound bar your device should remain paired (within range).
3. If the source is changed back to Bluetooth, any paired Bluetooth device will reconnect automatically.
4. If the input is changed, the Bluetooth device will disconnect (will stay connected if Auto VA BT is on).

Maximizing Signal

A Bluetooth signal has a range of up to 30 feet. Keep in mind that Bluetooth is a compressed audio format, so streamed music may lose some integrity when compared to a wired connection. Try the following if your sound quality is less than optimal:

- If you hear any break-up or disconnect while streaming music from your device, move the source device closer to the sound bar.
- Be sure that there are no solid obstructions in the line-of-sight between the sound bar and the source device.
- Other wireless devices can affect Bluetooth range, including wireless security cameras, wireless video baby monitors, cordless phones, and microwave ovens. Turning off or moving these devices may improve Bluetooth range.



Your sound bar is not equipped with a microphone, so it cannot operate as a hands-free device for a smartphone.



Reduce the volume levels on your device and on the sound bar before pressing Play. High volume levels can damage your hearing.

Connecting to a Voice Assistant

Your sound bar can connect to a Voice Assistant (VA) device through an AUX or Bluetooth connection. Once connected, your sound bar will now act as the VA speaker.

Features and Benefits:

- Voice Assistant Dedicated Input: VA can be active on the sound bar even if the sound bar is set to a different input with audio playing.
- Auto Muting: If playing audio from the sound bar, the VA will play over the original source audio for 10 seconds. If continued after the 10 seconds, the VA audio will mute the original source audio. Once the VA audio is stopped the original source audio will resume.



Make sure your sound bar is turned ON and Eco Power setting is turned OFF. Refer to Eco Power Mode on page 11 to disable.

Setup Tips:

- If the VA audio is too low, adjust the volume from the VA device.
- If the start of the response from the VA is cut off, enable “Start of Request” from your VA app settings.
- To enable/disable the VA function, press and hold either the INPUT or Bluetooth button on the remote for 10 seconds (depending on what connection you use). Refer to Auto VA on page 10 for more information.

Connecting to a Voice Assistant



Using the AUX Port to Connect

(If there is no AUX port on the VA device, use a Bluetooth connection instead.)

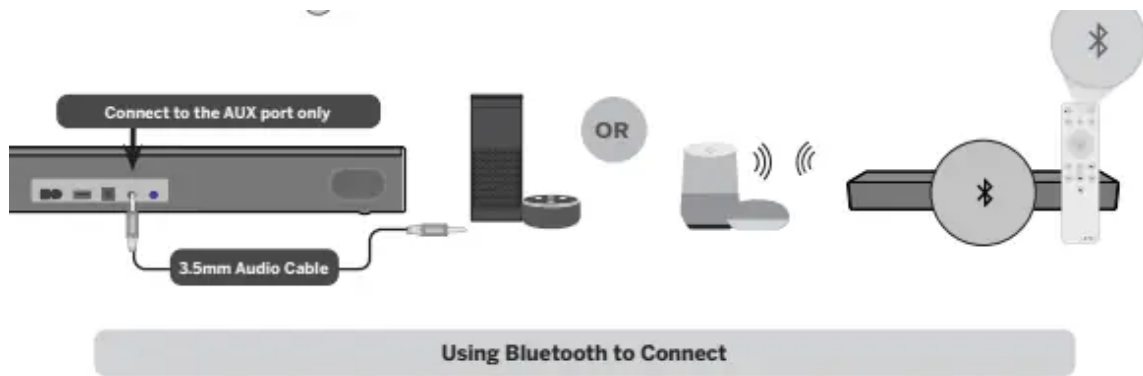
1. Use a 3.5mm audio cable to connect the AUX port on the sound bar to an AUX port on your voice assistant device.
2. Press and hold the INPUT  button on the remote for 10 seconds to enable AUX VA.



Using Bluetooth to Connect

1. Press and hold the Bluetooth  button on the sound bar or remote for three (3) seconds. Search for the sound bar (VIZIO SB2020n) using your VA device app. For more information, refer to the user documentation that came with the device.
2. After successful pairing, press and hold the Bluetooth  button on the remote for 10 seconds to enable Bluetooth VA.

Advanced Setup

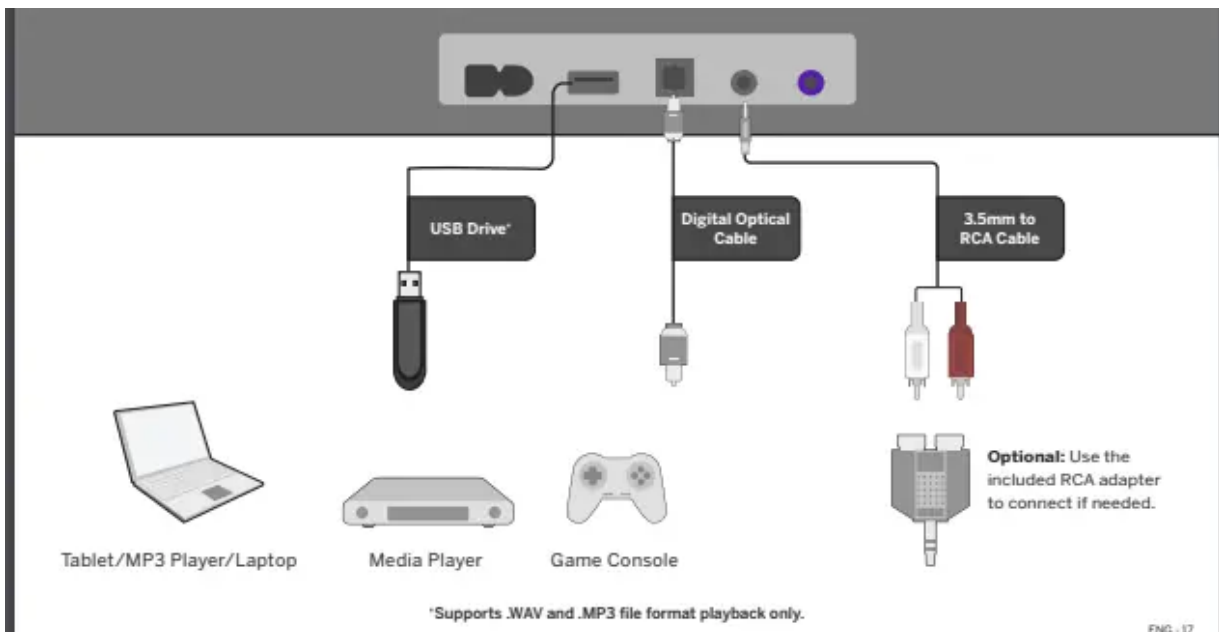

Help & Troubleshooting

There is no power.

- Press the POWER button on the remote control or on the top of your sound bar.
- Ensure the power cord is securely connected.

- Plug a different device into the electrical outlet to verify that the outlet is working correctly.

There is no sound.

- Increase the volume. Press VOLUME UP on the remote control or on the top of your sound bar.
- Press MUTE on the remote to ensure the sound bar is not muted.
- Press INPUT on the remote or on the top of your sound bar to select a different input source.
- When using the Digital Optical input, if there is no audio: (A) try setting the TV output to PCM or (B) connect directly to your Blu-ray/other source, some TVs do not pass through digital audio.
- On digital inputs, the input LEDs will flash rapidly if an unsupported format is present. Set the source to output PCM.
- Your TV may be set to variable audio output. Confirm that the audio output setting is set to FIXED or STANDARD, not VARIABLE. Consult your TV's user manual for more detailed information.
- If using Bluetooth, ensure that the volume on your source device is turned up and that the device is not muted.

I hear buzzing or humming.

- Ensure all cables and wires are securely connected.
- Connect a different source device (TV, Blu-ray player, etc) to see if the buzzing persists. If it does not, the problem may be with the original device.
- Connect your device to a different input on the sound bar.

The remote isn't working.

- Replace the remote batteries with new ones.
- Point the remote directly at the center of the sound bar when pressing a button.
- If using a Bluetooth connection, some of the buttons on the remote may not be supported by the streaming application.

Warning

This content is compiled from multiple sources and is provided for reference purposes only. It may not be complete or fully applicable to all situations. If you are unable to resolve your issue, please contact the product manufacturer or an authorized service provider for official support.

