

Refrigerator at a glance

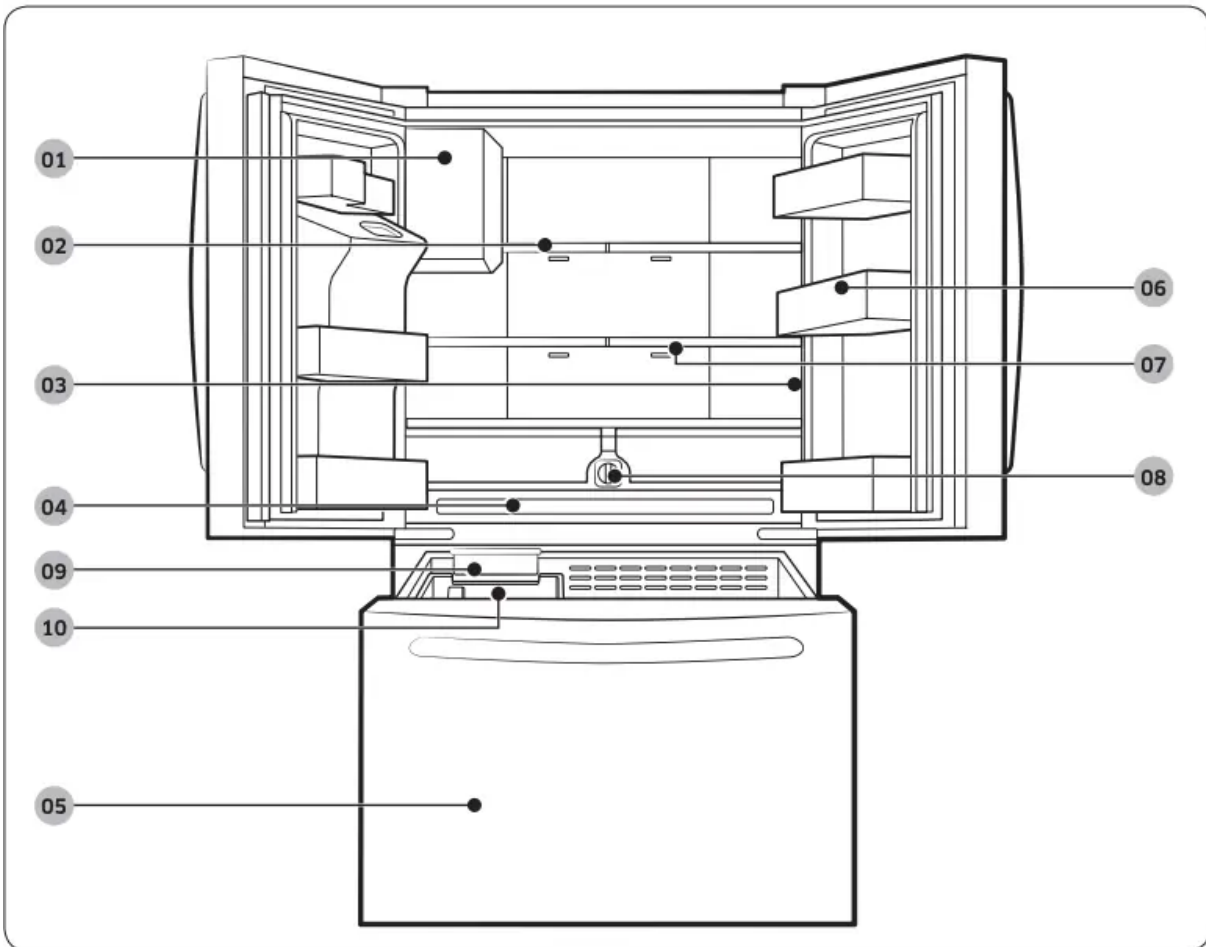

01 Auto Ice Maker

02 Foldable shelf

03 Main panel

04 Wide Pantry

05 Freezer

06 Door bins

07 Slide in shelf

08 Water filter

09 Ice Maker *

10 Ice bucket *

* applicable models only



NOTE

- For energy efficiency, keep all shelves, drawers, and baskets in their original positions.
- When closing the door, make sure the vertical hinged section is in the correct position to avoid scratching the other door.
- If the vertical hinged section is reversed, put it back into the correct position, and then close the door.
- Moisture may form at times on the vertical hinged section.
- If you close a door forcefully, the other door may open.
- When a door is opened, the interlock switch automatically disables the auger motor of the ice maker for safety reasons.
- If the internal or external LED lamp is out of order, contact a local Samsung service center.
- If the door is left open for too long, the top internal LED will blink. This is normal.

Operations

Main panel

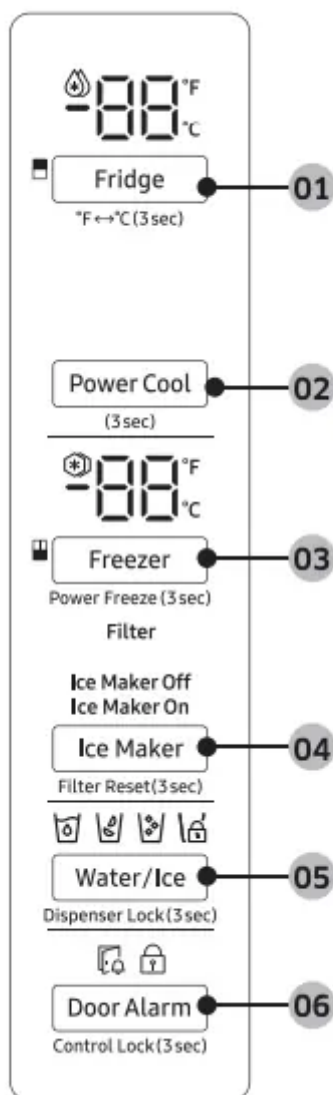

01 Fridge / $^{\circ}\text{F} \leftrightarrow ^{\circ}\text{C}$

02 Power Cool

03 Freezer / Power Freeze

04 Ice Maker / Filter Reset

05 Water/Ice / Dispenser Lock

06 Door Alarm / Control Lock

NOTE

- When you change the temperature on the panel, the panel displays the actual temperature inside the refrigerator until the temperature matches the temperature you set. Then, the panel displays the new set temperature. Note that it will take time for the

refrigerator to reach the new temperature. This is normal. During this time, you do not need to set the temperature again.

- To ensure optimal performance, we recommend setting the temperature to -19 °C for the freezer, and 3 °C for the fridge.
- The temperature in the refrigerator may rise if you open the door frequently or put a large amount of food into the refrigerator. If this happens, the temperature display blinks until the refrigerator returns to the specified temperature settings.
- If a communication error occurs between the temperature display and the main controller, this blinking continues for an extended time. Contact a local Samsung service center for technical assistance.
- The display of the main panel turns on only if the door is opened and turns off if the door is closed.
- If you set Control Lock on the main panel, the main panel locks automatically 1 minute after inactivity.

01 Fridge / °F ↔ °C (3 sec)

Fridge	<p>You can use the Fridge button to set the fridge temperature.</p> <ul style="list-style-type: none"> • Press Fridge repeatedly to select a desired temperature between 1 °C and 7 °C. <ul style="list-style-type: none"> - The temperature indicator displays the currently set or selected temperature.
°F ↔ °C	<p>You can also use the Fridge button to switch the temperature scale between Celsius and Fahrenheit. To switch the temperature scale, press and hold Fridge for 3 seconds to change the current temperature scale.</p>

02 Power Cool

Power Cool speeds up the cooling process at maximum fan speed. This is useful to quickly cool food that spoils quickly, or after the door is left open for some time. The fridge keeps running at full speed for several hours and then returns to the previous temperature. Press and hold Power Cool for 3 seconds.

The corresponding indicator () lights up, and the refrigerator will speed up the cooling process for you.

03 Freezer / Power Freeze (3 sec)

Freezer	The Freezer button can be used to set the freezer temperature, or to activate Power Freeze. Available temperatures are between -15 °C and -23 °C.
Power Freeze	<p>Power Freeze speeds up the freezing process at maximum fan speed. The freezer keeps running at full speed for 50 hours and then returns to the previous temperature.</p> <ul style="list-style-type: none"> • To activate Power Freeze, press and hold Freezer for 3 seconds. The corresponding indicator () lights up, and the refrigerator will speed up the freezing process for you. • To deactivate, press and hold Freezer for 3 seconds again. The freezer returns to the previous temperature setting. • To freeze large amounts of food, activate Power Freeze for at least 20 hours before putting food in the freezer. <p>NOTE Using Power Freeze increases power consumption. Make sure you turn it off and return to the previous temperature if you do not intend to use it.</p>

04 Ice Maker / Filter Reset (3 sec)



<p>Ice Maker</p>	<p>Press Ice Maker to turn the ice maker on or off. The ice maker has 2 indicators (Ice Maker On / Ice Maker Off) to indicate its operating status.</p> <ul style="list-style-type: none"> • When the ice maker operates, the corresponding indicator (Ice Maker On) turns on. • When the ice maker is turned off, the corresponding indicator (Ice Maker Off) turns on. In this case, ice making is disabled even if you press the Cubed Ice or Crushed Ice buttons on the dispenser panel. To enable ice making, you must turn the ice maker on. <p>NOTE If the ice maker is turned off, it will turn on if you press and hold the ice lever for more than 5 seconds.</p>
<p>Filter Reset</p>	<p>After about 6 months (and typically, about 1200 L of water), the Filter indicator blinks red for several seconds when you open the door, reminding you that the filter needs to be replaced.</p> <p>When this happens, replace the filter, and then press and hold Ice Maker for 3 seconds. The filter lifecycle will be reset and the Filter indicator turns off.</p> <p>NOTE</p> <ul style="list-style-type: none"> • Some regions have relatively large amounts of lime in their water. This can reduce the lifecycle of the filter. In these areas, you will have to replace the water filter more often than specified above. • If water is not dispensing properly, the water filter is most likely clogged. Replace the water filter.

05 Water/Ice / Dispenser Lock (3 sec)



Water/Ice	You can dispense chilled water, cubed ice, or crushed ice. To dispense, press Water/Ice. The corresponding indicator turns on.
Dispenser Lock (Dispenser panel / Dispenser lever)	<p>To prevent use of the dispenser panel buttons and the dispenser lever, press and hold Water/Ice for more than 3 seconds. If you press and hold the button again for more than 3 seconds, the dispenser lock will be deactivated.</p> <p>NOTE</p> <ul style="list-style-type: none"> • The Dispenser Lock on the dispenser panel does not affect the controls on the main panel. To lock the main panel, use the Control Lock function on the main panel. • If you press Water/Ice for 3 seconds when both control lock and dispenser lock are active, you will deactivate both control lock and dispenser lock.

06 Door Alarm / Control Lock (3 sec)

Door Alarm	<p>If the door is left open for more than 2 minutes, an alarm will sound and the alarm indicator will blink. You can toggle the alarm on and off by pressing Door Alarm. The alarm is enabled by factory default.</p> <p>If the door is left open for 5 minutes, internal lights (in the fridge and freezer) will blink for 10 seconds and then turn on. The whole process will be repeated every minute for 5 minutes. This is to alert hearing-impaired users that a door is open. Note that this function is normal.</p>
Control Lock	<p>To prevent accidental setting changes, press and hold Door Alarm for 3 seconds. The main panel will be disabled and the Lock indicator () will turn on.</p> <p>When Control Lock is on, the indicator blinks if any button on the main panel is pressed.</p> <p>If you press and hold the button again for more than 3 seconds, Control Lock will be deactivated.</p> <p>However, Control Lock will be reactivated if no button is pressed within 1 minute.</p> <p>NOTE Control Lock on the main panel does not affect the dispenser. The dispenser operates independently and so does the dispenser lever. To lock the dispenser and the dispenser lever, use the Dispenser Lock function.</p>

Dispenser panel

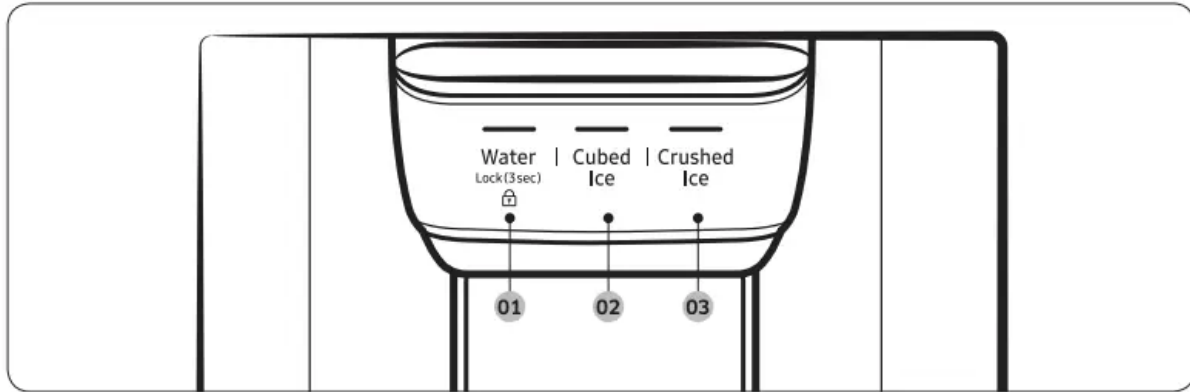

01 Water / Lock

02 Cubed Ice

03 Crushed Ice

01 Water / Lock (3 sec)

<p>Water</p>	<p>To dispense chilled water, press Water. The corresponding indicator turns on.</p>
<p>Lock (Dispenser panel / Dispenser lever)</p>	<p>To prevent the use of the dispenser panel buttons and the dispenser lever, press and hold Water for more than 3 seconds.</p> <p>If you press and hold the button again for more than 3 seconds, the dispenser lock will be deactivated.</p> <p>When dispenser lock is on, the indicator blinks if any button on the dispenser panel is pressed or the dispenser lever is pressed.</p> <p>NOTE</p> <p>The Lock on the dispenser panel does not affect the controls on the main panel. To lock the main panel, use the Control Lock function on the main panel.</p>

02 Cubed Ice

<p>Cubed Ice</p>	<p>Press Cubed Ice to dispense cubed ice. The corresponding indicator turns on.</p>
-------------------------	---

03 Crushed Ice

<p>Crushed Ice</p>	<p>Press Crushed Ice to dispense crushed ice. The corresponding indicator turns on.</p>
---------------------------	---

Special features

Water/Ice dispenser

Using the dispenser, you can dispense water with or without ice.

The water dispenser offers 3 options: chilled water, cubed ice, and crushed ice. To dispense chilled water, press Water on the dispenser panel. Put a water glass under the dispenser, and then push the dispenser lever.

To dispense water with ice

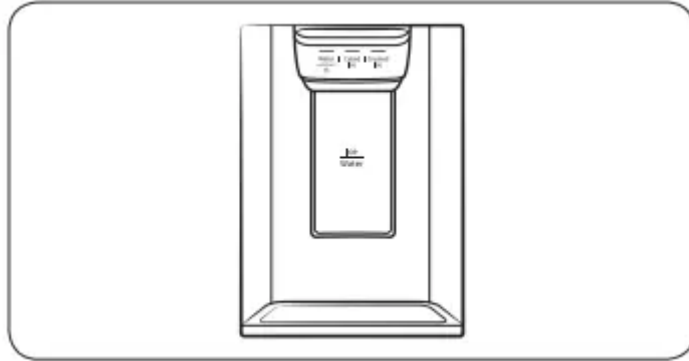

1. With the Ice Maker enabled, press Cubed Ice or Crushed Ice to select the ice type.
2. Put a water glass under the dispenser, and then push the dispenser lever with the glass. Ice will be dispensed from the dispenser.
3. Press Water to select water.
4. Push the dispenser lever with the glass. Water will be dispensed from the dispenser

NOTE

- The dispenser will stop dispensing if you keep pushing the dispenser lever for about 1 minute. To dispense more water, release and push the lever again.
- Make sure the glass is in line with the dispenser to prevent the dispensed water from spilling out.
- If you do not use the water dispenser for 2-3 days, the dispensed water may have an abnormal smell or taste. This is not a system failure. Discard the first 1-2 glasses of water.

Ice maker

The refrigerator has a built-in ice maker that automatically dispenses ice so that you can enjoy filtered water with cubed or crushed ice.

Ice making

After you have installed your refrigerator and plugged it in, follow these instructions to ensure proper ice making and to keep the ice bucket full of ice:

1. Let the refrigerator operate for at least 24 hours to ensure optimal performance.
2. Dispense the first 4 to 6 ice cubes into a glass.
3. Wait another 8 hours and dispense another 4 to 6 ice cubes.
4. Then, wait another 16 hours and dispense the first glass-full of ice.

NOTE

- If you consume all the ice at once, you must wait 8 hours before dispensing the first 4 to 6 cubes. This ensures that the ice bucket is filled with ice properly.
- Ice cubes generated rapidly may look white, which is normal.

Diagnosis

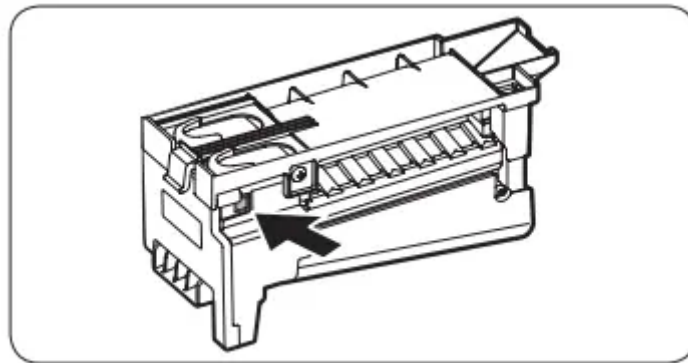

If ice does not dispense, first check the ice maker.

1. Press Test on the side of the ice maker. You will hear a chime (ding-dong) when you press the button.
2. You will hear another chime if the ice maker is operating properly.

CAUTION

- If the ice making chime rings repeatedly, contact your waterline installer or a local Samsung service center.
- Do not press Test repeatedly after the ice tray is filled with ice or water. Water may overflow or ice may jam.
- Do not put food in the ice bucket. The frozen food may damage the ice maker, especially when you open or close the door.
- When the refrigerator recovers power after a power failure, the ice bucket may contain a mix of melted and jammed ice cubes, which can prevent the ice maker from working properly. To prevent this, make sure to empty the ice bucket so the ice bucket can refill with fresh, loose ice cubes.

- Do not put fingers or any objects into the dispenser outlet or the ice maker. This can cause physical injury or property damage.
- When reinserting the ice maker tray, make sure that the tray is properly centered at the entrance. Otherwise, the tray can get stuck.

If You Turn the Ice Maker Off

If you press and hold Ice Maker for more than 3 seconds to turn the ice maker off, make sure to remove all ice cubes from the ice bucket. Remaining ice cubes may clump together, making it difficult to remove them.

To remove the ice bucket, see the Ice bucket (applicable models only) section on page 54.

NOTE

- Removal of the ice bucket does not affect the thermal and mechanical performance of the refrigerator.

Water clouding

Water supplied to the refrigerator flows through a core alkaline filter. During this filtering process, the water pressure of the water increases and the water becomes saturated with oxygen and nitrogen. This causes the water to look misty or cloudy temporarily when dispensed. This is normal and the water will look clear after a few seconds.

Maintenance

Handling and care

Ice bucket (applicable models only)

If you do not dispense ice for an extended period, ice may form clumps inside the bucket. If this happens, remove and empty the ice bucket.

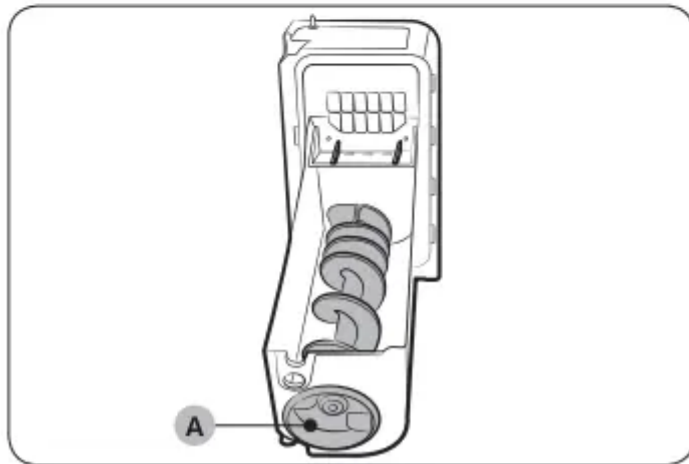
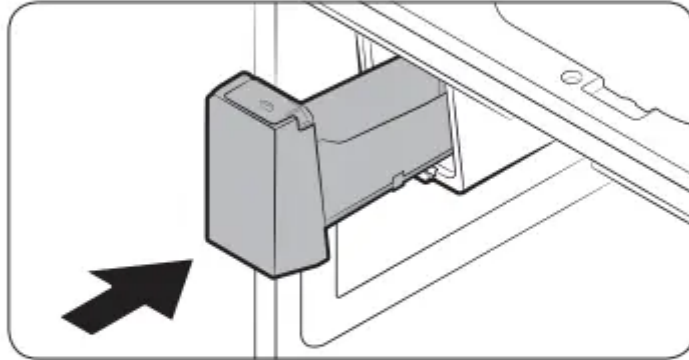
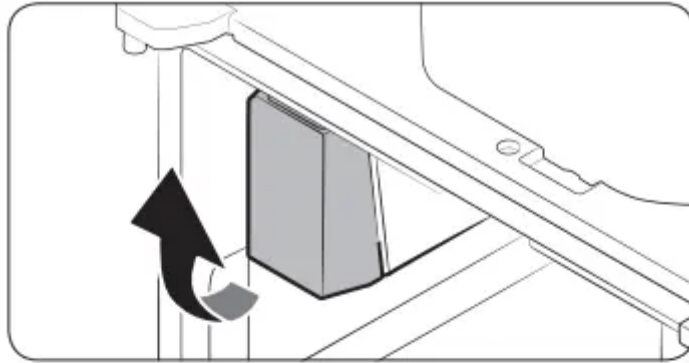

1. To remove the ice bucket, gently lift it up, and then pull it out slowly while holding the bottom of the bucket with one hand and the side with the other hand.
2. Empty the bucket.
3. When done, put the bucket back into position. If the bucket does not fit in, turn the helix screw 90 degrees, and then try again.

If the ice bucket is not firmly inserted, turn the Helix (A) 90 degrees, and then try again.

CAUTION

- Do not apply excessive force to the bucket cover. The cover may break.
- Do not forcefully close the door. Water may spill over the ice maker.
- To prevent injury, make sure to clean up any ice or water that has fallen on the floor.

- To prevent accidents or injury, do not let children play with the water dispenser or the ice maker.
- Do not put your hand or an object into the ice chute. This may cause physical injury or product damage.
- Use only the provided ice bucket. Third-party ice buckets may cause a system failure.

NOTE

- The water pressure required for ice making is between 206 to 827 kPa.
- Noise from the ice maker as it produces ice during the ice making process is normal.
- While the door is open, neither the ice maker nor the water dispenser operates.

Fridge shelves

The appearance of the shelves differs by model.

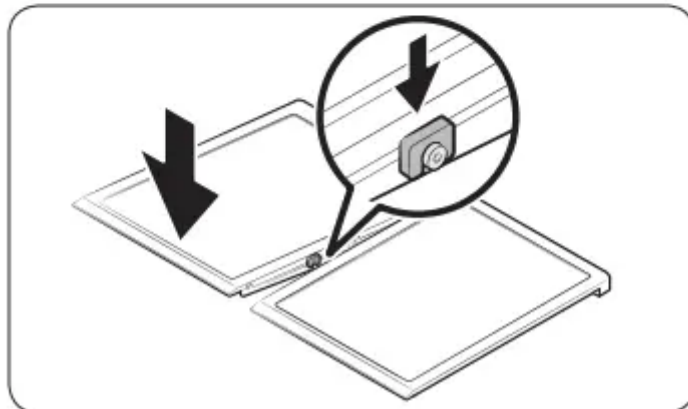
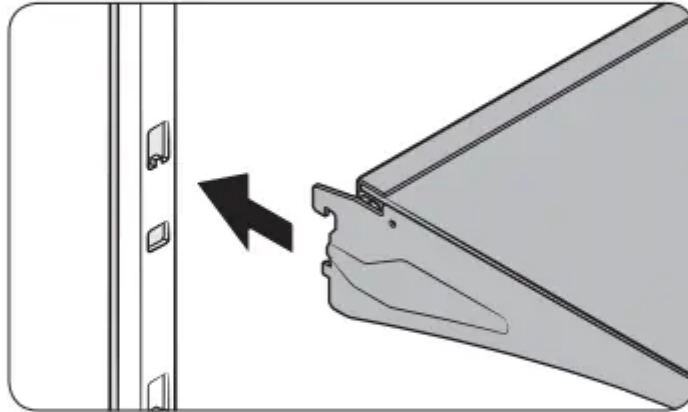
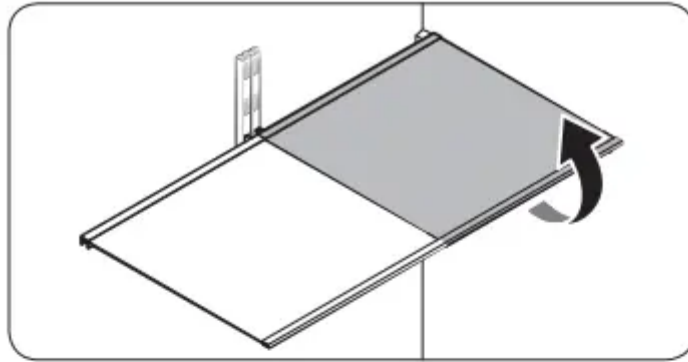

- To remove a shelf, fully open the corresponding door. Hold the front of the shelf, and then gently lift up and slide out.

NOTE

Do not lift up the shelf fully when removing or reinserting the shelf. The rear wall of the fridge room can be dented.

- To reinsert, hold the shelf at an angle so the front is higher than the back, and then insert the top hook into the top shelf notch. Then, lower the shelf and insert the bottom shelf hook into the bottom shelf notch.

CAUTION

- The tempered glass shelves are heavy. Use caution when removing them.

- The shelf must be inserted correctly. Do not insert upside down.
- Glass containers may scratch the surface of glass shelves.

Slide in shelf

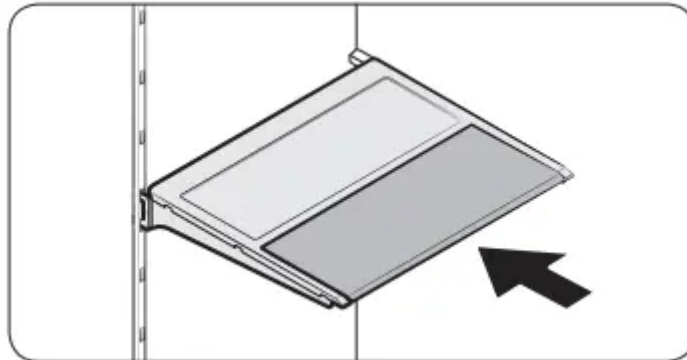

You may slide-in the front half of the slide-in shelf to store more tall items. Gently pull the front half of the shelf in order to use it as a whole shelf again.

Foldable shelf

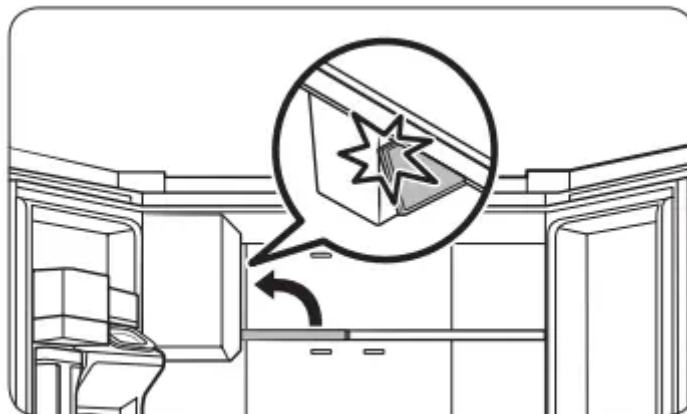

The foldable shelf gives you more room in the fridge for tall items.

- To fold, push the front area of the shelf upward.

CAUTION

Do not lift up quickly or twist the foldable shelf to take out food under it. It may fall off.

Door bins

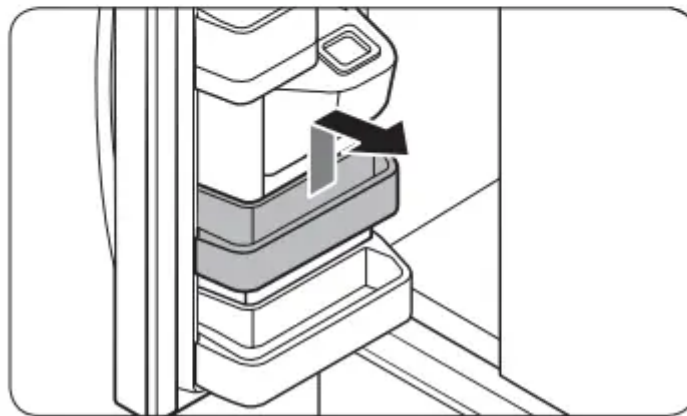
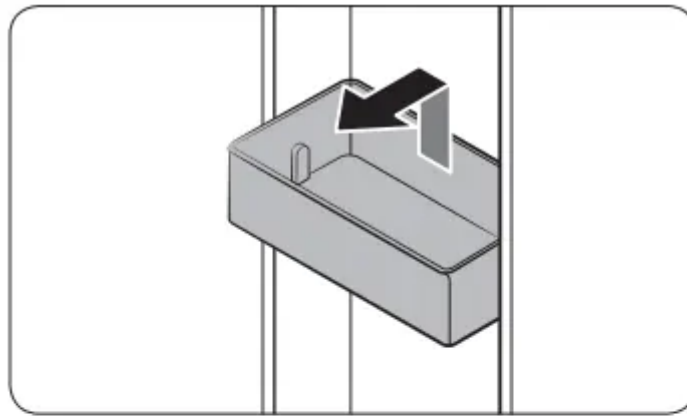

- To remove the door bin, hold the front sides of the bin, and then gently lift up to remove.
- To reinsert, insert the door bin slightly above its final location making sure that the back of the bin is against the door. Hold the rear of the door bin with both hands, and then press down so that it fits snugly.

CAUTION

- Do not remove a bin that is filled with food. Empty the bin beforehand.
- Use caution when opening the door if the bottom bin contains larger bottles, which may fall over.
- Do not allow children to play with the bins. Sharp corners of the bin may cause injury.

Fridge drawers

Vegetable / fruit drawers

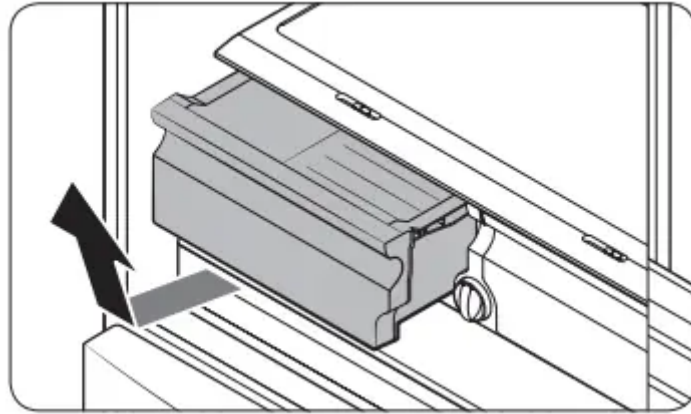

Gently lift up the front of the drawer and slide out.

- We recommend that you remove the door bins before removing the drawer. This is to prevent damage to the door bins.
- To reinsert, insert the drawer into the frame rails and then slide inward.

Wide Pantry

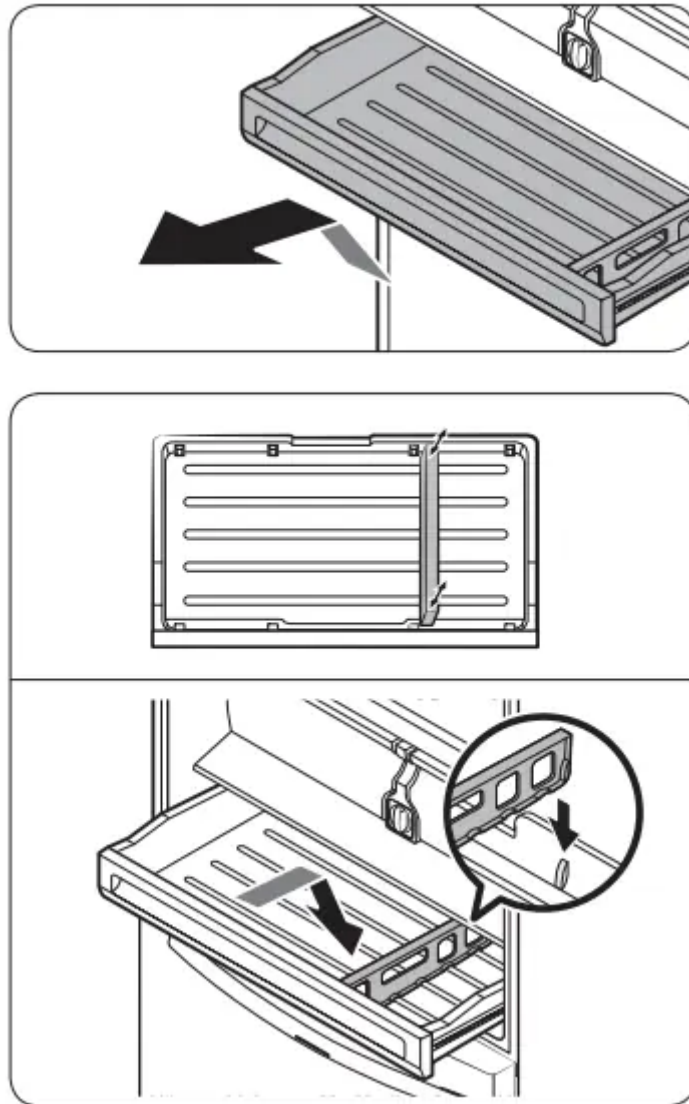

- To remove, fully open the Wide Pantry. Then, slightly lift the front side and pull straight out.
- To reinsert, push the rails to the back of the refrigerator. Then, place the Wide Pantry onto the rails and slide it back until it is in place.
- To remove the divider, lift the front side of the divider to unhook it from the wall, and then pull the divider out.
- To reinsert the divider, hook the back of the divider over the rear wall, and then push the divider down.

Freezer baskets

Lower ice bucket (applicable models only)

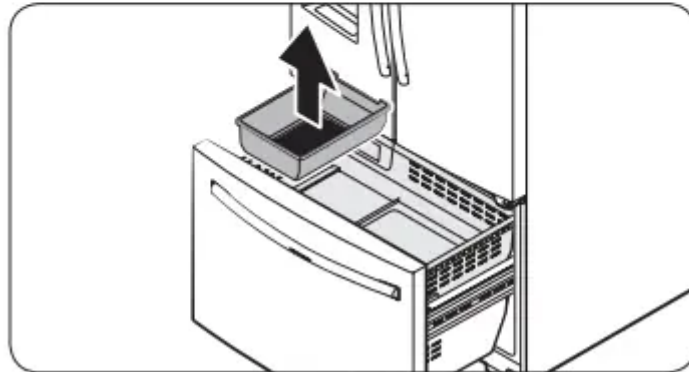
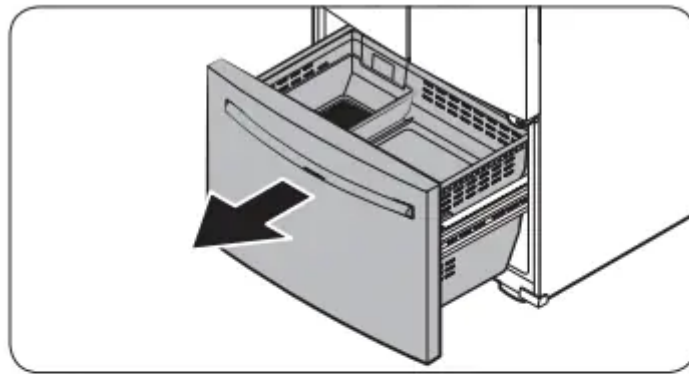

1. Fully open the freezer drawer.
2. Lift the lower ice bucket to remove.

Upper basket

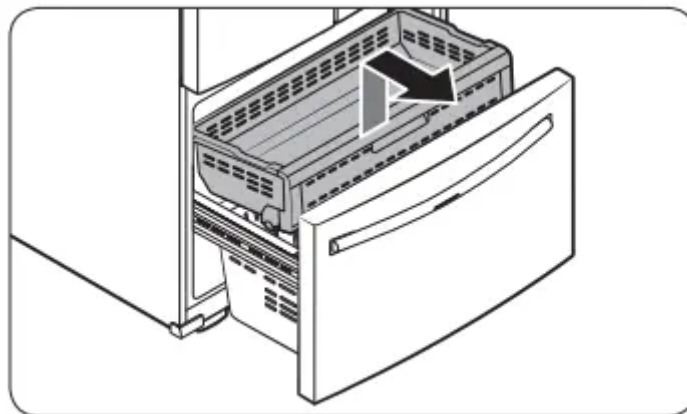

- To remove, fully slide open the freezer drawer. Lift up the front of the upper basket and pull to remove.
- To reinsert, align the front wheels of the upper basket with the end of the lower basket. Slide the upper basket to the front

Lower basket

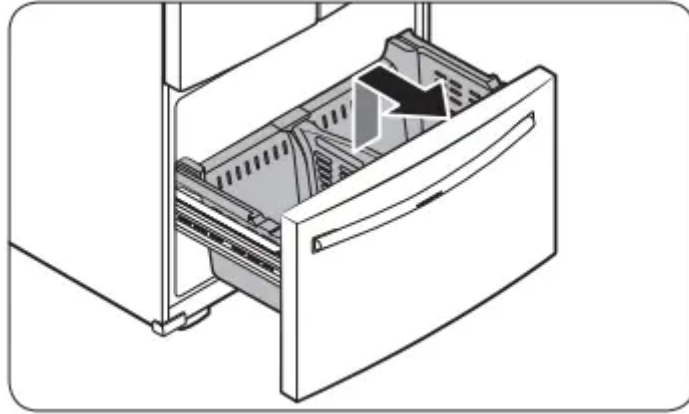

- To remove, first remove the upper basket. Then, tilt up the front of the lower basket to pull out.
- To reinsert, put the basket onto the rail assembly rear side first.

CAUTION

- Do not twist the basket when removing or reinserting the basket. The basket can be scratched.
- To prevent physical injury, property damage, or suffocation, keep children away from freezer baskets that have been removed.
- Do not remove the divider.
- Put the wheels of the upper basket on the end of the rails of the lower basket. Then, slide the upper basket all the way to the front. Otherwise, the drawer will not open or close properly, which will cause frost to build up.

Freezer basket divider (Type A, applicable models only)

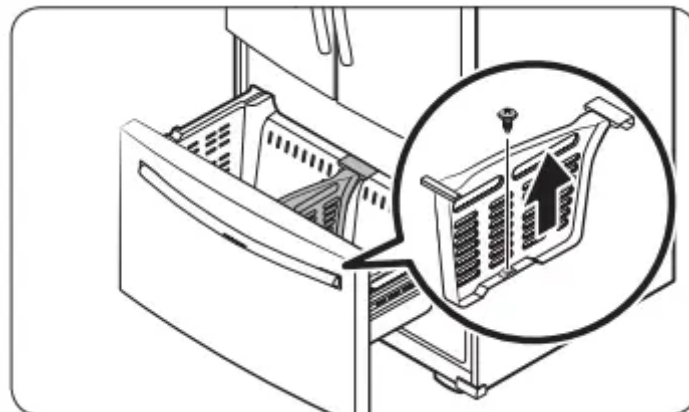

Loosen and remove the screw from the lower side of the divider. Then, pull straight up to remove the divider.

Freezer basket divider (Type B, applicable models only)

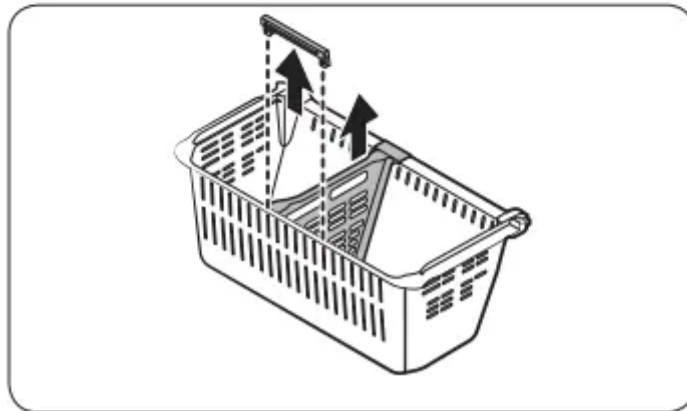
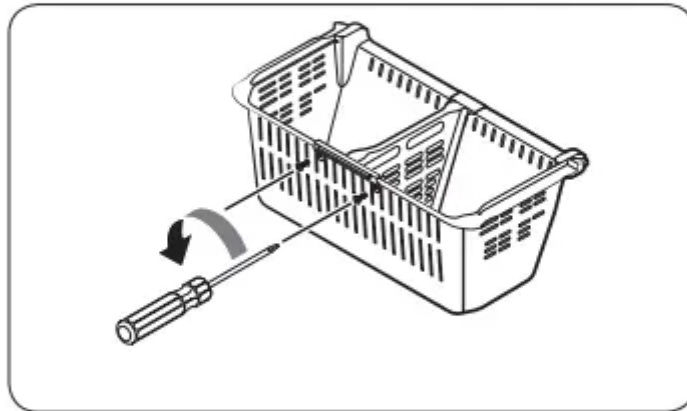
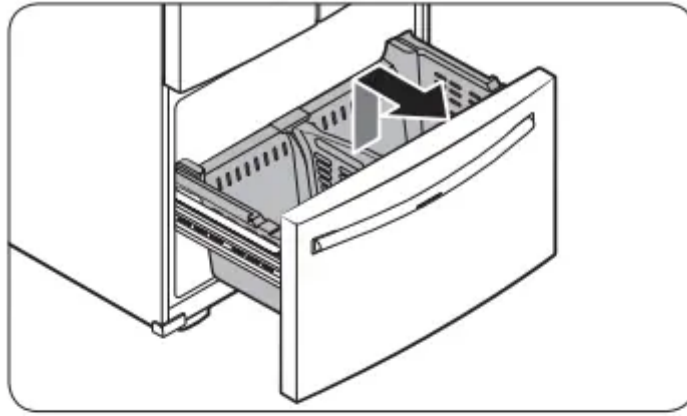

1. Remove the lower basket.
2. Use a Phillips screwdriver to unscrew the two screws affixing the rear fixer at the rear side of the basket.
3. Pull the rear fixer and the divider upward to remove.

Cleaning

Interior and exterior

WARNING

- Do not use benzene, thinner, home/car detergent, or Clorox™ to clean the refrigerator. They may damage the surface of the refrigerator and cause a fire.

- Do not spray water onto the refrigerator. This may cause electric shock.

Regularly use a dry cloth to remove all foreign substances such as dust or water from the power plug terminals and contact points.

1. Unplug the power cord.
2. Use a moistened, soft, lint-free cloth or paper towel to clean the refrigerator's interior and exterior.
3. When done, use a dry cloth or paper towel to dry well.
4. Plug in the power cord.

Ice / Water dispenser

CAUTION

When crushed ice is selected, some residual ice chips may collect in the ice chute. To prevent this, remove the residual ice from the chute using a soft, clean cloth.

Rubber seals

If the rubber seals of a door become dirty, the door may not close properly and reducing refrigerator performance and efficiency. Use a mild detergent and damp cloth to clean the rubber seals. Then, dry well with a cloth.

Rear panel

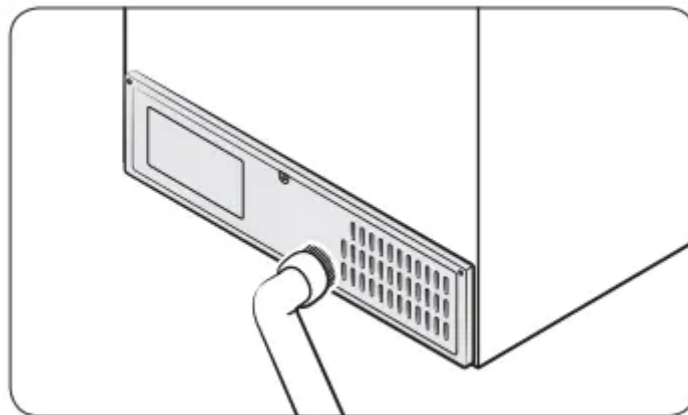

To keep cords and exposed parts of the rear panel free of dirt, vacuum the panel once or twice a year.

CAUTION Do not remove the rear panel cover. Electric shock may occur.

Replacement

Water filter

WARNING

- Do not use third-party water filters. Use only Samsung-provided or -approved filters.

- Unapproved filters may leak and damage the refrigerator, causing electric shock.
Samsung is not responsible for any damage that may occur from use of third-party water filters.

The Filter Reset indicator (**Filter**) turns red to let you know it is time to replace the water filter. Before replacing the filter, make sure the water supply line is shut off.

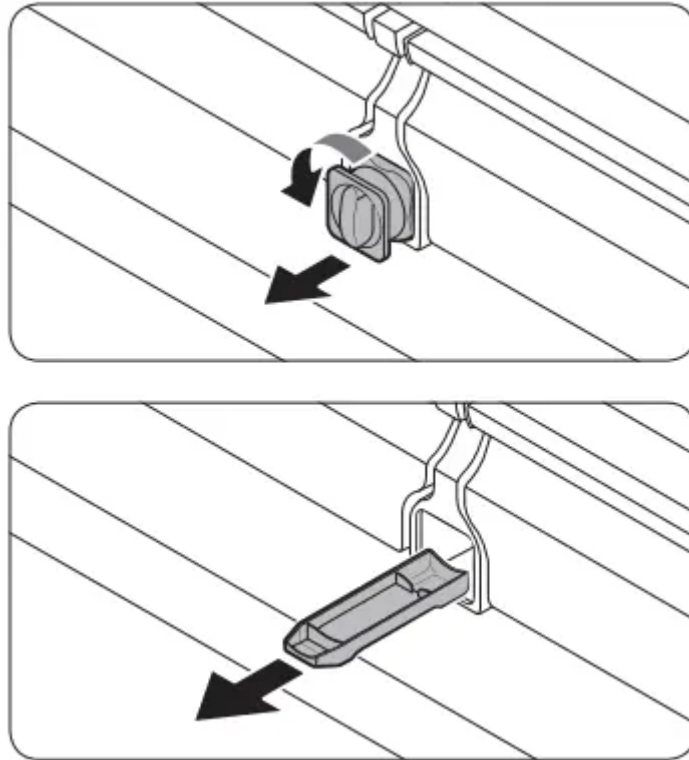

1. Shut off the water supply line.
2. Turn the knob of the filter cartridge 90 degrees counterclockwise (1/4 turn). The filter cartridge unlocks.
3. Pull out to remove the cartridge.
 - If the water filter is severely contaminated, the cartridge may not be easy to remove. If that is the case, use force to remove the cartridge.
 - To prevent water leaks from the filter opening, pull the cartridge straight out while removing it.
4. Insert a new filter cartridge. Use only Samsung-provided or approved filters.

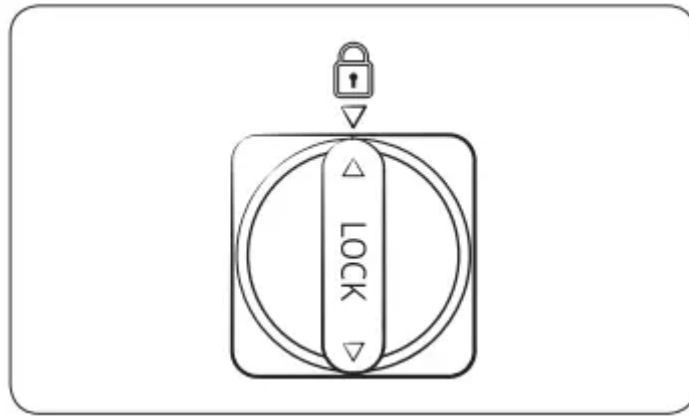

5. Turn the cartridge knob clockwise to lock into place.
6. Press and hold Ice Maker on the main panel for 3 seconds to reset the life cycle detector. The Filter Reset indicator (**Filter**) turns off.
7. When you are done replacing the filter, open the water valve and run water through the dispenser for about 7 minutes. This is to remove impurities and air from the water line.

NOTE

- A newly installed filter may cause the water dispenser to spurt water briefly. This is because air has entered the waterline.
- The replacement process may cause the water dispenser to drip for a short period of time. If it drips, simply wipe up any water on the floor with a dry towel.

Reverse osmosis water filtration system

The water pressure of the water supply system to a reverse osmosis water filtration system must be between 206 to 827 kPa.

The water pressure of the reverse osmosis water filtration system to the refrigerator's cold water line must be at least 276 kPa. If the water pressure is below these specifications:

- Check if the sediment filter in the reverse osmosis system is blocked. Replace the filter if necessary.
- Refill the water tank in the reverse osmosis system with water.
- If your refrigerator has a water filter, it may further reduce the water pressure when used in conjunction with a reverse osmosis system. Remove the water filter.

For more information or servicing, contact a licensed plumbing professional.

Ordering a new filter

To purchase a new water filter, contact a local Samsung service center or visit samsungparts.com on the web.

LED Lamps

To replace the lamps of the refrigerator, contact a local Samsung service center.

WARNING

- The lamps are not user-serviceable. Do not attempt to replace a lamp yourself. This can cause electric shock.

Troubleshooting

Before calling for service, review the checkpoints below. Any service calls regarding normal situations (No Defect Cases) will be charged to users.

General

Temperature

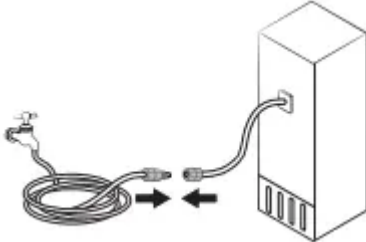
Symptom	Possible causes	Solution
Fridge/freezer does not operate. Fridge/freezer temperature is warm.	Power cord is not plugged in properly.	Properly plug in the power cord.
	Temperature control is not set correctly.	Set the temperature lower.
	Refrigerator is located near a heat source or direct sunlight.	Keep the refrigerator away from direct sunlight or a heat source.
	Not enough clearance between refrigerator and nearby walls or cabinets.	Make sure there is a gap of at least 5 cm between the refrigerator back and sides and any nearby walls or cabinets.
	Energy Saver mode is activated.	Deactivate Energy Saver mode.
	The refrigerator is overloaded. Food is blocking the refrigerator vents.	Do not overload the refrigerator. Do not allow food to block vents.
Fridge/freezer is over-cooling.	Temperature control is not set correctly.	Set the temperature higher.
Interior wall is hot.	Refrigerator has heat-proof piping in the interior wall.	<p>To prevent condensation from forming, the refrigerator has heat-proof piping in the front corners. If the ambient temperature rises, this equipment may not work effectively. This is not a system failure.</p> 

Odors

Symptom	Possible causes	Solution
Refrigerator has odors.	Spoiled food.	Clean the refrigerator and remove any spoiled food.
	Food with strong odors.	Make sure strong smelling food is wrapped airtight.

Frost

Symptom	Possible causes	Solution
Frost around the vents.	Food is blocking the vents	Make sure no food blocks the refrigerator vents
Frost on interior walls.	Door is not closed properly.	Make sure food does not block the door. Clean the door gasket.

Condensation

Symptom	Possible causes	Solution
Condensation forms on the interior walls.	If door is left open, moisture enters the refrigerator.	Remove the moisture and do not leave a door open for extended periods of time.
	Food with high moisture content.	Make sure food is wrapped airtight.

Water/ice (dispenser models only)

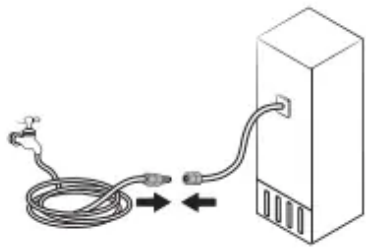
Symptom	Possible causes	Solution
Water flow is weaker than normal.	Water pressure is too low.	Make sure the water pressure is between 206 to 827 kPa.
Ice maker makes a buzzing sound.	The ice maker function is activated, but the water supply to the refrigerator has not been connected.	Press Ice Maker.
Ice maker does not make ice.	Ice maker has just been installed.	You must wait for 12 hours for the refrigerator to make ice.
	Freezer temperature is too high.	Set the freezer temperature below -18 °C or -20 °C in warm ambient air.
	Dispenser panel Lock is activated.	Deactivate dispenser panel Lock.
	Ice maker is off.	Turn on the ice maker.
Ice does not dispense.	Ice may jam if the ice dispenser is not used for a long time (approx. 3 weeks).	If you won't be using the refrigerator for a long time, empty the ice bucket and turn off the ice maker.
	Ice bucket is not properly inserted.	Make sure the ice bucket is properly inserted.
	Water line is not connected properly or water supply is not on.	Check if the water line is installed correctly. Check if the water line stop cock is closed. 
Water does not dispense.	Water line is not connected properly or water supply is not on.	Check if the water line is installed correctly. Check if the water line stop cock is closed.

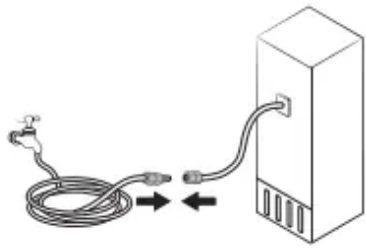
		
	Dispenser panel Lock is activated.	Deactivate dispenser panel Lock
	A third-party water filter was installed.	<ul style="list-style-type: none"> • Use only Samsung-provided or approved filters. • Unapproved filters may leak and damage the refrigerator.
	Water filter indicator turns on or blinks.	Replace the water filter. After replacing, reset the filter indicator sensor.

Do you hear abnormal sounds from the refrigerator?

Before calling for service, review the checkpoints below. Any service calls related to normal sounds will be charged to the user.

These sounds are normal.

- When starting or ending an operation, the refrigerator may make sounds similar to a car engine igniting. As the operation stabilizes, the sounds will decrease.

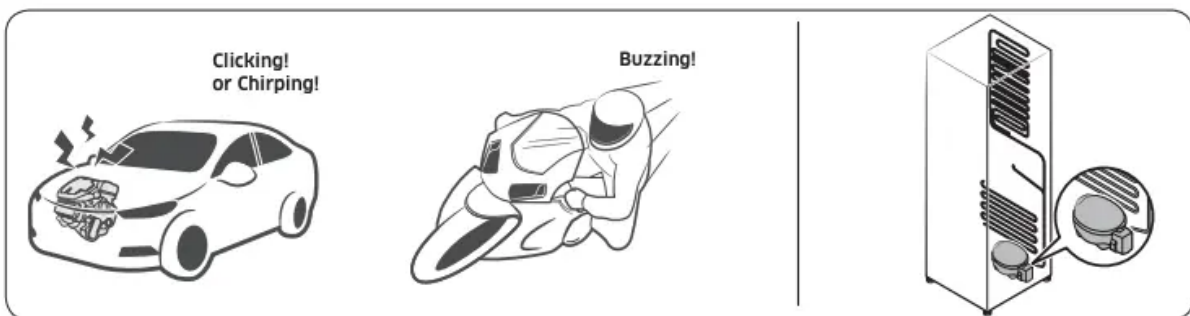

- While the fan is operating, these sounds may occur. When the refrigerator reaches the set temperature, no fan sound will occur.



- During a defrost cycle, water may drip on the defrost heater, causing sizzling sounds.



- As the refrigerator cools or freezes, refrigerant gas moves through sealed pipes, causing bubbling sounds.

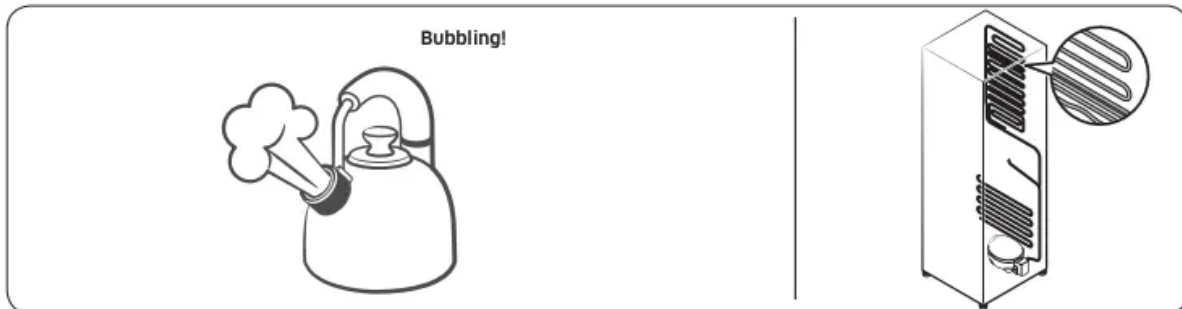

- As the refrigerator temperature increases or decreases, plastic parts contract and expand, creating knocking noises. These noises occur during the defrosting cycle or when electronic parts are working.

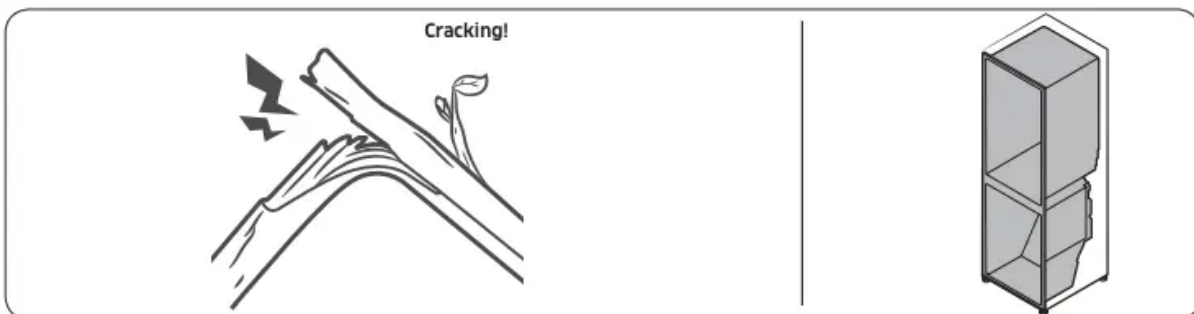

- For ice maker models: When the water valve opens to fill the ice maker, buzzing sounds may occur.

- Due to pressure equalizing when opening and closing the refrigerator door, whooshing sounds may occur.

Warning

This content is compiled from multiple sources and is provided for reference purposes only. It may not be complete or fully applicable to all situations. If you are unable to resolve your issue, please contact the product manufacturer or an authorized service provider for official support.

Document generated by [ManualsFile](#)