

## Designer Series Features

### FEATURES

1. Product Rating Plate
2. Interactive Control Panel
3. Freshness Cards
4. Door Shelves
5. Dairy Compartment
6. Glass Shelves
7. Refrigerator Drawer
8. Freezer Basket
9. Ice Container
10. Storage Drawers
11. Air Purification System
12. Water Filtration System
13. Automatic Ice Maker (ice maker models)
14. Water Dispenser (dispenser models)
15. Condenser (behind grille)

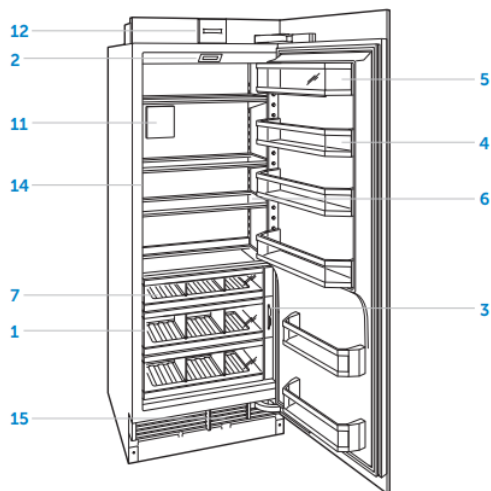

Column all refrigerator

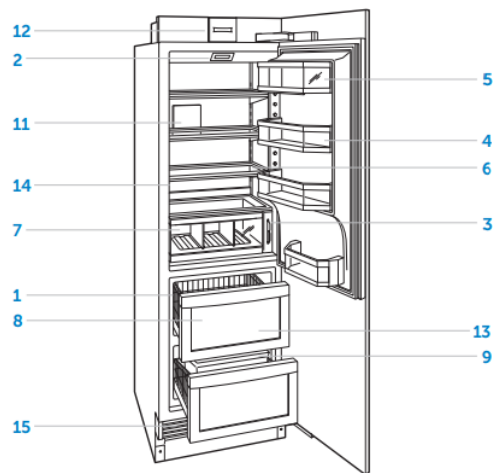

Column combination

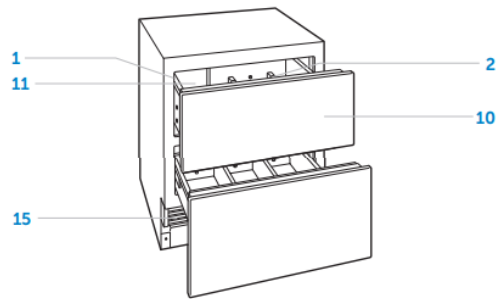

Drawer all refrigerator

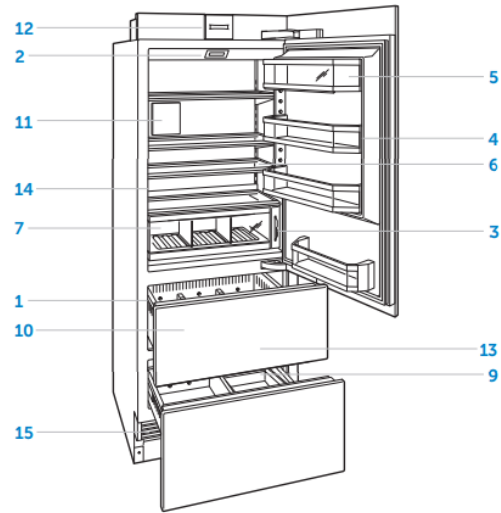

Tall combination

## Interactive Controls

### Interactive Control Panel

For initial start-up, touch and hold “power” on the control panel for 2 seconds.

Temperatures can be adjusted in one-degree increments on the home screen. Combination units have separate temperature controls for refrigerator and freezer. Temperatures are preset at 38°F (3°C) and 0°F (-18°C).

#### To adjust temperature:

1. Touch the temperature to be adjusted.
2. Touch + or – until the desired temperature is displayed. Refer to the illustration below.

Once the temperature has been adjusted, additional features can be activated or deactivated from the options screen. Touch ▶ to view the options screen. Refer to the illustration below.



Home screen

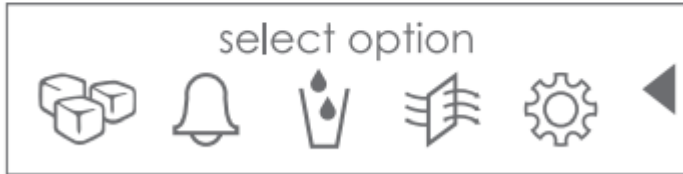

Options screen

## OPTIONS SCREEN

-  Touch to activate or deactivate the ice maker system and max ice feature.

---

-  Touch to activate or deactivate the door/drawer alarm.

---

-  Touch to activate or deactivate the water dispenser.

---











-  Touch to activate or deactivate the air purification system.

---

-  Touch to view the settings screen.

---

## SETTINGS SCREEN

|  |  |
|--|--|
|   | Touch to view model information.                         |
|   | Touch to select temperature unit, Fahrenheit or Celsius. |
|   | Touch to adjust control panel brightness and contrast.   |
|   | Touch to adjust door/drawer alarm volume and pitch.      |
|   | Touch to adjust door/drawer alarm duration.              |
|   | Touch to enter Sabbath mode.                             |
|   | Touch to view troubleshooting and service information.   |
|   | Touch to set the clock.                                  |
|   | Touch to enable or disable connect.                      |
|   | Touch to select language options.                        |
|  | Touch to adjust soft on lighting.                        |

## Storage

### Keeping Food At Its Best

#### DUAL REFRIGERATION®

This Sub-Zero features a unique Dual Refrigeration® system to keep food fresher longer.

With the Sub-Zero Dual Refrigeration® system, individual refrigerator and freezer systems have been designed to maintain accurate, consistent temperatures and proper humidity levels for longer food life expectancy. Dual Refrigeration® eliminates transfer of fresh food odors to frozen food and ice and does not freeze the moisture out of the air in the fresh food section.

For handy tips and information on how to maximize food freshness, refer to the freshness cards stored in the refrigerator.

### Refrigerator Storage

#### DOOR SHELVES

To reposition a door shelf or dairy compartment:

1. To remove, lift the shelf from the bottom and slide out. Refer to the illustration below.
2. To reinstall, place in the desired position and slide the shelf down onto the guides.

IMPORTANT NOTE: If the door opening is limited to 90°, door shelves may need to be removed before removing a storage drawer or glass shelf.

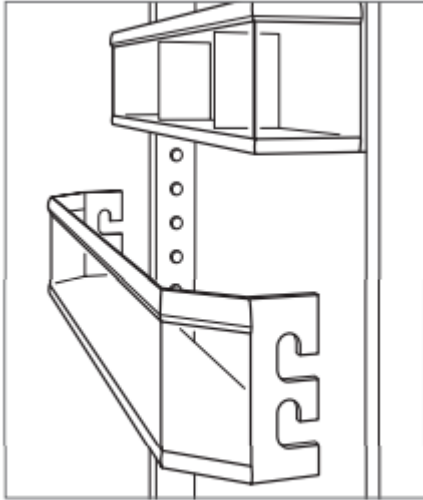

Door shelf removal

## GLASS SHELVES

To reposition a glass shelf:

1. To remove, tilt the shelf up, then lift up and out. Refer to the illustration below.
2. To reinstall, insert the shelf in the tracks along the back wall, then lower the front until it locks into position.

The stationary glass shelf at the bottom of the compartment should be placed with the beveled edge facing front. Rear support legs space the shelf away from the back wall to ensure proper air flow through the unit.

IMPORTANT NOTE: Use care when handling glass shelves to prevent breakage or scratching the interior.

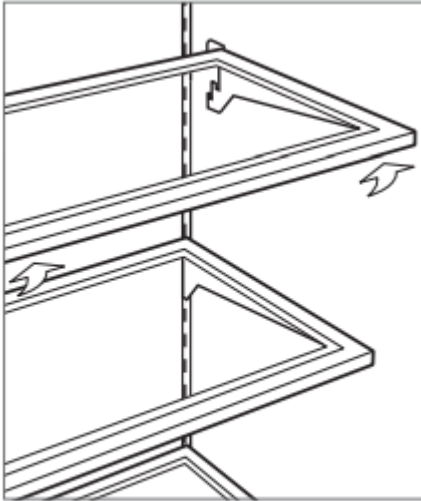

**Glass shelf removal**

## **REFRIGERATOR DRAWERS**

To remove/reinstall a refrigerator drawer:

1. To remove, pull the drawer open until it stops. Lift the front of the drawer slightly and pull straight out. Refer to the illustration below.
2. To reinstall, pull the drawer carrier out and align the bottom of the drawer with the carrier. Slide the drawer back into position.

To reposition a refrigerator drawer divider:

1. To remove, pull the divider straight up.
2. To reinstall, align tabs on the divider with notches in the drawer and push down.

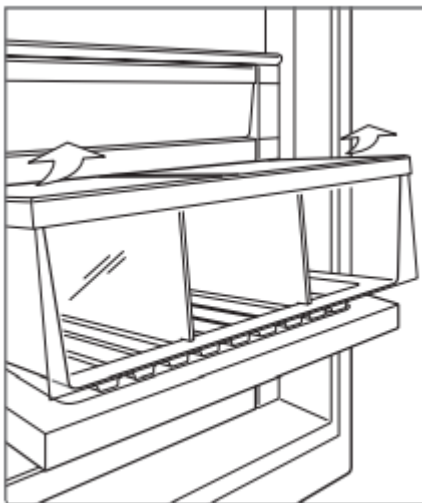

**Refrigerator drawer removal**

## Storage Drawers

### CRISPER COVER

The crisper cover in the upper storage drawer can be slid closed, left open, or removed.

To remove the crisper cover:

1. Pull the upper storage drawer all the way out.
2. Raise the front edge of the crisper cover and pull it forward and out of the drawer. Refer to the illustration below.

### DRAWER DIVIDERS

To reposition a drawer divider:

1. To remove a short divider, flex the long divider slightly, then pull upward. Refer to the illustration below.
2. For 36" wide drawer models only, one long divider is adjustable. To remove a long divider, all short dividers must be removed. Pull the long divider up until it stops, rotate counterclockwise, then pull upward.
3. To reinstall a long divider, align the grooves with the drawer tabs, rotate clockwise, then slide down.
4. To reinstall a short divider, position as desired, then slide down.

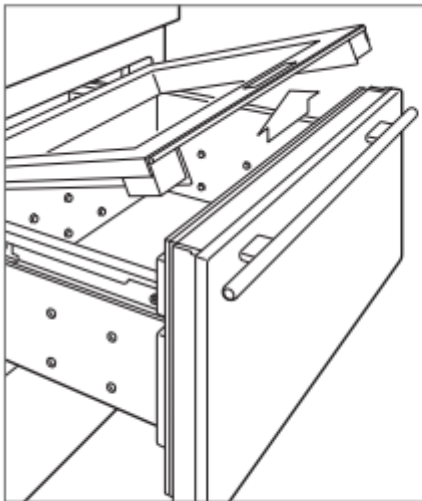

Crisper cover

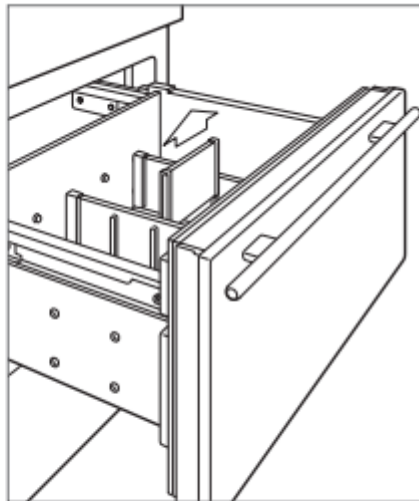

Drawer dividers

### DRAWER REMOVAL

To remove/reinstall a storage drawer:

1. To remove, pull the drawer open until it stops. Raise the front of the drawer slightly and pull straight out. Refer to the illustration below.

2. To reinstall, raise the front of drawer and place onto the slides. Align the back of the drawer with hooks on the slide, then align the white pegs at the front of the slide with holes at the front of the drawer.

**IMPORTANT NOTE:** For drawer models, the upper drawer has a control cable that must be disconnected before removing the drawer. Refer to the illustration below.

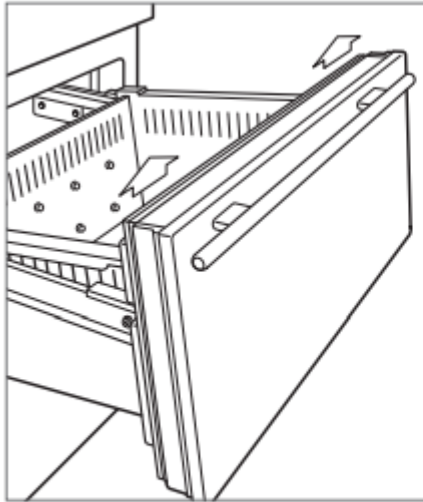

**Drawer removal**

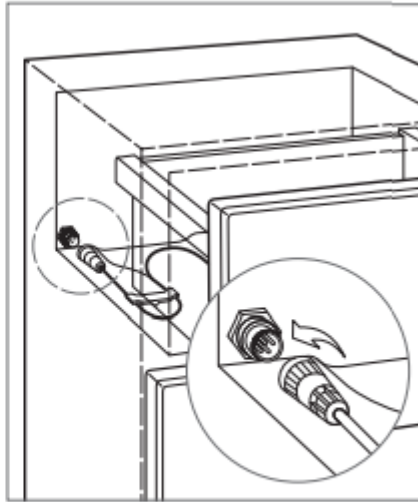

**Control cable (drawers)**

## **FREEZER BASKETS**

### **To remove a freezer basket:**

1. Pull the basket open until it stops.
2. Pull the two plastic tabs located behind the bottom two corners of the basket forward, then lift up and out. Refer to the illustrations below.

If the door opening is limited to 90°, the top basket must be removed before removing the middle or lower basket

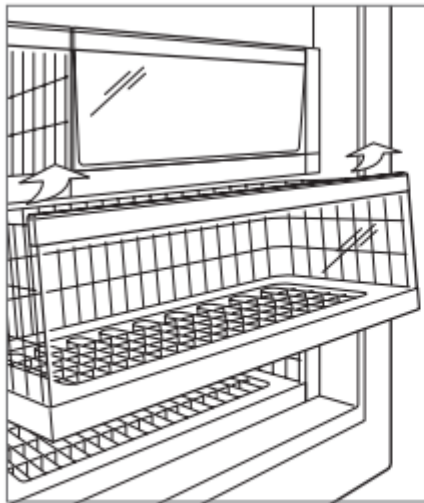

**Column freezer basket**

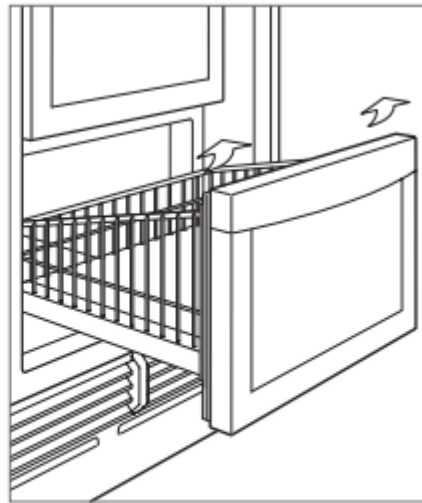

**Column combination freezer basket**

To reinstall a freezer basket (column model):

1. Push the basket slides in.
2. Align the basket with the slides and push back until it stops.
3. Press down on the front of the basket to engage the slides.

To reinstall a freezer basket (column combination model):

1. Fully extend the basket slides.
2. Align the basket with the slides and push back until the rear of the basket contacts the slide tabs.
3. Push back and down on the front of the basket to engage the tabs.

## **Freezer Storage**

### **ICE CONTAINER**

The ice maker must be turned off by touching  when the ice storage container is removed. The unit is equipped with a 3-minute delay after the ice container is removed, to ensure cubes are not ejected before the ice maker can be deactivated or the ice container is reinstalled.

To remove the ice container (column model):

1. Pull the freezer basket open until it stops.
2. Lift the container out. Refer to the illustration below.

To remove the ice container (column combination model):

1. Pull the freezer basket open until it stops.
2. Slightly angle the container to lift out. Refer to the illustration below.

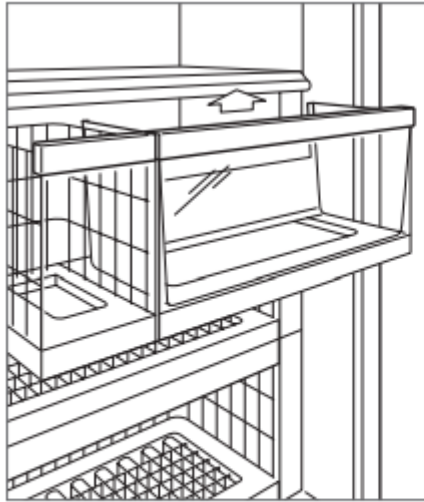

Column ice container

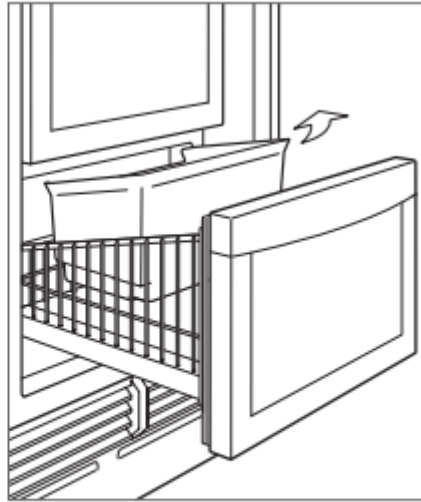

Column combination ice container

To remove the ice container (tall and drawer models):

1. Pull the freezer basket open until it stops.
2. Lift the container out. Refer to the illustration below.

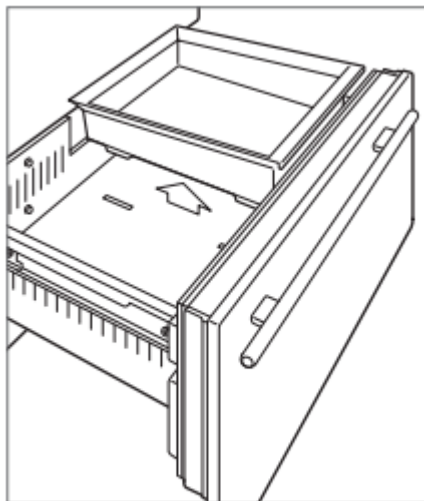

Tall and drawer ice container

## Operation

### Air Purification System

Many fresh foods emit ethylene gas, a naturally-occurring compound that hastens food ripening and spoilage. If your unit is equipped with an air purification system, the cartridge has been factory installed and is located on the back wall of the refrigerator (back of the upper drawer for drawer models).

To initiate air purification, touch  on the options screen.

#### CAUTION

The air purification system complies with applicable Federal requirements regarding incidental exposure to ultraviolet light. Lamp contains mercury. Manage in accordance with disposal laws. Visit [earth911.com](http://earth911.com) or call 800-222-7820.

#### AIR PURIFICATION CARTRIDGE

The air purification cartridge will last approximately one year. “Change Air Purifier” will appear on the control panel when the cartridge needs to be replaced. Touch “Snooze” to delay the reminder for 24 hours or until the cartridge can be replaced.

Replacement Sub-Zero air purification cartridges can be ordered online at [subzero.com/store](http://subzero.com/store). For questions, contact Sub-Zero Customer Care at 800-222-7820.

To replace the air purification cartridge:

1. To access the air purification cartridge, grasp the outside cover from the bottom and rotate upward. Refer to the illustration below.
2. Grasp the black cover from the top and rotate downward. The cartridge will pop out and can be removed.
3. Remove the new cartridge from packaging and insert with the connector pointing downward.
4. Once in position, close the black cover. Then rotate the outside cover downward.
5. Once the cartridge has been replaced, follow instructions on the control panel. The cartridge life cycle will reset for approximately one year.

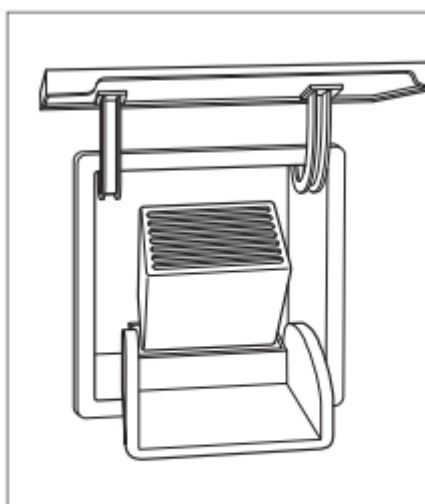

**Air purification cartridge**

#### Water Filtration System

The water filtration system supplies filtered water to the ice maker and water dispenser (dispenser models) to produce great-tasting water and ice.

**IMPORTANT NOTE:** When using the water filtration system for the first time and after filter replacement, it is necessary to clear any air from the system and allow the filter to assist in cleaning the water lines. For non-dispenser models, discard the first two full containers of ice. For dispenser models, dispense several glasses of water for a period of two minutes.

If the water filtration system will not be used, it can be placed in water filter bypass mode by removing the filter.

## **WATER FILTER**

The water filter is rated for 750 gallons (2839 L) or one year, whichever comes first. “Change Water Filter” will appear on the control panel when the filter needs to be replaced. Touch “Snooze” to delay reminder for 24 hours or until filter can be replaced.

Replacement Sub-Zero water filters can be ordered online at [subzero.com/store](http://subzero.com/store). For questions, contact Sub-Zero Customer Care at 800-222-7820.

To replace the water filter:



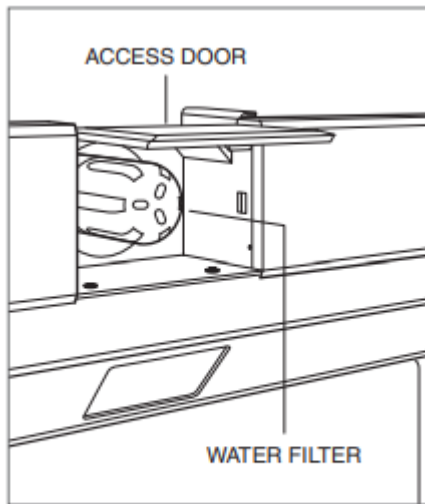

1. To access the water filter, pull out on the bottom edge of the access door and rotate upward. Refer to the illustration below.
2. To remove the old filter, rotate counterclockwise one-quarter turn, then pull out. It is normal for a small amount of water to drip when the filter is removed. It should be wiped up with a paper towel or cloth.
3. Remove the new filter from packaging and remove the plastic cap.
4. Insert the new filter into the manifold and turn clockwise.
5. Once the new filter has been installed, follow instructions on the control panel. The filter life cycle will reset for approximately one year.



**Water filter**

## **Ice Maker**

To operate the ice maker:

1.  To activate the ice maker, touch  on the options screen. A single highlighted cube indicates the ice maker is active. Three highlighted cubes indicate the max ice feature is active.
2.  To deactivate the ice maker, touch  until no cubes are highlighted.

After initial start-up, discard the first few batches of ice. The ice may contain impurities from new plumbing connections.

Max ice increases ice production up to 30% for a 24-hour period. During that period, some components may run at a higher speed resulting in a unique audible tone. This is typical and will revert back after 24 hours or when the ice container is full.

If ice is not used regularly it may fuse together. To avoid, discard the ice and allow the ice maker to replenish.

Deactivate the ice maker if the ice container is removed for an extended period. The unit is equipped with a 3-minute delay after the ice container has been removed, to ensure cubes are not ejected before the ice maker is deactivated or the ice container is reinstalled.

## **Water Dispenser**

The water dispenser is located inside the refrigerator on the left wall. Refer to the illustration below.

To dispense water:

1. Press a glass against the dispenser to activate the flow of water.
2. The flow of water will stop when the glass is pulled away.

The chilled water reservoir tank holds approximately 32 oz (1 L) of filtered water. It may take several hours to chill the water to refrigerator temperature during the original fill and after a large amount of water is dispensed.

To fill the water tank:

1. Press a glass against the dispenser until water begins to flow. A safety feature is incorporated into the dispenser to limit continuous water flow to 60 seconds.
2. If water does not dispense within 60 seconds, remove the glass, then reapply to the dispenser until water begins to flow.
3. Once the tank is full, discard the first few glasses of water. It may contain impurities from new plumbing connections.

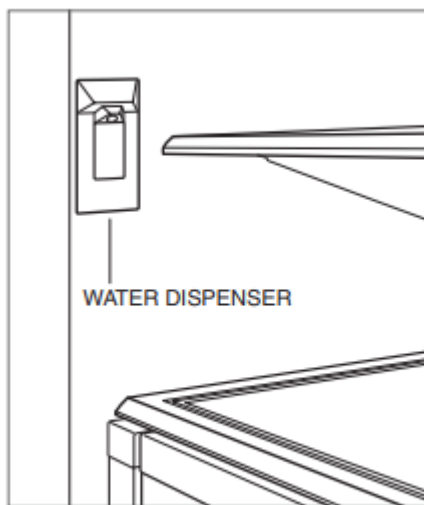

**Water dispenser**

## **Sabbath**

This appliance is certified by Star-K to meet strict religious regulations in conjunction with specific instructions found on [www.star-k.org](http://www.star-k.org).

To initiate Sabbath mode:

1. From the settings screen, touch  .
2. Follow instructions on the control panel.

## **Connect This Appliance**

Connect this appliance to remotely monitor and control it. Connecting requires a wireless router, an Internet connection with a network name and password, and a compatible mobile device. There is

no limit to the number of appliances you can connect to an account. Connect products from multiple homes to the same account. Connecting appliances is optional.

1. Download the free Sub-Zero Group Owner's App from the Apple App Store or Google Play.
2. With Bluetooth enabled on the device, stand within a few feet of the appliance, open the app, and follow the on-screen instructions.
3. Log in or create an account.
4. Tap Add An Appliance or tap + in upper right of the screen to add appliances. To identify which appliance to pair, open the appliance door.
5. Tap + next to the appliance to select it. If identical appliances appear, an additional step identifies which appliance to pair.
6. Tap Pair Via Bluetooth. Wait for setup to complete, then tap Set Up Your Appliance For Pairing.
7. Tap Choose a Network on the Connect Your Appliance to Wi-Fi screen.
8. Select the home Wi-Fi network and enter the network password.
9. Tap Turn on Notifications to allow notifications about the appliance (for example, door left ajar).
10. Tap Done on the Success screen to complete the setup.

## Care Recommendations

### Cleaning

#### STAINLESS STEEL EXTERIOR

Use a nonabrasive stainless steel cleaner and apply with a soft lint-free cloth. To bring out the natural luster, lightly wipe the surface with a water-dampened microfiber cloth followed by a dry polishing chamois. Always follow the grain of stainless steel.

#### INTERIOR CLEANING

To clean interior surfaces and all removable parts, wash with a mild solution of soap, water, and baking soda. Rinse and dry thoroughly. Avoid getting water on the lights and control panel.

#### VACATIONS

For extended vacations, turn power off at the control panel. Empty the unit and block doors open slightly to let fresh air in and keep the interior dry. The water filter should be replaced before start-up.

#### CONDENSER CLEANING

The condenser is located behind the kickplate. Clean the condenser every 6–12 months.

To clean the condenser:

1. Turn power off at the control panel.
2. Remove the kickplate by extracting the two mounting screws. Refer to the illustration below.
3. Use a soft bristle brush and vacuum to remove dust and lint from the condenser. To avoid damaging condenser fins, vacuum in the direction of the fins

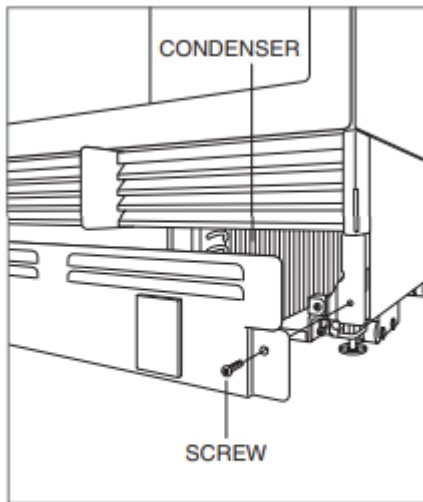

Condenser location

## Troubleshooting

### UNIT OPERATION

#### No lights or cooling.

- Verify power is on.
- Verify electrical power to the unit and home circuit breaker is on.

#### No lights in the refrigerator or freezer.

- The door/drawer may have been left ajar, which has disabled lights to eliminate excess heat. If the lights are out, close the door/drawer for one hour. If the lights are still out, contact Sub-Zero Factory Certified Service.
- LED interior lighting must be replaced by Sub-Zero Factory Certified Service.

#### Frost, condensation, or ice buildup inside the unit.

- Verify the condenser is clean.
- Verify the door/drawer is closing properly.
- Verify the door/drawer has not been left ajar.

- Verify the door/drawer gasket does not have rips or tears. If it does, contact Sub-Zero Factory Certified Service.
- If icing is heavy, turn the unit off and use a hair dryer to melt the ice. The hair dryer should be set on low and kept moving at all times. Once the ice has melted, wipe up any water with a cloth or paper towel.

**High temperatures, the unit runs excessively or the unit is giving off too much heat.**

- Verify the condenser is clean.
- Verify the door/drawer is closing properly.
- Verify the door/drawer has not been left ajar.
- Increased ambient temperatures may cause the compressors to run longer.
- If the temperature display shows 38° and 0°, but is not cooling, the unit may be in showroom mode. Contact Sub-Zero Customer Care at 800-222-7820.

**No water from the dispenser.**

- Wait one hour, then try the dispenser again. Contact Sub-Zero Customer Care at 800-222-7820 if unresolved.

**ODOR**

- The unit should be cleaned before using for the first time. This will clear any odors that may have been trapped during shipping.
- Replace the air purification cartridge.
- Clean the unit and shelving thoroughly.
- Uncovered food could create an odor, which may require cleaning.

**ICE PRODUCTION**

**No ice.**

- Verify the ice cube indicator appears in the control panel display.
- Verify the ice maker has been on for at least 24 hours.
- Verify the freezer temperature is near 0°F.
- Verify the ice container is properly installed.
- Verify the ice maker arm in the down position.
- Verify water is being supplied to the unit.
- Verify the water filter has been replaced within the last 12 months and installed properly.
- Verify the water filter has been removed if a reverse osmosis filtration system is being used.



**Blue or green ice.**

- Possible copper supply line corrosion. Contact a plumber to clean or replace.

**Black flecks in the cubes.**

- Stop use and contact Sub-Zero Factory Certified Service.

**Bad taste.**

- Defrost the freezer and clean with soap and water.
- Place coffee grounds or charcoal briquettes in the freezer to absorb odor.

**Hollow cubes.**

- Clean the condenser. Contact Sub-Zero Factory Certified Service if unresolved.

**SERVICE**

- Maintain the quality built into your product by contacting Sub-Zero Factory Certified Service. For the name of the nearest Sub-Zero Factory Certified Service, check the Product Support section of our website, [subzero.com](http://subzero.com) or call Sub-Zero Customer Care at 800-222-7820.
- When contacting service, you will need the model and serial number of your unit. Both numbers are listed on the product rating plate. Refer to page 7 for rating plate location.
- For warranty purposes, you will also need the date of installation and name of your authorized Sub-Zero dealer. This information should be recorded on page 3.

**Warning**

This content is compiled from multiple sources and is provided for reference purposes only. It may not be complete or fully applicable to all situations. If you are unable to resolve your issue, please contact the product manufacturer or an authorized service provider for official support.