

CLASSIC REFRIGERATION

Features and specifications are subject to change at any time without notice. Visit subzero.com/specs for the most up-to-date information.

Important Note: To ensure this product is installed and operated as safely and efficiently as possible, take note of the following types of highlighted information throughout this guide:

IMPORTANT NOTE: highlights information that is especially important.

CAUTION: indicates a situation where minor injury or product damage may occur if instructions are not followed.

WARNING: states a hazard that may cause serious injury or death if precautions are not followed.

IMPORTANT NOTE: Throughout this guide, dimensions in parentheses are millimeters unless otherwise specified.

IMPORTANT NOTE: Save these instructions for the local electrical inspector.

Product Information

Important product information, including the model and serial number, are listed on the product rating plate. The rating plate is located at the top frame of the unit, inside the door. Refer to the illustration below.

If service is necessary, contact Sub-Zero Factory Certified Service with the model and serial number. For the name of the nearest Sub-Zero Factory Certified Service or for questions regarding the installation, visit the Support and Service section of our website, subzero.com, or call Sub-Zero Customer Care at 800-222-7820.

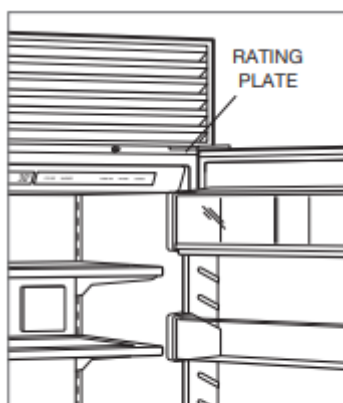

Rating plate location

Tools and Materials

- Screwdrivers—standard and Phillips.

- Power drill.
- Drill bits (masonry bits required for concrete installation).
- Torx drives—T-10, 15, and 20.
- Standard Allen wrench set.
- Standard socket and wrench set.
- 2' and 4' levels.
- Tubing cutter.
- 3' of 1/4" OD copper, braided stainless steel, or PEX tubing.
- Saddle valve.
- Material to protect home, flooring, and cabinetry during installation.

Opening Dimensions

STANDARD INSTALLATION

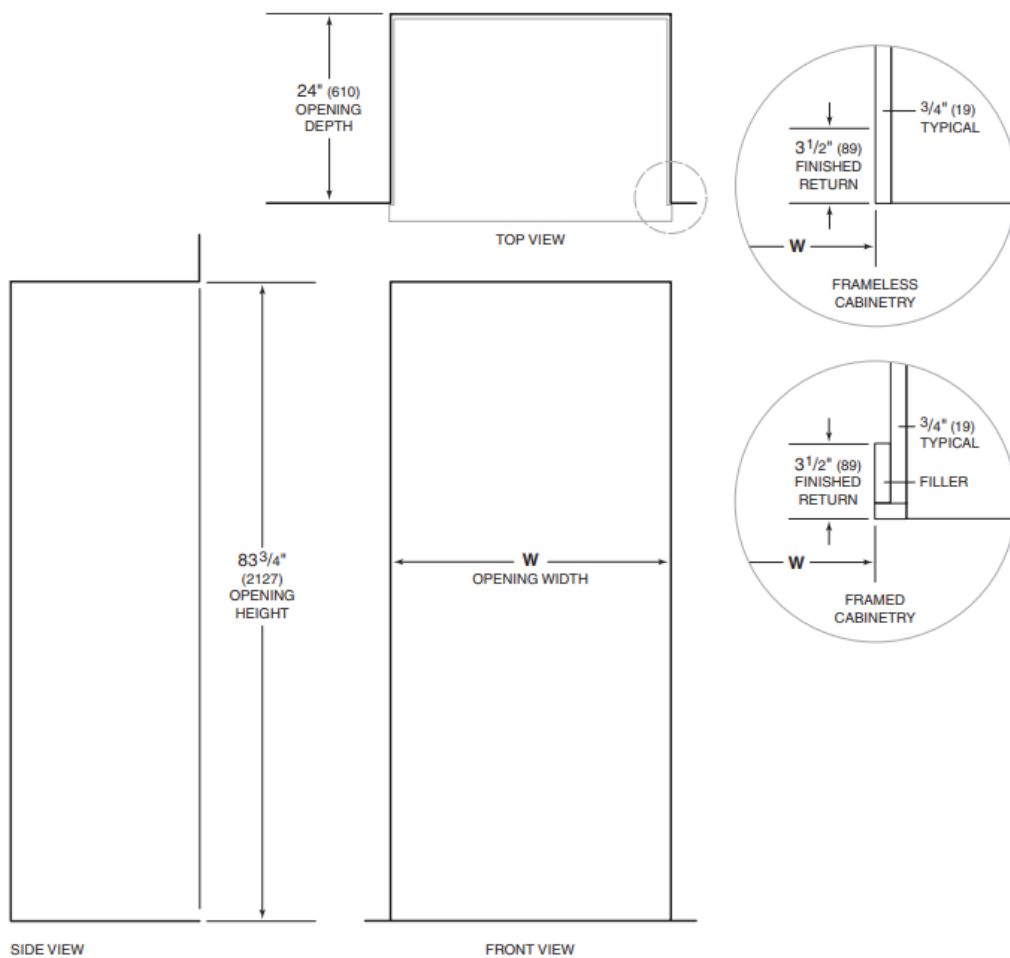

NOTE: 3 1/2" (89) finished returns will be visible and should be finished to match cabinetry. Shaded line represents profile of unit.

OPENING WIDTH	W
30" Model	29 1/2" (749)
36" Model	35 1/2" (902)
42" Model	41 1/2" (1054)
48" Model	47 1/2" (1206)

If two units are installed side by side, refer to page 6.

FLUSH INSET INSTALLATION

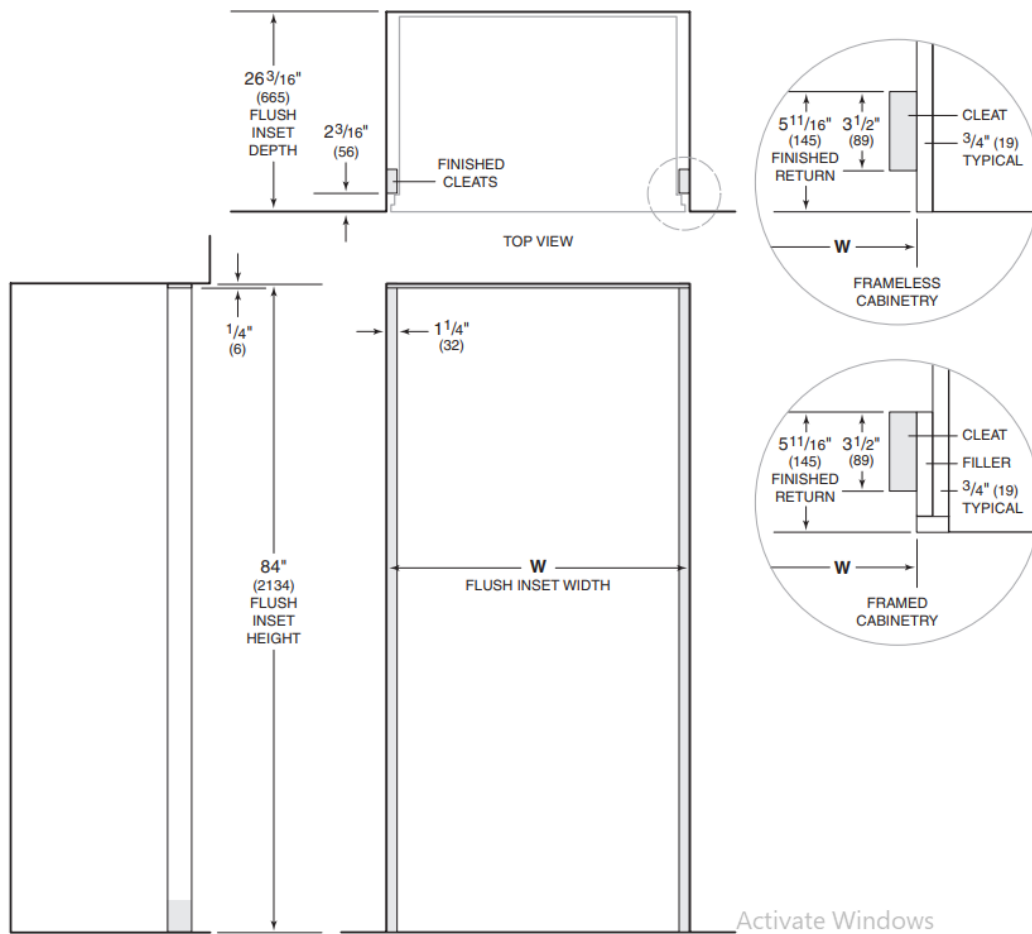

NOTE: $3\frac{1}{2}$ " (89) finished returns and shaded areas will be visible and should be finished to match cabinetry. Shaded line represents profile of unit with $\frac{3}{4}$ " (19) panel.

FLUSH INSET WIDTH	W
30" Model	32" (813)
36" Model	38" (965)
42" Model	44" (1118)
48" Model	50" (1270)

Dimensions assume a 3/4" (19) panel thickness. If two units are installed side by side, refer to page 7.

DUAL STANDARD INSTALLATION

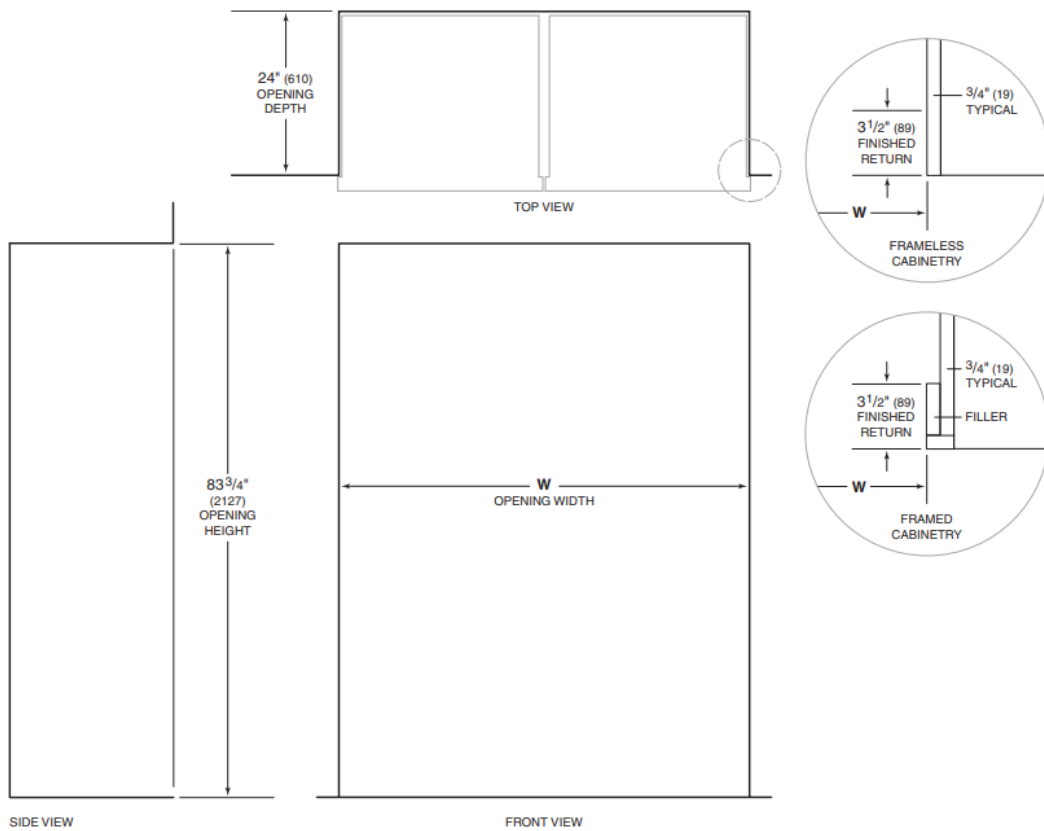

NOTE: 3 1/2" (89) finished returns will be visible and should be finished to match cabinetry. Shaded line represents profile of unit.

DUAL OPENING WIDTH	W
Two 30" Models	59 3/4" (1518)
30" and 36" Models	65 3/4" (1670)
Two 36" Models	71 3/4" (1822)

A dual installation kit is required for this installation

DUAL FLUSH INSET INSTALLATION

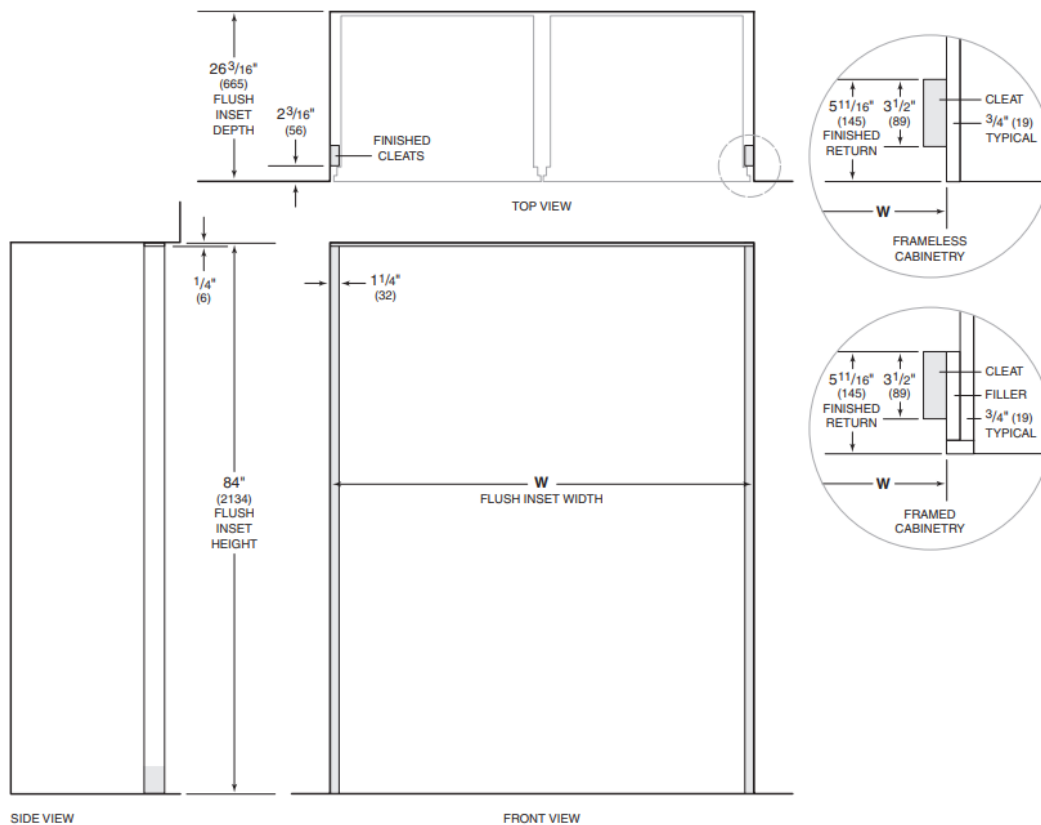

NOTE: $3 \frac{1}{2}''$ (89) finished returns and shaded areas will be visible and should be finished to match cabinetry. Shaded line represents profile of unit with $\frac{3}{4}''$ (19) panel.

DUAL FLUSH INSET WIDTH	W
Two 30" Models	62 1/4" (1581)
30" and 36" Models	68 1/4" (1734)
Two 36" Models	74 1/4" (1886)

Dimensions assume a 3/4" (19) panel thickness. A dual installation kit is required for this installation.

Dual Installation

If two units are installed side by side, a dual installation kit may be required. Installations without a custom filler strip require a dual installation kit. If a dual installation kit is not specified, a 2" (51) filler strip is recommended between units. Dual installations without a filler strip can only be accomplished using two units with opposite hinges. Refer to the illustrations below.

Dual installation kits are available through an authorized Sub-Zero dealer. For local dealer information, visit the find a showroom section of our website, subzero.com. For questions regarding the installation, call Sub-Zero Customer Care at 800-222-7820.

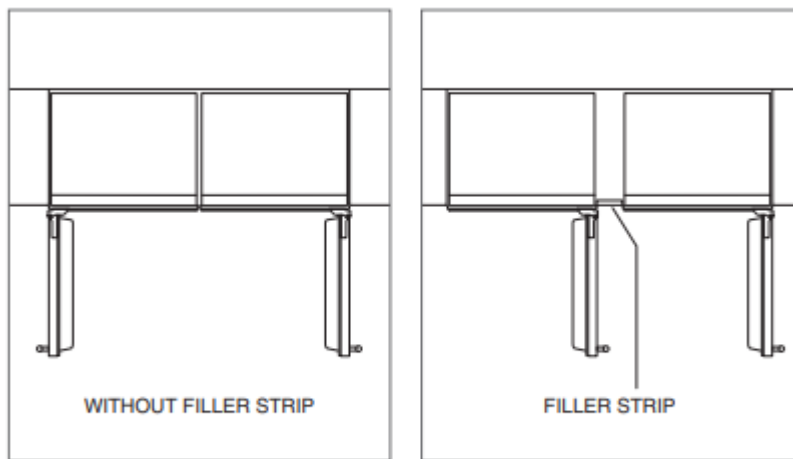

Opposite hinges

Same side hinges

Electrical Requirements

Installation must comply with all applicable electrical codes.

The electrical supply should be located within the shaded area shown in the illustration below. A separate circuit servicing only this appliance is required. A ground fault circuit interrupter (GFCI) is not recommended and may cause interruption of operation.

ELECTRICAL REQUIREMENTS	
Electrical Supply	115 VAC, 60 Hz
Service	15 amp dedicated circuit
Receptacle	3-prong grounding-type

CAUTION: The outlet must be checked by a qualified electrician to be sure it is wired with the correct polarity. Verify the outlet is properly grounded.

WARNING: Do not use an extension cord, two-prong adapter, or remove the power cord ground prong.

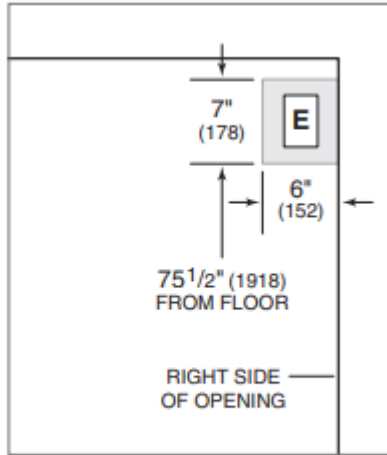

Electrical supply location

Plumbing Requirements

Installation must comply with all applicable plumbing codes.

The water supply line should be located within the shaded area shown in the illustration below. The water supply line should be connected to the house supply with an easily accessible shut-off valve. Do not use self-piercing valves. The water supply line must not interfere with the installation of the anti-tip brackets.

A reverse osmosis system can be used provided there is constant water pressure of 35–120 psi (2.4–8.3 bar) supplied to the unit at all times. In this application, the water filtration system must be bypassed by removing the filter. A copper line is not recommended for this application.

PLUMBING REQUIREMENTS	
Water Supply	1/4" OD copper, braided stainless steel, or PEX tubing
Pressure	35–120 psi (2.4–8.3 bar)
Excess Line for Connection	36" (914)

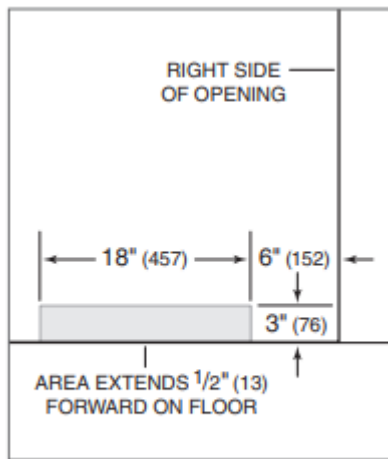

Water supply location

Preparation

Uncrate the unit and inspect for damage. Remove the wood base and discard the shipping bolts and brackets. Remove and recycle packing materials. Do not discard the kickplate, anti-tip brackets, and hardware.

Completely retract the front leveling legs to allow the unit to be moved into position. The front and rear leveling legs can be adjusted from the front once the unit is in position.

Remove the drain pan from the base of the unit to avoid damage and to allow for proper placement of the appliance dolly.

The grille assembly should be removed prior to moving the unit. To remove, pull out on the bottom edge of the grille and rotate upward. Loosen the back two grille mounting screws and remove the front two grille mounting screws. Refer to the illustrations below. With the grille held firmly, pull forward to remove.

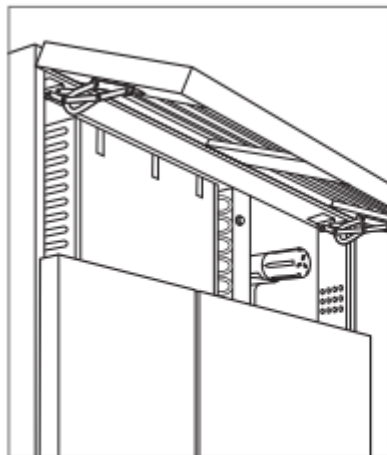

Grille removal

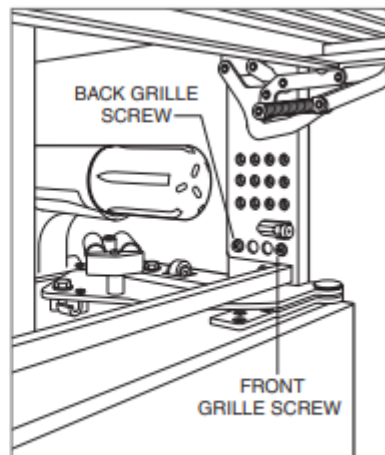

Grille mounting screws

Anti-Tip Bracket

WARNING: To prevent the unit from tipping forward, the anti-tip brackets must be installed

The two anti-tip brackets must be installed exactly 24" (610) from the front of the opening to the back of the brackets and a minimum of 4" (102) from the sides of the opening. This depth will increase to 263/16" (665) for a flush inset installation based on 3/4" (19) thick panels. Failure to properly position the anti-tip brackets will prevent proper engagement.

Use all anti-tip bracket hardware as instructed for wood or concrete floors.

IMPORTANT NOTE: For wood or concrete floor applications, if the #12 screws do not hit a wall stud or wall plate, use the #8 screws and #12 washers with the wall anchors.

IMPORTANT NOTE: In some installations the subflooring or finished floor may necessitate angling the screws used to fasten the anti-tip brackets to the back wall.

ANTI-TIP HARDWARE	
2	Anti-tip brackets
12	#12 x 2 1/2" pan head screws
4	3/8"-16 x 3 3/4" wedge anchors
12	#12 flat washers
4	#8-18 x 1 1/4" truss head screws
4	Nylon Zip-it® wall anchors

WOOD FLOOR APPLICATION

After properly locating the anti-tip brackets in the opening, drill pilot holes 3/16" (5) diameter maximum in the wall studs or wall plate. Use the #12 screws and washers to secure the brackets. Verify the screws penetrate through the flooring material and into the wall studs or wall plate a minimum of 3/4" (19). Refer to the illustration below.

CONCRETE FLOOR APPLICATION

After properly locating the anti-tip brackets in the opening, drill pilot holes 3/16" (5) diameter maximum in the wall studs or wall plate. Drill 3/8" (10) diameter holes into the concrete a minimum of 1 1/2" (38) deep. Use the #12 screws and washers to secure the brackets to the wall, and use the 3/8" wedge anchors to secure the brackets to the floor. Verify the screws penetrate the wall studs or wall plate a minimum of 3/4" (19). Refer to the illustration below.

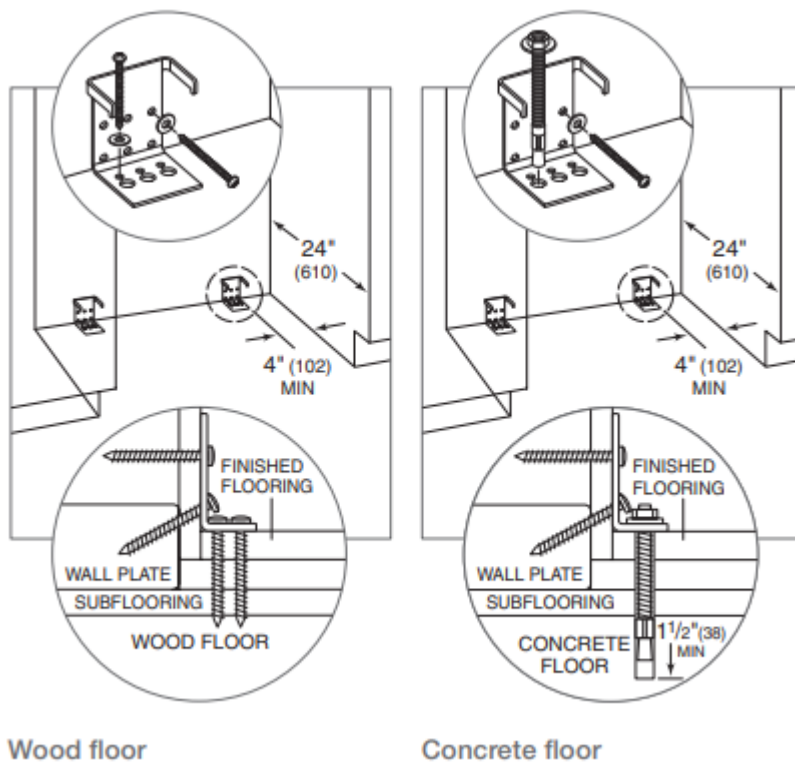

CONCRETE WEDGE ANCHOR INSTALLATION

1. Drill a 3/8" (10) diameter hole any depth exceeding the minimum embedment. Clean the hole or drill additional depth to accommodate the drill fines.
2. Assemble the washer and nut flush with the end of anchor to protect threads. Drive the anchor through the material to be fastened until the washer is flush with the surface material.
3. Expand the anchor by tightening the nut 3–5 turns past hand-tight position or to 25 foot-pounds of torque.

WARNING: Verify there are no electrical wires or plumbing in the area which the screws could penetrate.

CAUTION

Always wear safety glasses and use other necessary protective devices or apparel when installing or working with anchors.

Anchors are not recommended for use in lightweight masonry material such as block or brick, or for use in new concrete which has not had sufficient time to cure. The use of core drills is not recommended to drill holes for the anchors.

Placement

CAUTION: Before moving the unit into position, secure door(s) closed and protect any finished flooring.

Use an appliance dolly to move the unit near the opening.

If the unit has been on its back or side, it must stand upright for a minimum of 24 hours before connecting power.

Plug the power cord into the grounded outlet and roll the unit into position. Verify the anti-tip brackets are properly engaged.

IMPORTANT NOTE: If used, the side panels must be installed before the unit is placed in its final position. Refer to page 15.

Water Line

Approximately 3' (.9 m) of 1/4" plastic tubing is connected to the unit with a preassembled 1/4" compression connection under the unit. The water line fitting connection kit, provided with the unit, contains a 1/4" compression union fitting for connection to the household water line.

Purge the water line prior to final connection to the unit. This will remove any debris that may be present in the tubing from installing the new water line.

Place the sleeve and nut on the water line and fasten to the connection at the end of the tubing. Do not over tighten. Check all water line fittings for leaks. Verify the drain pan can be installed and removed without interference with the water line.

IMPORTANT NOTE: If a reverse osmosis system is used, it is recommended the water filtration system be bypassed by removing the filter.

IMPORTANT NOTE: Water lines cannot be exposed to freezing temperatures.

Custom Panels

For overlay and flush inset applications, custom door and grille panels must be installed. The panel size is critical for a proper fit. To verify panel requirements and dimensions, refer to the Sub-Zero Design Guide at subzero.com/specs.

IMPORTANT NOTE: Flush inset applications require a minimum 1/2" (13) reveal on all sides.

Finish all sides of the custom panels. They may be visible when the door is open or through the window of glass door models.

EXTERNAL DISPENSER

For external dispenser models, the dispenser bezel must be removed before the custom panels can be installed.

The bezel will accommodate a 1/4" (6) thick panel for framed applications and a 3/4" (19) thick panel for overlay and flush inset applications. Panels thicker than 3/4" (19) must be routed in the dispenser area to 1 1/8" (29) (including the backer and spacer panels).

To Remove the Bezel:

1. Lift, rotate, and remove the tray.
2. Lift and remove the grille.
3. Remove the screw from the center of the chute and remove the chute.
4. Rotate the control panel downward and disconnect the wire harness.
5. Remove the screws from each corner of the bezel and pull the bezel forward.

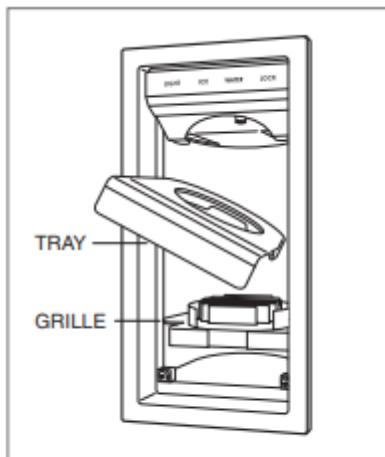

Tray and grille removal

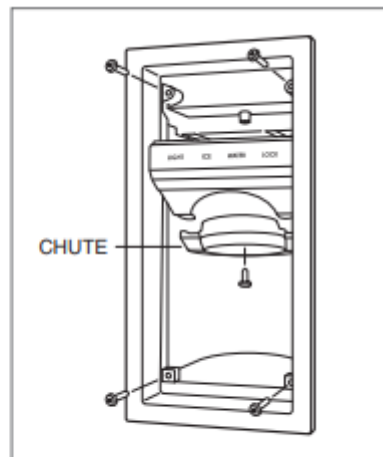

Dispenser bezel removal

DOOR PANELS

To install custom door panels, remove the handle side trim molding. Insert a screwdriver tip into the top corner slot on the handle side and pop out the trim. For the drawer, insert a screwdriver tip into the slot on either side of the trim running along the top of the drawer and pop out the trim. Remove the screws and frame. Refer to the illustrations below.

The door has a 1/4" (6) frame for the custom panel to slide into. If the panel is thicker than 1/4" (6), rout an edge around the panel or mount the panel on a sheet of 1/4" (6) thick material, then insert into the frame.

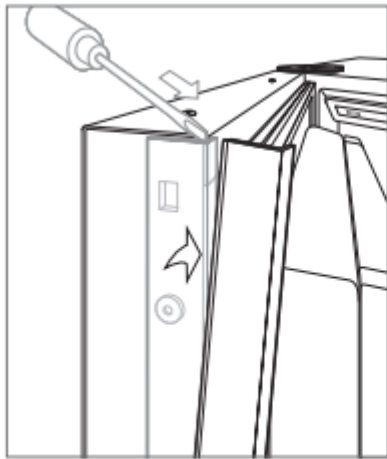

Door side trim

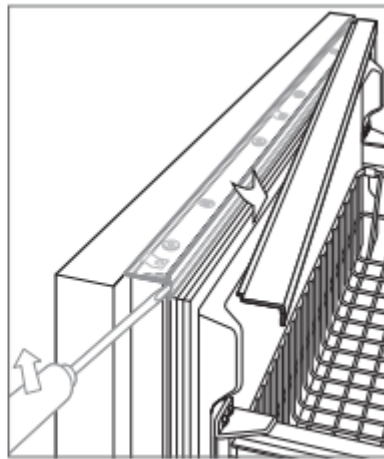

Drawer top trim

A .10" (3) space is required between the backer panel and the custom panel to allow the panel to slide into the door frame. Refer to the illustrations below for critical dimensions.

Install handle hardware before inserting the panel. Large D-style handles are recommended rather than knobs. Screw heads must be countersunk into the panel.

Slide the panel into the frame.

To reinstall the door trim molding, insert the top of the trim into grooves at the top of the door and work downward, snapping the trim into clips on the door frame. For the drawer, start at one end and move towards the opposite end, snapping the trim into the clips.

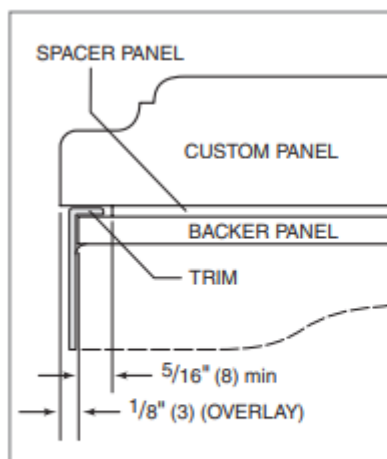

Panel assembly cross section
(overlay)

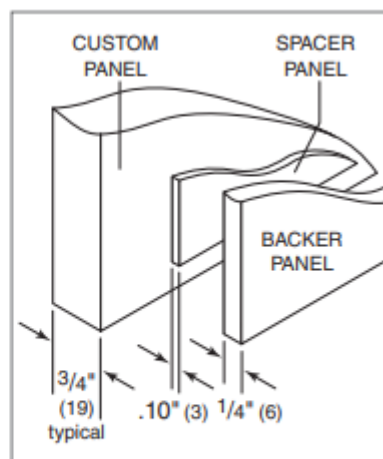

Panel assembly rear view

GRILLE PANEL

Remove the bottom grille frame by extracting the two lower corner screws from each side of the grille assembly. Refer to the illustration below.

With the bottom section removed, slide the custom grille panel into the frame. If the panel is thinner than 1/4" (6), a filler material will need to be installed to achieve a proper fit. Once the

panel is installed, reattach the bottom grille frame by sliding the corner brackets back into position, then reinstall the four corner screws.

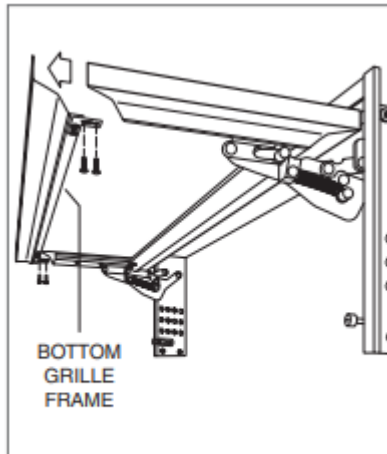

Grille frame assembly

SIDE PANEL

When installing a custom side panel, an accessory kit is required and is available through an authorized Sub-Zero dealer. For local dealer information, visit the find a showroom section of our website, subzero.com. Stainless steel and white enamel side panels are also available from an authorized Sub-Zero dealer.

IMPORTANT NOTE: The use of side panels may change the width of the opening.

A custom side panel must be a minimum of 24" (610) deep and 1/2" (13) thick. Routing will be necessary for the side panel to fit flush against the side of the unit. Refer to the illustrations below.

IMPORTANT NOTE: The height of the side panel will vary with the height of the grille. Verify the finished height before modifying the panels.

IMPORTANT NOTE: For over-and-under and French door models, additional routing will be necessary to accommodate the lower hinge plate of the refrigerator.

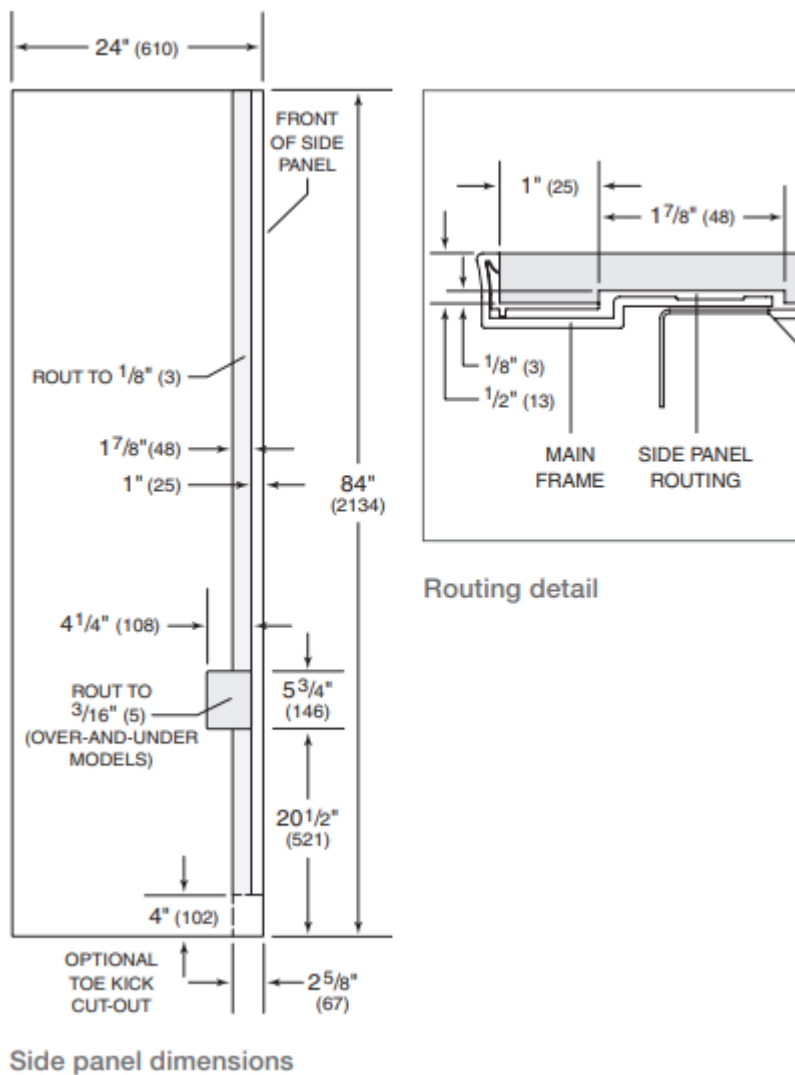

Alignment

LEVELING

Once the unit is in position, turn the front leveling legs clockwise to adjust the height. The rear height adjustment can be made from the front of the roller base. Using a 3/8" socket, turn the 3/8" hex bolt clockwise to raise the unit or counterclockwise to lower. Use the lowest torque setting when using a power drill. Do not turn the rear leveling legs by hand. Refer to the illustration below.

When the unit is properly leveled, door and drawer adjustments are less likely to be necessary.

IMPORTANT NOTE: Level the unit to the floor, not the surrounding cabinetry. This could affect the operation of the unit, such as door closing.

WARNING: To reduce the possibility of the unit tipping forward, the front leveling legs must be in contact with the floor.

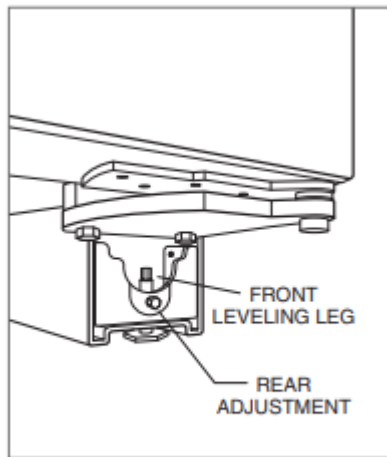

Rear roller base adjustment

DOOR ADJUSTMENT

The doors of side-by-side and over-and-under models can be adjusted in and out, and side to side tilt. The doors of side-by-side models can also be adjusted up and down.

To make adjustments, slightly loosening the two upper hinge bolts on the upper hinge plate using a 1/2" wrench. Refer to the illustration below.

In-and-Out Adjustment: For a left-hinge door, using a 5/32" allen wrench, turn the adjustment bolt clockwise to bring the handle side of the door inward, and counterclockwise to move the handle side outward. Reverse directions for a right-hinge door.

Side-to-Side Tilt Adjustment: For a left-hinge door, using a 3/8" wrench, turn the adjustment bolt clockwise to raise the handle side of the door, and counterclockwise to lower the handle side. Reverse directions for a right-hinge door.

Up-and-Down Adjustment: For a left-hinge door, using a 1/4" allen wrench, turn the adjustment bolt clockwise to raise the door and counterclockwise to lower. Refer to the illustration below. Reverse directions for a right-hinge door.

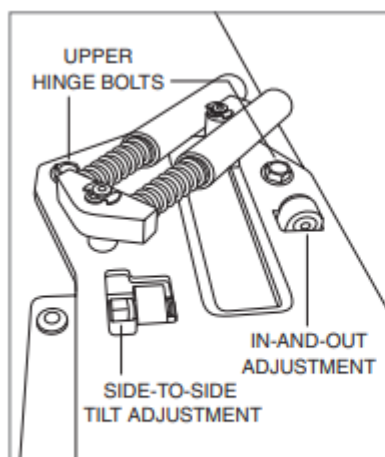

Door adjustment bolts

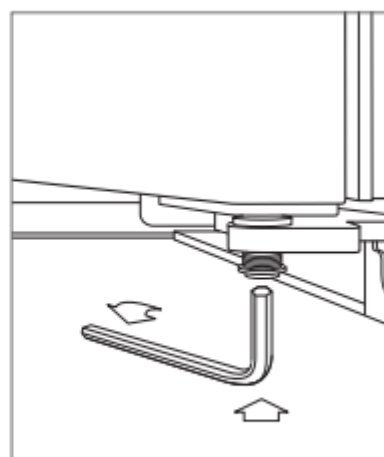

Up-and-down door adjustment

Completion

GRILLE INSTALLATION

Install the grille assembly and check for proper fit. The grille is designed to rest on the upper door hinge(s) to minimize the reveal between the top of the door and bottom of the grille. To eliminate interference, the grille height can be adjusted. Loosen the four grille adjustment screws (two on each side) and adjust the grille height as needed. Refer to the illustration below.

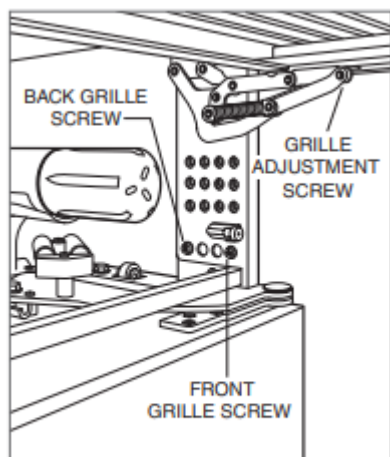

Grille height adjustment

ANCHORING

After the unit has been leveled and door adjustment completed, anchor the unit to the opening to ensure a proper fit and secure installation.

To anchor the top of the unit, open the grille and install the screws provided through the grille frame into cabinetry. There are several hole locations. Refer to the illustration below. Check for proper door clearance by opening the door.

To anchor the bottom of the unit, drive a screw through the side hole inside each roller base assembly. The screw will need to go in at an angle to attach properly. Refer to the illustration below. Additional material may be needed behind the cleat to ensure sufficient anchoring.

CAUTION: If the screws provided are not suitable for the installation, use adequate screws.

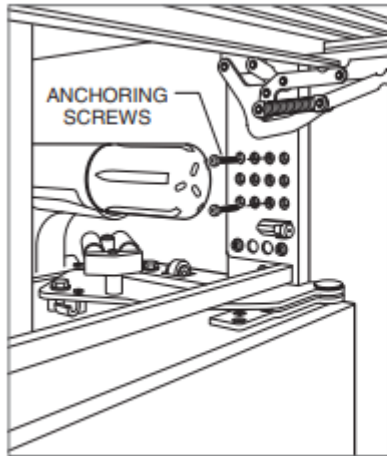

Top anchoring

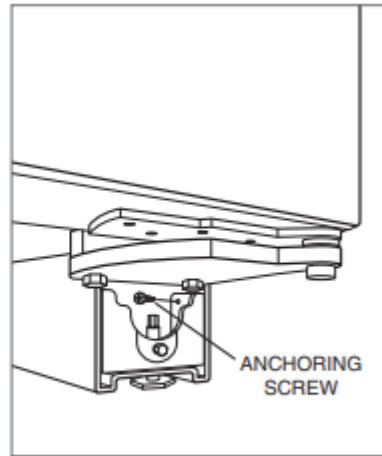

Bottom anchoring

Reinstall the drain pan and verify it is in the proper position.

Install the kickplate using the screws to attach it to the brackets on the inside of each roller base. Refer to the illustration below. The kickplate must be removable for service. The floor cannot interfere with removal. Refer to the label mounted on the kickplate support for height clearance.

Turn power on by touching POWER on the control panel.

Install the light diffuser by aligning the slots of the light diffuser onto the bracket pegs and pulling forward so the tabs on the slots engage the bracket pegs. Refer to the illustration below.

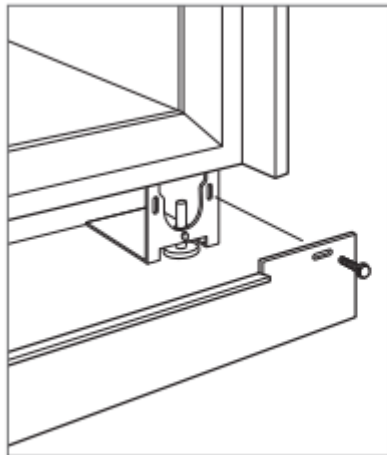

Kickplate installation

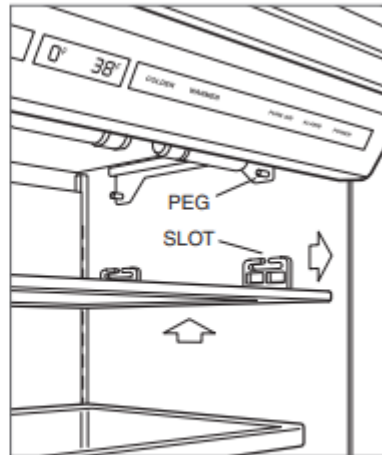

Light diffuser installation

WATER FILTER BYPASS

If the water filtration system will not be used, it can be placed in water filter bypass mode by removing the water filter. Refer to the illustration below. Follow these steps to remove the water filter:

1. Pull out on the bottom edge of the grille assembly and tilt the grille frame upward.
2. To remove the cartridge, rotate the cartridge counterclockwise one-quarter turn and pull out. Refer to the illustration below.

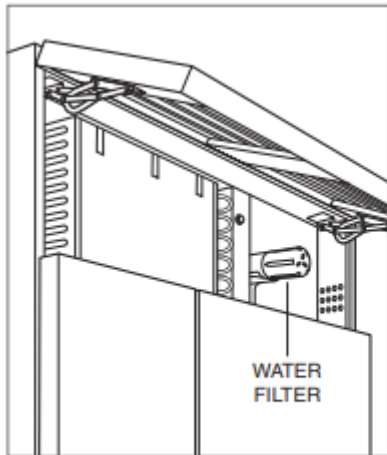

Location of water filter

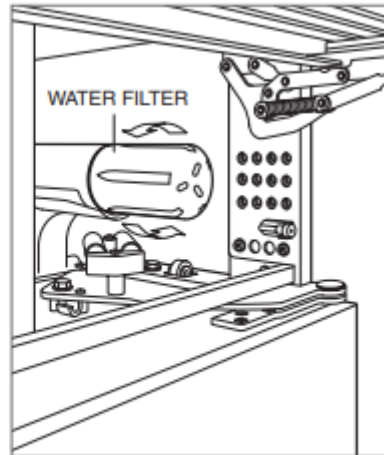

Water filter removal

90° DOOR STOP

The doors of all models open to 110°. A 90° door stop is provided with the unit (located behind the grille). Additional 90° door stop kits are available through an authorized Sub-Zero dealer.

WARNING: Follow all city and state laws when storing, recycling, or discarding unused refrigerators and freezers.

Warning

This content is compiled from multiple sources and is provided for reference purposes only. It may not be complete or fully applicable to all situations. If you are unable to resolve your issue, please contact the product manufacturer or an authorized service provider for official support.