

PARTS DESCRIPTION

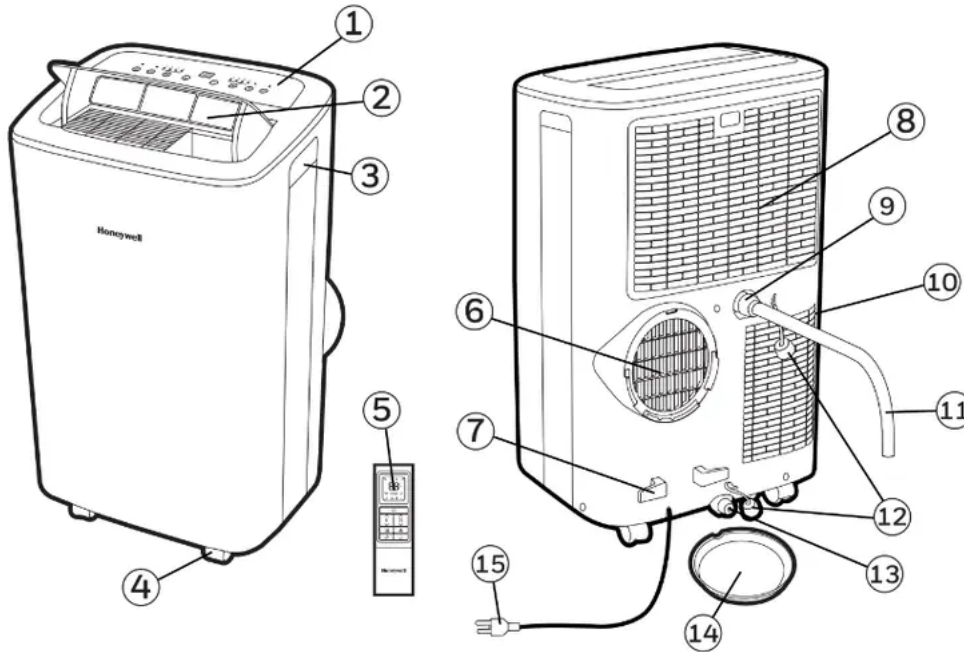

1. Control Panel
2. Air Outlet
3. Handle
4. Casters
5. Remote Control
6. Hose Connector
7. Cord Winder
8. Upper Dust Filter
9. Upper Rubber Drain Plug (Dehumidifying Mode)
10. Lower Dust Filter
11. Drain Tube (For Continuous Drain)
12. Drain Plug Cap
13. Lower Rubber Drain Plug (Air Conditioning Mode)
14. Drain Pan
15. Power Supply Cord

INSTALLATION

It is important that the installation instructions below are followed for successful installation of this Portable Air Conditioner. Please call Customer Support if you have any difficulties or queries regarding these installation procedures.

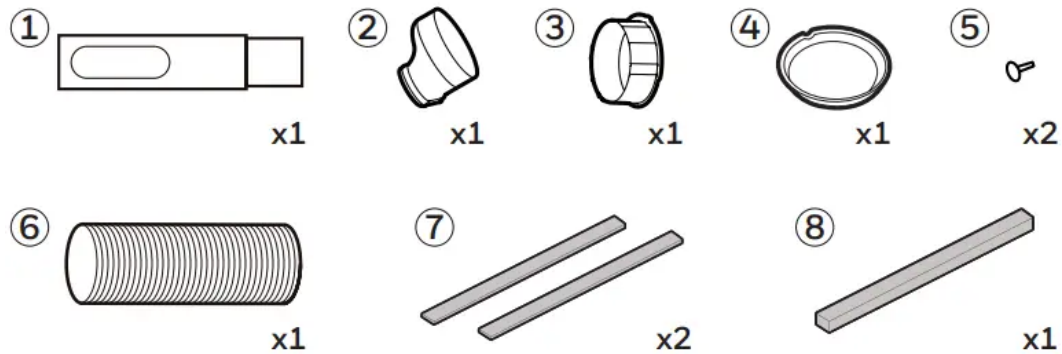

Installation Kit:			
1. Window Bracket Kit	(1 Set)	5. Plastic Pin	(2 Pieces)
2. Window Bracket Panel Adapter	(1 Piece)	6. Hose	(1 Piece)
3. Hose Connector	(1 Piece)	7. Foam Seal (adhesive)	(2 Pieces)
4. Drain Pan	(1 Piece)	8. Foam Seal (non-adhesive)	(1 Piece)

Installation Steps:

1. Window bracket panel adapter, hose and hose connector are pre-assembled inside the package.

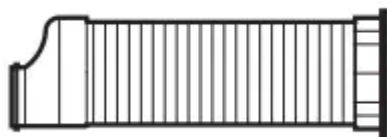

2. Adjust the window bracket as per width or height of your window and insert the plastic pin to fix at the desired position. There is a hole where the hose will be inserted later. Make sure this hole is not blocked.

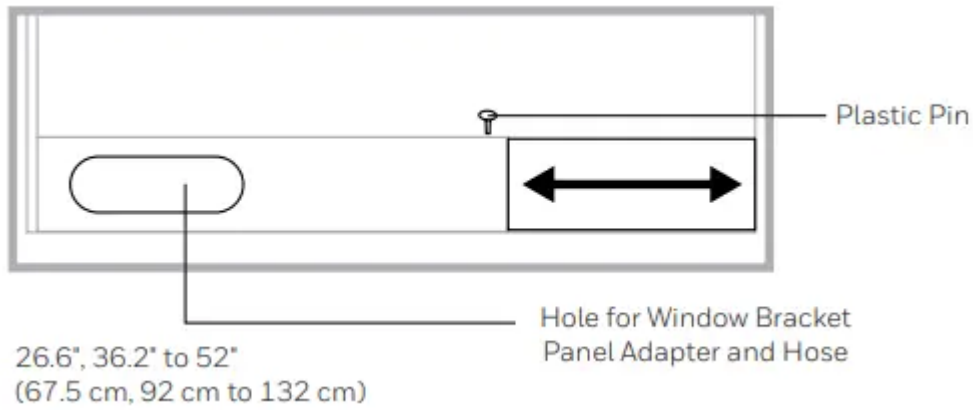

Note: After setting the window bracket to the size of your window, please remove it from the window and follow the instructions below.

3. Connect the hose to the rear exhaust outlet on the back of the unit. Slide-in the hose connector then rotate clockwise until it is locked in place.

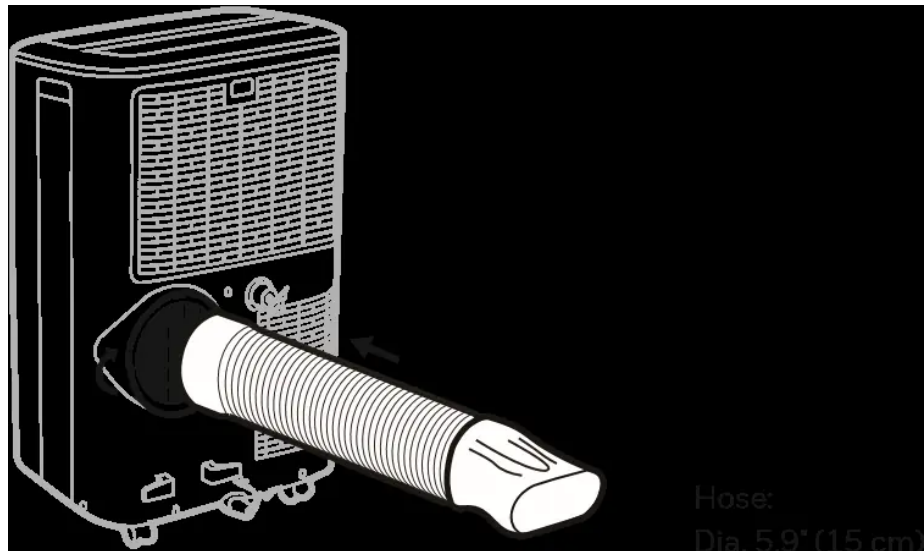

Length: 10.6" to 59" (27 cm to 150 cm)

4. Connect the window bracket to the window bracket panel adapter. Ensure that all connections are tight and installed properly.

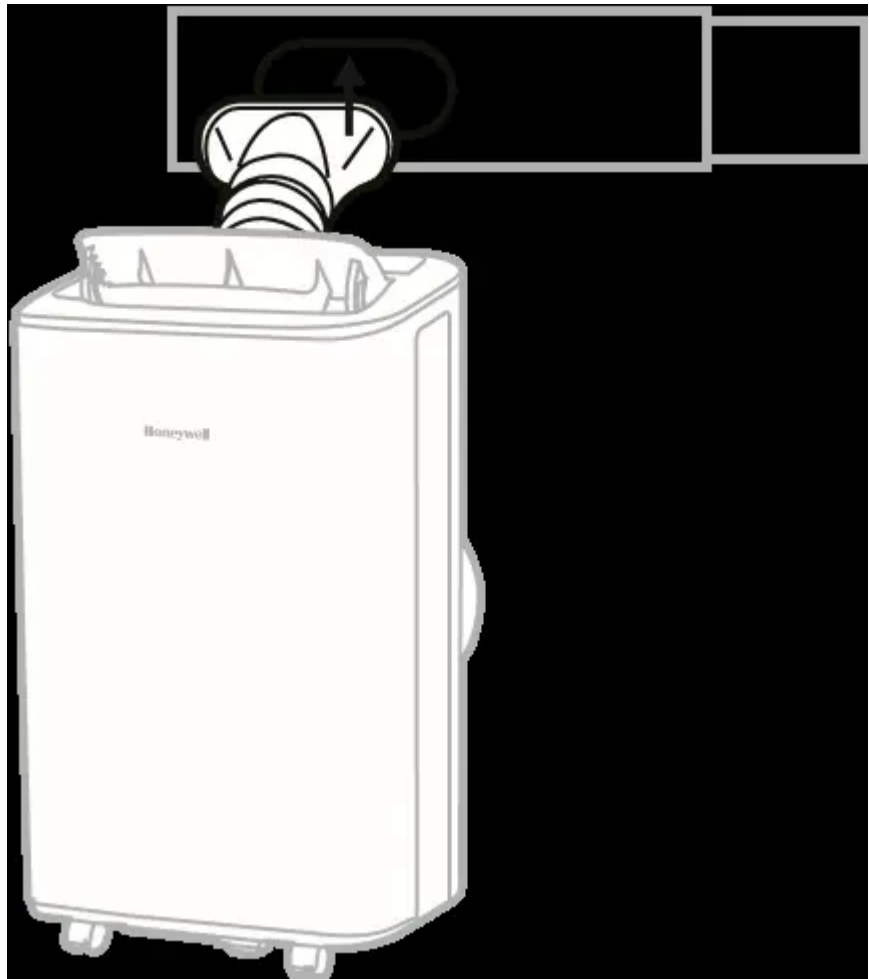

5. Cut the Foam Seal (adhesive) to the proper length and attach them to the window sash and frame.



Horizontal Sliding Window

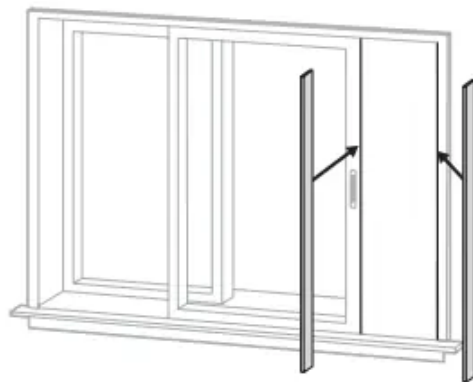

Vertical Sliding Window

6. Connect the window bracket to the window.



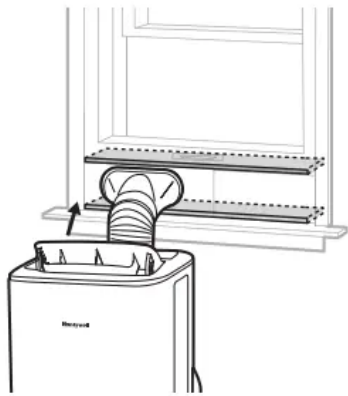

Horizontal Sliding Window

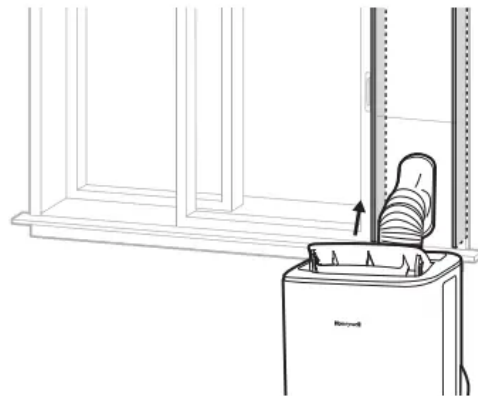

Vertical Sliding Window

7. Cut the Foam Seal (non-adhesive) to the window length. Stuff the Foam Seal (non-adhesive) between the inner window sash and the outer window glass to prevent air and insects from getting into room.

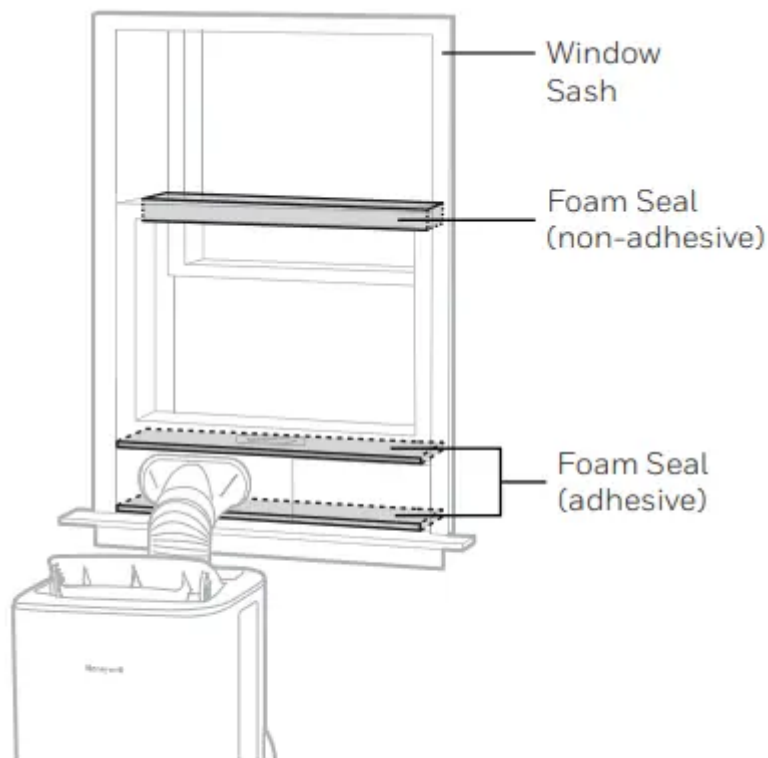

Horizontal Sliding Window



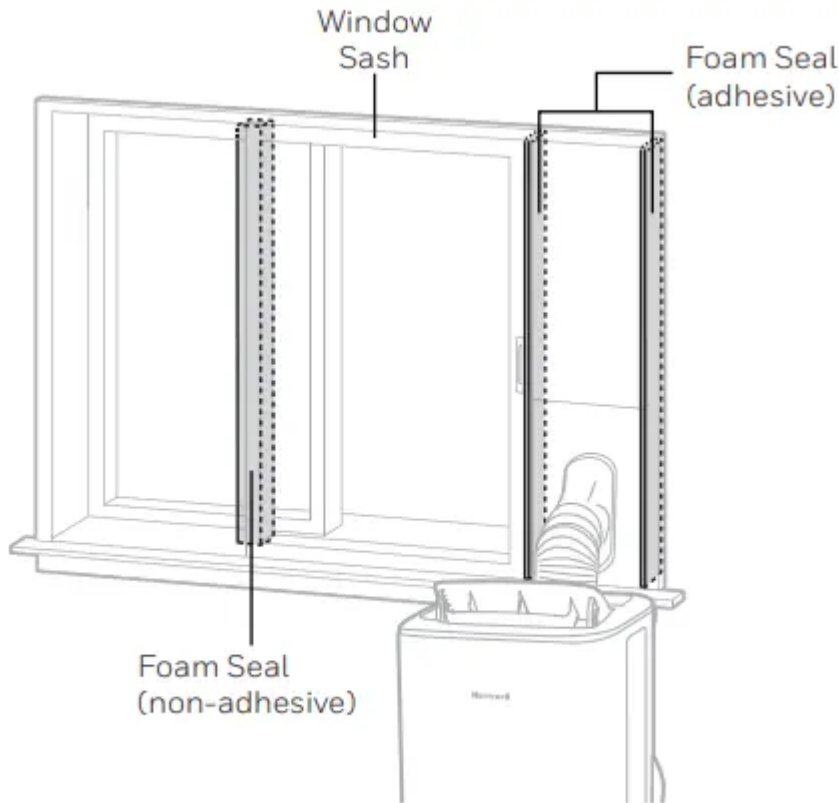

Vertical Sliding Window

8. The Portable Air Conditioner is now ready to use.

IMPORTANT: Do not replace or lengthen the hose as this could cause the unit to malfunction.

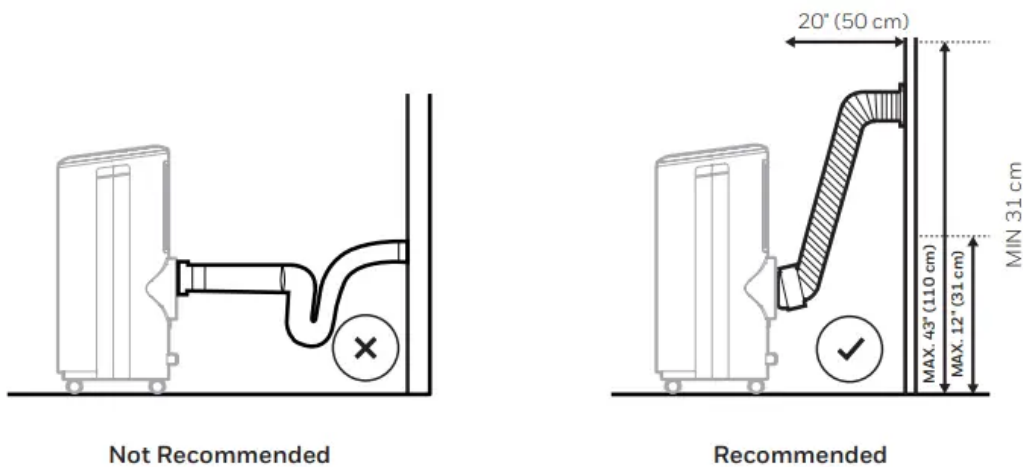

WARNING: Any warranties included with this product will be voided if an extra extension hose is added to the originally provided installation kit or if the installation is performed differently than the manufacturer's instructions, without proper consultation. Please contact Customer Support for help with installation procedures if needed.

- The supplied hose has a diameter of 5.9" (15 cm) and can be extended from



- 10.6" to 59" (27 cm to 150 cm).
- Do not bend (to the extent shown below) the hose. A bent hose will block exhaust air and cause the unit to malfunction or shut-off.
- Make sure the back of the unit is at least 20" (50 cm) away from the wall. Do not place the unit in front of curtains or drapes as this could obstruct the airflow.

USE AND OPERATION

CONTROL PANEL



1) Indicator Lights	5) Timer / Temperature Set Controls
2) Power Control	6) Mode Control
3) Filter Reset	7) Timer Control
4) Fan Speed Control	8) Sleep Control
9) Wi-Fi Connectivity and Voice Activated Control	

THIS IS ONLY FOR MODEL HF08CESVWK / HF10CESVWK WITH WIFI SMART FEATURES

NOTE: For detailed instructions to set up your Portable Air Conditioner for connected operation from your smart phone or tablet, separate user manual can be downloaded at:

FUNCTION BUTTONS

POWER CONTROL 

The Power Control  turns the unit on and off. The air vent will automatically open when the unit is turned ON and automatically close when unit is turned OFF.

FILTER RESET 



When the operation has reached 250 hours, the Filter Reset light will illuminate. Switch the Portable Air Conditioner OFF and carefully remove filters from the unit and clean. Replace filters and press the Filter Reset button, the Filter Reset light will turn off and the operation time will be cleared.



FAN SPEED CONTROL

4 settings: High, Medium, Low and Auto.

Note: Auto fan speed can be selected in cooling mode only.

TEMPERATURE CONTROL

- The default display is setting temperature.
- In cooling mode, when  or  button is pressed, the set temperature is displayed and may be adjusted.

Note: By pressing both  or  buttons at the same time, the display will toggle between Celsius (°C) and Fahrenheit (°F).

MODE CONTROL

Settings: Air Conditioning, Dehumidifying, Fan, Auto. The corresponding indicator light will illuminate to indicate the current mode setting.

- **Air Conditioning Mode (COOL)** 

Adjust fan speed and air temperature to suit your desired comfort level.

Temperature setting range is 16°C - 32°C (60°F - 90°F).

Ambient temperature range is 16°C - 35°C (60°F - 95°F).

- **Dehumidifying Mode (DRY)** 

Fan speed is preset to Low.

Note: If the unit will be used mainly as a dehumidifier, do not connect the hose. Continuous drainage is then necessary (refer to Continuous Draining for Dehumidifier Mode).



IMPORTANT: The Dehumidifier mode is used to support moisture reduction but should not be expected to dehumidify to the same degree as a standard dehumidifier-only appliance. The built-in dehumidifier automatically adjusts dehumidification based on ambient room temperatures. It is not possible to adjust to a desired humidity percentage. The front display only shows the current and desired temperatures. It does not show humidity levels.

- **Fan Mode** 

For air circulation without air conditioner cooling.

Note: Auto fan speed cannot be selected in fan mode.

• Auto Mode

Press the  or  button to select the temperature you want.



In this mode, the unit will automatically select cooling or fan only depends on the set temperature and the room temperature. The Portable Air Conditioner will control room temperature automatically around the set temperature.

Note: Fan speed can't be adjusted in auto mode.



TIMER CONTROL

The Timer is adjustable between 1 - 24 hours.

AUTO TURN OFF:

While unit is running, press the Timer button  and the display will flash. While the display is flashing, press the  or  button to select the number of hours you want the unit to turn OFF automatically.

AUTO TURN ON:

When unit is in a standby mode (plugged in with power light will on for seconds when plugged then turn off), press the Timer button  and the display will flash. While the display is flashing, press the  or  button to select the number of hours until you want the unit to turn ON automatically.

SLEEP MODE

When the Sleep Mode is activated in Air Conditioning mode, the set temperature will increase by 1°C or 1°F after the first hour of cooling and will increase a further 1°C or 1°F after the second hour of cooling. The unit will maintain this temperature for 5 hours. The set temperature will then reduce by 1°C or 1°F on the seventh hour and reduce a further 1°C or 1°F on the tenth hour. Sleep mode will then deactivate automatically.

Note: The Sleep Mode can be deactivated during cooling mode by pressing any button at any time.

WATER FULL ALARM

Condensation may accumulate in the unit. If the internal tank is full, error code "P1" will be displayed and an alarm will beep for 3 seconds. The unit will not operate until the water has been drained from the lower drain plug (refer to Water Condensation Drainage).

After switching the Portable Air Conditioner off, the compressor will not start immediately. You must wait about 4 minutes before it switches back on again.

WI-FI MODE

When the Smart Portable Air Conditioner is connected to the wifi function, the indicator light will be illuminated.



THIS IS ONLY FOR MODEL HF08CESVWK / HF10CESVWK WITH WI-FI SMART FEATURES

REMOTE CONTROL

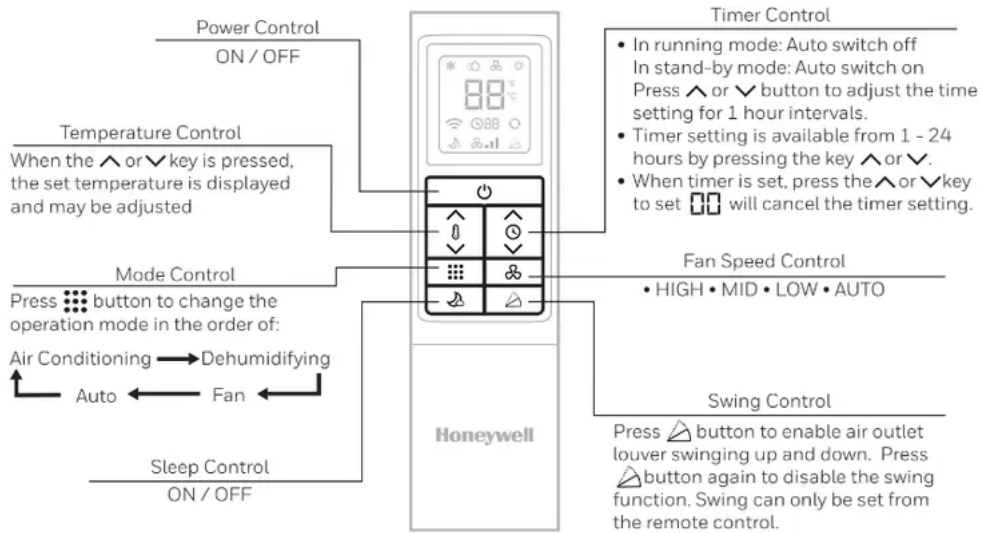

Note:

- **Battery Installation:** Remove the cover on the back of the remote control and insert two AAA batteries with + and - pointing in the proper direction according to the polarity markings.

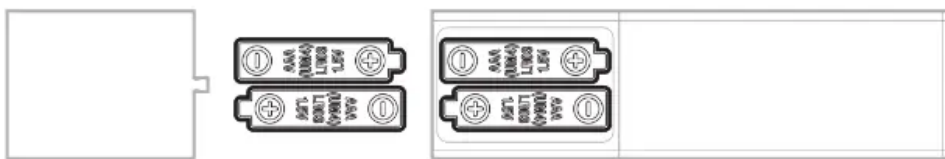

Caution:

- Use only two AAA or IEC R03 1.5V batteries.
- Remove the batteries if the remote control is not in use for a month or longer.
- All batteries should be replaced at the same time, do not mix with old batteries.
- Do not mix alkaline, standard (carbon-zinc) or rechargeable (nickel-cadmium) batteries.
- Properly dispose of used batteries.

This device complies with part 15 of the FCC Rules. Operation is subject to following two conditions: (1) this device may not cause harmful interference, and (2) this device must accept any interference received, including interference that may cause undesired operation.



This equipment has been tested and found to comply with the limits for a Class B digital device, pursuant to part 15 of the FCC Rules.

These limits are designed to provide reasonable protection against harmful interference in a residential installation. This equipment generates, uses and can radiate radio frequency energy and, if not installed and used in accordance with the instructions, may cause harmful interference to radio communications. However, there is no guarantee that interference will not occur in a particular installation. If this equipment does cause harmful interference to radio or television reception, which can be determined by turning the equipment off and on, the user is encouraged to try to correct the interference by one or more of the following measures:

- Reorient or relocate the receiving antenna.
- Increase the separation between the equipment and the receiver.
- Connect the equipment into an outlet on a circuit different from that to which the receiver is connected.
- Consult the dealer or an experienced radio/ TV technician for help.

Caution: Any changes or modifications not expressly approved by the party responsible for compliance could void the user's authority to operate the equipment.

CLEANING AND MAINTENANCE

Appliance Maintenance:

1. Turn off the appliance before disconnecting the power supply.
2. Only clean the appliance with a soft dry cloth.

Dust Filter Maintenance:

The dust filter is to be cleaned every two weeks to maintain air cooling efficiency. Please follow the below instructions for cleaning the dust filters:

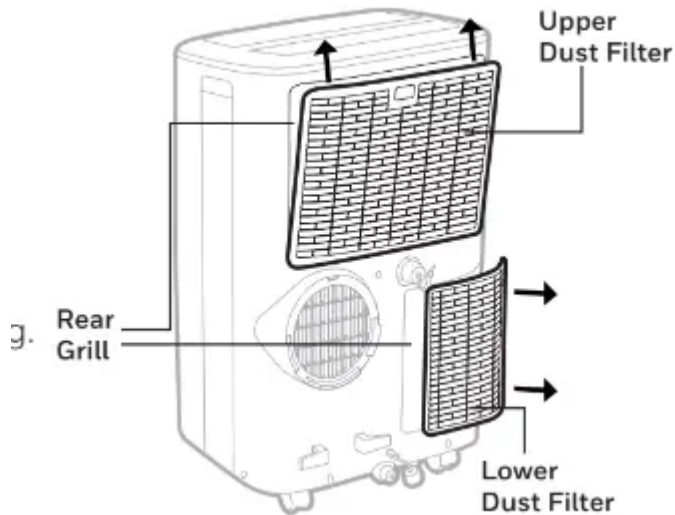

1. Switch off and unplug the Portable Air Conditioner from the electrical outlet.
2. Remove the Upper Filter/ Grill, unscrew the Lower Filter/ Grill and carefully remove.
3. Gently wash using water and/ or diluted liquid dishwashing detergent. Rinse thoroughly and gently shake excess water from the filters. Make sure the filters are dry before reinstalling. **Note:** You may use a vacuum cleaner to remove dust.
4. Replace the Upper Grill onto the unit, and reinstall the Lower Grill with the screw.

WARNING: DO NOT power or operate the Portable Air Conditioner when cleaning or when the Dust Filter is removed from the unit, or if there is a loose-fitting Dust Filter. DO NOT attempt to handle or touch any of the parts or wiring inside the Rear Grill after the Dust Filter has been removed from the unit. Doing so can cause serious injury or electrical shock.

End of Season Storage and Maintenance:

If the appliance will not be used for a long time, follow these steps:

1. Be sure to drain the left-over water condensation. Remove the lower drain plug and use a drain pan to collect the water (make sure to replace the drain plug cap when finished).
2. To dry excess moisture, run the unit in Fan only mode for 30 minutes before storing.
3. Turn off and unplug the Portable Air Conditioner from the power supply.
4. Remove the dust filter and clean with water. Dry the dust filter and then reinstall.
5. Disconnecting the Window Installation Kit:
 - Remove the Hose from the unit by rotating anti-clockwise then pulling away.
 - Remove the Foam Seal, Window Bracket, Window Bracket Panel Adapter and Hose Connector.
 - It is recommended to store the Window Kit parts in a bag together with the Remote Control, Drain Tube and placing them together with the Portable Air Conditioner unit.

- If needed, you can clean the Window Kit with a damp cloth and water before storing. Make sure all parts of the Window Kit are dry before storage.
6. Cover the Portable Air Conditioner with a cloth/ plastic bag before storage, to protect from dust and scratches collecting on the surface of the unit.
 7. It is recommended to coil the power cord before storing to ensure the cord is protected from bents and creases.
 8. Store the Portable Air Conditioner in a cool, dry place, away from direct sunlight.

WATER CONDENSATION DRAINAGE

When there is excess water condensation inside the unit, the Portable Air Conditioner stops running and shows an error code "P1" with an alarm. This indicates that the water condensation needs to be drained using the following procedures:

Manual Draining in Cooling, Dehumidifying and Auto Modes

Water may need to be drained in high humidity areas.

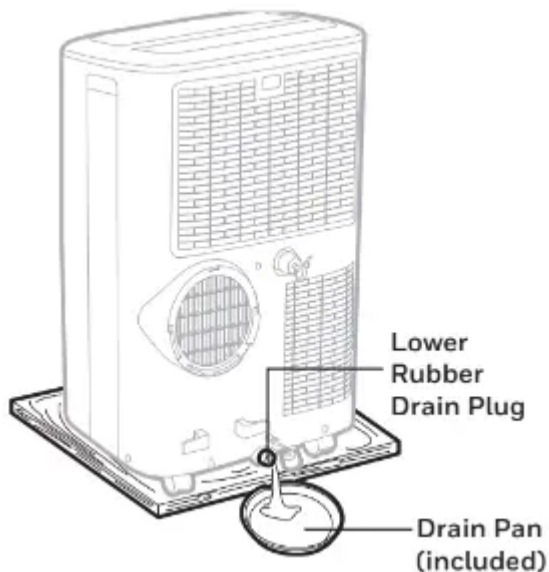

1. Unplug the unit from power source.
2. Place a drain pan under the lower rubber drain plug. See diagram.
3. Remove the drain plug cap.
4. Water will drain out and collect in the drain pan.
5. After the water is drained, replace the drain plug cap.
6. You can now turn on the unit.

Continuous Draining in Dehumidifier Mode

While using the unit in dehumidifier mode, continuous drainage is recommended.

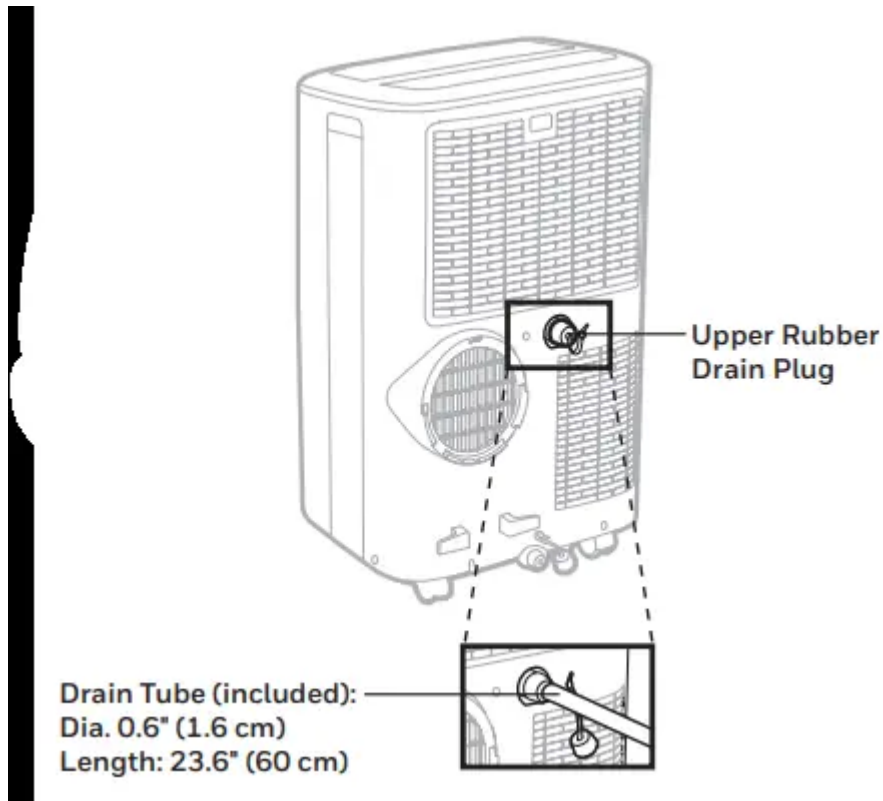

1. Unplug the unit from power source.
2. Remove the upper drain plug cap. Some residual water may spill so please have a pan to collect the water.
3. Connect the drain tube (included) to the upper drain plug. See diagram.
4. The water can be continuously drained through the drain tube into a floor drain or bucket.
5. Replace the drain plug cap.
6. You can now turn on the unit.

IMPORTANT: It is NOT recommended to connect the drain hose for continuous drainage while the unit is switched ON in air conditioning cooling mode. Doing so can reduce the cooling efficiency of the Portable Air Conditioner. Only drain the water condensation when the unit is switched off. Continuous drainage is only suitable when the unit is set up in Dehumidifier mode.

TROUBLESHOOTING GUIDE

The following troubleshooting guide addresses the most common problems. If problems persist, call customer support. Unplug and disconnect the appliance from the power source before attempting to troubleshoot.

PROBLEM	POSSIBLE CAUSE	SOLUTION
The air conditioning unit does not start	No electricity.	Check for power.
	Batteries in the remote control need to be replaced.	Change remote control batteries.
	The power cord is not properly plugged in.	Remove and reconnect the power cord.
	The safety LCDI plug has tripped (USA / Canada / Mexico only).	Reset the safety LCDI plug, if problem persists contact our customer support (USA / Canada / Mexico only).
Runs a short while only	The thermostat temperature setting is too close to room temperature.	Lower the set temperature.
	Air outlet is blocked.	Make sure the hose is properly connected.
	There are tight bends in the air hose.	Connect hose as per instructions on page 3.
Runs but not cooling	A door or window is open.	Make sure the window or door is closed.
	The dust filter is dirty.	Clean the dust filter.
	The hose is detached.	Reinstall hose properly (refer to Installation section).
	Temperature setting is too high.	Reduce temperature setting.
	Air outlet or intake is blocked.	Remove blockage.

	Room exceeds recommended size.	Move unit to smaller room.
	Large size or number of windows are decreasing cooling effectiveness.	Cover windows with curtains or blinds.
Will not run and error code "P1" is displayed	Excess water condensation inside the tank.	Drain the water (refer to Water Condensation Drainage).

ERROR CODE GUIDE

ERROR CODE	ERROR POSSIBLE CAUSE
"E1"	Indoor temperature sensor failure (open circuit or short circuit).
"E3"	Evaporator temperature sensor failure (open circuit or short circuit).
"P1"	Water full alarm.

Warning

This content is compiled from multiple sources and is provided for reference purposes only. It may not be complete or fully applicable to all situations. If you are unable to resolve your issue, please contact the product manufacturer or an authorized service provider for official support.