

Components Description.

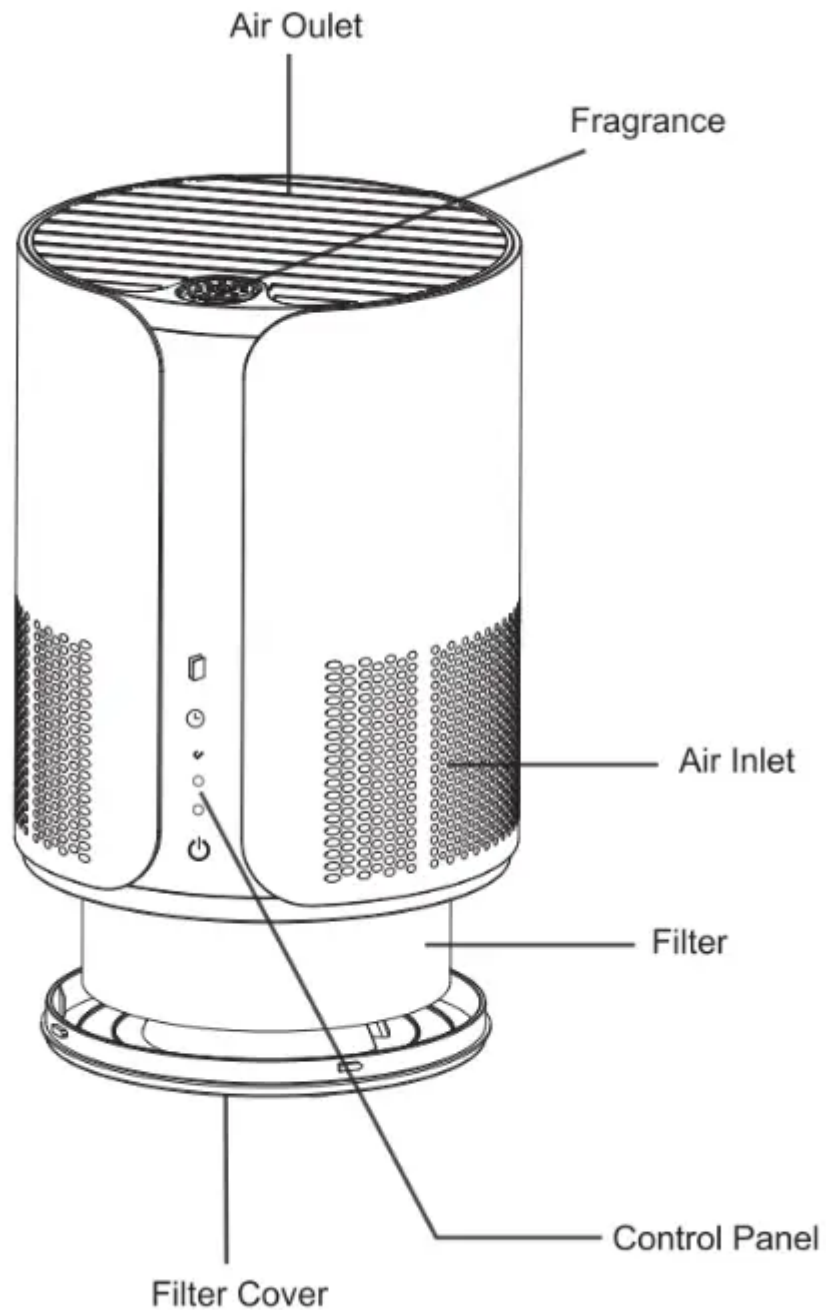

Preparation Before Use

Aromatherapy box / Filter installation (Make sure to do it before the power plug is plugged-in into the socket)

1.1 Disassemble the filter cover at the bottom of the air inlet. Place the bottom of the filter in your hand, make sure it covers it completely. Press down slightly and turn left as shown by the arrow. This will let you remove and release the bottom cover. (Power will shut off automatically when the bottom cover is open).

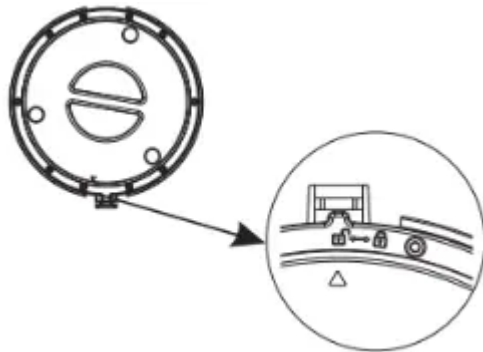

2. Remove the PE bag containing the filter.
The filter has been placed inside the purifier.
Grab the filter bag and take out the filter.

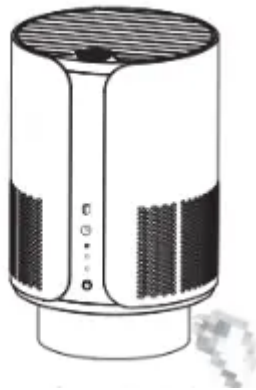

3. Take the filter out of the plastic bag



4. Install the filter.

1. Insert the filter into the device after removing the PE plastic bag.
2. Once the filter cover is back in position, turn it to the right to lock it.

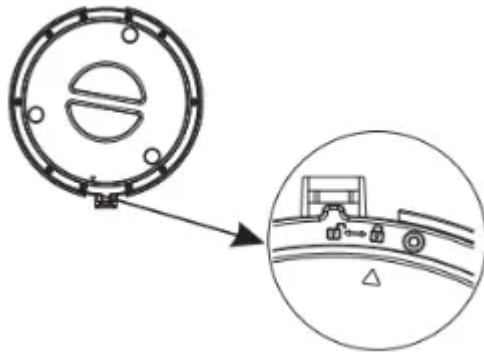

5. Install the aromatherapy box.



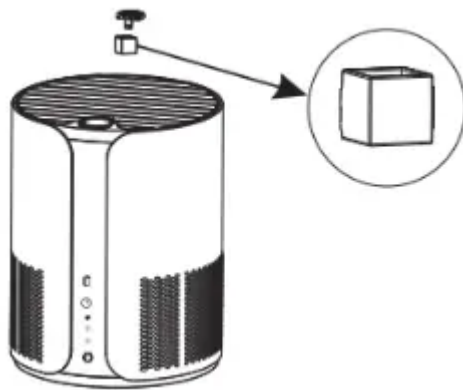



The aromatherapy box is already installed in the unit. If you need to add or replace the essential oils, please take it out. Then do as shown in the picture: Place the aromatherapy box into the machine. (Please pay attention to the installation directions).



Fragrance/Filter Installation

Touch screen button operation + display instructions:

When the power is turned on for the first time, the buzzer will beep and all the display buttons will light up and the indicator will go off.

-  Filter reset switch
-  Timer switch
-  Speed indicator
-  Medium speed indicator
-  Low speed indicator
-  Switch

Power button

In the standby mode, tap the "Switch" button, the machine then will enter the power on mode.

After power is turned on, the wind speed will default to low-level operation; this would be shown accordingly in the lights control panel display.

While in the power on mode, press and hold the "Switch" button for 3 seconds to enter the standby mode.

Wind speed gear button:

In the power-on mode, the default wind speed is low. If you need to switch the wind speed, you can touch the "switch" button.

Each time the "Switch" is tapped, the wind speed gear will shift between the different speed modes: low speed, medium speed, extreme speed and back to low speed (Default mode).

Timer:

1: When the power is on, press the "Timer" button, the timer indicator light will blink to show that the machine would be turned off after 4 hours. Press the "Timer" button again, the timer indicator light will remain fixed on to indicate that the machine would turn off after 8 hours. Press the "Timer" button, one more time. The timer indicator light will turn off to show that timer function has been canceled.

Filter reset:

When the purifying filter replacement reminder light is on, please turn off the power and replace the purifier filter. After the replacement is completed, press and hold the "Reset" button for 3 seconds, the buzzer will sound once, the replacement reminder will reset, and the reminder light will go off.

Aromatherapy module:

After removing the aromatherapy cover, the aromatherapy block can be taken out and the essential oils can be dripped into the unit. The essential oils, then, would be evenly distributed through the air.

Product Troubleshooting

Machine cannot work

- The power is not on.
 - Turn it on.
- Power plug is loose.
 - Pull out the plug and pull it in again.

Foul smell coming from the air outlet

- The filter has absorbed too much foul smell or dust.
 - Change the filter.

Bad performance

- Indoor air is too dry.
 - Increase indoor humidity accordingly.
- There's not enough space around the machine.
 - Change placement, remove obstacles.

No air is blown out

- There is a foreign body blocking the outlet or the filter's packing bag has not been removed.
 - Take out the foreign body and remove the filter's packing bag.

Maintenance

Whenever the device needs to be maintained, checked or moved, please, turn it off and unplugged it. Please do not handle the power cord with wet hands. Doing so, could result in electric shock and other related injuries.

Main body

After one month

Please use soft cloth to clean the surface of the air purifier's body. If the stain is too deep, please use a warm wet cloth or a neutral detergent to clean it, then wipe it out with a dry clean cloth

In order to have a good purification effect and a long lasting usage, please keep up with the regular preventive maintenance care.

Attention

- Do not use hot water (Higher than 40 C). It may cause color fading.
- Do not use pesticides or other chemical detergents.
- Never wash the air purifier's body with running water.

Filter

There's one set filter inside the machine that can not be washed.

It is suggested to change the filter every three months.

All new filters should be bought directly from us or our company agents.

Long idle time

1. Pull out the powercord.

2. Cover the machine with a plastic bag and place it in a dry safe place.
 3. Do not store it in an upside down position; it could lead to product malfunction.
- insecticide oil paint



Replacing the filter

Caution: The machine should be cut-off the power before following these maintenance steps.

1. Remove the PE bag

When using the air purifier for the first time, please open the bottom cap, take out the filter and make sure to remove the plastic bag that covers it. Otherwise the filter will not purify the air properly.

Keep away the plastic bag out of the reach of children to avoid any accident.

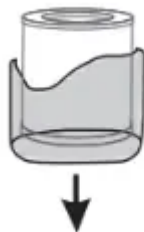

2. Clean or change the filter

1. Take the filter out from the air purifier, as shown in Figure A.
2. Remove the packing bag from the new filter as shown in Figure B.
3. Put the new filter inside the machine and re-arrange the bottom cap as shown in Figure C.

4. Plug in the power cord and turn on the machine. Long press the FILTER RESET button for 3s. The filter reset indicator light will turn off, meaning that the reset was successful.

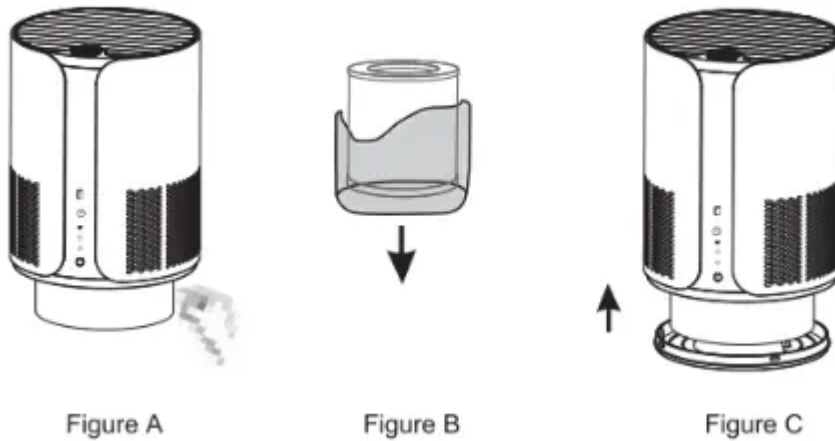

Warning

This content is compiled from multiple sources and is provided for reference purposes only. It may not be complete or fully applicable to all situations. If you are unable to resolve your issue, please contact the product manufacturer or an authorized service provider for official support.