

## Use & Care Guide for Refrigerator

### REFRIGERATOR USE

#### Ensuring Proper Air Circulation

In order to ensure proper temperatures, you need to permit air to flow between the two sections. Cold air enters the bottom of the freezer section and moves up. It then enters the refrigerator section through the top vent. Air then returns to the freezer as shown.

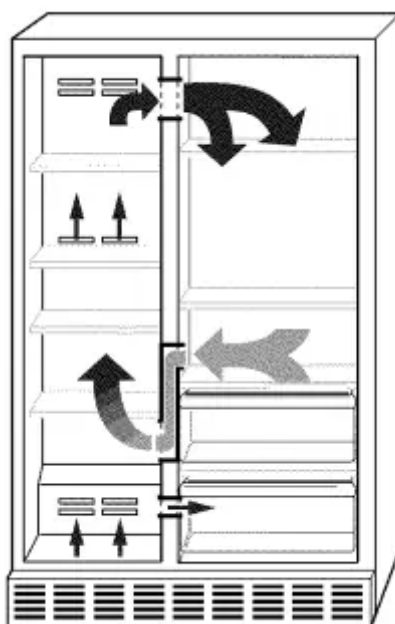

Do not block any airflow vents. If the vents are blocked, airflow will be obstructed and temperature and moisture problems may occur.

**IMPORTANT:** Because air circulates between both sections, any odors formed in one section will transfer to the other. You must thoroughly clean both sections to eliminate odors. To avoid odor transfer and drying out of food, wrap or cover foods tightly.

#### Using the Controls

For your convenience, your refrigerator controls are preset at the factory. When you first install your refrigerator, make sure that the controls are still preset. The Refrigerator Control and the Freezer Control should both be set to the “mid-settings.”

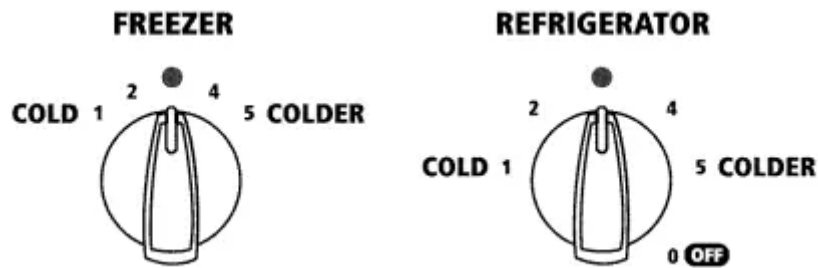

**IMPORTANT:**

- Your product will not cool when the REFRIGERATOR Control is set to OFF.
- The Refrigerator Control adjusts the refrigerator compartment temperature. The Freezer Control adjusts the freezer compartment temperature. Settings to the left of the mid-setting make the temperature less cold. Settings to the right of the mid-setting make the temperature colder.
- Wait 24 hours before you put food into the refrigerator. If you add food before the refrigerator has cooled completely, your food may spoil.

**NOTE:** Adjusting the Refrigerator and Freezer Controls to a higher (colder) than recommended setting will not cool the compartments any faster.

**Adjusting Controls**

Give the refrigerator time to cool down completely before adding food. It is best to wait 24 hours before you put food into the refrigerator. The settings indicated in the previous section should be correct for normal household refrigerator usage. The controls are set correctly when milk or juice is as cold as you like and when ice cream is firm.

- Turn the control right (clockwise) to make the compartment colder.
- Turn the control left (counterclockwise) to make it less cold.
- To turn the cooling system off, turn the Refrigerator Control counterclockwise until it reaches the OFF position.

If you need to adjust temperatures in the refrigerator or freezer, use the settings listed in the chart below as a guide. Wait at least 24 hours between adjustments.



<b>CONDITION/REASON:</b>	<b>ADJUSTMENT:</b>
<b>REFRIGERATOR too warm</b>	REFRIGERATOR Control one setting higher
<b>FREEZER too warm/too little ice</b>	FREEZER Control one setting higher
<b>REFRIGERATOR too cold</b>	REFRIGERATOR Control one setting lower
<b>FREEZER too cold</b>	FREEZER Control one setting lower

## **Water and Ice Dispensers**

Depending on your model, you may have one or more of the following options: the ability to select either crushed or cubed ice, a special light that turns on when you use the dispenser, or a lock option to avoid unintentional dispensing.

### **NOTES:**

- The dispensing system will not operate when either door (refrigerator or freezer) is open.
- Allow 24 hours for the refrigerator to cool down and chill water.
- Allow 24 hours to produce the first batch of ice. Discard the first three batches of ice produced. Wait 72 hours for full ice production. Also, take large amounts of ice from the ice bin, not through the dispenser.

### **Flush the Water System**

Air in the water dispensing system can cause the water dispenser to drip. After connecting the refrigerator to a water source or replacing the water filter, flush the water system. Flushing the water dispensing system forces air from the water line and filter, and prepares the water filter for use.

**NOTE:** As air is cleared from the system, water may spurt out of the dispenser.

1. Using a sturdy container, depress and hold the water dispenser lever for 5 seconds, then release it for 5 seconds.
2. Repeat Step 1 until water begins to flow.
3. Once water begins to flow, continue depressing and releasing the dispenser lever (5 seconds on, 5 seconds off) until a total of 3 gal. (12 L) has been dispensed.

Additional flushing may be required in some households.

### **The Water Dispenser**



**IMPORTANT:**

- Dispense at least 1 qt (1 L) of water every week to maintain a fresh supply.
- If the flow of water from the dispenser decreases, it could be caused by low water pressure.
- With the water filter removed, dispense 1 cup (237 mL) of water. If 1 cup of water is dispensed in 8 seconds or less, the water pressure to the refrigerator meets the minimum requirement.
- If it takes longer than 8 seconds to dispense 1 cup of water, the water pressure to the refrigerator is lower than recommended. See “Water Supply Requirements” or “Problem Solver” for suggestions.

**To Dispense Waters**

1. Press the WATER button to select water.



2. Press a sturdy glass against the dispenser lever. Hold the glass close to the water dispenser spout to ensure that the water dispenses into the glass.

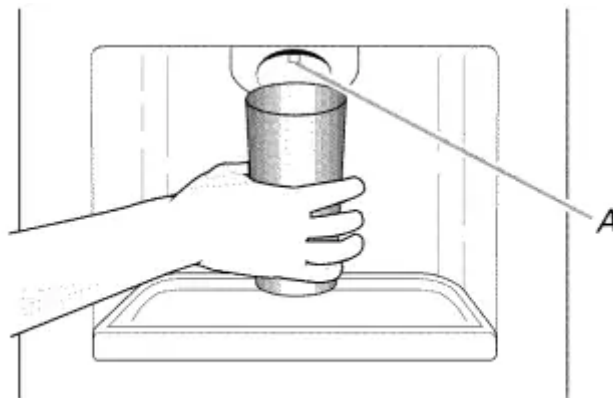

*A. Water dispenser spout*

3. Remove the glass to stop dispensing.

**IMPORTANT:** The small tray at the bottom of the dispenser is designed to catch small spills and allow for easy cleaning. There is no drain in the tray. To empty and clean the tray, push down on the back of the removable tray lid and pull it out.

### **The Ice Dispenser**

Ice dispenses from the ice maker storage bin in the freezer. When the dispenser lever is pressed, a trap door opens in a chute between the dispenser and the ice bin. Ice moves from the bin and falls through the chute. When you release the dispenser lever, the trap door closes and the ice dispensing stops.

Some models dispense both cubed and crushed ice. Before dispensing ice, select which type of ice you prefer.

- Press the CRUSHED button for crushed ice, or the CUBED button for cubed ice.

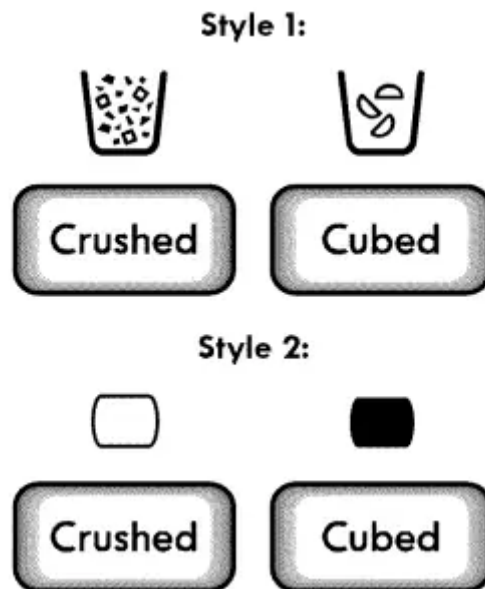

For crushed ice, cubes are crushed before they are dispensed. This may cause a slight delay when dispensing crushed ice. Noise from the ice crusher is normal, and pieces of ice may vary in size. When changing from crushed to cubed, a few ounces of crushed ice will be dispensed along with the first cubes.

### **To Dispense Ice:**

1. Press button for the desired type of ice.

#### **WARNING Cut Hazard**

**Use a sturdy glass when dispensing ice.**

**Failure to do so can result in cuts.**

2. Press a sturdy glass against the dispenser lever. Hold the glass close to the ice guide to ensure that the ice dispenses into the glass.

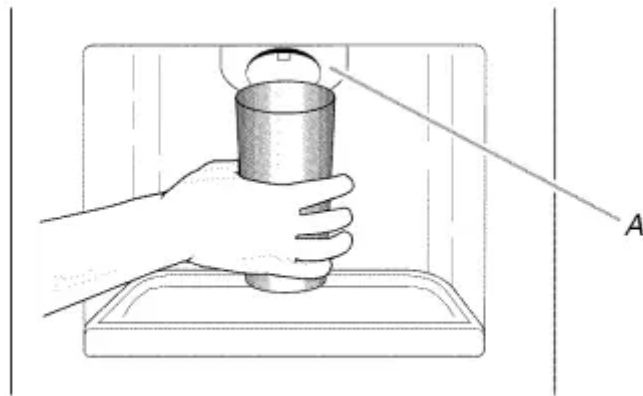

A. Ice guide

**IMPORTANT:** You do not need to apply a lot of pressure to the lever in order to activate the ice dispenser. Pressing hard will not make the ice dispense faster or in greater quantities.

3. Remove the glass to stop dispensing.

**NOTE:** Ice may continue to dispense for several seconds after removing the glass. The dispenser may continue to make noise for a few seconds after dispensing.

### **The Dispenser Light**

On some models, the dispenser light will automatically turn on when you use the dispenser.

- If you want the light to be on continuously, press the LIGHT ON button. To turn the light back off, press the LIGHT OFF button.

#### **Style 1:**

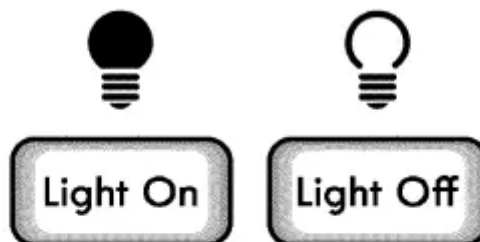

#### **Style 2:**

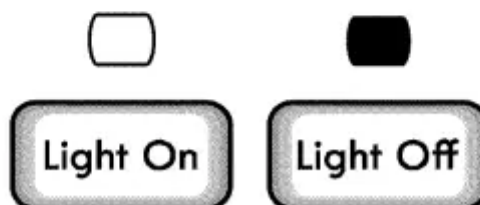

The dispenser lights are LEDs that cannot be changed. If it appears that your dispenser lights are not working, see “Problem Solver” for more information.

### **The Dispenser Lock**

The dispenser can be turned off for easy cleaning or to avoid unintentional dispensing by small children and pets.

**NOTE:** The lock feature does not shut off power to the refrigerator, to the ice maker, or to the dispenser light. It simply deactivates the dispenser lever. To turn off the ice maker, see “Ice Maker and Storage Bin.”

- To lock the dispenser, press the LOCK button. To unlock the dispenser, press the UNLOCK button.

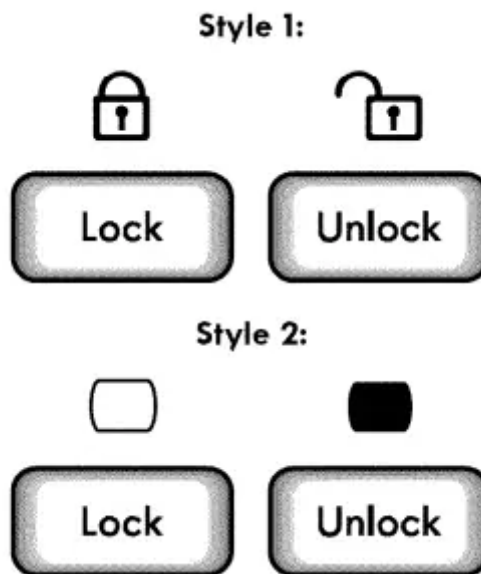

## Water Filtration System

Do not use with water that is microbiologically unsafe or of unknown quality without adequate disinfection before or after the system. Systems certified for cyst reduction may be used on disinfected waters that may contain filterable cysts.

### Water Filter Status Light (on some models)

The filter status light will help you know when to change your water filter.

- The light will change from green to yellow. This tells you that it is almost time to change the filter
- It is recommended that you replace the filter when the status light changes to red OR water flow to your water dispenser or ice maker decreases noticeably.

**NOTE:** The filter should be replaced at least every 6 months depending on your water quality and usage.

### Resetting the Filter Status

- The reset button is located on the control panel in the refrigerator compartment. To reset the status light after changing the filter, press the button 5 times within 10 seconds.

The status light will change from red to green when the system is reset.

### **Non-Indicator Water Filter (on some models)**

If your refrigerator does not have the water filter status light, you should change the water filter cartridge at least every 6 months depending on your water quality and usage. If the water flow to the water dispenser or ice maker decreases noticeably before 6 months have passed, replace the water filter more often.

### **Changing the Water Filter**

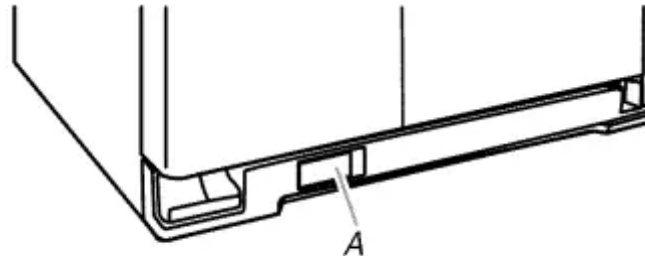

*A. Water filter cover door*

1. Locate the water filter cover door in the base grille, and pull open the filter door. The filter will be released and then be ejected as the door is opened.
2. When the door is completely open, pull the filter straight out.

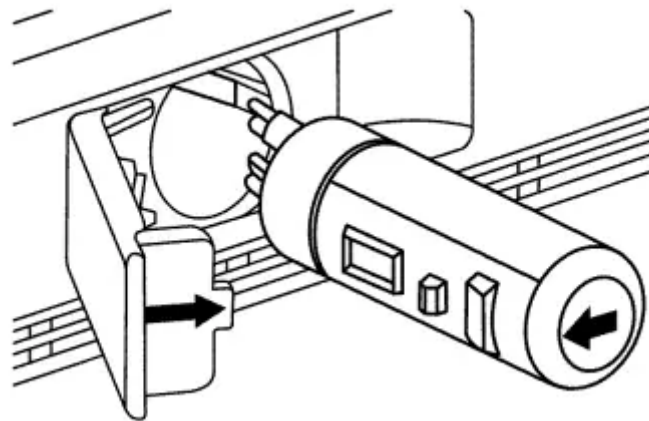

**NOTE:** There may be some water in the filter. Some spilling may occur. Use a towel to wipe up any spills.

3. Take the new filter out of its packaging and remove the covers from the O-rings. Be sure the O-rings are still in place after the covers are removed.
4. With the arrow pointing to the left (toward the filter cover door's hinge), align the new filter with the filter housing and slide it into place. The filter cover door will automatically begin to close as the new filter is inserted.
5. Close the filter cover door completely in order to snap the filter into place. You may need to press hard.
6. Flush the water system. See "Water and Ice Dispensers."

## Ice Maker and Storage Bin

### Turning the Ice Maker On/Off

- To turn on the ice maker, lift open the ice maker door and lower the wire shutoff arm to the ON position.
- To manually turn off the ice maker, lift the wire shutoff arm to the OFF (arm up) position and listen for the click. Ice can still be dispensed, but no more can be made.

**NOTE:** Your ice maker has an automatic shutoff. As ice is made, the ice cubes will fill the ice storage bin, and the ice cubes will raise the wire shutoff arm to the OFF (arm up) position. Do not force the wire shutoff arm up or down.

### **REMEMBER:**

- Allow 24 hours to produce the first batch of ice. Discard the first three batches of ice produced.
- The quality of your ice will be only as good as the quality of the water supplied to your ice maker. Avoid connecting the ice maker to a softened water supply. Water softener chemicals (such as salt) can damage parts of the ice maker and lead to poor quality ice. If a softened water supply cannot be avoided, make sure the water softener is operating properly and is well maintained.
- Do not use anything sharp to break up the ice in the storage bin. This can cause damage to the ice container and the dispenser mechanism.
- Do not store anything on top of or in the ice maker or storage bin.

### Removing and Replacing the Ice Storage Bin

1. Lift and hold open the ice maker door.
2. Lift the wire shutoff arm so it clicks into the OFF (up) position. Release the ice maker door.
3. Lift up the front of the storage bin and pull it out.

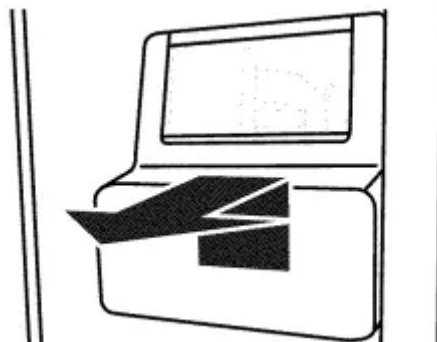

4. Replace the bin by pushing it in all the way, or the dispenser will not work.
5. To restart ice production, lift open the ice maker door and push the wire shutoff arm down to the ON position.

## REFRIGERATOR FEATURES

Your model may have some or all of these features.

### **Important information to know about glass shelves and covers:**

Do not clean glass shelves or covers with warm water when they are cold. Shelves and covers may break if exposed to sudden temperature changes or impact, such as bumping. Tempered glass is designed to shatter into many small, pebble-size pieces. This is normal. Glass shelves and covers are heavy. Use both hands when removing them to avoid dropping.

### **Refrigerator Shelves (number of shelves varies by model)**

Store similar foods together and adjust the shelves to fit different heights. This reduces the time the refrigerator door is open and saves energy.

#### **To Remove and Replace a Shelf:**

1. Pull the shelf forward to the stop. Tilt the front of the shelf up. Lift to remove from the shelf supports.
2. Replace the shelf/frame by aligning the shelf with the shelf supports. Slide the shelf onto the shelf supports. Be sure that the shelf is securely in position.

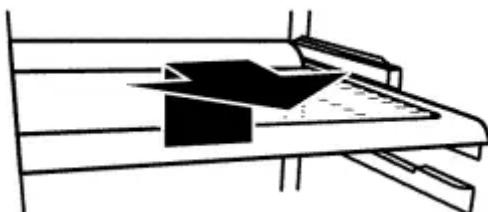

### **Deli Drawer (on some models)**

The deli drawer stores raisins, nuts, spreads, and other small items at normal refrigerator temperatures.

#### **To Remove and Replace the Deli Drawer:**

1. Remove the deli drawer by sliding it straight out to the stop. Lift the front and rear of the drawer up and out of the shelf supports. Tilt the drawer sideways to remove it from the refrigerator compartment.
2. Replace the deli drawer by sliding it back past the stop and pushing it into place.

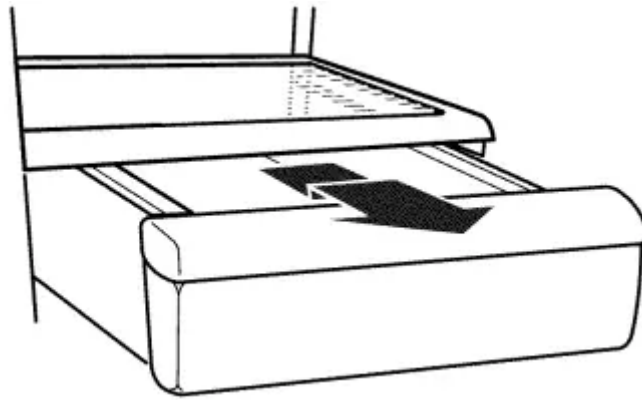

## **Convertible Vegetable/Meat Drawer, Crisper and Covers (on some models)**

### **Crisper and Convertible Vegetable/Meat Drawers**

#### **To Remove and Replace Drawers:**

1. Slide crisper or meat drawer straight out to the stop. Lift the front of drawer with one hand while supporting the bottom of drawer with the other hand and slide the drawer out the rest of the way.
2. Replace the crisper or meat drawer by sliding it back in fully past the drawer stop.

### **Crisper and Convertible Vegetable/Meat Drawer Covers**

#### **To Remove and Replace Covers:**

1. Remove the crisper and meat drawer. Press up in center of crisper glass insert until it rises above the plastic frame. Holding the crisper glass firmly, slowly slide the glass insert forward to remove. Lift crisper cover frame and remove. Repeat steps to remove the meat drawer cover.

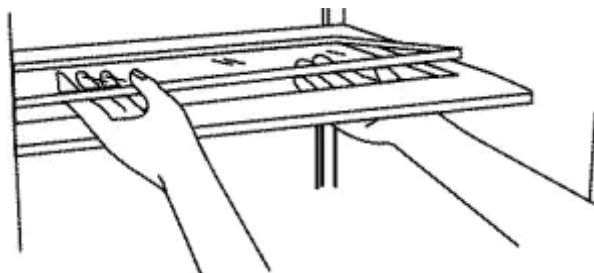

2. Replace back of meat drawer cover frame into supports or slides on side walls of the refrigerator and lower or slide the front of the cover frame into place. Slide rear of glass insert into cover frame and lower front into place. Repeat steps to replace the crisper cover.

## **Convertible Vegetable/Meat Drawer Temperature Control (on some models)**

The convertible vegetable/meat drawer can be adjusted to properly chill meats or vegetables. The air inside the pan is cooled to avoid “spot” freezing and can be set to keep meats at the National Livestock and Meat Board recommended storage temperatures of 28° to 32°F (-2° to 0°C).

**IMPORTANT:** To extend freshness, wrap meats in airtight, moisture-proof materials before storing. Always store meat as recommended.

**Adjusting the Control:**

- Move the control to the right (colder) or to the left (less cold) as desired.

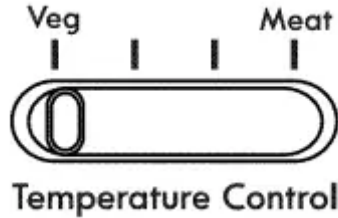

To store vegetables: Set the control to VEG (all the way to the left) to store vegetables at their optimal storage temperatures (which need to be warmer than those for meat).

**IMPORTANT:** If food starts to freeze, move the control to the left (less cold), toward the VEG setting. Remember to wait 24 hours between adjustments. Doing so gives the temperature of the food time to change.

**Meat Storage Guide**

Store most meat in original wrapping as long as it is airtight and moisture-proof. Rewrap if necessary. See the following chart for storage times. When storing meat longer than the times given, freeze the meat.

Fresh fish or shellfish.....use same day as purchased

Chicken, ground beef, variety meat (liver, etc.).....1-2 days

Cold cuts, steaks/roasts.....3-5 days

Cured meats.....7-10 days

Leftovers - Cover leftovers with plastic wrap, aluminum foil, or plastic containers with tight lids.

**Crisper Humidity Control (on some models)**

You can control the amount of humidity in the moisture-sealed crisper. Adjust the control to any setting between FRUIT [-] and VEGETABLES [+].



FRUIT [-] (open) lets moist air out of the crisper for best storage of fruits and vegetables with skins.

- Fruit: Wash, let dry and store in refrigerator in plastic bag or crisper. Do not wash or hull berries until they are ready to use. Sort and keep berries in original container in crisper, or store in a loosely closed paper bag on a refrigerator shelf.
- Vegetables with skins: Place in plastic bag or plastic container and store in crisper.



VEGETABLES [+] (closed) keeps moist air in the crisper for best storage of fresh, leafy vegetables.

- Leafy vegetables: Wash in cold water, drain and trim or tear off bruised and discolored areas. Place in plastic bag or plastic container and store in crisper.

## **FREEZER FEATURES**

Your model may have some or all of these features.

### **Frozen Food Storage Guide**

Storage times will vary according to the quality and type of food, the type of packaging or wrap used (should be airtight and moisture-proof), and the storage temperature. Ice crystals inside a sealed package are normal. This simply means that moisture in the food and air inside the package have condensed, creating ice crystals.

Put no more unfrozen food into the freezer than will freeze within 24 hours (no more than 2 to 3 lbs of food per cubic foot [907 to 1,350 g per 28 L] of freezer space). Leave enough space in the freezer for air to circulate around packages. Be certain to leave enough room for the door to close tightly.

For more information on preparing food for freezing, check a freezer guide or reliable cookbook.

### **Freezer Shelf (number of shelves varies by model)**

#### **To Remove and Replace the Shelf:**

1. Slide the shelf to one side. Tilt the shelf upward to remove the shelf from the support holes. To remove the other side from the support holes, pull the shelf upward and in the opposite direction.
2. Replace the shelf by inserting the left side of the shelf into the support holes. Lower the right side of the shelf and insert into support holes.

**NOTE:** Be sure that both sides of the shelf are positioned evenly in the shelf support holes and the shelf is secure.

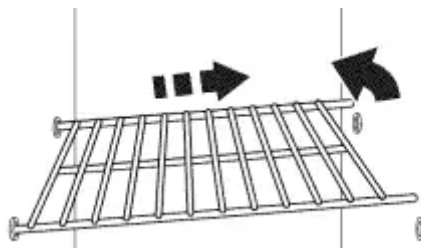

### **Freezer Bin (on some models)**

The freezer bin can be used to store bags of frozen fruits and vegetables that may slide off freezer shelves.

### To Remove and Replace the Freezer Bin:

1. Remove the bin by sliding it out to the stop. Lift the front to slide the bin out the rest of the way.

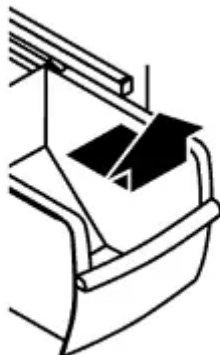

2. Replace the bin by positioning it on the rails. Lift the bin front slightly while pushing it in fully past the stops.

## DOOR FEATURES

Your model may have some or all of these features.

### Door Bins (on some models)

#### To Remove and Replace the Bins:

1. Remove the bin by lifting it and pulling it straight out.
2. Replace the bin by sliding it in above the desired supports and pushing it down until it stops.

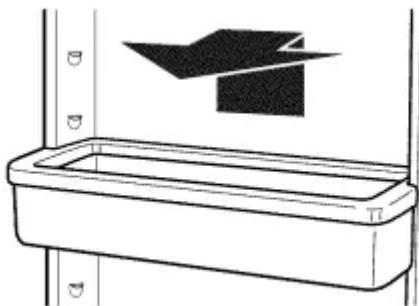

### Door Rails or Bins (on some models)

The door rails or bins may be removed for easier cleaning.

#### Snap-On Door Rails or Bins

#### To Remove and Replace the Rails or Bins:

1. Remove the rails or bins by pushing in slightly on the front of the bracket while pulling out on the inside tab. Repeat these steps for the other end of the rail or bin.

2. Replace the rails or bins by aligning the ends of the brackets with the buttons on the sides of the door liner. Firmly snap bracket onto the tabs above the shelf as shown.

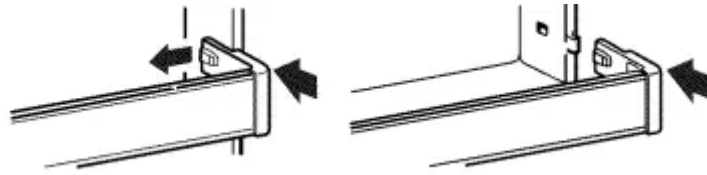

### **Drop-In Door Rails**

#### **To Remove and Replace the Rails:**

1. Remove the rails by pulling straight up on each end of the rail.
2. Replace the rails by sliding the shelf rail into the slots on the door and pushing the rail straight down until it stops.

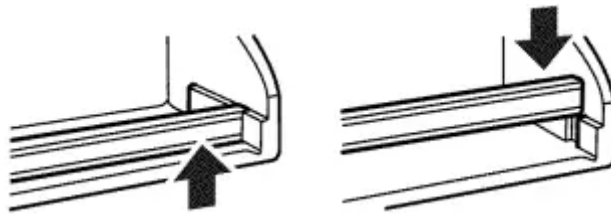

## **REFRIGERATOR CARE**

### **Cleaning**

**WARNING Explosion Hazard Use nonflammable cleaner. Failure to do so can result in death, explosion, or fire.**

Both the refrigerator and freezer sections defrost automatically. However, clean both compartments about once a month to avoid buildup of odors. Wipe up spills immediately.

#### **To Clean Your Refrigerators**

1. Unplug refrigerator or disconnect power.
  2. Remove all removable parts from inside, such as shelves, crispers, etc.
  3. Hand wash, rinse, and dry removable parts and interior surfaces thoroughly. Use a clean sponge or soft cloth and a mild detergent in warm water.
- Do not use abrasive or harsh cleaners such as window sprays, scouring cleansers, flammable fluids, cleaning waxes, concentrated detergents, bleaches or cleansers containing petroleum products on plastic parts, interior and door liners or gaskets. Do not use paper towels, scouring pads, or other harsh cleaning tools. These can scratch or damage materials.

- To help remove odors, you can wash interior walls with a mixture of warm water and baking soda (2 tbs to 1 qt [26 g to 0.95 L] of water).

4. Determine whether your refrigerator exterior is painted metal, Ultra Satin™ (stainless look) finish, brushed aluminum or stainless steel, and choose the appropriate cleaning method.

**NOTE:** Ultra Satin™ (stainless look) finish has a smooth, uniform color with a glossy finish that resists fingerprints. Stainless steel has a distinct grainy texture with variation in color that is natural to steel.

**Painted metal:** Wash exteriors with a clean sponge or soft cloth and a mild detergent in warm water. Do not use abrasive or harsh cleaners, or cleaners designed for stainless steel. Dry thoroughly with a soft cloth. Additionally, to avoid damage to painted metal exteriors, apply appliance wax (or auto paste wax) with a clean, soft cloth. Do not wax plastic parts.

**Brushed aluminum:** Wash with a clean sponge or soft cloth and a mild detergent in warm water. Do not use abrasive or harsh cleaners, or cleaners designed for stainless steel. Dry thoroughly with a soft cloth.

**Ultra Satin™ (stainless look) finish:** Wash with a clean sponge or soft cloth and a mild detergent in warm water. Do not use abrasive or harsh cleaners, or cleaners designed for stainless steel. Dry thoroughly with a soft cloth.

**Stainless steel finish:** Wash with a clean sponge or soft cloth and a mild detergent in warm water. Do not use abrasive or harsh cleaners. Dry thoroughly with a soft cloth.

- To keep your stainless steel refrigerator looking like new and to remove minor scuffs or marks, it is suggested that you use the manufacturer's approved Stainless Steel Cleaner and Polish. To order the cleaner, see "Accessories."

**IMPORTANT:** This cleaner is for stainless steel parts only!

- Do not allow the Stainless Steel Cleaner and Polish to come into contact with any plastic parts such as the trim pieces, dispenser covers or door gaskets. If unintentional contact does occur, clean plastic part with a sponge and mild detergent in warm water. Dry thoroughly with a soft cloth.

5. If your model has a touch screen display on the dispenser panel, clean the screen using a soft, lint-free cloth. Mix a mild detergent with water, then use the mixture to dampen the cloth and gently wipe the screen.

- To avoid unintentionally changing settings, make sure the refrigerator is unplugged or the power is disconnected before wiping the screen.

- Do not over-saturate the cloth. Do not spray or wipe liquids directly onto the screen. Do not use abrasive or harsh cleaners such as window sprays, scouring cleansers, flammable fluids, cleaning waxes, concentrated detergents, nail polish remover, bleaches or cleansers

containing petroleum products. Do not use paper towels, scouring pads, or other harsh cleaning tools. These can scratch or damage materials.

6. There is no need for routine condenser cleaning in normal home operating environments. If the environment is particularly greasy or dusty, or there is significant pet traffic in the home, the condenser should be cleaned every 2 to 3 months to ensure maximum efficiency.

If you need to clean the condenser:

- Remove the base grille. See “Base Grille” graphic or “Base Grille” section.
  - Use a vacuum cleaner with a soft brush to clean the grille, the open areas behind the grille and the front surface area of the condenser.
  - Replace the base grille when finished.
7. Plug in refrigerator or reconnect power.

## Lights

**NOTE:** Not all appliance bulbs will fit your refrigerator. Be sure to replace the bulb with one of the same size and shape.

- The dispenser lights are LEDs that cannot be changed.
- On some models, the interior lights are LEDs that cannot be changed.
- On some models, the interior lights require a 40-watt bulb.

1. Unplug refrigerator or disconnect power.
2. Remove light shield when applicable, as explained in the following sections.

**NOTE:** To clean the light shield, wash it with warm water and liquid detergent. Rinse and dry the shield well.

3. Remove light bulb and replace with one of the same size, shape and wattage.
4. Replace light shield when applicable, as shown.
5. Plug in refrigerator or reconnect power.

### **Crisper Lights**

- If necessary, remove the top crisper drawer for easier access to the crisper light shield. Remove the light shield by squeezing the top and bottom in toward the center and pulling the bottom tabs out of the refrigerator liner, then sliding the top tabs down and out.
- Replace the light shield by sliding the top tabs up into the slotted holes in the refrigerator liner, then snapping the bottom tabs into place. If necessary, replace the top crisper drawer.

### **Lower Freezer Light (on some models)**

- Remove the light shield by grasping the sides and squeezing in toward the center. Once the side hooks of shield are free from the freezer lining, pull down the shield.
- Replace the light shield by squeezing the sides toward the center and inserting the side hooks into the slotted holes. Once the side hooks are in place, snap the front tab into the slotted hole.

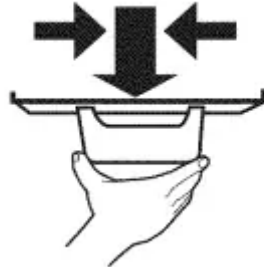

## Power Interruptions

If the power will be out for 24 hours or less, keep the door or doors closed (depending on your model) to help food stay cold and frozen.

If the power will be out for more than 24 hours, do one of the following:

- Remove all frozen food and store it in a frozen food locker.
- Place 2 lbs (907 g) of dry ice in the freezer for every cubic foot (28 L) of freezer space. This will keep the food frozen for 2 to 4 days.
- If neither a food locker nor dry ice is available, consume or can perishable food at once.

**REMEMBER:** A full freezer stays cold longer than a partially filled one. A freezer full of meat stays cold longer than a freezer full of baked goods. If you see that food contains ice crystals, it may be refrozen, although the quality and flavor may be affected. If the condition of the food is poor, dispose of it.

## Vacation and Moving Care

### If You Choose to Leave Refrigerator On While You Are Away:

1. Use up any perishables and freeze other items.
2. If your refrigerator has an automatic ice maker and is connected to the household water supply, turn off the water supply to the refrigerator. Property damage can occur if the water supply is not turned off.
3. If you have an automatic ice maker, turn off the ice maker.

**NOTE:** Depending on your model, raise the wire shutoff arm to OFF (up) position or press the switch to OFF.

4. Empty the ice bin.

### **If You Choose to Turn Refrigerator Off Before You Leave:**

1. Remove all food from the refrigerator.
2. If your refrigerator has an automatic ice maker:
  - Turn off the water supply to the ice maker at least one day ahead of time.
  - When the last load of ice drops, raise the wire shutoff arm to the OFF (up) position or move the switch to the OFF (right) setting.
3. Depending on the model, turn the Refrigerator Control to OFF or turn cooling off. See “Using the Controls” in the User Instructions, User Guide, or Use & Care Guide.
4. Clean refrigerator, wipe it, and dry well.
5. Tape rubber or wood blocks to the tops of both doors to prop them open far enough for air to get in. This stops odor and mold from building up.

### **Moving**

When you are moving your refrigerator to a new home, follow these steps to prepare it for the move.

1. If your refrigerator has an automatic ice maker:
  - Turn off the water supply to the ice maker at least one day ahead of time.
  - Disconnect the water line from the back of the refrigerator.
  - When the last load of ice drops, raise the wire shutoff arm to the OFF (up) position or move the switch to the OFF (right) setting.
2. Remove all food from the refrigerator and pack all frozen food in dry ice.
3. Empty the ice bin.
4. Depending on the model, turn the Refrigerator Control to OFF or turn cooling off. See “Using the Controls” in the User Instructions, User Guide, or Use & Care Guide.
5. Unplug refrigerator.
6. Clean, wipe, and dry thoroughly.
7. Take out all removable parts, wrap them well, and tape them together so they don't shift and rattle during the move.
8. Depending on the model, raise the front of the refrigerator so it rolls more easily OR screw in the leveling legs so they don't scrape the floor. See “Adjust the Doors” or “Door Removal, Leveling and Alignment.”
9. Tape the doors closed and tape the power cord to the back of the refrigerator.

When you get to your new home, put everything back and refer to the Installation Instructions for preparation instructions. Also, if your refrigerator has an automatic ice maker, remember to reconnect the water supply to the refrigerator.

## **PROBLEM SOLVER**

First try the solutions suggested here or visit our website to possibly avoid the cost of a service call.

### **WARNING**

Electrical Shock Hazard Plug into a grounded 3 prong outlet.

Do not remove ground prong.

Do not use an adapter.

Do not use an extension cord.

Failure to follow these instructions can result in death, fire, or electrical shock.

GENERAL OPERATION	Possible Causes and/or Recommended Solutions
<b>Refrigerator will not operate</b>	<ul style="list-style-type: none"> <li>• Not connected to an electrical supply - Plug the power cord into a grounded 3 prong outlet. Do not use an extension cord.</li> <li>• No power to the electrical outlet - Plug in a lamp to see if the outlet is working.</li> <li>• Household fuse has blown or circuit breaker has tripped - Replace the fuse or reset the circuit breaker. If the problem continues, contact a licensed electrician.</li> <li>• Control or cooling is not turned on - Turn on the refrigerator control, or turn cooling on. See “Using the Controls.”</li> <li>• New installation - Following installation, allow 24 hours for the refrigerator and freezer to cool completely.</li> </ul> <p><b>NOTE:</b> Adjusting the temperature control(s) to the coldest setting will not cool either compartment (refrigerator or freezer) more quickly.</p>
<b>Motor seems to run too much</b>	<p>■ <b>Your new refrigerator has an energy-efficient motor</b> - The refrigerator may run longer than you’re used to, because the compressor and fans operate at lower speeds that are more energy-efficient. This is normal.</p> <p><b>NOTE:</b> Your refrigerator may run even longer if the room is warm, a large load of food is added, the doors are opened often, or if a door has been left open.</p>
<b>Refrigerator seems noisy</b>	<p>The compressor in your new refrigerator regulates temperature more efficiently and uses less energy than older models. During various stages of operation, you may hear normal operating sounds that are unfamiliar.</p> <p><b>The following noises are normal:</b></p> <ul style="list-style-type: none"> <li>■ <b>Buzzing/Clicking</b> - Heard when the water valve opens and closes to dispense water or fill the ice maker. If the refrigerator is connected to a water line, this is normal. If the refrigerator is not connected to a water line, turn off the ice maker.</li> <li>■ <b>Cracking/Crashing</b> - Heard when ice is ejected from the ice maker mold.</li> <li>■ <b>Popping</b> - Heard when the inside walls contract/expand, especially during initial cooldown.</li> <li>■ <b>Pulsating/Whirring</b> - Heard when the fans/compressor adjust to optimize performance during normal operation.</li> </ul>



	<ul style="list-style-type: none"> <li>■ <b>Rattling</b> - Heard when water passes through the water line, or due to the flow of refrigerant. Rattling may also come from items placed on top of the refrigerator.</li> <li>■ <b>Water running or gurgling</b> - Heard when ice melts during the defrost cycle and water runs into the drain pan.</li> <li>■ <b>Sizzling</b> - Heard when water drips onto the heater during the defrost cycle.</li> </ul>
<p><b>Temperature is too warm</b></p>	<ul style="list-style-type: none"> <li>■ <b>New installation</b> - Following installation, allow 24 hours for the refrigerator and freezer to cool completely.</li> </ul> <p><b>NOTE:</b> Adjusting the temperature control(s) to the coldest setting will not cool either compartment (refrigerator or freezer) more quickly.</p> <ul style="list-style-type: none"> <li>■ <b>Doors are opened often or not closed completely</b> - This allows warm air to enter the refrigerator. Minimize door openings, keep the doors fully closed, and make sure both doors are properly sealed.</li> <li>■ <b>Air vents are blocked</b> - Remove items that are immediately in front of the vents.</li> <li>■ <b>Large amount of warm food recently added</b> - Allow several hours for the refrigerator to return to its normal temperature.</li> <li>■ <b>Controls are not set correctly for the surrounding conditions</b> - Adjust the controls to a colder setting. Check the temperature again in 24 hours.</li> </ul>
<p><b>Temperature is too cold</b></p>	<ul style="list-style-type: none"> <li>■ <b>Controls are not set correctly for the surrounding conditions</b> - Adjust the controls to a warmer setting. Check the temperature again in 24 hours.</li> <li>■ <b>Top refrigerator shelf is colder than lower shelves</b> - On some models, air from the freezer enters the refrigerator compartment through vents near the top refrigerator shelf. As a result, the top shelf can be slightly colder than lower shelves.</li> <li>■ <b>Air vents are blocked</b> - Remove items that are immediately in front of the vents.</li> </ul>



<p><b>Interior moisture buildup</b></p>	<p><b>NOTE:</b> Some moisture buildup is normal. Clean with a soft dry cloth.</p> <ul style="list-style-type: none"> <li>■ <b>Room is humid</b> - A humid environment contributes to moisture buildup. Only use the refrigerator in an indoor location, with as little humidity as possible.</li> <li>■ <b>Doors are opened often or not closed completely</b> - This allows humid air to enter the refrigerator. Minimize door openings, keep the doors fully closed, and make sure both doors are properly sealed.</li> </ul>
<p><b>Interior lights do not work</b></p>	<ul style="list-style-type: none"> <li>■ <b>Doors have been open for an extended period of time</b> - Close the doors to reset the lights.</li> <li>■ <b>Light bulb is loose in the socket or has burned out</b> - On models with incandescent interior light bulbs, tighten or replace the bulb. See “Lights.”</li> </ul> <p><b>NOTE:</b> On models with LED lights, call for assistance or service if the interior lights do not illuminate when either door is opened. See either the front cover or the Warranty for contact information.</p>
<p><b>Dispenser lights do not work</b></p>	<ul style="list-style-type: none"> <li>■ <b>Dispenser light is turned off</b> - On some models, if the dispenser light is set to OFF, the light will <b>(on some models)</b> turn on only when a dispenser pad/lever is pressed. If you want the dispenser light to stay on continuously, select a different setting. See “Water and Ice Dispensers.”</li> <li>■ <b>Dispenser light is set to AUTO or NIGHT LIGHT</b> - On some models, if the dispenser light is set to AUTO or NIGHT LIGHT, make sure the dispenser light sensor is not blocked. See “Water and Ice Dispensers.”</li> </ul> <p><b>NOTE:</b> On models with LED lights, call for assistance or service if the dispenser lights do not operate correctly. See either the front cover or the Warranty for contact information.</p>

**WARNING Explosion Hazard** Use nonflammable cleaner. Failure to do so can result in death, explosion, or fire.



<b>DOORS AND LEVELING</b>	<b>Possible Causes and/or Recommended Solutions</b>
<b>Doors are difficult to open</b>	<b>Gaskets are dirty or sticky</b> - Clean the gaskets and contact surfaces with mild soap and warm water. Rinse and dry with a soft cloth.
<b>Doors will not close completely</b>	<b>Door is blocked open</b> - Move food packages away from the door. Make sure all bins and shelves are in their correct positions. Make sure all packaging materials have been removed.
<b>Doors appear to be uneven</b>	<b>Doors need to be aligned, or refrigerator needs to be leveled</b> - See the leveling and door alignment instructions.
<b>Refrigerator rocks and is not stable</b>	<b>Refrigerator is not level</b> - To stabilize the refrigerator, remove the base grille and lower the leveling feet until they touch the floor. See the leveling and door alignment instructions.

**WARNING Cut Hazard** Use a sturdy glass when dispensing ice. Failure to do so can result in cuts.



ICE AND WATER	Possible Causes and/or Recommended Solutions
<p>Ice maker is not producing ice, not producing enough ice, or producing small/hollow ice</p>	<ul style="list-style-type: none"> <li>■ <b>Refrigerator is not connected to a water supply, or the water supply shutoff valve is not fully turned on</b> - Connect the refrigerator to a water supply and make sure the water shutoff valve is fully open.</li> <li>■ <b>Kink in the water source line</b> - A kink in the water line can reduce water flow, resulting in decreased ice production, small ice cubes, and/or hollow or irregularly-shaped ice. Straighten the water line.</li> <li>■ <b>Ice maker is not turned on</b> - Turn on the ice maker. See “Ice Maker and Storage Bin.”</li> <li>■ <b>New installation</b> - After connecting the refrigerator to a water source, flush the water system. (See “Water and Ice Dispensers.”) Wait 24 hours for ice production to begin. Wait 72 hours for full ice production. Discard the first three batches of ice produced.</li> <li>■ <b>Large amount of ice was recently removed</b> - Allow sufficient time for the ice maker to produce more ice.</li> <li>■ <b>Ice is jammed in the ice maker ejector arm</b> - Remove ice from the ejector arm using a plastic utensil.</li> <li>■ <b>Inadequate water pressure</b> - Verify that the household has adequate water pressure. See “Water Supply Requirements.”</li> <li>■ <b>Water filter is installed incorrectly</b> - Make sure the filter is properly installed. See “Water Filtration System.”</li> <li>■ <b>A reverse osmosis water filtration system is connected to your cold water supply</b> - This can decrease water pressure. See “Water Supply Requirements.”</li> </ul> <p><b>NOTE:</b> If questions remain regarding water pressure, contact a licensed, qualified plumber.</p>
<p>Ice dispenser will not operate properly</p>	<ul style="list-style-type: none"> <li>■ <b>Doors not closed completely</b> - Make sure both doors are firmly closed. (On some models, only the freezer door must be closed in order to operate the dispenser.)</li> <li>■ <b>New installation</b> - After connecting the refrigerator to a water source, flush the water system. (See “Water and Ice Dispensers.”) Wait 24 hours for ice production to begin. Wait 72 hours for full ice production. Discard the first three batches of ice produced.</li> </ul>



■ **Ice maker is not turned on, or ice bin is not installed correctly** -

Turn on the ice maker and make sure the ice storage bin is firmly in position. See “Ice Maker and Storage Bin.”

■ **Ice is clogged or frozen together in the ice storage bin, or ice is blocking the ice delivery chute** -

Remove or separate the clogged ice, using a plastic utensil if necessary. Clean the ice delivery chute and the bottom of the ice storage bin using a warm damp cloth, then dry both thoroughly. To avoid clogging and to maintain a fresh supply of ice, empty the storage bin and clean both the storage bin and the delivery chute every 2 weeks.

■ **Wrong ice has been added to the storage bin** - Use only ice cubes produced by the current ice maker.

■ **Dispenser is locked** - Unlock the dispenser. See “Water and Ice Dispensers.”

■ **Ice dispenser jams while dispensing crushed ice** - For models with the ice storage bin on the door, temporarily switch from crushed ice to cubed ice to clear the jam.

■ **Dispenser pad/lever has been pressed too long** - Ice will automatically stop dispensing. Wait a few minutes for the dispenser to reset, then resume dispensing. Take large amounts of ice directly from the ice bin, not through the dispenser.

■ **Water pressure to the home is not at or above 30 psi (207 kPa)** - The water pressure to the home affects the flow from the dispenser. See “Water Supply Requirements.”

■ **Water filter is clogged or incorrectly installed** - Replace filter or reinstall it correctly. See “Water Filtration System.”

**Ice or water has an off-taste, odor, or gray color**

■ **New plumbing connections** - New plumbing connections can result in off-flavored or discolored ice or water. This problem should go away over time.

■ **Ice has been stored too long** - Discard the ice and wash the ice bin. Allow 24 hours for the ice maker to produce new ice.

■ **Odor has transferred from food** - Use airtight moisture-proof packaging to store food.

■ **Use of non-recommended water supply line** - Odors and tastes can transfer from certain materials used in non-recommended water supply lines. Use only a recommended water supply line. See “Water Supply Requirements.”



	<ul style="list-style-type: none"> <li>■ <b>There are minerals (such as sulfur) in the water</b> - A water filter may need to be installed in order to remove the minerals.</li> <li>■ <b>Water filter was recently installed or replaced</b> - Gray or dark discoloration in ice or water indicates that the water filtration system needs additional flushing. See “Water and Ice Dispensers.”</li> </ul>
<p><b>Water dispenser will not operate properly</b></p>	<ul style="list-style-type: none"> <li>■ <b>Doors not closed completely</b> - Make sure both doors are firmly closed. (On some models, only the freezer door must be closed in order to operate the dispenser.)</li> <li>■ <b>Refrigerator is not connected to a water supply, or the water supply shutoff valve is not turned on</b> - Connect the refrigerator to a water supply and make sure the water shutoff valve is fully open.</li> <li>■ <b>Kink in the water source line</b> - A kink in the water line can reduce water flow to the dispenser. Straighten the water line.</li> <li>■ <b>Water pressure to the home is not at or above 30 psi (207 kPa)</b> - The water pressure to the home affects the flow from the dispenser. See “Water Supply Requirements.”</li> <li>■ <b>New installation</b> - After connecting the refrigerator to a water source, flush the water system. See “Water and Ice Dispensers.”</li> <li>■ <b>Dispenser is locked</b> - Unlock the dispenser. See “Water and Ice Dispensers.”</li> <li>■ <b>Water filter is clogged or incorrectly installed</b> - Replace filter or reinstall it correctly. See “Water Filtration System.”</li> <li>■ <b>A reverse osmosis water filtration system is connected to your cold water supply</b> - This can decrease water pressure. See “Water Supply Requirements.”</li> </ul> <p><b>NOTE:</b> If questions remain regarding water pressure, contact a licensed, qualified plumber.</p>
<p><b>Water Is leaking or dripping from the dispenser</b></p>	<p><b>NOTE:</b> After dispensing, a few additional drops of water are normal.</p> <ul style="list-style-type: none"> <li>■ <b>Glass was not held under the dispenser long enough</b> - Hold the glass under the dispenser for 2 to 3 seconds after releasing the dispenser pad/lever.</li> <li>■ <b>New installation, or water filter was recently installed or replaced</b> - Air in the water lines causes the water dispenser to drip. Flush the water system to remove the air in the water lines. See “Water and Ice Dispensers.”</li> </ul>



	<ul style="list-style-type: none"> <li>■ <b>Residual ice in the dispenser chute is melting</b> - Make sure the ice chute is free of ice shavings or pieces.</li> </ul>
<p><b>Water is leaking from the back of the refrigerator</b></p>	<ul style="list-style-type: none"> <li>■ <b>Water line connections are not fully tightened</b> - Make sure all connections are firmly tightened. See “Connect Water Supply.”</li> </ul>
<p><b>Water from the dispenser is not cool enough (on some models)</b></p>	<p><b>NOTE:</b> Water from the dispenser is chilled to <b>50°F (10°C)</b>.</p> <ul style="list-style-type: none"> <li>■ <b>New installation</b> - Allow 24 hours after installation for the water supply to cool completely.</li> <li>■ <b>Recently dispensed a large amount of water</b> - Allow 24 hours for the new water supply to cool completely.</li> <li>■ <b>Water has not been recently dispensed</b> - The first glass of water may not be cool. Discard the first glass of water dispensed.</li> <li>■ <b>Refrigerator is not connected to a cold water pipe</b> - Make sure the refrigerator is connected to a cold water pipe. See “Water Supply Requirements.”</li> </ul>

**Warning**

This content is compiled from multiple sources and is provided for reference purposes only. It may not be complete or fully applicable to all situations. If you are unable to resolve your issue, please contact the product manufacturer or an authorized service provider for official support.

