

## PRODUCT FEATURES

### Powerful Suction

Suction power of this product is strong enough to ensure that even tiny dust on the floor will be cleaned thoroughly!

### User Friendly Design

Operation is greatly simplified.

One-key start/clean:

Just press the CLEAN button to start robot

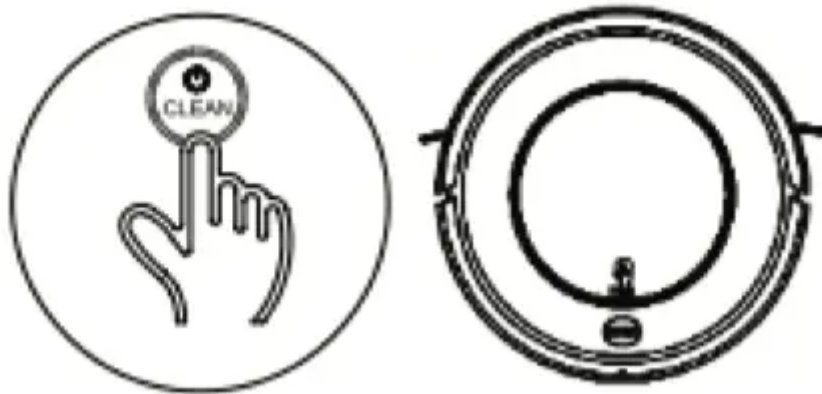

### Washable Dust Bin and Primary Filter

Dust bin and primary filter can be washed with water after emptying the bin.

- a. Re-install the HEPA and primary filter after they're fully dry.
- b. HEPA and primary filter can be replaced when needed.
- c. Wash primary filter after 15~30 days of use. Maximum life span for HEPA and filter is 24 months.
- d. Do not bake the filters under intense sunshine.



## Cleaning Modes

### 1. Auto Cleaning Mode

The robot will clean a room automatically and adjust its cleaning behavior based on specific situation.

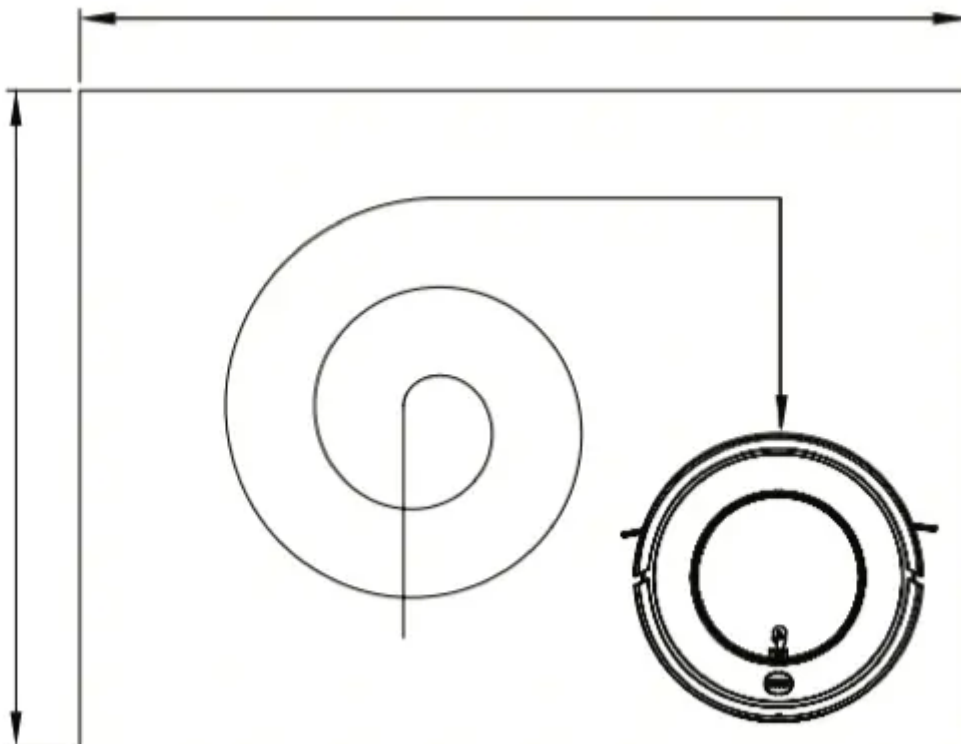

### 2. Spot Cleaning Mode

The robot will clean intensively in a spiral way with more power, suitable for an open area with much dust.

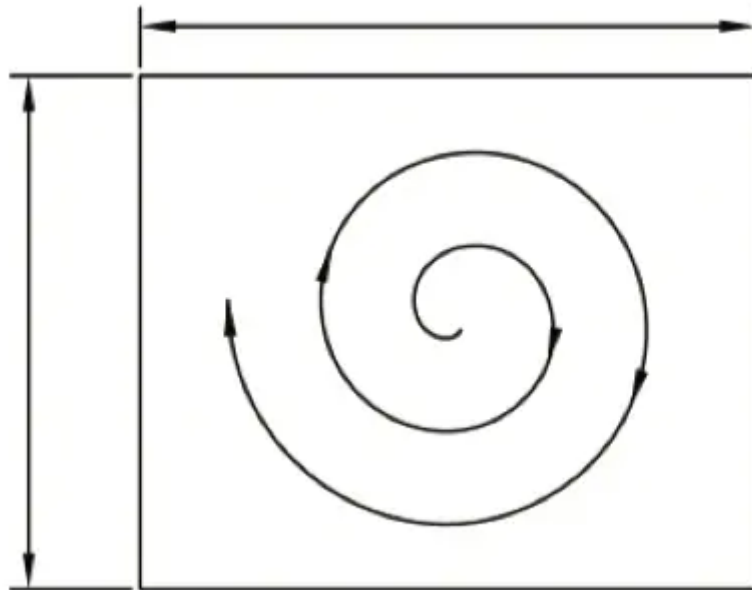

### 3. Edge Cleaning Mode

In this mode the robot will clean along the wall or obstacles.

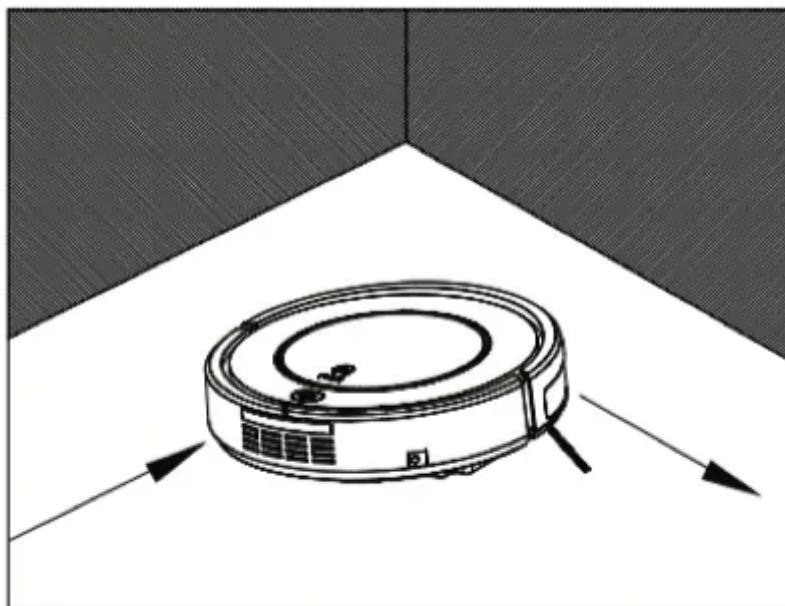

### 4. Scheduling Mode



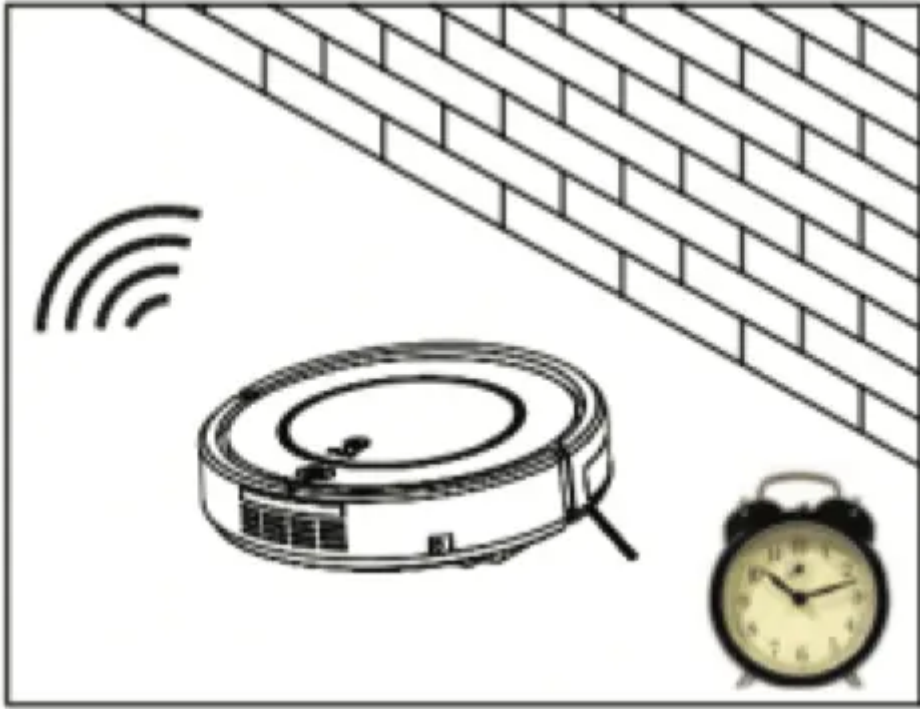





After being scheduled, the robot will leave charging station and start working at scheduled time.

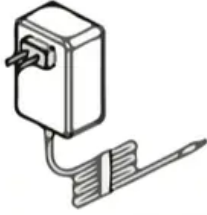

# PRODUCT COMPONENTS

## Main Body and Accessories

No.	Description	Quantity
1.	Main Body	1
2	Charging Station	1
3	Power Adapter	1
4	Remote Controller (battery not included).	1
5	Mopping Cloth*1 and Mopping Plate*1	1+1
6	HEPA Filter	1
7	Cleaning Brush	1
8	Side Brushes *2	2
9	User Manual	1

1 	2 	3 
4 	5 	6 
7 	8 	9 



# Main Body Diagram

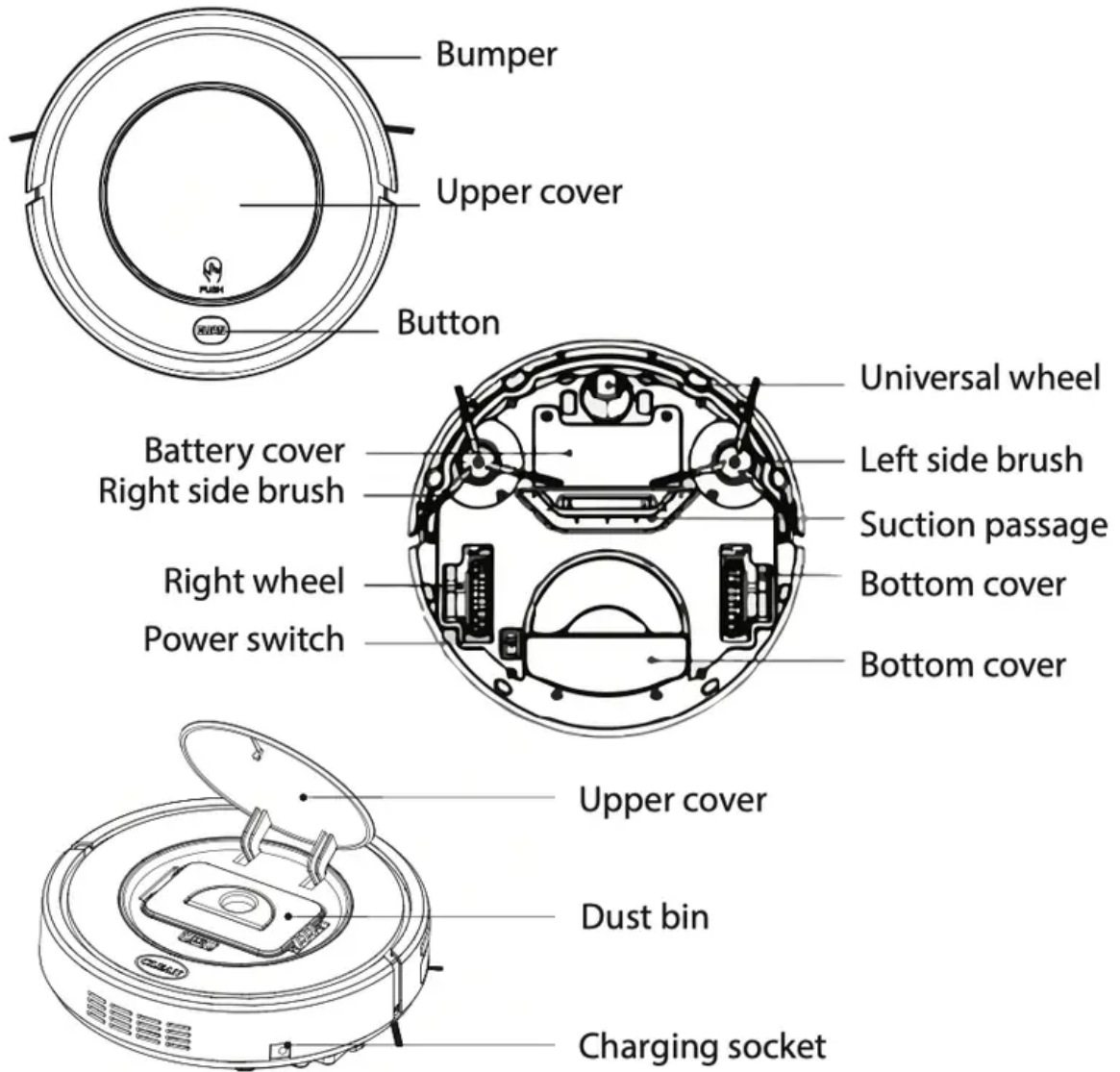

## Dust Bin

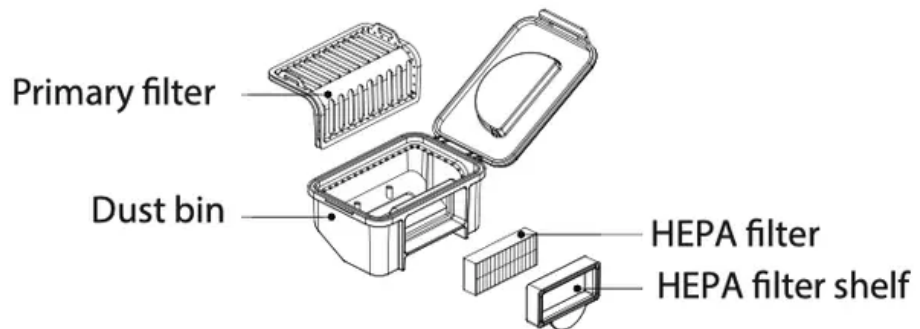

## Charging Station

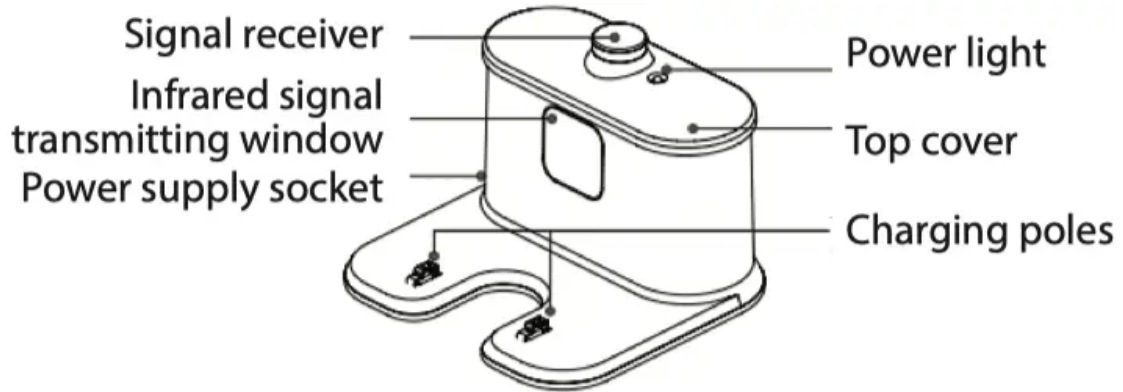

## Remote Controller

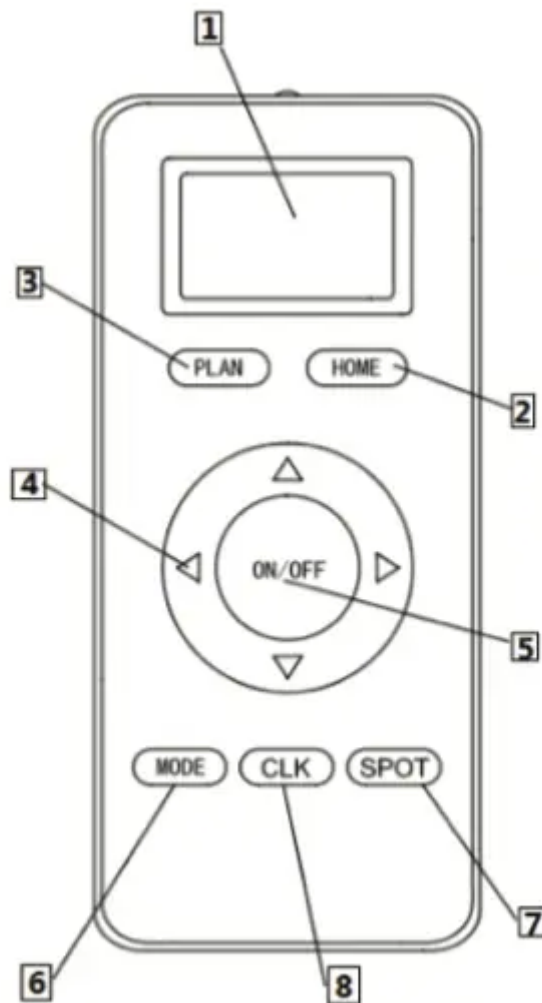

1. Digital display
2. Auto charging
3. Scheduling button
4. Direction buttons

5. ON/OFF
6. Mode selection button
7. Spot cleaning button
8. Time setting button

- A. Install two AAA type batteries into the remote controller before use.
- B. Remove the batteries if the remote controller will be left unused for a long period.
- C. If you use the remote controller near the charging station, the robot may not recognize the command and may not work.

## Display Panel

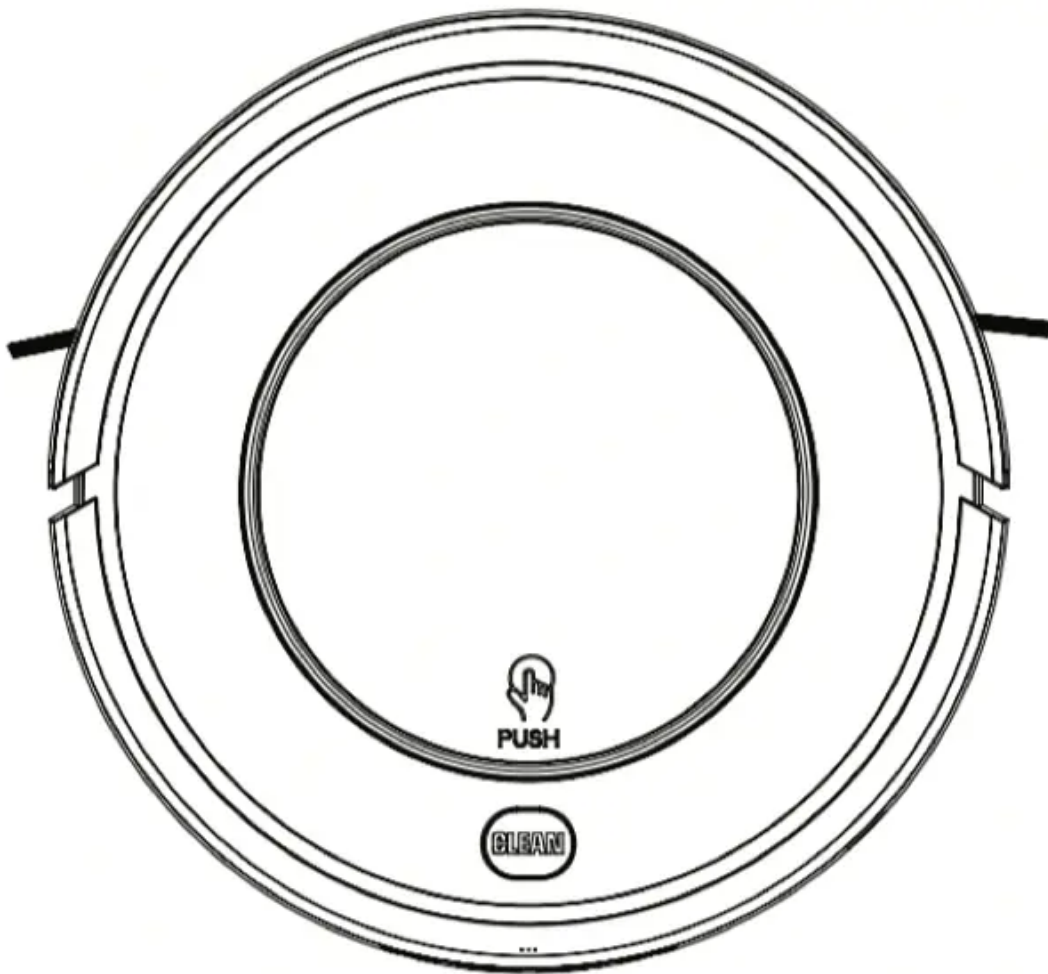

- A. Switch on robot, press CLEAN button or ON/OFF on remote, robot will beep twice and enter in standby status, the indicator will flash blue.
- B. Press CLEAN button or ON/OFF on remote again, robot will beep three times and the indicator will flash blue quickly, if its function is normal, robot will start cleaning, and the indicator stay blue during cleaning.

- C. If the robot is malfunctioned, its indicator will be in different status with different color (please see details in troubleshooting).
- D. The indicator will display quick red flash when the robot is low power.
- E. While charging (by charging station or adapter), indicator will flash red. After fully charged, robot will beep five times and indicator turns blue.
- F. When the robot is successfully scheduled, the indicator will keep on pink for 2 seconds and beep once, then return to its original status.
- G. Cancel scheduling, indicator will flash pink for 2 seconds and beep twice, then return to its original status.
- H. Press PLAN button on remote to check whether robot has already scheduled. If yes, the indicator will keep on pink for 2 seconds and beep once, then return to its original status. If no schedule, the indicator will have no change but beep once.

## PRODUCT OPERATION

### Battery Charging

#### 1. Charging station placement

Place charging station against the wall and remove obstacles within 1 meter at two sides and 2 meters ahead. As shown in the right figure.

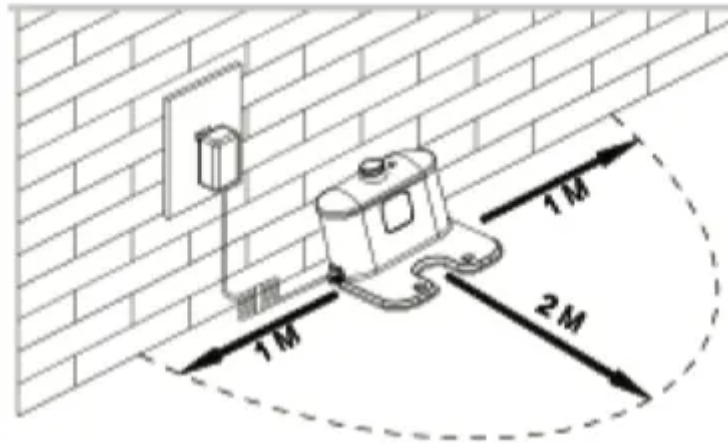

2. If the robot has been shut down, power on it by turning on the power switch at the right side of the robot before charging.

3. Charge the robot in either of following way as shown:

- a. Plug the adapter into the robot and plug the other end into the power socket, as shown in Fig A.
- b. Press "HOME" button on remote controller to direct the robot to charging station for recharging, as shown in Fig B.

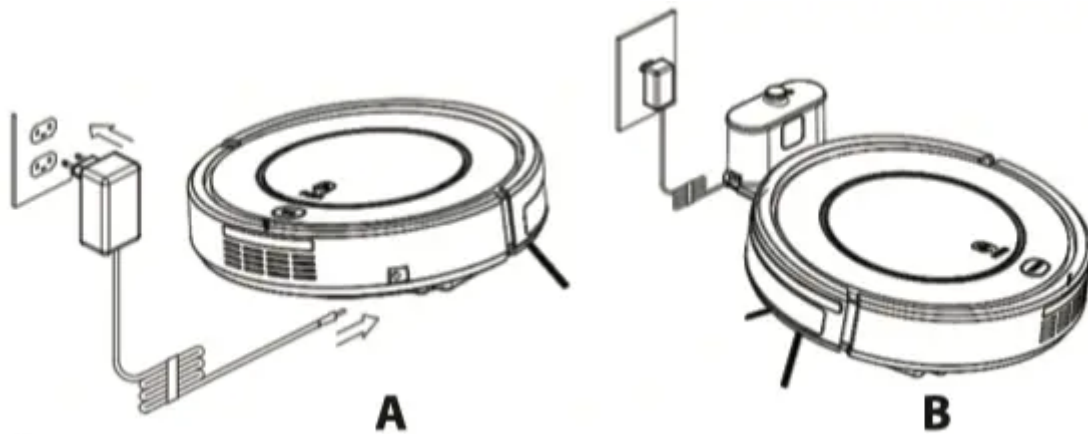

**Note:**

- a. Make sure the power switch of robot is turned on while charging. Otherwise, CLEAN indicator will flash red quickly and beep a long time. (If power switch is turned off, the schedule setting will be lost.)
- b. When robot is being charged, CLEAN indicator will flash red gradually.
- c. After fully charged, the robot will beep five times. (Every charge should take no more than 5 hours).
- d. In the working status, the robot will return to charging station automatically when battery power is low.

**Tips to extend battery life:**

- a. Before first use, charge the robot for 12 hours.
- b. Charge the robot as soon as battery power is low.
- c. The robot will return to charging station automatically when it finishes cleaning or battery power is low.
- d. If the robot is not to be used for a long time, fully charge the battery, turn the power off, remove it from robot and store it in a cool, dry place.
- e. If the robot is not to be used for more than 3 months, charge the robot for 12 hours, turn the power off, and store it in a cool, dry place.

**STARTING UP / STANDBY / SLEEP MODE / POWER OFF**

**1. STARTING UP**

A. Power on the robot by turning on the power switch at the right side of machine. Press CLEAN button or ON/OFF on remote, robot will beep twice and enter in standby status, CLEAN indicator light will flash blue gradually.



B. In standby, press CLEAN button on main body or ON/OFF on remote to start cleaning. The robot will beep three times, and the LED indicator will flash blue quickly, if its function is normal, robot will start cleaning, LED indicator will stay blue during cleaning.

**Note:**

1. If robot is in Sleep mode, long press CLEAN button for 3 seconds on main body or ON/OFF on remote to wake up the robot to standby status firstly.
2. If robot goes into deep sleep (powered off after 15 minutes not working), long press CLEAN button for 3 seconds to wake it up to standby status firstly.

## **2. STANDBY**

The robot is waiting for the user's operation with power switched on. Through one of the following methods, you can change into standby mode:

- A. During the cleaning process, press CLEAN button on main body to enter standby mode.
- B. During the cleaning process, press the ON/OFF on remote controller to pause the robot.

**Note:** When robot is paused, user can perform new operation.

## **3. SLEEP MODE**

Turn robot into sleep mode, its display indicator will be in dark (robot is not powered off);

- A. Robot will automatically enter into sleep mode and beep once if no command is received for more than 60 seconds.
- B. Long press CLEAN button on the main body for 3 seconds, robot will beep once and enter into sleep mode.
- C. You can long press CLEAN button for 3 seconds on main body or ON/OFF on remote to wake up the robot to standby status.

## **4. POWER OFF**

By either of the following methods, you can power off the robot:





- A. In standby mode, turn off the power switch at the right side of machine.
- B. In sleep mode, the robot will automatically power off if there is no operation within 15 minutes, it can only be woken up by CLEAN button on robot, long press CLEAN button on main body for 3 seconds to wake up the robot to standby status.

**Note:**

If the robot is not in use for a long time, please turn the power switch off.

## **SCHEDULING**

You can schedule the robot to make it start cleaning automatically at a certain time everyday.

1. The robot can only be set when it's in standby or charging on the docking station. (If the robot is in cleaning, pause it before scheduling. If the robot is in sleep mode, long press CLEAN button on main body or ON/OFF on remote controller to wake it up. If the robot is in deep sleep-power off, long press CLEAN button on main body to wake it up.)
2. Before scheduling, please set the real time for remote: Long press CLK button on remote for 3 seconds to enter hour-setting,  icon will flash, and the left two numbers will flash on remote display, press upward / downward button to increase or decrease hour. Press left button can turn to minute-setting, the right two numbers will flash on remote display, press upward / downward button to increase or decrease minutes. Continue to press left button, will enter into week day setting, from SUN. To SAT. At last, press CLK once to confirm the real time setting,  icon stays on.
3. How to schedule: After real time setting, point the remote controller to the robot signal receiver (robot must be in standby or charging on the docking station, long press PLAN button on remote for 3 seconds to enter hour- scheduling setting, the left two numbers will flash on remote display, press upward / downward button to increase or decrease hour(0-23). Press left button can turn to minute-scheduling setting, the right two numbers will flash on remote display, press upward / downward button to increase or cancel every half an hour. Press ON/OFF button on remote to confirm the scheduling,  icon will stay on the remote display, and the CLEAN indicator on robot will stay pink for 2 seconds and beep once, means robot is successfully scheduled.
4. How to cancel scheduling: Point the remote controller to the robot signal receiver(robot must be in standby or charging on the docking station), long press PLAN button on remote for 3 seconds to enter hour- scheduling setting, set the time to 00:00, press ON/OFF button on remote to confirm the canceling. The  icon will disappear, CLEAN indicator on robot flash pink for 2 seconds and beep twice, means robot scheduling has been canceled successfully. You can long press PLAN button on remote to revert to main panel.
5. When robot is in standby or charging on the docking station, points the remote controller to the robot signal receiver, user can short press PLAN button to check whether robot has already scheduled. If yes, there is an  icon and a scheduling time display on remote, CLEAN indicator on robot will stay pink for 2 seconds and beep once. If not, there is 00:00 on remote display only, CLEAN indicator will have no change but robot beeps twice.

**Note:**

- A. The robot will work at the scheduled time everyday if schedule is not canceled.
- B. All scheduling will be canceled if you switch off / power off the robot (If no operation on robot for 1 minute, it will turn to sleep mode. If no operation for 15 minutes, it will turn to deep sleep and power off, scheduling will be canceled.) So, if you want to keep scheduling when

you're not at home, do not switch off power button of robot and charging station, and make sure robot can return back to the charging station when it is low power or completing cleaning.

C. If robot is charged by adapter directly (not by charging station), robot won't accept scheduling setting.

## Cleaning Modes

### 1.1 Random Cleaning (mode 2)

In this mode, the robot will clean a room and adjust its cleaning behavior automatically according to the environment.

**Note:** In standby mode, press ON/OFF button on remote controller or CLEAN button on robot to start random cleaning.

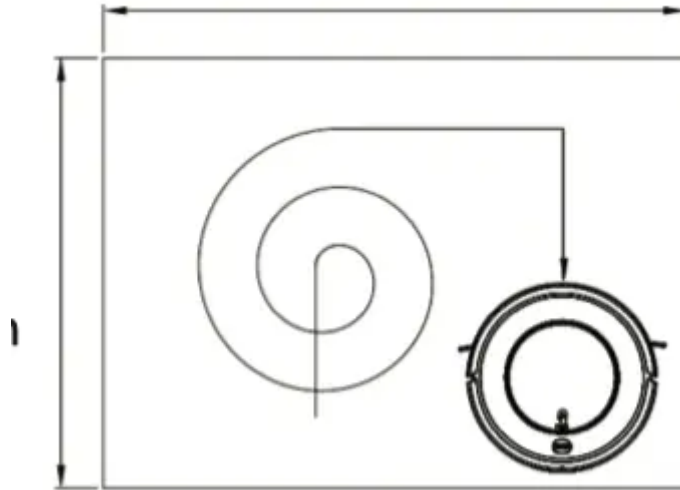

### 1.2 Spot Cleaning

This mode works with more power, suits for an open area with much dust.

**Note:** Press SPOT on the remote to start spot cleaning.

A. When robot is in standby, press SPOT, robot will take the starting point as the center, turn Outward in a spiral way, rotate for half and three turns (within 30 seconds) then stop.

B. During cleaning, press SPOT, robot will enter into 10s-30s spot cleaning then turn to other cleaning mode.

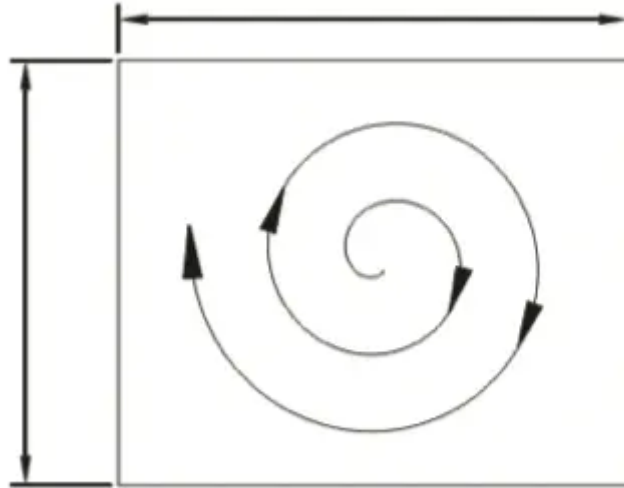

### 1.3 Spiral Cleaning (mode 1)

In this mode, robot takes the starting point as the center, then turn outward in a spiral way, this mode is suitable for an open area.

**Note:** Press MODE on the remote controller to select spiral mode.

### 1.4 Edge Cleaning (mode 3)

In this mode, robot will clean along the wall or obstacles.

**Note:**

- A. Switch on the robot, press MODE on the remote controller and select edge mode.
- B. Under edge cleaning mode, the robot will do cleaning along the obstacle by its side brushes.

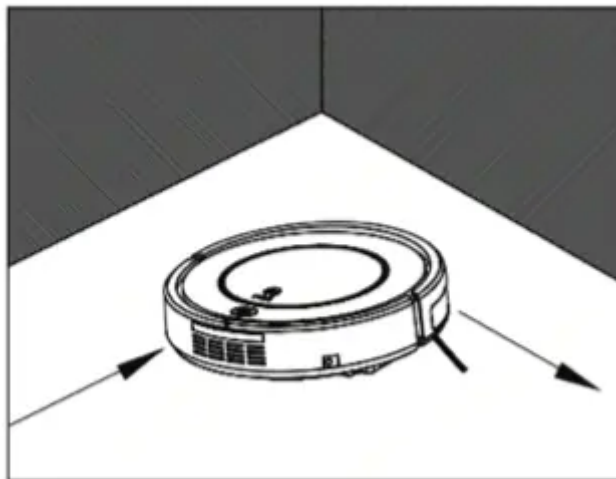

### 1.5 Zigzag Cleaning (mode 4)

The robot will automatically go into Zigzag cleaning when it detected it's in an open area or the environment with less obstacles. This mode will be more efficient and can avoid repeated cleaning.





A. Press PUSH to open the cover.

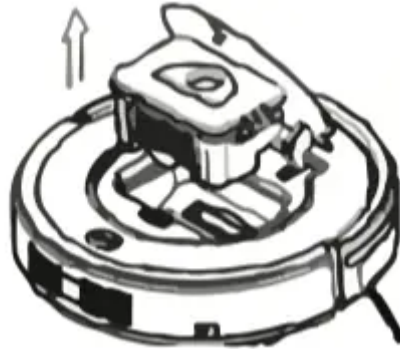

B. Take out dust bin



C. Take out HEPA.

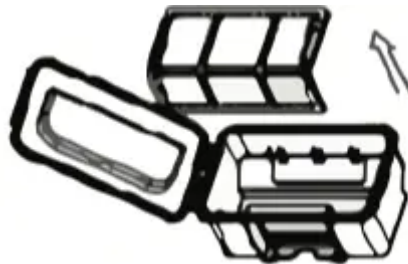

D. Open dust bin cover, take out primary filter.



E. Empty dust bin.



F. Wash dust bin and primary filter under tap water.



G. Clean HEPA filter with brush, avoid washing it under water

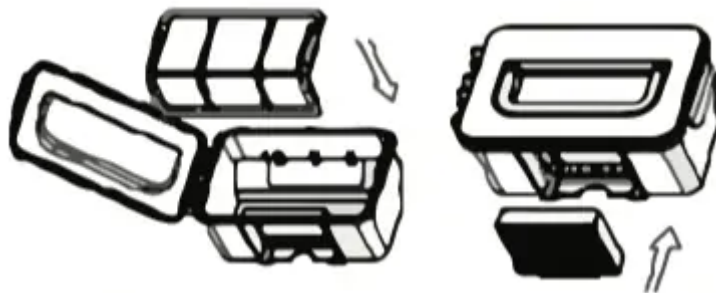

H. Install primary filter and HEPA back into the dust bin.

**Note:**

- a. Wash primary filter after 15~30 days of use.
- b. Re-install the HEPA and primary filter after they're fully dry.
- c. HEPA and primary filter could be replaced when needed.

d. Do not bake the filters under intense sunshine.

### 3. Cleaning Sensors and Wheels

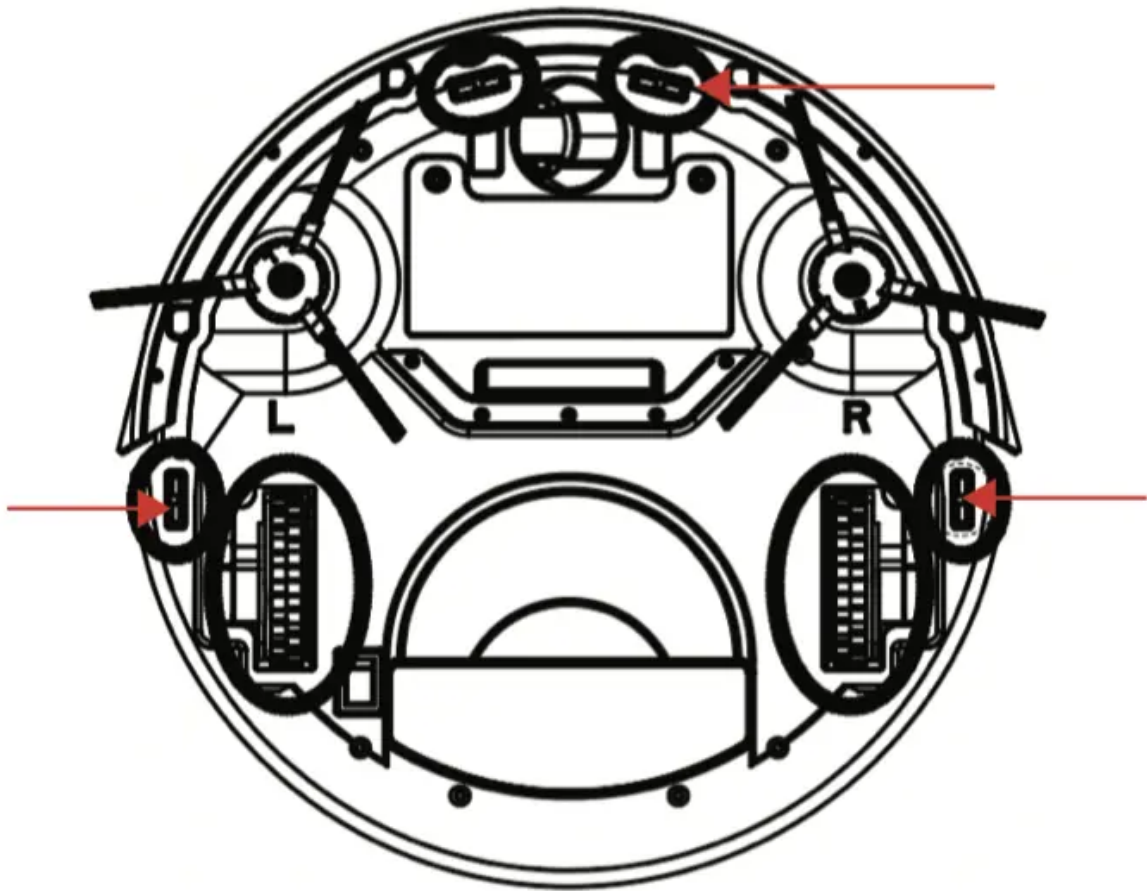

Slightly wipe all sensors and wheels, as marked in above figure, with soft cloth or tool.

### 4. Cleaning Charging Poles

Cleaning the charging poles as marked in below figure, with soft cloth or tool.

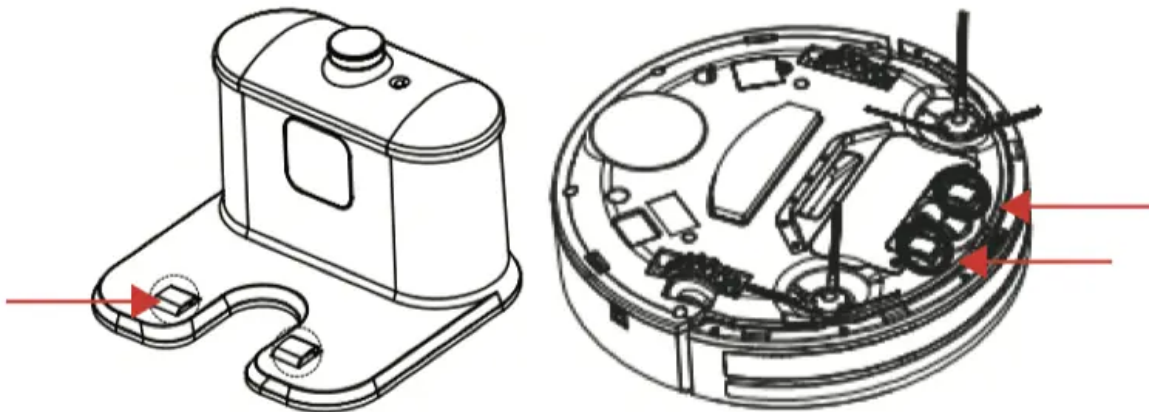

## 5. Cleaning Suction Passage

Cleaning the suction passage, as marked in below figure, with soft cloth or tool.

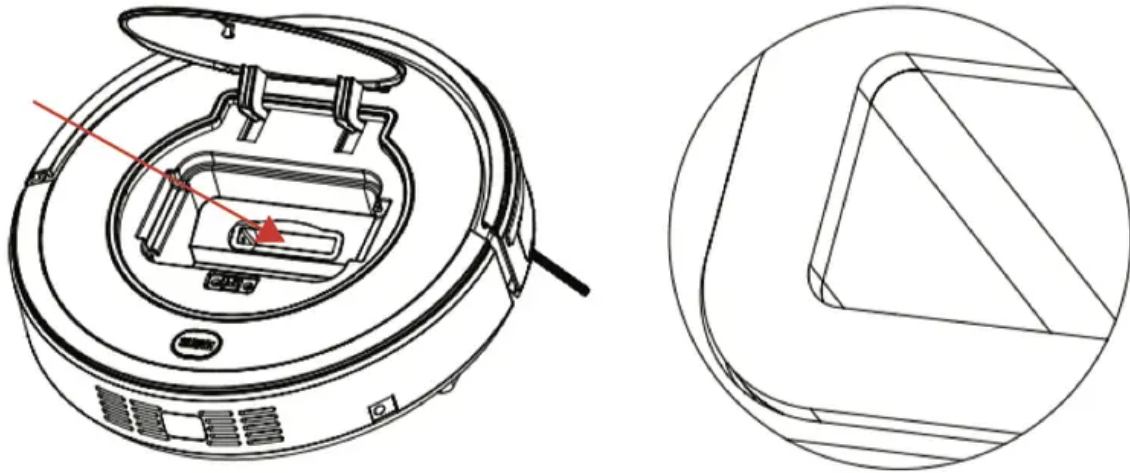

**Note:** Pay attention and avoid wetting the sensors.

## 6. Mopping Cloth Usage

A. Stick mopping cloth on mop plate fix them at the bottom of the robot, as shown in right figure.

B. When the mopping cloth is dirty, please wash and clean it. You can change a new one if needed.

**Note:** Do not clean the appliance under water.

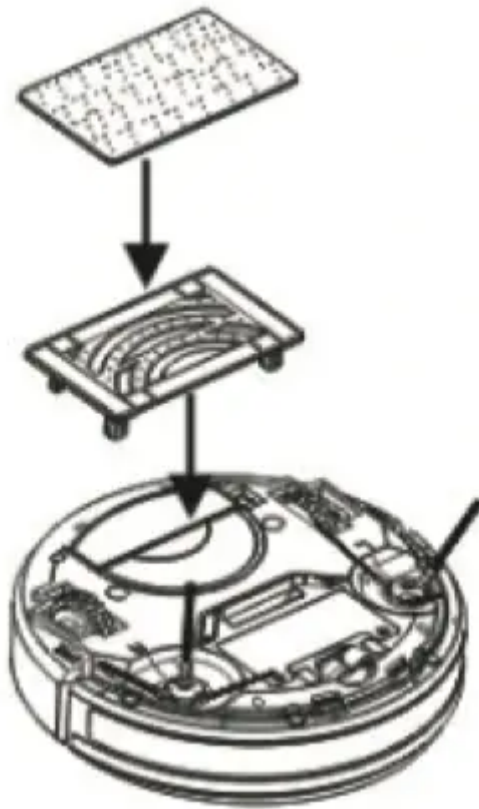

## TROUBLESHOOTING

Problem	Possible Cause	Solution
<b>Robot suddenly stops cleaning and indicator stays blue.</b>	Robot was picked up (sensors detect cliff or wheel off the ground).	Put the robot on the solid floor and re-start the robot.
<b>Place the robot on ground, turn on the robot, its indicator is in blue ( without charging).</b>	Cliff sensor fault.	1. Clean cliff sensor. 2. If solutions given above doesn't work, send it to the seller for repair.
<b>Robot does not change direction when it comes up against obstacle.</b>	Bumper sensor fault.	Check the sensor to see if it is covered by any object.
<b>During charging, LED indicator flashes red quickly and robot beeps.</b>	Power switch of robot might not turned on.	Switch on the robot.
<b>LED indicator flashes red quickly.</b>	Battery low power.	Fully charge the battery.
<b>Blue LED flashes once, Red LED flashes once.</b>	Side brush get stuck.	Put robot on flat surface and clean side brush.

**Note:**

If all solutions given above don't work for you, please take actions below:

1. Re-set the robot by switching on the power button at the right side of main body.
2. If reset action doesn't work, please send the robot to seller for repairing.

**Note:**

Particular specifications are subjected to change without prior notice. Don't forget to register your unit to activate your 1 year warranty!

**Warning**



This content is compiled from multiple sources and is provided for reference purposes only. It may not be complete or fully applicable to all situations. If you are unable to resolve your issue, please contact the product manufacturer or an authorized service provider for official support.

---

Document generated by [ManualsFile](#)

