

Getting started

Features

- **The Google Assistant™ on Android TV™**

Press the Google Assistant button on your remote to do more on your TV with your voice. Ask Google to search for the latest blockbuster, stream shows, or open multiplayer games. Have it dim the lights by connecting smart home devices. Manage tasks and see your calendar. Or ask it questions and see the answers on your TV.

- **Google Play**

Google Play is your entertainment unbound. It brings together all of the entertainment you love and helps you explore it in new ways, anytime, anywhere. We've brought the magic of Google to music, movies, TV, books, magazines, apps and games, so you get more from your content every day.

- **DTV / Analog TV / CATV**

You can use your remote to select channels which are broadcast in digital format and conventional analog format. Also, cable and satellite subscribers can access their TV channels.

- **Information display**

You can display on the TV screen the title, contents (DTV only) and other information on the current program.

- **Autoprogram**

This unit automatically scans and memorizes channels available in your area, eliminating difficult setup procedures.

- **Parental controls**

This feature allows you to block children's access to inappropriate programs.

- **Closed caption decoder**

Built-in closed caption decoder displays text for closed caption supported programs.

- **MTS / SAP tuner**

Audio can be selected from the remote.

- **Auto standby**

If there is no input signal and no operation for 15 minutes, the unit will go into standby mode automatically.

- **Sleep timer**

You can set the unit to go into standby mode after a specific amount of time.

- **Choices for on-screen language**

Select your on-screen language: English, Spanish or French.

- **Stereo sound function**

- **Various adjustments for picture and sound**

Customizes picture quality suitable for your room and sets your sound preference.

- **HDMI control**

HDMI control allows your other HDMI link devices to be controlled by the HDMI cable connected to your TV.

- **HDMI input**

- **HDMI-DVI input**

If your video device has a DVI output jack, use an HDMI-DVI conversion cable to connect the unit.

- **AV input**

Audio and video input from an external device.

- **Digital audio output**

- **Headphone audio output**

Headphone 3.5 mm stereo jack for personal listening.

Included accessories

Quick start guide



Safety instruction /
Limited warranty



Caution sheet



TV base and screws *



Remote and Batteries
(AAA, 1.5 V x 2)

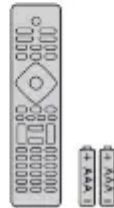

Note(s)

- If you lose the screws, please purchase the above-mentioned phillips head screws at your local store.
- If you need to replace these accessories, please refer to the part name or No. with the illustrations and call our toll free customer support line found on the cover of this user manual.

When using a universal remote to operate this unit.

- Make sure the component code on your universal remote is set to our brand. Refer to the instruction book accompanying your remote for more details.
- We do not guarantee 100% interoperability with all universal remote.

Symbols used in this user manual

The following is the description for the symbols used in this user manual. Description refers to:

Digital TV operation

Cable / NTSC (Analog) TV operation

- If neither symbol appears, the operation is applicable to both.

Unpacking

Cover a table top with a cloth or blanket to avoid damage to the TV screen. Hold both sides of the TV set to place on the table.

1. Open the top flaps of the box.



2. Remove all accessories.

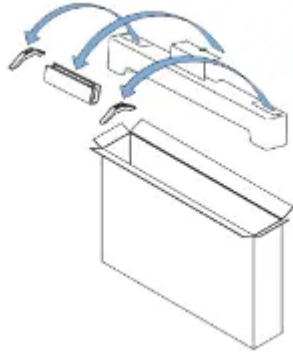

3.

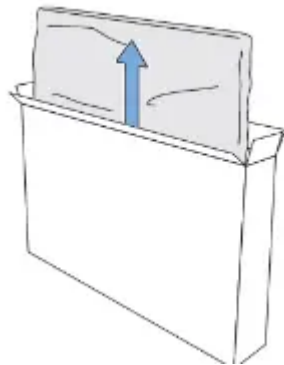

4.



Note(s)

- Carefully lay the TV set, with the screen side down, on the table.

Installing the stands

1. Remove the tape on the bottom of the TV set and the plastic bag.

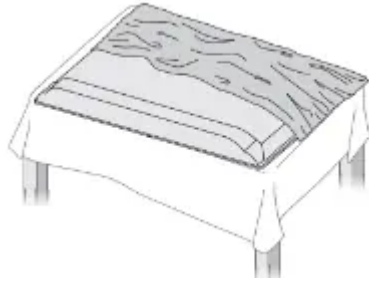

2. Fasten the stand to the TV with 4 screws.

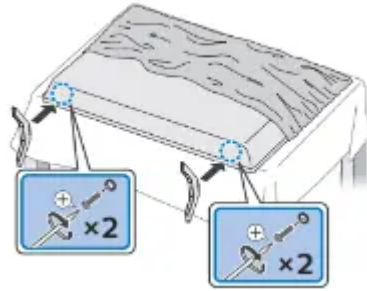

Note(s)

- While fastening the screws, hold the stand to prevent it from falling.

3. Both stands should now be securely fastened.



Note(s)

- A wide open space is recommended for assembly.
- A Phillips-head screwdriver is required to fasten the stands to the TV set.
- When attaching the stand, ensure that all screws are tightly fastened. If the stand is not properly attached, it could cause the unit to fall, resulting in injuries as well as damage to the unit.
- To remove the stand from this unit, unscrew the phillips-head screws by reversing the procedure. Be careful not to drop the stand when you remove it.

Lifting the TV set

Carefully lift the TV set as shown in the illustration and place it onto a stable, level surface.

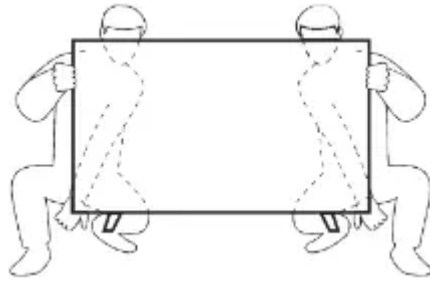

Installing the Batteries

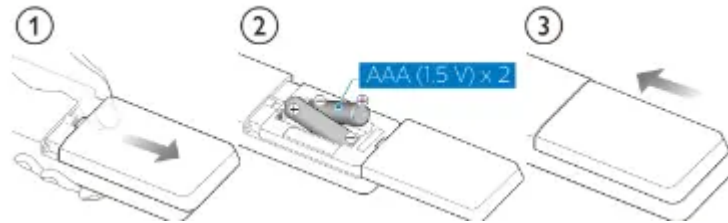

1. Open the battery cover by firmly sliding down.
2. Insert 2 AAA (1.5 V) batteries matching the polarity indicated inside battery compartment of the remote.
3. Slide the cover back into position.

! Caution(s)

- For remote that have the battery cover on the front, please take care to slide the cover down BEFORE lifting it off to prevent accidentally breaking the tabs that hold it in place.

≡ Note(s)

- Remove the batteries if not using the remote for an extended period of time.

Remote

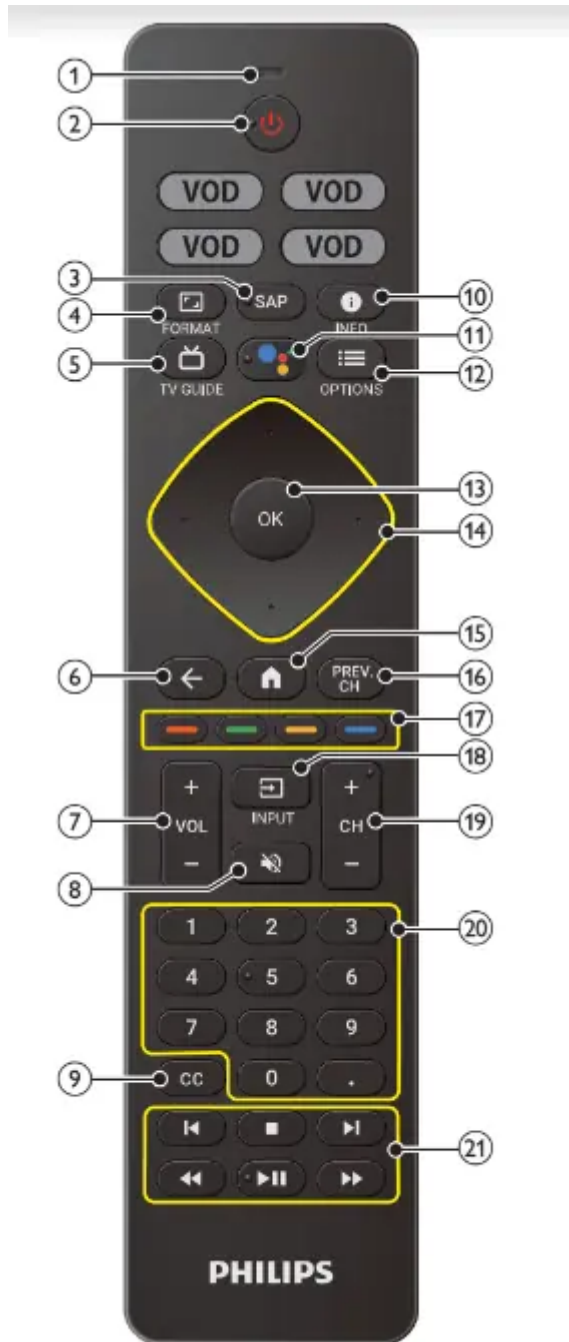

1. Microphone

2. (POWER)

Turn the TV on/off into Quick Start Standby. Holding the button for 1 second or more will put the TV into Low Power Standby.

3. SAP

Selects audio mode (MONO / STEREO / SAP) / audio language.

4. (FORMAT)

Adjusts the picture size on the TV screen.

5. (TV GUIDE)

Access to the Electronic Program Guide (EPG).

6. ← (BACK)

Returns to the previous menu screen.

7. VOL + / -

Adjusts the volume.

8. 🚫 (MUTE)

Turns the sound on and off.

9. CC

Selects closed caption settings.

10. ⓘ (INFO)

Displays input and resolution information.

11. Google Assistant

Press the Google Assistant button on your remote to ask Google.

12. ☰ (OPTIONS)

Displays a list of menu options applicable to the active screen.

13. OK

Press to decide the command of setting when the Home menu is displayed.

14. ▲▼◀▶ (NAVIGATION buttons)

Moves the cursor, selects the on-screen menu items.

15. 🏠 (HOME)

Access to your apps, Live TV, input devices, settings, and the Google Play Store.

16. PREV.CH

Direct access to the Live TV channels.

Displays the last selected terminal or channel.

17. COLOR buttons

Works as direct access to user specified net apps.

18. 📺 (INPUT)

Change input source.

Select and change access to the attached devices such as Blu-ray player, gaming consoles, or cable box.

19. CH + / -

Selects a channel.

20. 0 - 9 (NUMBER buttons)

Used to enter a channel / program number.

- **(DOT)** : Use with 0-9 to select digital channels. For example, to enter 2.1, press

21. EasyLink buttons

⏮ / ⏭: Skips backward or forward chapters, titles or tracks on a disc.

■: Stops the disc playback.

◀◀ / ▶▶: Searches backward or forward through the disc.

▶ ||: Starts, pauses or resumes playback.

Control panel

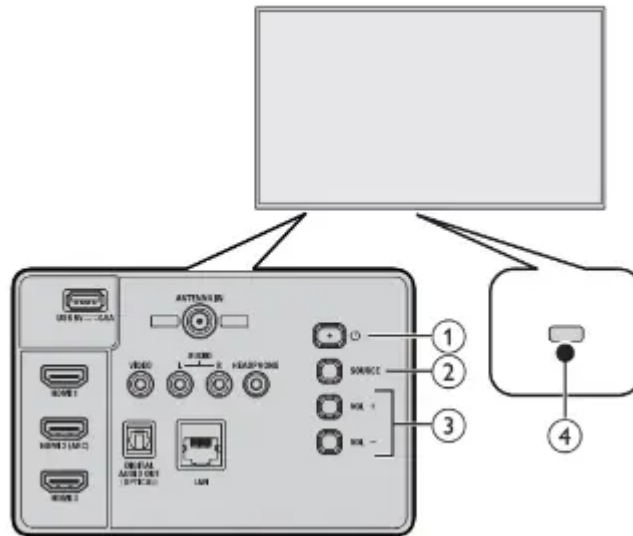

1. (POWER)

Turns the TV on or switches the TV into standby mode.

Turns the TV on and off of standby.

2. SOURCE

Selects connected devices.

3. VOL + / -

Adjusts the volume.

VOL + : Volume up

VOL - : Volume down

4. Remote sensor

Receives IR signal from remote.

Terminals

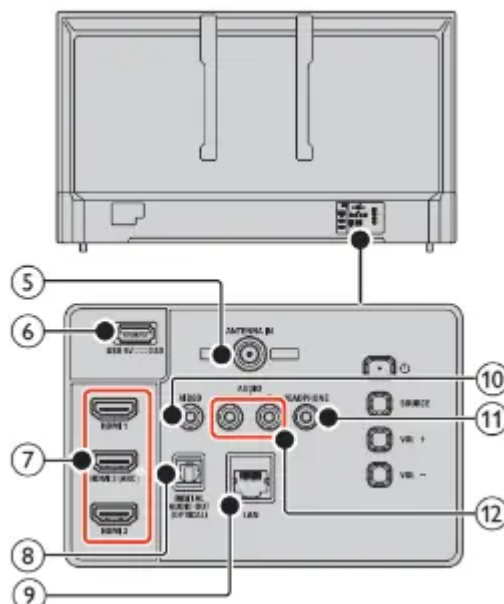

5. 75 ohm Cable / Antenna connection

Signal input from an antenna or Cable / Satellite set-top boxes.

6. USB terminal

Data input from USB memory stick only.

7. HDMI input jack(s)

Digital audio and video input from high definition digital devices such as DVD / Blu-ray Disc™ players, Soundbar / cable / satellite set-top boxes, PC's, etc.

- HDMI-DVI / Analog audio (L/R) jacks signal
- Composite video / Analog audio (L/R) jacks signal
- PC connection / Analog audio (L/R) jacks signal with stereo mini 3.5 mm plug audio cable on PC
- For HDMI 2 only : In addition to normal HDMI functionality, it outputs TV audio to an HDMI-ARC compliant device, such as a soundbar and home theater system.

8. Digital audio output (Optical) jack

Digital audio (SPDIF) output to home theaters and other digital audio systems.

9. Ethernet port

For internet connection using an Ethernet cable with an RJ-45 connector.

10. Composite video (VIDEO) input jack

Connect composite analog video signal.

11. Headphone audio output jack

Headphone 3.5 mm stereo jack for personal listening.

12. Analog audio (L/R) input jacks

Connect analog audio signals from;

- HDMI-DVI / Analog audio (L/R) jacks signal
- Composite video / Analog audio (L/R) jacks signal
- PC connection / Analog audio (L/R) jacks signal with stereo mini 3.5 mm plug audio cable on PC



Note(s)

- This TV has a USB port which is designed for connecting peripheral devices, such as a keyboard or mouse. While you may find that a particular keyboard or mouse works to some extent, we cannot guarantee full functionality. You will not damage the TV in any way by trying various keyboards or mice, but the performance of that device may be limited.

Connecting antenna or cable / satellite / IPTV set-top box

Be sure your antenna or another device is connected properly before plugging in the AC power cord.

If connecting to an antenna through an RF cable

Any DTV programs that are broadcast in your area can be received for free through an antenna connection.

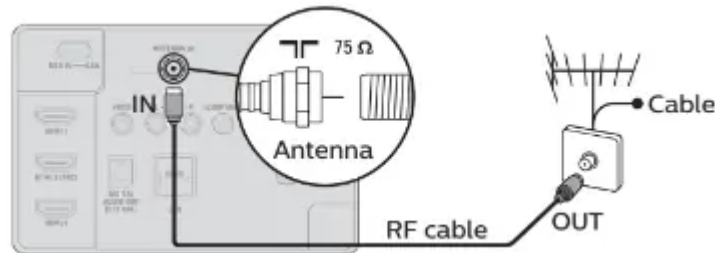

If connecting cable / satellite / IPTV set-top box using an RF cable

If the TV is connected to a cable / satellite set-top box via a coaxial connection, set the TV to channel 3/4 or the channel specified by the service provider.

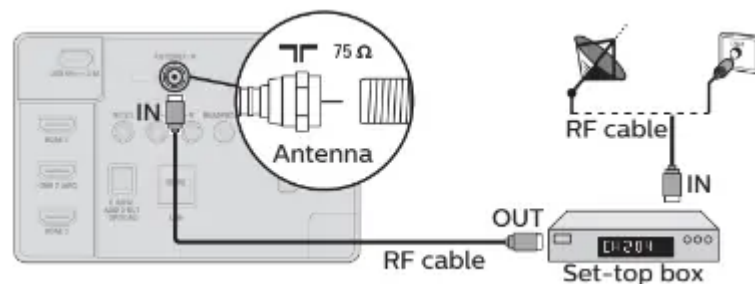

If connecting cable / satellite / IPTV set-top box using an HDMI cable

If the TV is connected to a cable / satellite set-top box via an HDMI cable, make sure you select the correct source by using  (INPUT).

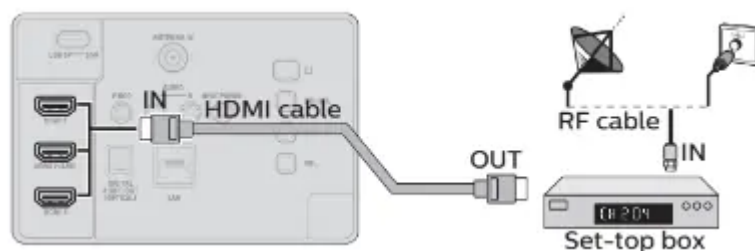

Connecting a cable / satellite / IPTV set-top box, Blu-ray Disc™ / DVD recorder via composite connectors and analog audio

Do not place your recorder too close to the screen because some recorders can be susceptible to harmful interference from the TV.

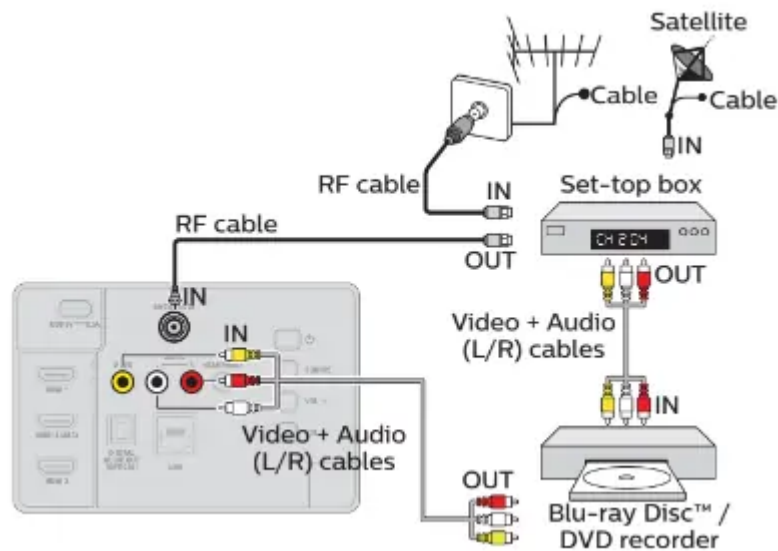

Note(s)

- Depending on your antenna system, you may need different types of combiners (mixers) or separators (splitters) for HDTV signal. The minimum RF bandpass on these devices is 2,000 MHz or 2 GHz.
- For your safety and to avoid damage to this unit, please unplug the RF coaxial cable from the antenna input jack before moving the unit.
- If you did use an antenna to receive analog TV, it should also work for DTV reception. Outdoor or attic antennas will be more effective than a set-top box or inside antenna.
- To turn on your reception source easily between antenna and cable, install an antenna selector.
- If you are not receiving a signal from your cable service, contact the cable provider.

Plugging in the AC power cord

Make sure that the AC power cord must be plugged to an AC outlet after all the necessary connections are made.

Caution(s)

- Connect the analog audio signal cables from the external device to the analog audio L/R input jacks.
- If you have an amplifier, connect the HDMI cable to the HDMI input via your amplifier.

Note(s)

- Each time you plug in the AC power cord, no operations will be performed for several seconds. This is not a malfunction.

No included cables are used with these connections:

- Please purchase the necessary cables at your local store.

Before you connect the AC power cord:

Be sure other devices are connected properly before plugging in the AC power cord.

Selecting your connection quality

HDMI - Highest quality

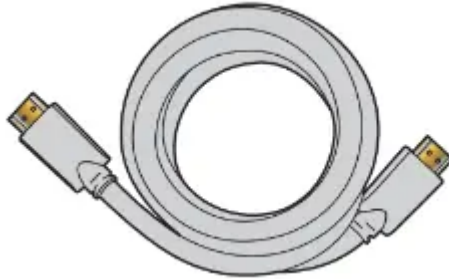

Supports high-definition digital signals and gives highest picture and sound quality. Video and audio signals are combined in one cable. You must use HDMI for full high-definition video and to enable HDMI control (HDMI CEC).



Note(s)

- Philips HDMI supports HDCP (High-bandwidth Digital Contents Protection). HDCP is a form of digital rights management that protects high-definition content in Blu-ray Disc™ or DVDs.
- The HDMI-ARC connector on the TV features HDMI-ARC functionality. This allows output of TV audio to an HDMI-ARC-compliant device.

Composite - Basic quality



For analog connections. Composite video / Audio analog cable usually combine a yellow video cable with red / white audio (L/R) cables.

Connecting your devices

HDMI digital connection

HDMI connection offers the highest picture quality.

HDMI (High-Definition Multimedia Interface) transports high- definition digital video and multi-channel digital audio through a single cable.

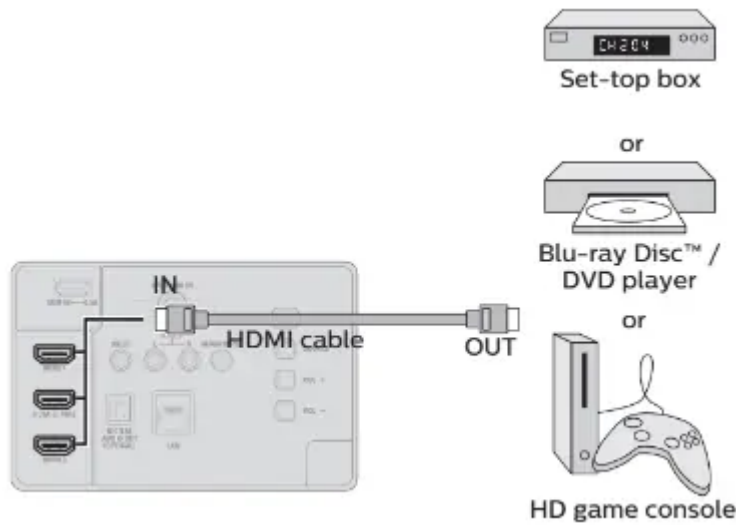

Note(s)

- If there are issues with picture/color and/or sound when connecting an external device using the HDMI port, please try switching the **HDMI EDID Version. (Refer to HDMI EDID Version → p. 15)**
- Some HDMI cables and devices may not be compatible with the TV due to different HDMI specifications.
- Use an HDMI cable with the HDMI logo (a certified HDMI cable). High speed HDMI cable is recommended for the better compatibility.
- The unit accepts 480i / 480p / 720p / 1080i, 1080p, 2160p 24/30/60 Hz of video signals, 32 kHz / 44.1 kHz and 48 kHz of audio signals.
- This unit accepts LPCM, AC-3, DD+ audio signal.
- This unit accepts only signals in compliance with CTA-861-G.

HDMI-DVI connection

This unit can be connected to a device that has a DVI terminal. Use an HDMI-DVI conversion cable for this connection and it requires audio cable for analog audio signal as well.

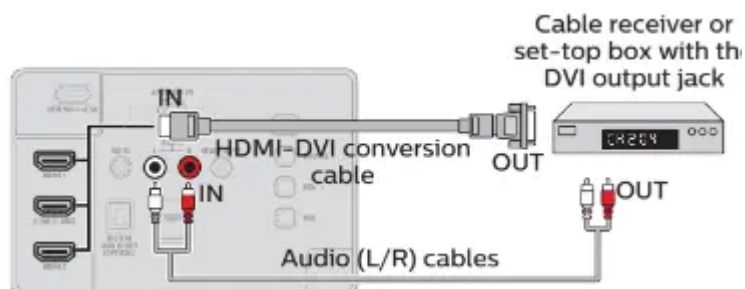

Note(s)

- Some HDMI cables and devices may not be compatible with the TV due to different HDMI specifications.
- Use an HDMI cable with the HDMI logo (a certified HDMI cable). High speed HDMI cable is recommended for the better compatibility.
- The unit accepts 480p, 720p, 1080p and 2160p video signals.
- When connecting with HDMI-DVI, the operation is maximum 2160p@30 Hz.
- HDMI-DVI connection requires separate audio connections as well and the audio signals are output as analog (L/R) audio.
- DVI does not display 480i image which is not in compliance with CTA-861-G.

HDMI-ARC connection

HDMI-ARC allows you to use HDMI control to output TV audio directly to a connected audio device, without the need for an additional digital audio cable.

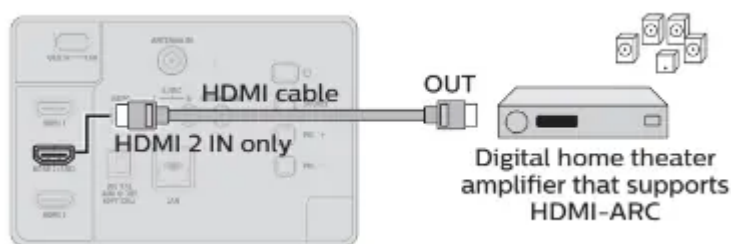



Note(s)

- The HDMI 2 connector is HDMI Audio Return Channel (ARC) compliant. Use it to output digital audio to an HDMI home theater system.
- Be sure that the device is HDMI CEC and ARC compliant and that the TV is connected to the device using an HDMI cable attached to HDMI-ARC connectors.

HDMI EDID Version

If there are issues with picture/color and/or sound when connecting an external device using the HDMI port, please try switching the HDMI mode following the instructions below.

1. Press  (**INPUT**) to switch input device list.
2. Press  (**OPTIONS**) on your remote and navigate to Settings and press OK.
3. Select **Device Preferences** and press **OK**.
4. Select **Inputs** and press **OK**.
5. Select **HDMI EDID Version** and press **OK**.

Note(s)

- EDID 1.4 is used for legacy devices that can output in 2K or 4K @30 Hz.

- EDID 2.0 is used for modern devices that can output 4K @ 60 Hz and 4K with HDR 10.

Digital audio output connection

If you connect this unit to an external digital audio device, you can enjoy multi-channel audio like 5.1ch digital broadcasting sound.

Use a digital audio optical cable to connect the unit to external digital audio devices.

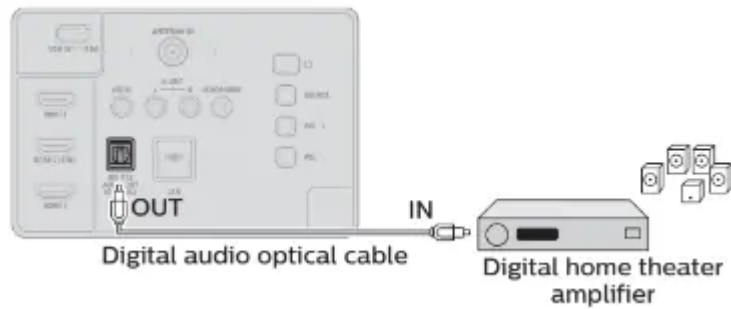

Composite analog video connection

Composite analog video connection offers standard picture quality for video devices connected to the unit.

If you connect to the unit's composite video (VIDEO) input jack, connect audio cables to the audio (L/R) input jacks. When the audio is monaural, then only connect to the audio L input jack.

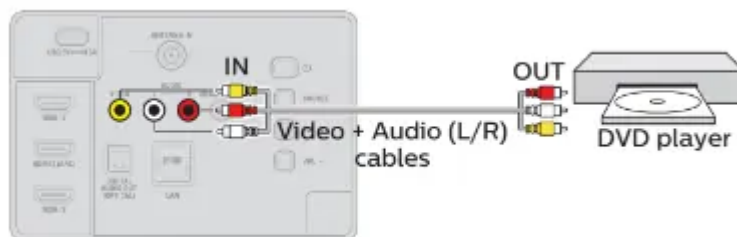

Connecting the TV to the internet using an Ethernet cable

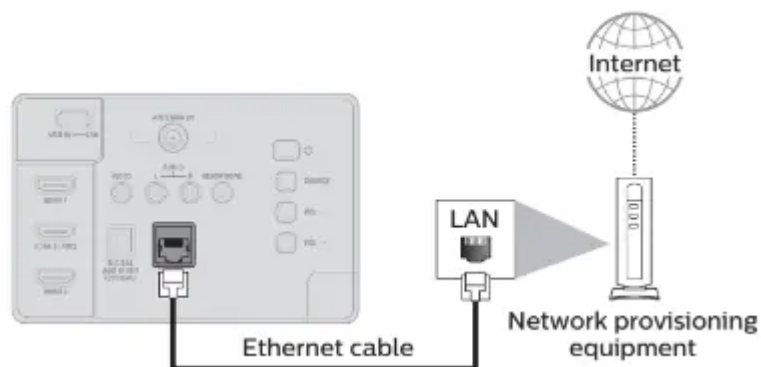

Note(s)

- Please purchase shielded Ethernet cables at your local store and use them when you connect to network equipment.
- After connecting an Ethernet cable, set up necessary network settings. **Network & Internet** → **p. 23**
- Do not insert any cable other than an Ethernet cable to the Ethernet port to avoid damaging the unit.
- If your telecommunications equipment (modem, etc.) does not have broadband router functions, connect a broadband router.
- If your telecommunications equipment (modem, etc.) has broadband router functions but there is no vacant port, then add a hub.
- For a broadband router, use a router which supports 10BASE-T / 100BASE-TX.
- Do not connect your PC directly to the Ethernet port of this unit.

Connecting the TV to the internet using a wireless LAN

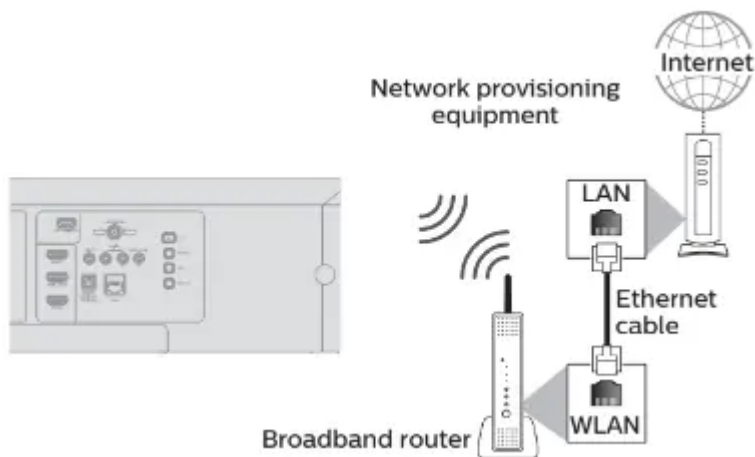

Note(s)

- After you make the wireless connection, set up the necessary network settings **Network & Internet** → **p. 23**
- Use a wireless LAN Access Point (AP) (e.g. broadband wireless router) which supports IEEE 802.11 a/b/g/n/ac. (n is recommended for stable operation of the wireless network.)
- This unit does not support Ad-hoc mode.
- Other radio devices or obstacles may cause interference to the wireless network connection.

Use your TV

Switching on your TV and putting it in standby mode

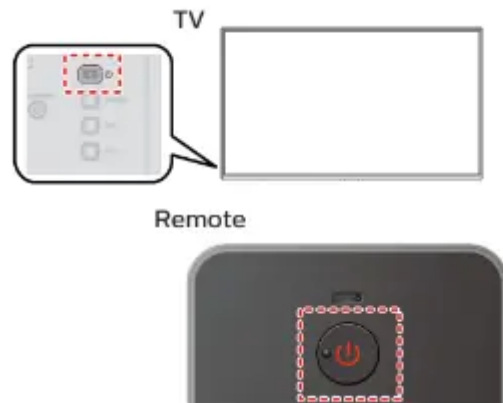

Turns the TV on and off of standby.

- Press **⏻ (POWER)** on the TV or the remote, then TV will go to suspend standby.
- Press and hold **⏻ (POWER)** on the TV or the remote, then TV will go to standby mode completely.

Note(s)

- Energy consumption contributes to air and water pollution. When the AC power cord is plugged in, your TV consumes energy with a very low standby power consumption.

Adjusting volume

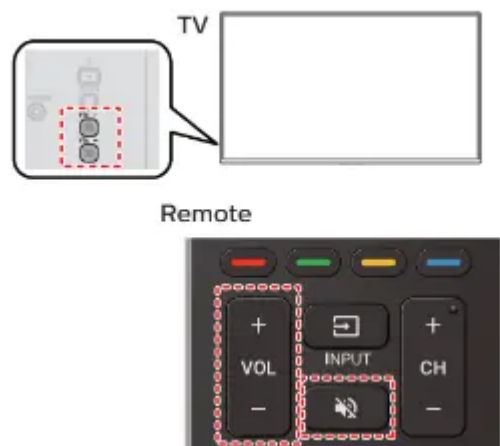

To decrease or increase volume

- Press **VOL + / -** on the TV or the remote.

VOL + : Volume up

VOL - : Volume down



Press **INPUT** and use **▲▼** to select the set-top box or the connected device and wait a few seconds till the picture appears.

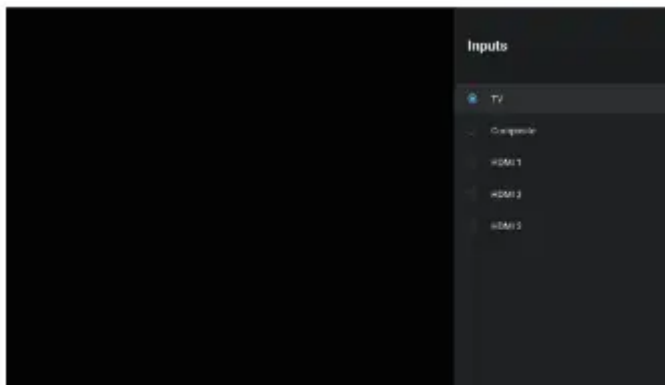

Use the remote of the set-top box or the connected device to select channels.

Access the Home menu

1. Press **HOME**.



Guide to Home menu

From the Android TV home screen, you can easily access movies, TV shows, music, apps, input devices, settings, and more.

To go back to the home screen at any time, press **HOME** on your remote.

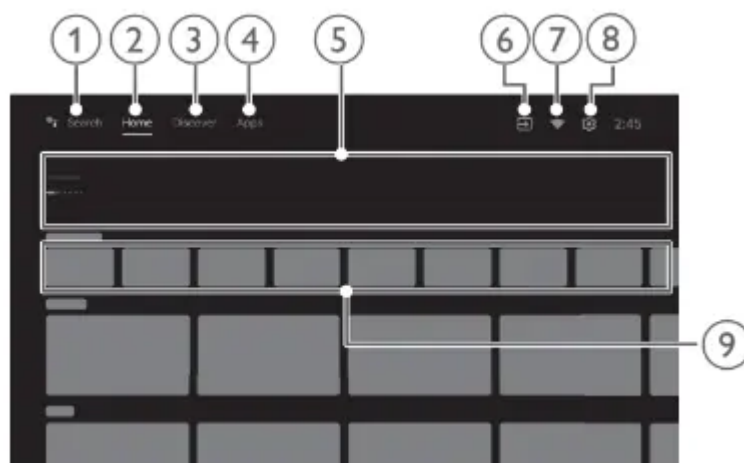

1. Google Assistant : With the Google Assistant, quickly access entertainment, control smart devices, get answer on screen, and more using your voice.

2. Home screen tab

3. Discover tab : Recommendations are shown by topic or theme. Recommendations are based on watch history, interests and new trends.

4. Apps tab : Apps gallery which pre-installed or you installed. You must sign in with a Google account to visit and download apps from the Google Play store.

5. Highlights : You can find suggestions of movies and shows to watch which are handpicked by Google Play's entertainment experts or sponsored by media partners.

6. Inputs : Toggle inputs between your favorite source devices and built-in RF tuner.

7. Network condition : Display the network status and open network settings if selected.

8. Settings : Configure your television settings and connect to wireless devices.

9. How to organize your favorite apps

Select the application and long press **OK** on your remote. To move, Select **Move** in the list, and press **OK**. Use **◀▶** to move left or right. Press **OK**. To delete, **Select** Remove from favorites in the list, and press **OK**.

Apps

You can download the apps.

1. Press **🏠 (HOME)** and use **▲▼◀▶** to select **Apps tab**, then press **OK**.

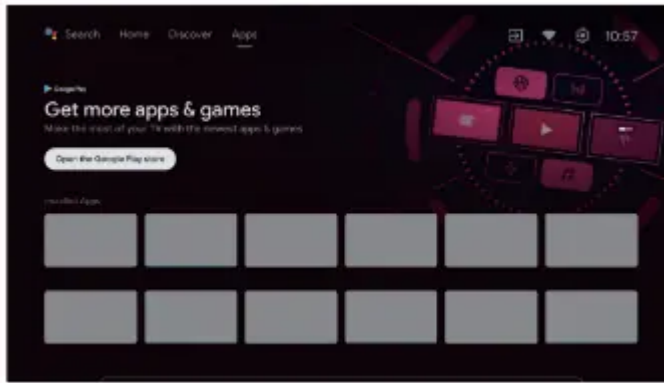

2. Select **Open the Google Play store** to open the Google Play Store apps.
3. Search for the app or type of app you want to install.
4. Select the app.
5. Select install.

Google Assistant

Press the Google Assistant button on your remote to do more on your TV with your voice. Ask Google to search for the latest blockbuster, stream shows, or open multiplayer games. Have it dim the lights by connecting smart home devices. Manage tasks and see your calendar. Or ask it questions and see the answers on your TV. To enjoy all the benefits of Google Assistant, an internet connection and Google account is required.

How to use Google Assistant with your remote

To use Google Assistant on your remote, make sure that the remote is connected via Bluetooth to the television. To check this, go to **Settings > Remotes & accessories** on your TV.

If the remote is not connected, hold down the Volume (-) and Google Assistant button together for 3 seconds and select “Add accessory” in the menu.



You can start a conversation by simply pressing the Google Assistant button on your remote to ask Google a question or say a command. When activated by button, the Google Assistant dialog bar will appear at the bottom of your television screen.

Microphone



1. Activating the Google Assistant on the home screen will launch a Google Query.

- Activating the Google Assistant within an app will allow you to search and find information only related to a specific app.

2. Speak into the microphone located on the top of your remote. Speech examples may be displayed depending on your model.

Using options menu

You can access to some TV settings directly by using **≡ (OPTIONS)**.

1. Press **≡ (OPTIONS)** to display options menu, then press **OK**.



2. Use **▲▼◀▶** to select a desired setting, then press **OK**.

Getting more from your TV

This section describes the overview of the Settings menu displayed when you press **🏠 (HOME)** and use **▲▼◀▶** to Select **Settings**. The **Settings** menu consists of the function setting items below.

1. Press **🏠 (HOME)** to display the Home menu.



2. Use **▲▼◀▶** to select **Settings**, then press **OK**.

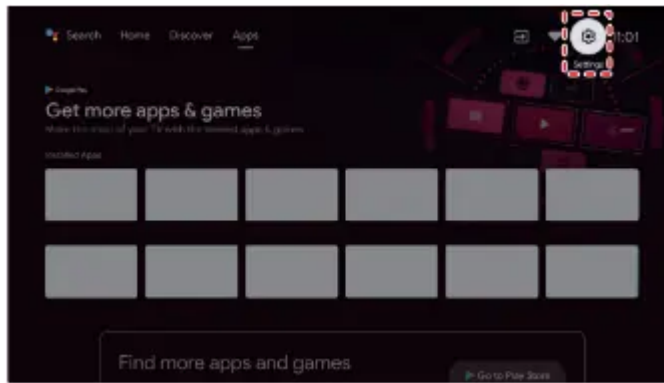

3. Use ▲▼◀▶ to select the desired menu and an item, then press **OK**.

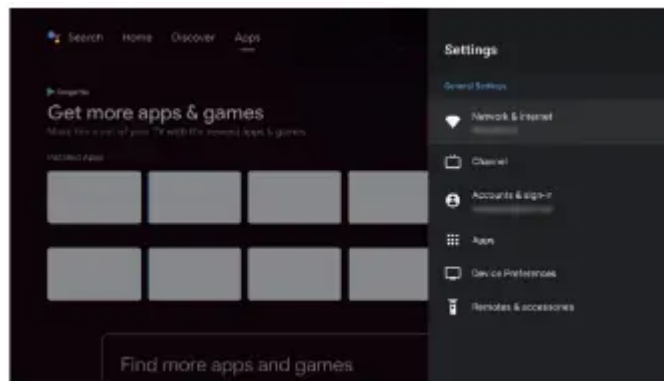

Network & Internet

Setup network connection settings in order to use apps or network upgrade functions.

1. Press **⬆️(HOME)** and use ▲▼◀▶ to select Settings then press **OK**.
2. Use ▲▼ to select **Network & Internet**, then press **OK**.

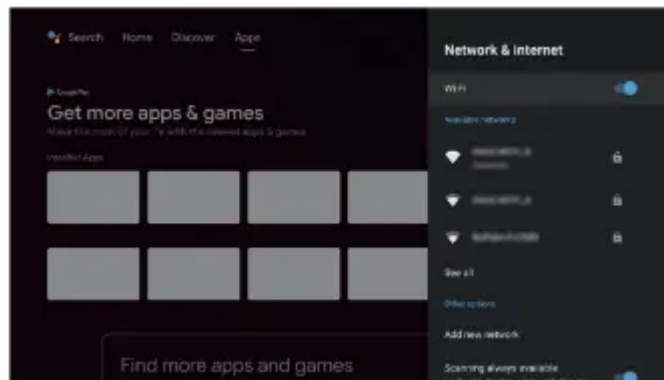

Live TV/Antenna

To select channels, use **CH + / -** on your remote. For installation of TV channels using a set-top box, go to **Connecting your devices** → **p. 14**.

Add channels

To add for the first time or additional channels, please follow the steps below:

1. On the Home menu, go to the **Apps tab** and select **How to...**

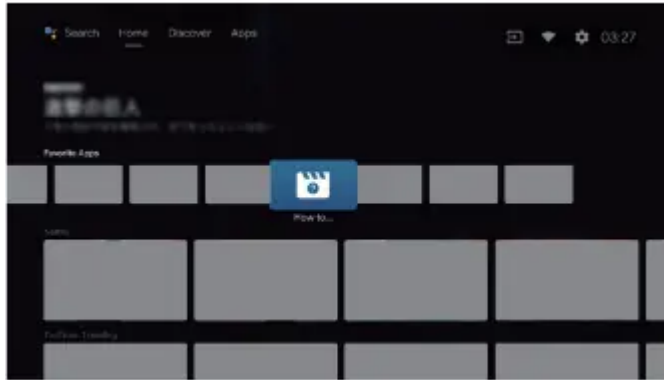

2. Select **Live TV** to open channel installation page. Once open, select **Setup** and press **OK**.

3. Select your signal type **Antenna / Cable** to start the channel installation.

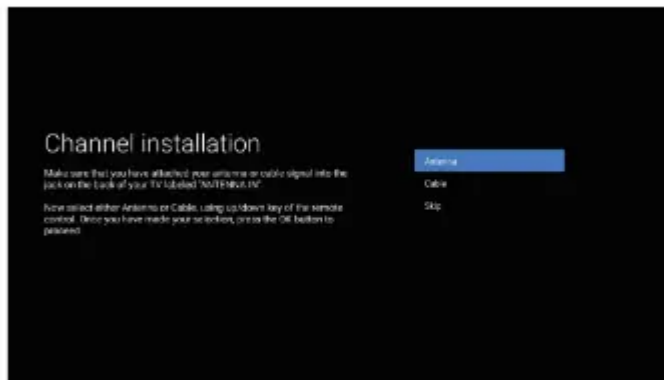

Channel list

Press **OK** while viewing Live TV to open channel list.

Program guide

To view the latest TV program schedule, press  (**TV GUIDE**) on your remote.

Note(s)

Live TV feature is only compatible with antenna and select cable broadcasting. To access your cable box or other source inputs, you must press  (**INPUT**) on your remote.

Language

You can set the language for the on-screen display.

1. Use **▲▼** to select **Language**, then press **OK**.

2. Use **▲▼** to select **English, Español** or **Français**, then press **OK**.

Note(s)

If you need the English menu instead of the Spanish or French menu's, press  (**HOME**).

Use **▲▼◀▶** to select **Settings**, then press **OK**.

Use ▲▼ to select **Language**, then press **OK**.

Use ▲▼ to select **English**, then press **OK**.

Press **⏠(HOME)** to exit the Home menu.

Keyboard

Perform the keyboard setting.

Inputs

Connected Input(s) / Standby Input(s)

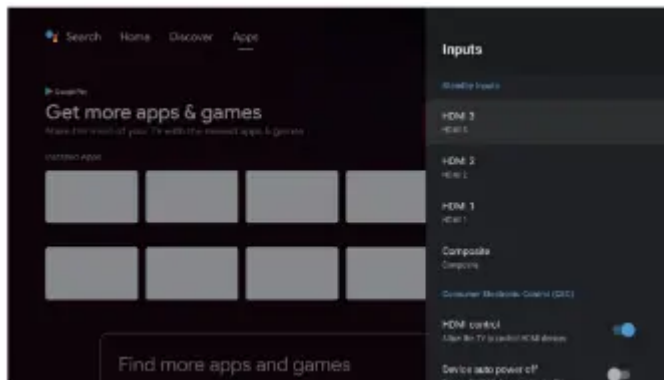

Consumer Electronic Control (CEC)

HDMI control

Allow the TV to control HDMI devices.

Device auto power off

Power off HDMI devices with the TV.

TV auto power on

Power on the TV with HDMI devices.

HDMI EDID Version

Version of HDMI EDID.

Select **EDID 2.0** for 4K@60 Hz or HDR signals. Select EDID 1.4 for legacy devices that output 4K@30 Hz or less with no HDR. HDMI EDID Version is appeared when only watching Live TV program from each HDMI connected device.

CEC Device List

Displays the connected CEC device.

Power

1. Press **⏠(HOME)** and use ▲▼◀▶ to select Settings then press **OK**.

2. Use ▲ ▼ to select **Power**, then press **OK**.

3. Adjust the following items.

Sound

1. Press **HOME** and use ▲ ▼ ◀ ▶ to select **Settings** then press **OK**.

2. Use ▲ ▼ to select **Sound**, then press **OK**.

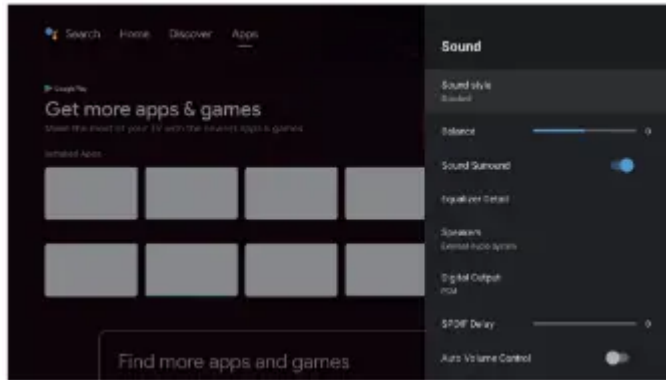

3. Use ▲ ▼ ◀ ▶ to select the item you want to adjust, then press **OK**.

The following sound settings can be configured. Depending on the format of the broadcasting, some sound settings are not available.

Sound style	User	The customized settings you preferred.
	Standard	For normal TV viewing.
	Vivid	Enhanced sound.
	Sports	Clear sound for high action.
	Movie	Powerful sound settings for a cinematic experience.
	Music	Optimized for music playback.
	News	Set the anchor's voice at a comfortable volume.

Adjust the speakers to suit your listening preference.

Balance	Cursor ◀	Cursor ▶
	To adjust the balance of the right and left speakers	

This selects sound modes for more spatial or surround sound reproduction.

Sound Surround	Off	To set Sound Surround to off
	On	To set Sound Surround to on

Adjust the tonal quality for each frequency.

Equalizer Detail	<input type="radio"/> 120 Hz
	<input type="radio"/> 500 Hz
	<input type="radio"/> 1500 Hz
	<input type="radio"/> 5000 Hz
	<input type="radio"/> 10000 Hz

You can select the audio output from the unit's speakers or not. If your amplifier is HDMI link function compatible and connected by an HDMI cable to this unit, some sound operations such as volume up can be changed by using this unit's remote. Make sure HDMI control is set to **On** → p. 28

Speakers	TV Speakers	Output from TV speakers even when an external device is connected.
	External Audio System	Output from the external audio system when an external device is connected. Output from TV speakers when an external device is not connected.

You can set the digital audio output format from SPDIF/ARC.

Digital Output	<input type="radio"/> Auto
	<input type="radio"/> Bypass
	<input type="radio"/> PCM
	<input type="radio"/> Dolby Digital Plus
	<input type="radio"/> Dolby Digital

The on-screen picture and the sound from an amplifier via the digital audio (SPDIF) output jack are synchronized by delaying the output from the connection.

SPDIF Delay	Cursor ◀	Cursor ▶
	The higher values will increase the digital audio (SPDIF) output delay.	

This function keeps a constant Loudness differential between the TV commercials and the programs.

Auto Volume Control	Off	To remove the Auto Volume Control
	On	To reduce volume differences between the TV commercials and the programs

Reset the sound settings.

Reset to Default

Accessibility

1. Press **HOME** and use **▲▼◀▶** to select Settings then press **OK**.

2. Use ▲▼ to select **Device Preferences**, then press **OK**.

3. Use ▲▼ to select **Accessibility**, then press **OK**.

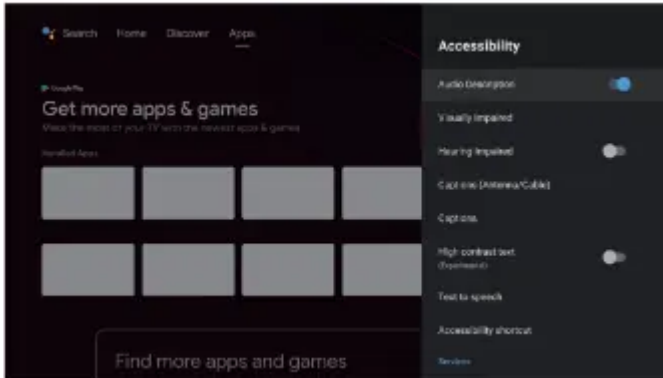

4. Adjust the following items.

Captions (Antenna / Cable)

Display	Off	Closed caption is not displayed.
	On	Closed caption is always displayed.
	CC w/ mute	Closed caption is displayed when the sound is off.
Caption service	CC-1 and T-1	The primary closed captions and text services. The closed captions or text is displayed in the same language as the program's dialog (up to 4 lines of script on the TV screen).
	CC-3 and T-3	Serve as the preferred data channels. The closed captions or text is often a secondary language.
	CC-2, CC-4, T-2 and T-4	Rarely available and broadcasters use them only in special conditions, such as when CC-1 and CC-3 or T-1 and T-3 are not available.

In addition to the basic closed caption, DTV has its own closed caption called digital caption service. Use this menu to change the settings for digital caption service.

Advanced selection	CS-1 to CS-6	Select one of these before changing any other item in Captions (Antenna / Cable) menu. Choose CS-1 under normal conditions.
--------------------	--------------	---

Useful tips

My remote does not work. What should I do?

- Check the antenna or cable connection to the main unit.

- Check the batteries on the remote.
- Check if there is an obstacle between the infrared sensor window and the remote.
- Test the IR signal output use **IR signal check** → p. 37
- If okay, then possible infrared sensor trouble.
- Aim the remote directly at the infrared sensor window on the front of the unit.
- Reduce the distance to the unit.
- Re-insert or replace the AAA batteries with their polarities (+/–) as indicated on the remote battery area.
- When there is an infrared-equipped device such as PC near this unit, it may interrupt the remote signal on this unit. Move the infrared-equipped device away from this unit, change the angle of the device's infrared sensor or turn off the infrared communication function.

How come the initial setup appears every time I turn on this unit?

- Make sure to complete the initial setup before the unit goes into standby mode.

Why can I not watch some RF signal TV programs?

- The selected channel may not be broadcasting.
- The selected channel cannot be viewed by the **Parental Controls setting** → p. 24
- The unit requires some kind of antenna input. An indoor antenna (Digital or VHF / UHF), an external antenna (Digital or VHF / UHF) or an RF coaxial cable from your wall cable or set-top box needs to be plugged into the unit.

How come there is no image from the connected external devices?

- Check if the correct input is selected by pressing **(INPUT)** → p. 18
- Check the antenna, cable or other input connection to the unit.

When I enter a channel number, why does it change automatically?

- Many digital channels have alternate channel numbers. The unit changes the numbers automatically to the ones signifying the broadcasting station's channel number. These basic numbers used for the previous analog broadcasts. (e.g., input digital ch# 30 automatically changes to digital ch# 8.1)

Why are captions not displayed entirely? Or why are captions delayed behind the dialog?

- Closed captions that are delayed a few seconds behind the actual dialog are common for live broadcasts. Most captioning production companies can display a dialog to maximum of 220 words per minute. If a dialog exceeds that rate, selective editing is used to insure that the closed captions remain up-to date with the current TV screen dialog.

How can I set the clock?

- From the Android TV home screen, select **Settings** in the upper right of the screen. Scroll down to **Device Preferences** and select **Date & time**. Please set it automatically or manually.

Troubleshooting tips

If the unit does not perform properly when operated as instructed in this manual,

Please check the following Troubleshooting tips and all connections once before calling for service.



Power

No power

- Make sure the AC power cord is plugged in.
- Make sure that the AC outlet supplies the proper voltage, plug another electrical appliance into the AC outlet to ensure that the AC outlet operates normally.
- If a power failure occurs, unplug the AC power cord for 1 minute to allow the unit to reset itself.

Slow start up

Your TV takes a long time to start up when you turn it on.

- When powering off the TV into Low Power Standby, there will be a longer load time when powering it back on.
- Press and hold the 9  (POWER) button for 1 second or more to go into Low Power Standby. Power consumption in this mode will be reduced (≤ 0.5 W).
- Pressing the 9  (POWER) button for less than 1 second will put the TV into Quick Start Standby, which will have a quicker boot time when powering back on. Power consumption in this mode will be slightly higher. For more details, please visit web philips....

Remote

Control buttons do not work.

- Do NOT press more than one button at the same time.
- Ensure that no buttons on the remote are depressed and move freely.
- Re-insert or replace the AAA batteries with their polarities (+/-) as indicated on the remote battery area.

Universal remote does not work properly.

- Refer to the user manual of the universal remote for the Philips code.

- Remote buttons are not functional.
- Re-insert or replace the AAA batteries with their polarities (+/–) as indicated on the remote battery area.

The Google Assistant button on your remote doesn't work

- Make sure the remote is connected to the TV via Bluetooth. Google Assistant uses Bluetooth to create a safe connection between the remote and TV. (See step “7 Connecting your devices” in the Quick start guide for details)
- Make sure the Google Assistant feature was activated during initial installation. To check this, go to **Settings > Device Preferences > Google Assistant > Accounts** to see if you are logged into an active account.

Performance

Remote response is delayed or sluggish during initial use.

- Your television is automatically, downloading and installing the latest applications, for the best user experience.
- During this time, you may experience a delayed response from your remote. Upon successful installation, your remote will operate normally.

Accessibility

Television is speaking prompts out-loud.

- To disable the TalkBack on your television, press **(HOME)** on your remote, navigate to settings icon in the upper right corner of the home screen and select **Device Preferences > Accessibility**, select **TalkBack**, press **OK** to toggle between on or off.

Picture

Power is on but screen image is off.

- Check if the connection for your source device is properly secured.
- Check if the correct input is selected by pressing **(INPUT)**.
- Verify that your HDMI mode, for the input selected matches the resolution output of your source device. Change source input until you have picture and sound.

Picture on HDMI Input

Television has sound with no picture or abnormal picture.

- HDMI EDID Version setting is set to a different mode than your source device. To change it, refer to the step “7 Connecting your devices” in the Quick start guide and see “Changing input to devices that are connected to the TV”.
- Change the resolution output of your source device.

Sound

No sound is heard when using the HDMI digital connection.

- Some HDMI cables and devices may not be compatible with the TV due to different HDMI specifications.

No sound, distorted sound or incorrect audio sound is heard when using the HDMI-DVI connections.

- Make sure that the analog audio signals from the HDMI-DVI device are connected to the analog audio input L/R jacks.
- When using Composite analog video, make sure that the analog audio (L/R) connectors are mounted into the audio (L/R) input jacks.

No sound from Soundbar / Home theater using an HDMI cable.

- Please check to be sure the device is connected to the HDMI 2 (ARC) input on the TV.

Sound intermittent or no sound.

- Check if the audio cable is connected into the unit correctly.

You switch to a different input and the volume changes.

- This unit will memorize the volume level from the last time you adjusted it.
- If the volume of the sound from another device is higher or lower, then the loudness will change.
- Make sure Auto Volume Control is set to **On** → **p. 30**

Picture & Sound

No sound with distorted picture occurs when using the HDMI digital connection.

- Some HDMI cables and devices may not be compatible with the TV due to different HDMI specifications.

No picture or sound

- Check if the power is on.
- Check whether all the cables to the unit are connected to the correct output jack on your separate device like Blu-ray Disc™ / DVD recorder.
- View other TV channels. The problem might be limited to the broadcasting station or weak signal strength.
- Unplug the AC power cord and wait for about 1 minute, then plug the AC power cord and turn on the unit again.
- Check whether the connection of the antenna or cable / satellite set-top box is connected correctly.
- Make sure that the selected input mode is connected to the working input jack.

- Make sure that the sound is not muted. Press 2 (MUTE) so that the volume bar and current volume level will appear on the TV screen.
- Make sure that the volume is NOT set to 0 or 2 (MUTE). If so, use VOL + / – to adjust to the desired volume.
- Make sure that the headphone is NOT connected to the headphone audio output jack.
- If there are issues with picture/color and/or sound when connecting an external device using the HDMI port, please try switching the **HDMI EDID Version. (Refer to HDMI EDID Version L p. 15)**

Adjusted Picture or Sound settings are not effective every time the unit is turned on.

- You need to turn off the Retail Mode setting. L p. 30 (Otherwise, the settings you adjusted will not be memorized after the unit goes into standby mode.)

You see a distorted picture or hear an unusual sound. (Analog TV - NTSC signal)

- You may be getting NTSC (Analog) TV signal (not HDTV signal) interference from electrical appliances, automobiles, motorcycles or fluorescent lights.
- Try moving the unit to another location to see if this is the cause of the problem.

Ghosts, lines or streaks in picture.

- Electrical interference from nearby appliances may affect picture quality.
- View other TV channels. The problem might be limited to the broadcasting station or weak signal strength.

Picture poor, sound intermittent or no sound

- View other TV channels. The problem might be limited to the broadcasting station or weak signal strength.

Screen

You switch to a different input and the screen size changes.

- This unit will memorize the viewing mode from the last time you used the particular input modes.

The display image does not cover the entire screen.

- If you are watching TV or using the composite video or HDMI with 480i input, select Picture format, and then switch to various screen modes. (Refer to **Picture format** → p. 20)

Different color marks on the TV screen

- View other TV channels. The problem might be limited to the broadcasting station, missing data or pixelation due to weak signal strength.

Closed captions

Closed captions are displayed as a white box. No closed captions are displayed in the closed captions-supported program.

- Interference from buildings or weather conditions may cause closed captions to be incomplete if watching analog TV signals.
- Broadcasting station may shorten the program to insert advertisements. The closed caption decoder cannot read the information of the shortened program.

Black box is displayed on the TV screen.

- The text mode is selected for caption. Select CC-1, CC-2, CC-3 or CC-4.

Software update

A message appears on the screen prompting for software update again.

- When you start up the TV or a net service after executing the software update, a message may appear on the screen prompting for software update again. In this case, please execute the software update. (start from **Settings > Device Preferences > About > System update**)

Network

Cannot connect to the network.

- Check if your router and/or modem is properly connected.
- Check if the Ethernet cable connection between the TV and your router or modem is properly secured.
- Power cycle the router and/or modem.
- Check your network settings.

Sometimes video quality is poor when using the wireless LAN.

- The wireless network connection quality varies depending on the distance or obstacles (e.g. wall, basement, 2nd floor) between the TV wireless LAN adapter and the wireless router (access point), from other wireless networks, and brand and type of the wireless router (access point). When using the wireless LAN of the TV, it is suggested to place the wireless router as close as possible to the television.

Wireless LAN connection fails or wireless connection is poor.

- Check the installation location of the TV and wireless router (access point). Signal quality may be affected for the following reasons.
 - Interference of other wireless devices, microwaves, fluorescent lights, etc., are placed nearby.
 - There are floors or walls between the wireless router and TV.

- If the problems continue even after checking the above, try making a wired LAN connection.

Cannot use the wireless connection.

- Check if the wireless LAN Access Point (AP) (e.g. wireless router) is oriented properly or not placed too close between them.
- Once you have activated the wireless connection please wait 30 seconds for the connection to be established after turning on the unit, before trying to access network features.

Slow Data Connection or buffering.

- Check the settings between your router and ISP modem or gateway (if applicable).
- Connect to a stable wireless connection from home wireless or wired network.
- The use of mobile hot spots or public wireless connections is not recommended.

Cannot use Netflix feature.

- Check if the network connection is properly made.
- Visit web.netflix.. on your PC and become a Netflix member.
- Some network services may not be available in your country.

Cannot add movies or TV episodes to the Instant Queue.

- Visit web.netflix on your PC.

Even though the speed of the internet connection improves during playback, the picture quality of Netflix streaming movie does not improve.

- The picture quality does not change during playback. It differs depending on the speed of internet connection at the time of loading.

Cannot use VUDU feature.

- VUDU is available only in the United States.
- Check if the network connection is properly made.

Cannot rent or buy movies / TV episodes on VUDU.

- You need to activate the VUDU account. For detailed information, please visit the service providers website at web.vudu...
- Log into your account at web.vudu... and check your payment information.

The picture quality of a streaming movie (Netflix or VUDU) is poor.

- Check the speed of your internet connection. You need speeds of at least 8 Mbps to this player for high quality uninterrupted playback.

Streaming movie (Netflix or VUDU) often stops or starts buffering during playback.

- Contact your internet service provider to troubleshoot your internet connection for speed and line quality. Consistent line quality and speed are very important for internet video playback.

Cannot connect to the network while my PC is connected to the network.

- Check the content of your internet service contract to see if your internet service provider prevents multiple terminals connecting at the same time.

Folder or files stored on home network media server are not displayed in the file list or cannot be played back.

- Check the setting on your home media server. (Refer to the user manual of the home media server.)
- Check the network connection and settings.

Google Duo

USB camera does not work

- Check if USB camera supports Android 9.0 or later.
- May be listed on USB camera packaging or manufacturer's website)
- Check if USB camera is connected to the TV.
- Turn off the TV and disconnect/reconnect USB camera. Turn the TV back on and reopen the Duo app.
- If issues remain, please visit the Duo support page and check the Troubleshoot section.

**Other party cannot hear anything
(My microphone does not work)**

- Check if USB camera has a built-in mic and supports Android 9.0 or later. (May be listed on USB camera packaging or manufacturer's website)
- Check if your microphone is muted. (Please unmute if so)
- Check if USB camera is connected to the TV.
- Turn off the TV and disconnect/reconnect USB camera. Turn the TV back on and reopen the Duo app.
- If issues remain, please visit the Duo support page and check the Troubleshoot section.

I cannot hear other party

(Speaker does not work)

- Check if the volume of the TV is muted or very low. (Please unmute or turn the volume up if so)
- Check if USB camera is connected to the TV.
- Turn off the TV and disconnect/reconnect USB camera. Turn the TV back on and reopen the Duo app.
- If issues remain, please visit the Duo support page and check the Troubleshoot section.

Where can I find Google Duo app?

- Open the Google Play store and search “Google Duo”. From here, you can download or open the app. Once downloaded, you will be able to find it in the Apps tab in the home screen.

Note(s)

- The LCD screen is manufactured to provide many years of useful life. Occasionally a few non active pixels may appear as a fixed point of blue, green or red. This is not to be considered a defect in the LCD screen.
- Some functions are not available in specific modes, but this is not a malfunction. Read the description in this manual for more details on correct operations.

For additional troubleshooting, refer to the Frequently Asked

Warning

This content is compiled from multiple sources and is provided for reference purposes only. It may not be complete or fully applicable to all situations. If you are unable to resolve your issue, please contact the product manufacturer or an authorized service provider for official support.