

## PRODUCT OVERVIEW

### eufy Indoor Cam 2K Pan & Tilt

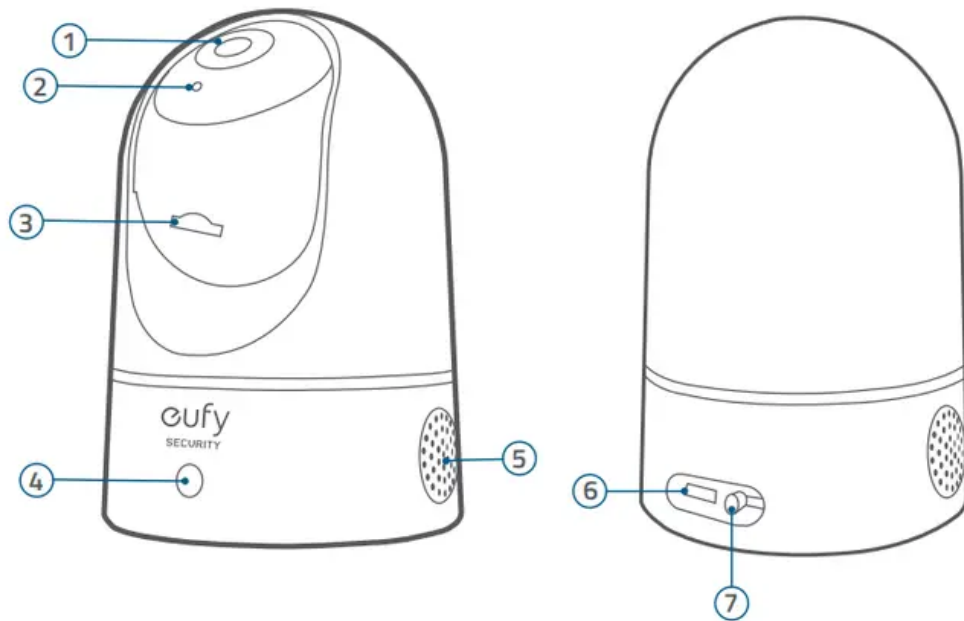

1 Lens

2 Microphone

3 SD card slot

4 Status LED

5 Speaker

6 Power input

7 SYNC button

## SETTING UP THE SYSTEM

1. Download the eufy Security app from the App Store (iOS devices) or Google Play (Android devices).



2. Sign up a eufy Security account. Go to the app homepage. Tap Add Device, and add the IndoorCam Pan 2K to your system.
3. Follow the on-screen instructions to complete the setup.

### LED Status

LED Status	Description
Breathing blue	Ready for setup
Solid blue	Powered on and working properly
Blinking red	Disconnected from the internet
Blinking red once	Motion or sound detected
Solid red	Working properly with someone viewing the live stream or recording event
Solid bluish violet	System is initializing
Flashing blue and red alternately	Firmware upgrade in progress

## MOUNTING THE INDOOR CAM

### Select a Location for Mounting

- The camera can be placed on a table, shelf, or can be mounted on a wall or ceiling. Select a location and height where you can get the desired view, and can reach a power outlet easily.

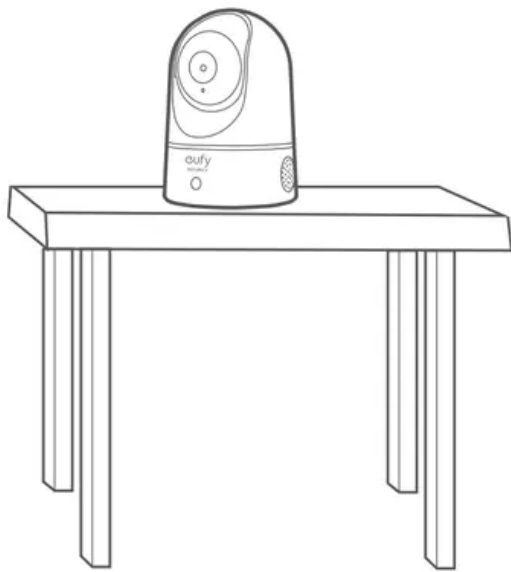

- Disconnect the Indoor Cam from the power outlet before mounting.
- Keep the eufy Indoor Cam at least 0.7 ft / 20 cm away from walls or anything that may obstruct the view. Do this to avoid infrared reflection which can have a negative impact on the night vision performance.

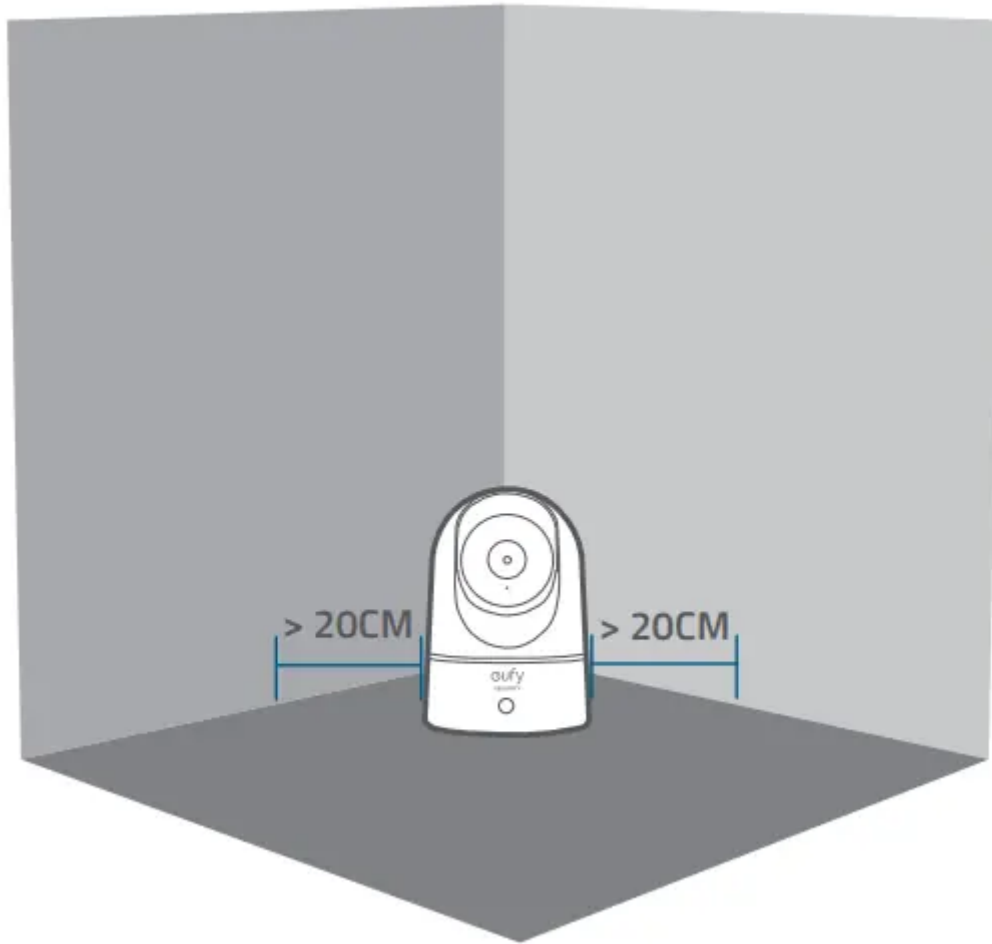

## Mount the Indoor Camera

To mount the eufy Indoor Cam on the ceiling, follow the steps below:

1. Place the positioning card against the ceiling and then mark the points at which drilling will be required.

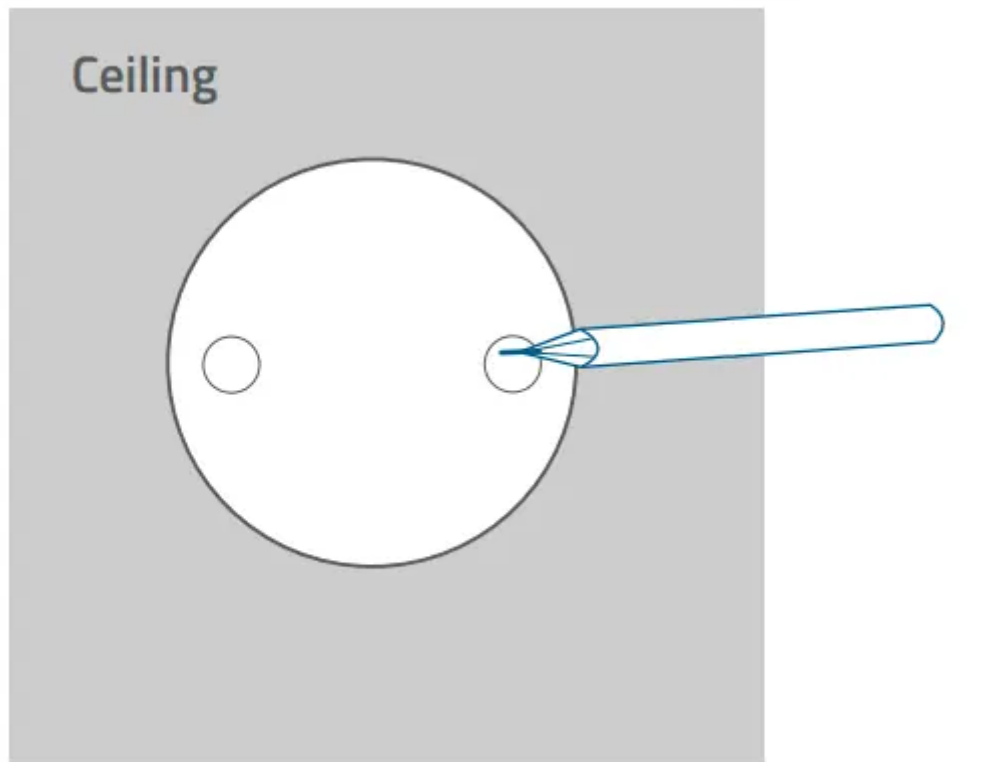

2. Drill holes with a 5/16" (8 mm) drill bit.

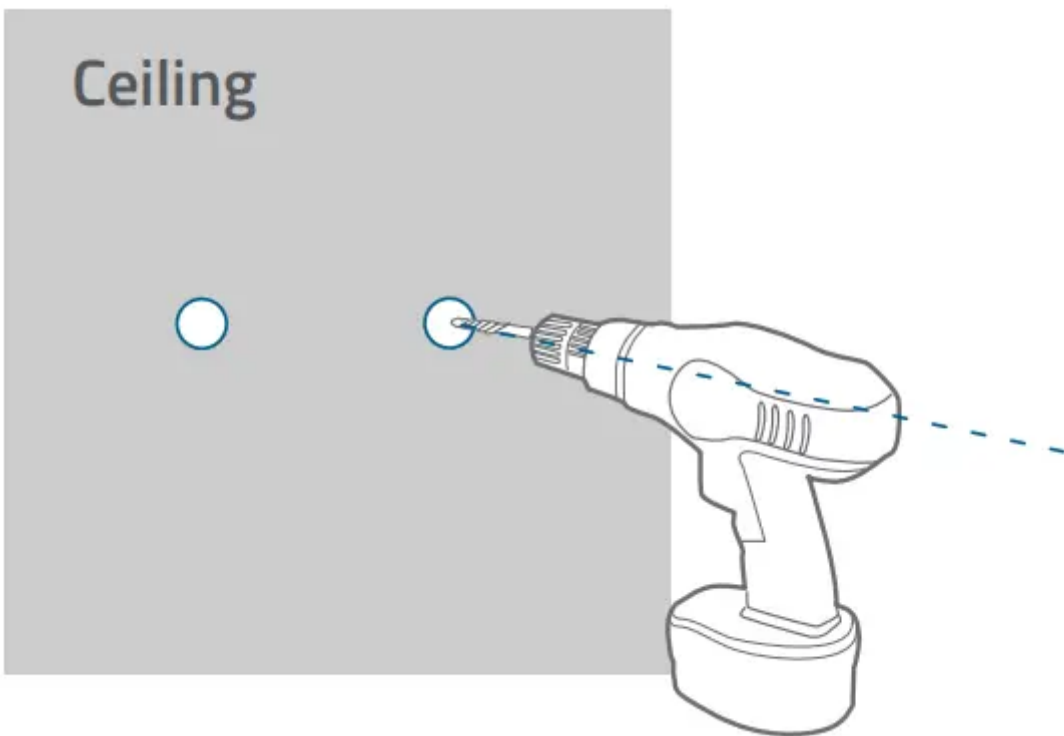

3. Align the holes on the mounting plate with those in the ceiling. Insert the anchors into the holes; anchors are necessary for walls that are made out of hard materials such as concrete, brick, or stucco. Fix the screws with a Phillipshead screwdriver to fasten the mounting plate to the ceiling.



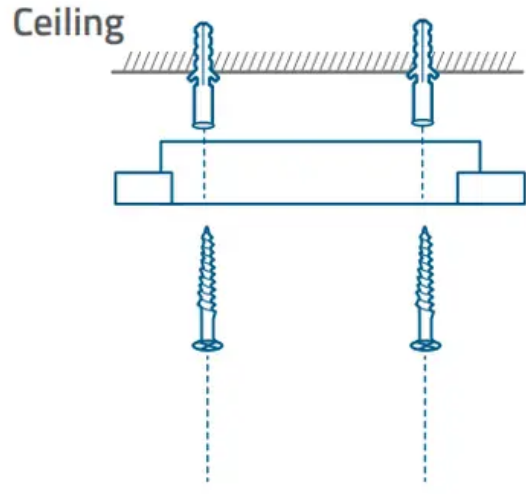
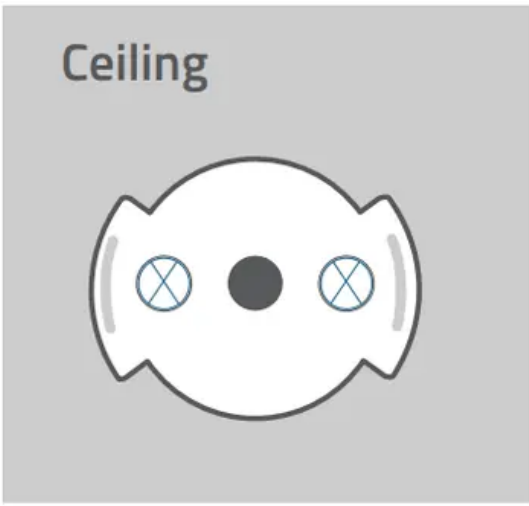

4. Align the grooves with the mounting plate and rotate the eufy Indoor Cam clockwise until it clicks into place.

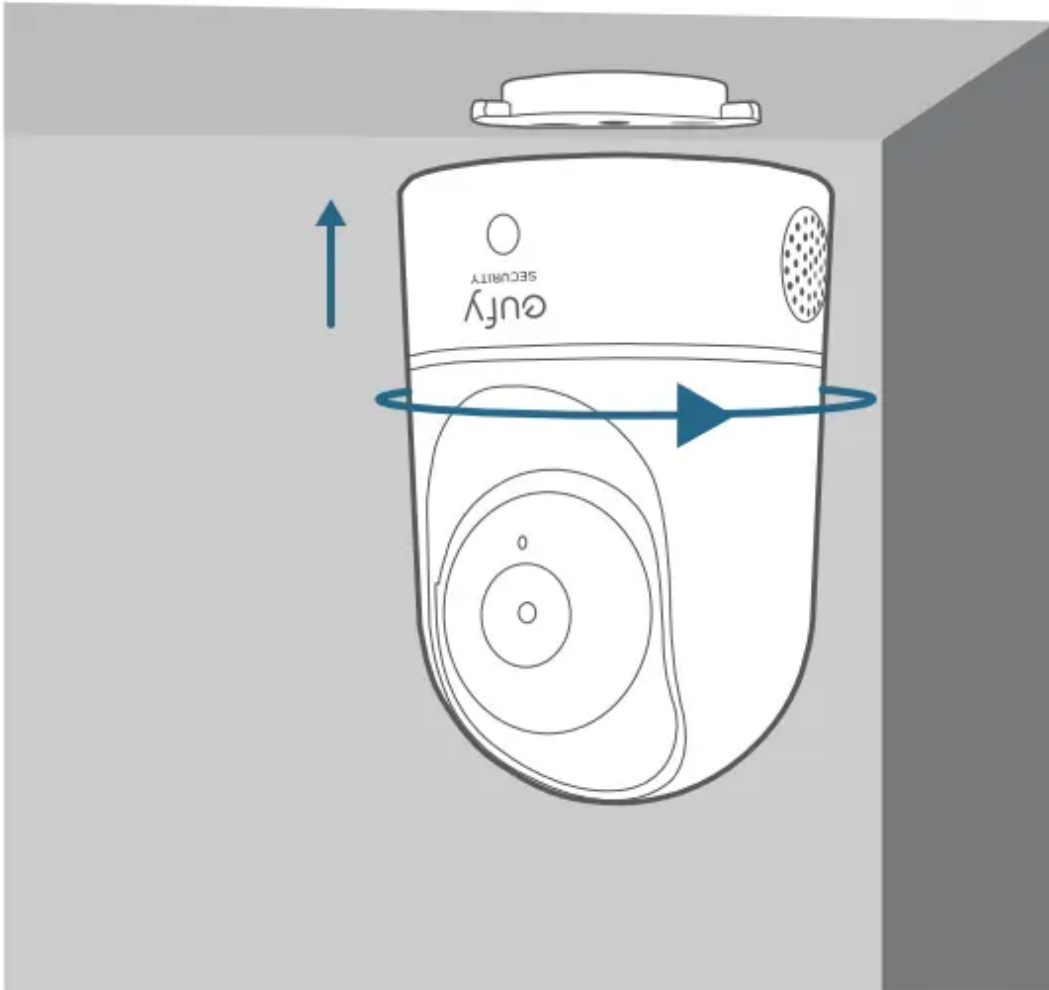

To mount the eufy Indoor Cam on a wall, we recommend using the mounting bracket (not provided) as the illustration below.

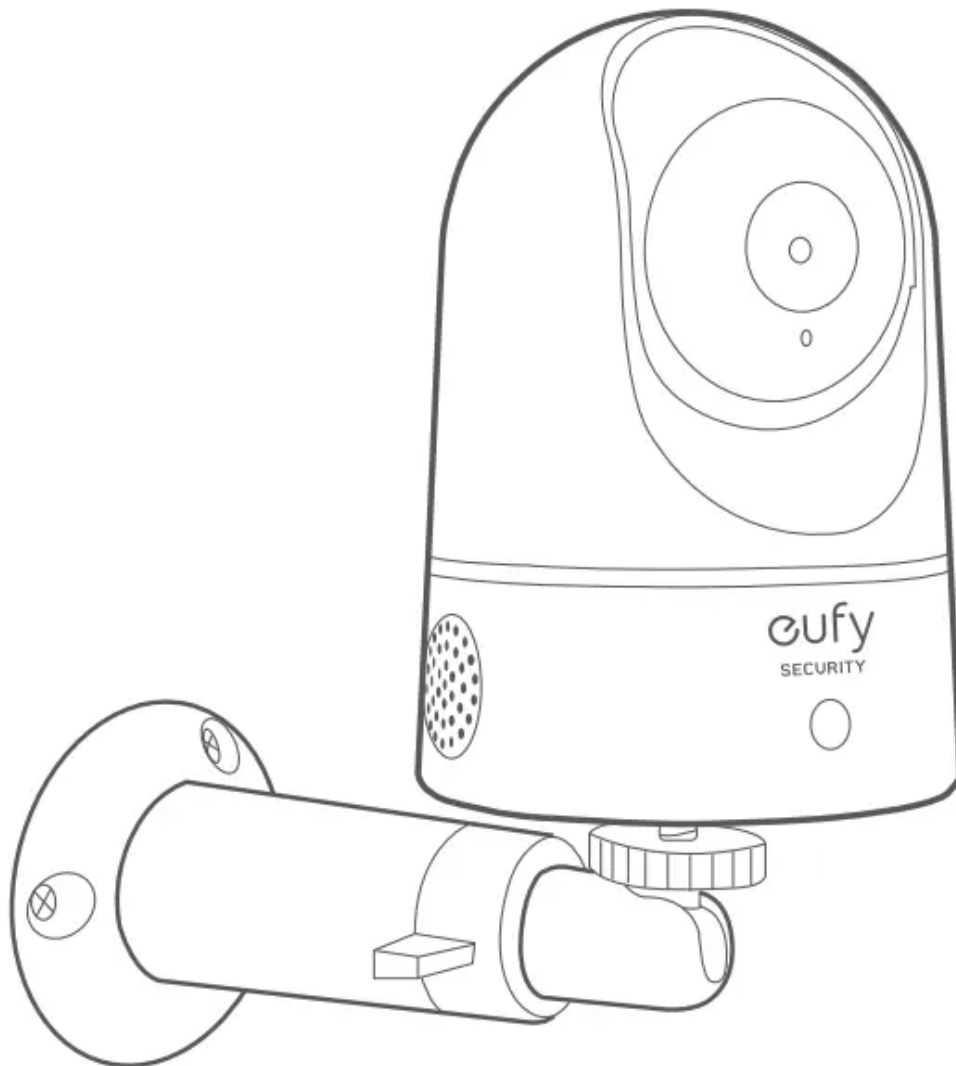

## POWERING ON THE INDOOR CAM

- Connect the eufy Indoor Cam to a power outlet using the provided USB cable and USB adapter. After being powered on, the eufy Indoor Cam will be connected to the system. When it is successfully connected, the status LED will turn solid blue.
- Rotate the eufy Indoor Cam to adjust the view and check it using the live stream which you can access in the eufy Security app. You are now all set to use your eufy Indoor Cam.
- Tip: For troubleshooting, check Help on the eufy Security app. Refer to the app page for LED indicator status.

## FAQ

**1. What are the differences between HomeKit, HomeKit Secure Video, and eufy Security App on Indoor Cam?**



Feature	HomeKit	HomeKit Secure Video	eufySecurity App
Live Stream	Yes	Yes	Yes
Pan & Tilt Control	No	No	Yes
Remote Access	Yes / home hub	Yes / home hub	Yes
2-way Audio	No	No	Yes
Local Storage	No	No	Yes
Cloud Storage	No	Yes / \$2.99 or above iCloud plan.	Yes
Video Encryption	Yes	Yes	Yes
AI	No	Yes (People / Pets/ Vehicles) Analyzed by home hub.	Yes (People / Pets/ Vehicles) Analyzed by home hub.
Adjustable Sensitivity	No	No	Yes
Activity Zones	No	Yes (iOS 14 later )	Yes
Sound Detection	No	No	Yes
Notification Type	No	No	Yes
Timestamp	No (By default)	No (By default)	Yes
Home/Away Mode	No	Yes	Yes
Works with Siri	Yes	Yes	No
Works with Alexa	No	No	Yes
Works with Google	No	No	Yes
		Yes / home hub	



HomeKit Automation	Yes / home hub		
App for Tablet	Yes	Yes	Yes

Note: Feature availability and performance may vary on later firmware.

## 2. What's the requirement to use HomeKit Secure Video?





1. An iPhone, iPad, or iPod Touch with iOS 13.2 or later. We strongly recommend HomeKit Secure Video users upgrade to this version before using HomeKit Secure Video.
2. The Home app set up on your iOS device using the Apple ID that you use with iCloud.
3. An iPad, HomePod, or Apple TV.
4. A 200GB or above iCloud storage plan.



## 3. Why do I need to have a home hub to use HomeKit Secure Video?

- HomeKit Secure Video is designed to rely on a home hub. Without a home hub, HomeKit Secure Video options won't be available even if the IndoorCam system is upgraded to compatible firmware.
- With a home hub, users can control their HomeKit accessories remotely, grant access to the people they trust, and automate their accessories to do what they want, when they want
- Users can set up a home hub on an iPad, Apple TV or HomePot.

## 4. What will change after I enable HomeKit Secure Video?

Since Apple has specific requirements for HomeKit certification, to avoid functional conflicts, the following functions will be activated/disabled via HomeKit request.

Feature	eufy Security function difference	Remark
 AI/sound detection /pet commands	Disabled. (Avoid conflict between eufy local AI processing and HomeKit AI running at the same time.)	Disabled. (Avoid conflict between eufy local AI processing and HomeKit AI running at the same time.)
 Activity Zones		
 Cloud storage & NAS	Disabled	Available Storage Option 1. Local storage 2. HomeKit Secure Video
 Watermark	Turned off by default.	Turn on eufy App settings if necessary.
 Video resolution	Home App can't access videos on Indoor Cam's microSD card.	The video resolution will be set to the Apple HomeKit standard of 1080p, and the dynamic code stream will be adjusted according to the network situation (including switching back to eufy App).

 <p>Recording</p>	<p>Home App can't access videos on Indoor Cam's microSD card.</p>	
 <p>Directional control</p>	<p>Home App can't control device direction.</p>	<p>Return to the eufySecurity app to access this feature.</p>

**5. Will I receive the notification on both iOS Home App and eufy Security App?**

- Yes. Users will receive notifications from both Apps.

**Warning**

This content is compiled from multiple sources and is provided for reference purposes only. It may not be complete or fully applicable to all situations. If you are unable to resolve your issue, please contact the product manufacturer or an authorized service provider for official support.

