

Attentions

Thank you for purchasing your new Ultrasonic Humidifier.

The humidifier helps you to restore an appropriate level of humidity and eliminate the discomfort associated with dry air. We wish you many years of healthy indoor air with this efficient and effective product.

We recommend you spend some time reading this instruction manual in order to fully understand all the operational features it offers.

* Read all the safety instructions carefully before use and keep this instruction manual for future reference.

Warning: Please be aware of the following points or you might be in danger of high voltage charges or burn your body.

1. Never disassemble the base unit without consulting qualified personnel.
2. If the supply cord is damaged, it must be replaced by the manufacturer, its service agent or similarly qualified persons in order to avoid a hazard.
3. Unplug appliance during filling, cleaning and maintenance.
4. Keep detergents and chemical solutions away from children.
5. Do not change attachment without definitive permission from our company otherwise you might cause a hazard.
6. If any abnormal smell during normal operation, please switch off and disconnect power supply and ask qualified personnel help.
7. If when cleaning with water, detergents & chemical solutions splash into mouth & eyes, consult a doctor to refrain from serious hazard.
8. Never touch water in the water tank & components in the water when the unit is in function.
9. Never switch on when there is no water in the water tank.
10. Never scrape transducer on your own.
11. Never let water splash into inner base unit to avoid components damage.
12. Care should be taken when using the appliance due to emission of hot water vapor.
13. Before cleaning and maintenance, the appliance must be disconnected from the power supply.
14. Prior to cleaning or other maintenance, the appliance must be disconnected from the supply mains.

15. This appliance can be used by children aged from 8 years and above if they have been given supervision or instruction concerning use of the appliance in a safe way and if they understand the hazards involved. Cleaning and user maintenance shall not be made by children unless they are older than 8 and supervised. Keep the appliance and its cord out of reach of children aged less than 8 years. Cleaning and user maintenance shall not be made by children without supervision.

16. Children should be supervised to ensure that they do not play with the appliance.

17. Indoor use only.

Operation steps

Instructions For Usage

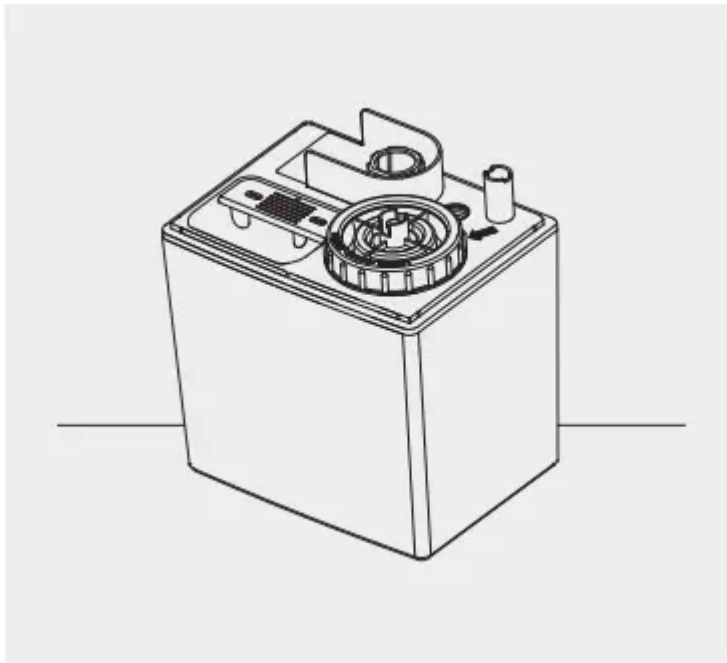

1. Put the machine on a flat surface.

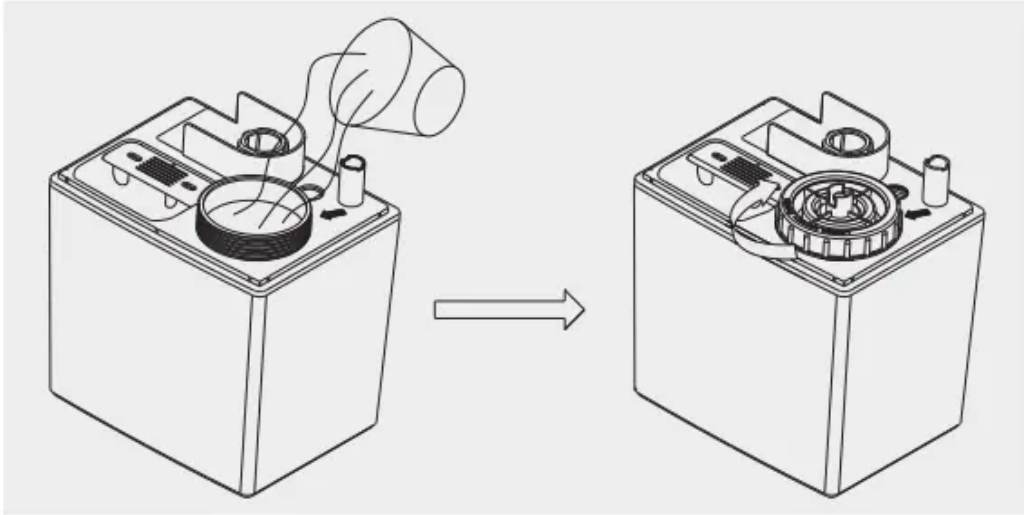

2. Fill the water into the water tank, and then tighten the tank cover.

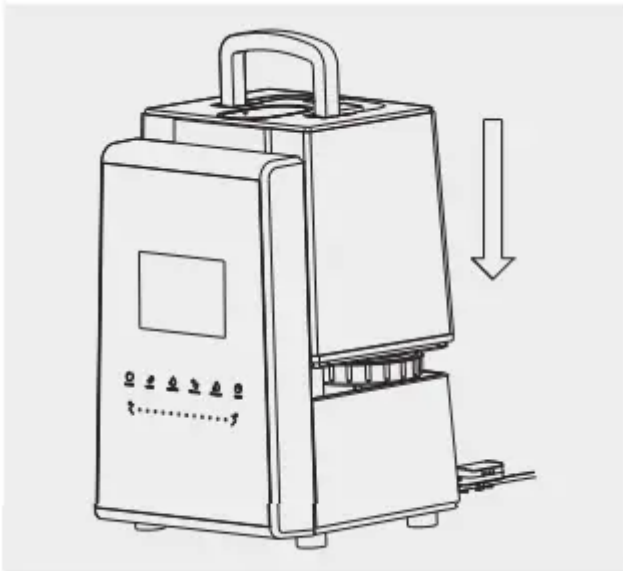

3. Put the water tank on the main base



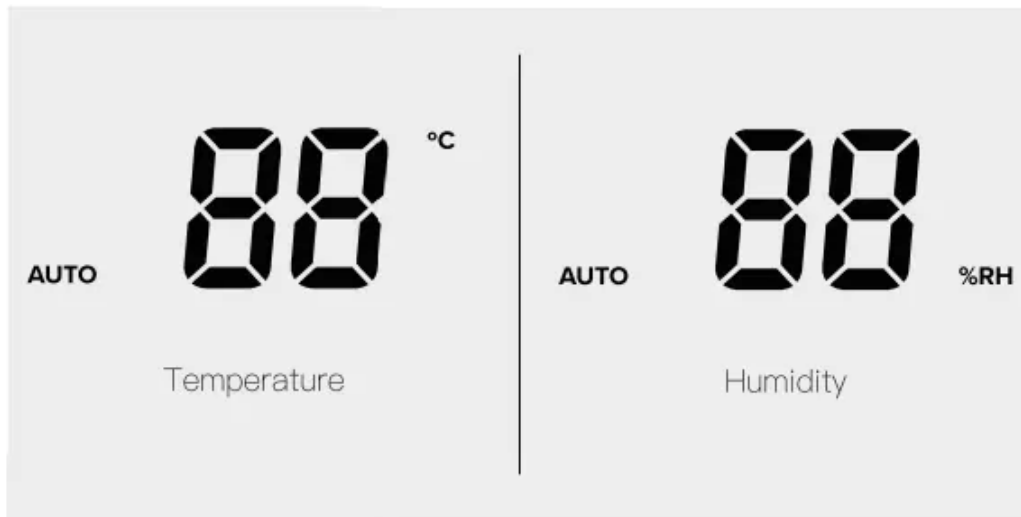

4. Check if the rated voltage meets the input voltage and plug into the socket. Then display shows the current temperature and humidity.



5. Touch the symbol POWER “  ” on the machine. The machine will begin to work in AUTO mode. Display shows AUTO symbol.

Temperature of the air (°F)	<=66	68	70	72	74	76	78	80	82	84	86	88	90	92	94	96	98	100	>=102
Temperature of the air (°C)	<=18	20	21	22	23	24	26	27	28	29	30	31	32	33	34	36	37	38	>=39
Humidity(%)	65	60	58	57	55	53	50	48	45	43	40	38	36	35	34	32	31	30	25



6. Touch the symbol ANION “  ” the anion generator works. On the LED display, it shows



the shape of anion “  ”. Touch again to stop the function.





7. Touch the symbol HEATING “  ” the warm mist will come out after 10~15 minutes. On the







LED display, it shows the same symbol “  ”. Touch again to stop the function. Mist will become cool.





8. Constant humidity: Before you touch the symbol HUMIDITY “  ”, LED display shows the current humidity. You may set the humidity arranged from 30%RH to 75%RH. It will increase by 5%RH.

9. Touch the symbol MODE “  ”, baby mode will be turn on (keep constant humidity at 55% with warm mist and anion turn on). In baby mode,mist output speed cannot be set. Press symbol

MODE “  ” again to enter auto mode. Press MODE “  ” for two seconds to enter sleep mode. In sleep mode, display and water tank indication light will turn off and “  ” will be turn on. Humidifier will keep running. Touch any button to cancel sleep mode and display will turn on.

10. Timer setting: There are 12 timer setting: 1,2,3,4,5,6,7,8,9,10,11,12 hours. Touch the symbol TIMER “  ”, the LED display will show the desired setting timer. The timer shows the rest operation time and decreases by 1 hours.

11. Auto Shut-Off: Once the water in the basin is too little to keep the machine working, the machine will automatically stop working. LED shows the shape of lack of water “  ”. Refill the water, and the machine will restart. If don't refill water within 15 minutes, the machine will automatically power off.

12. Slide the symbol MAX-MIN “  ” (AUTO mode is cancelled and the mist output is in the first speed. You may select 7 desired levels of mist volume. The corresponding strip symbol will appear on the display.

13. On the remote controller, the related symbol controls the corresponding function

- Take the water tank out of the unit, open the water tank cover and fill the tank with clear water. Close the cover and put the tank onto the base unit carefully.
- Put the nozzle into the socket on top of the water tank.
- Connect the power supply, switch on the unit (NEVER RUN THE UNIT WHEN THERE IS NO WATER IN WATER TANK), the main connection lamp will on. The unit will begin working.

Maintenance Instruction

TECHNICAL DATA

- **Model: 808C**
- Heating power: 80W
- Humidify power: 30W
- Noise level <38dB(A)
- Total power: 110W
- Water tank capacity: 5.3L(1.4gal)
- Evaporation Rate: >350mL/h

- Power supply:

(US: 120V 60Hz) (UK: 230V 50Hz)

Maintenance

In a case when the water is hard which means water contains too much calcium and magnesium, it can cause a “white powder” problem and leave heavy scales on the surface of water tank, transducer and inner surface of the water tank. Scales on the surface of transducer will let the unit work improperly.

We recommend

1. Use cold boiled water or distilled water.
2. Clean the transducer, water tank and basin unit every week.
3. Change the water in water tank more often to keep it fresh.
4. Make sure to pull out the water from the water tank and dry the water tank before you store the unit unused for a long period of time.
5. Clean the whole unit and make sure that all parts of the unit are dried completely before unused for longer period of time.

How to clean the basin unit

1. Clean the water tank with soft cloth and the cleaning abluent if there is scale in it.
2. If the scale is covered on the security switch, drop the cleaning abluent on the scale and clean it out with the brush.
3. Rinse the water tank with clean water.

Trouble Shooting Guide

If any trouble is found in normal operation, please kindly refer to the following points:

Trouble	Possible reasons	Solution
Power lamp off, does not work	No power supply	Connect power supply, switch on
Power lamp on, no mist outlet with wind	1. No water in water tank 2. Security switch is too loose	1. Fill water into water tank 2. Tighten the switch
Abnormal smell mist	1. New unit 2. Dirty water or water sitting too long	1. Take out water tank, open cover, let it stay 12 hours in cool position 2. Clean water tank, fill with clear water
Power lamp on, unit doesn't work	Too much water in the water tank	Pull out same water from the water tank, close the cover of water tank tightly
Mist fog is too low	1. Too much scale in the water tank 2. Water is too dirty or water kept too long in the tank	1. Clean transducer 2. Clean water tank, change to fresh clear water
Abnormal noise	1. Resonant in water tank when water is too low 2. Unit is on a unstable surface	1. Fill water into water tank 2. Move the unit to a stable flat surface
Mist fog coming out from around nozzle	There are apertures between the nozzle and water tank	Dip the nozzle in water for a while and then fix it to the socket on water tank

X DISPOSAL

Do not dispose this product as unsorted municipal waste, collection of such waste separately for special treatment is necessary.

Warning

This content is compiled from multiple sources and is provided for reference purposes only. It may not be complete or fully applicable to all situations. If you are unable to resolve your issue, please contact the product manufacturer or an authorized service provider for official support.

Document generated by [ManualsFile](#)