

## Parts and Features

**BEFORE FIRST USE:** Wash all removable parts in hot, soapy water. Rinse and dry. Wipe base clean with a damp, soft towel. Do not immerse base in water or other liquid.

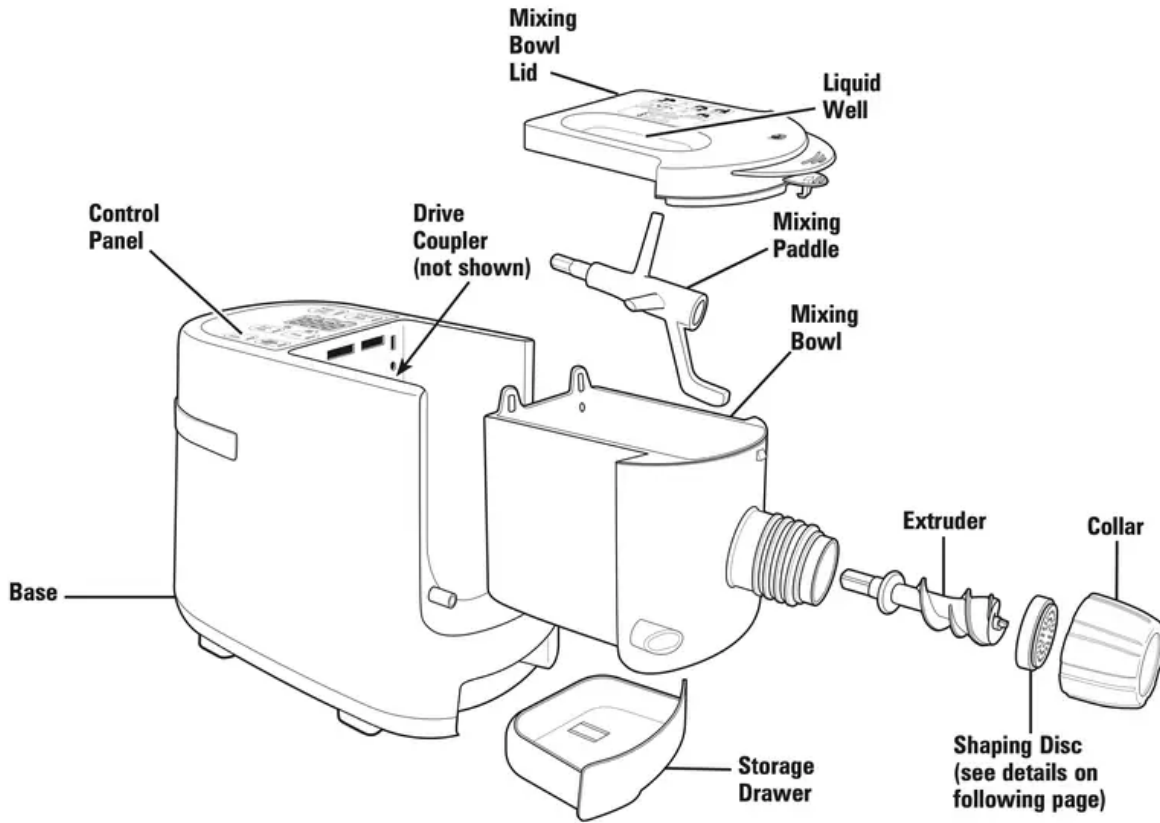

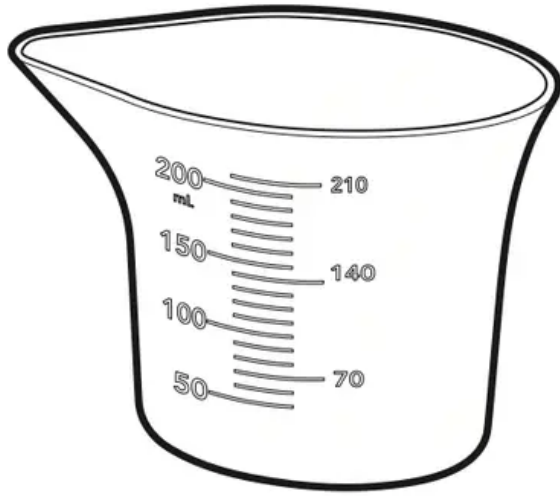

**Liquid  
Cup (ml)**



**Flour  
Cup**

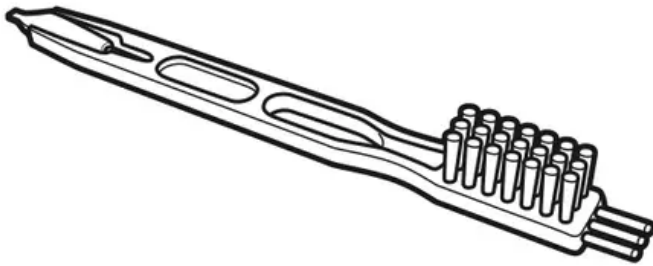

**Cleaning  
Tool**

Shaping Discs

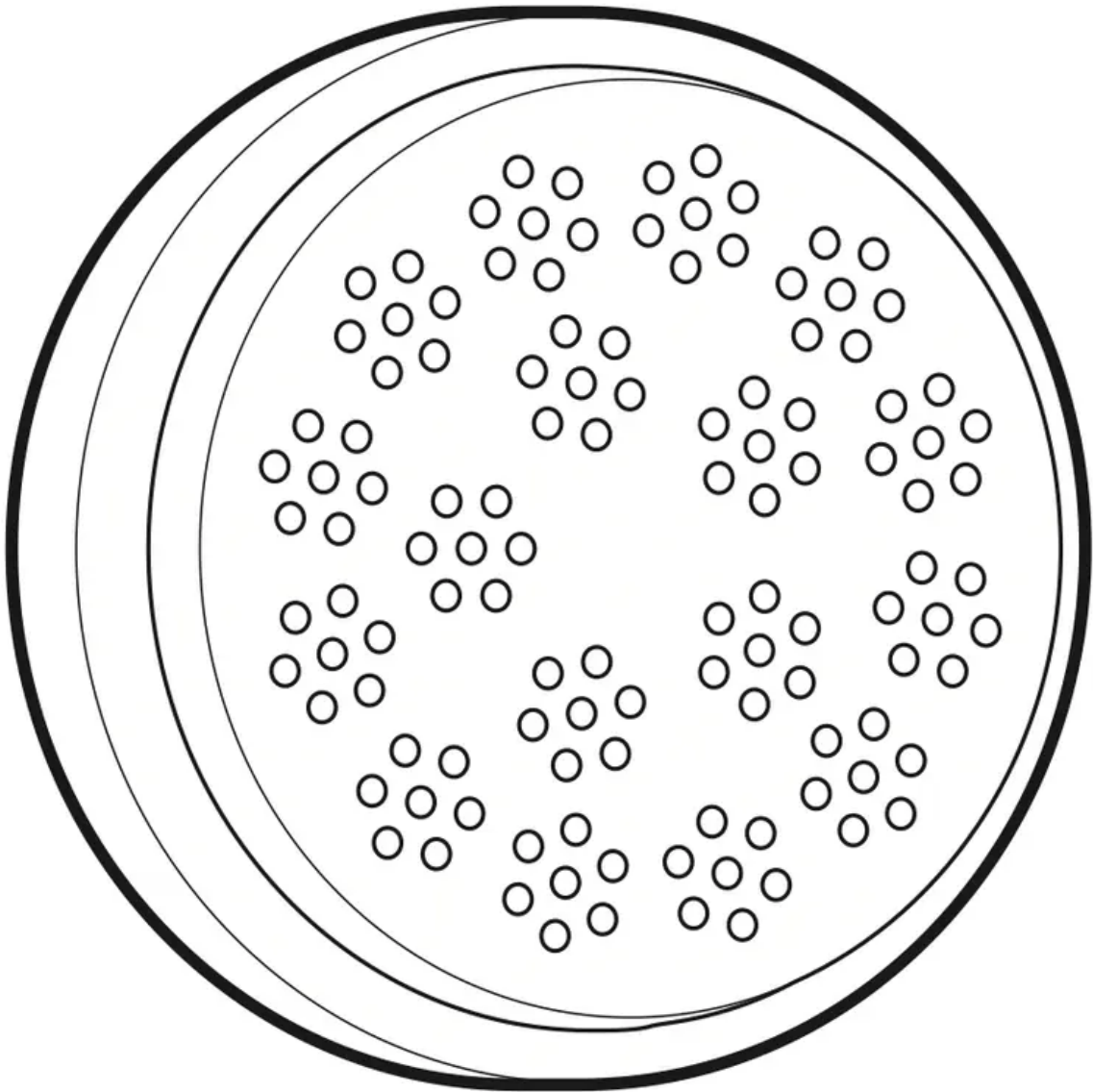

Angel Hair



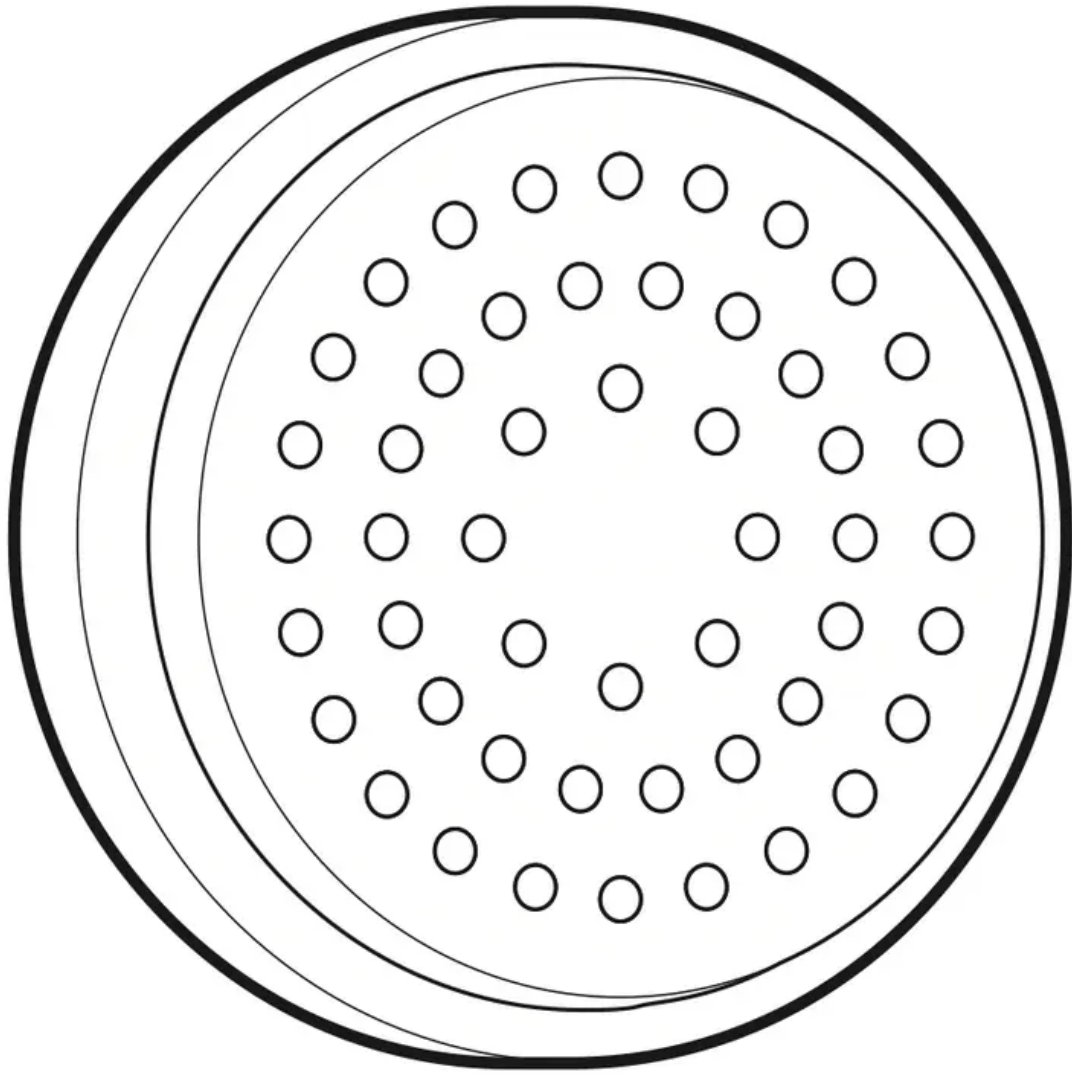

Spaghetti

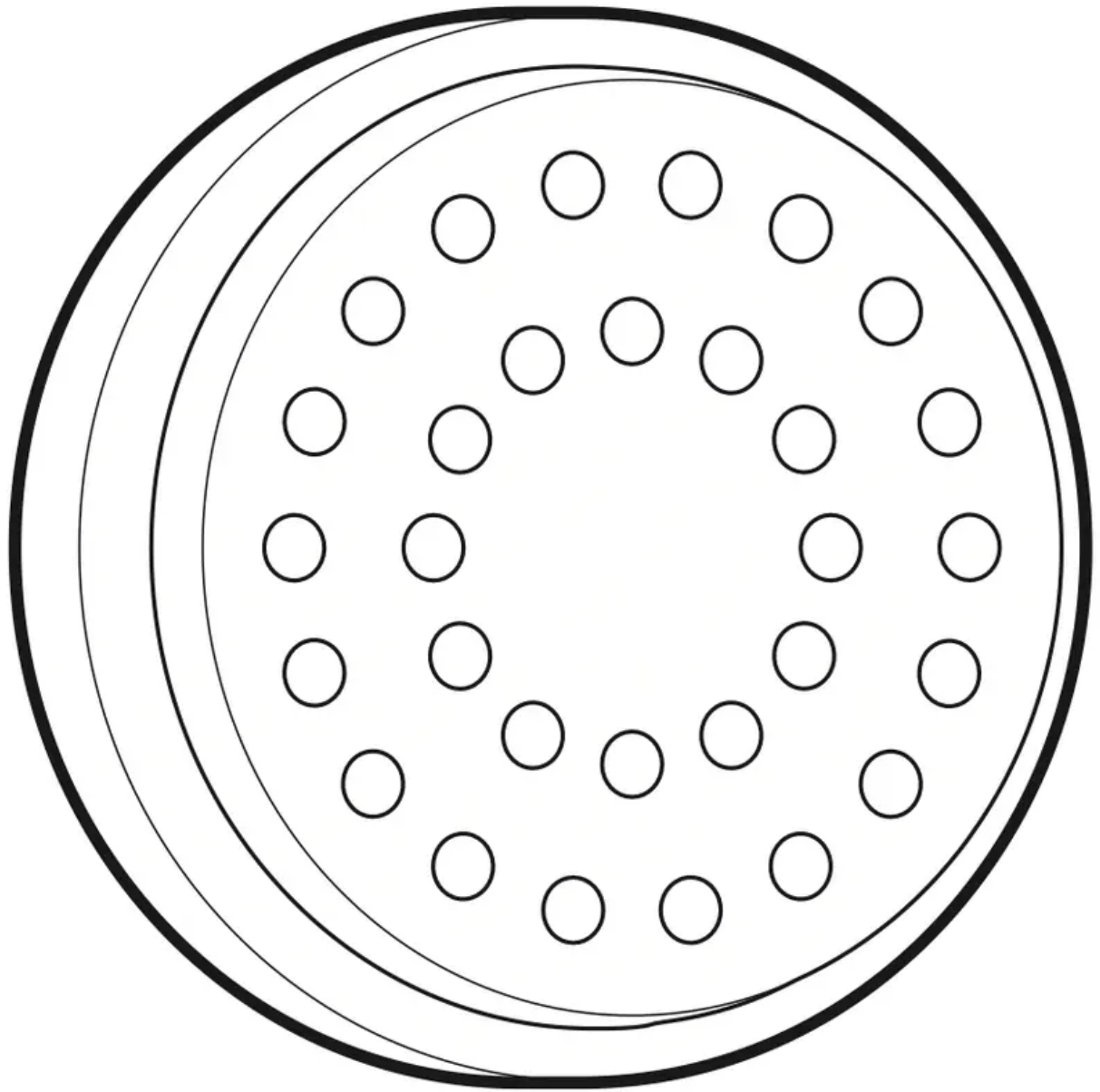

Thick Spaghetti

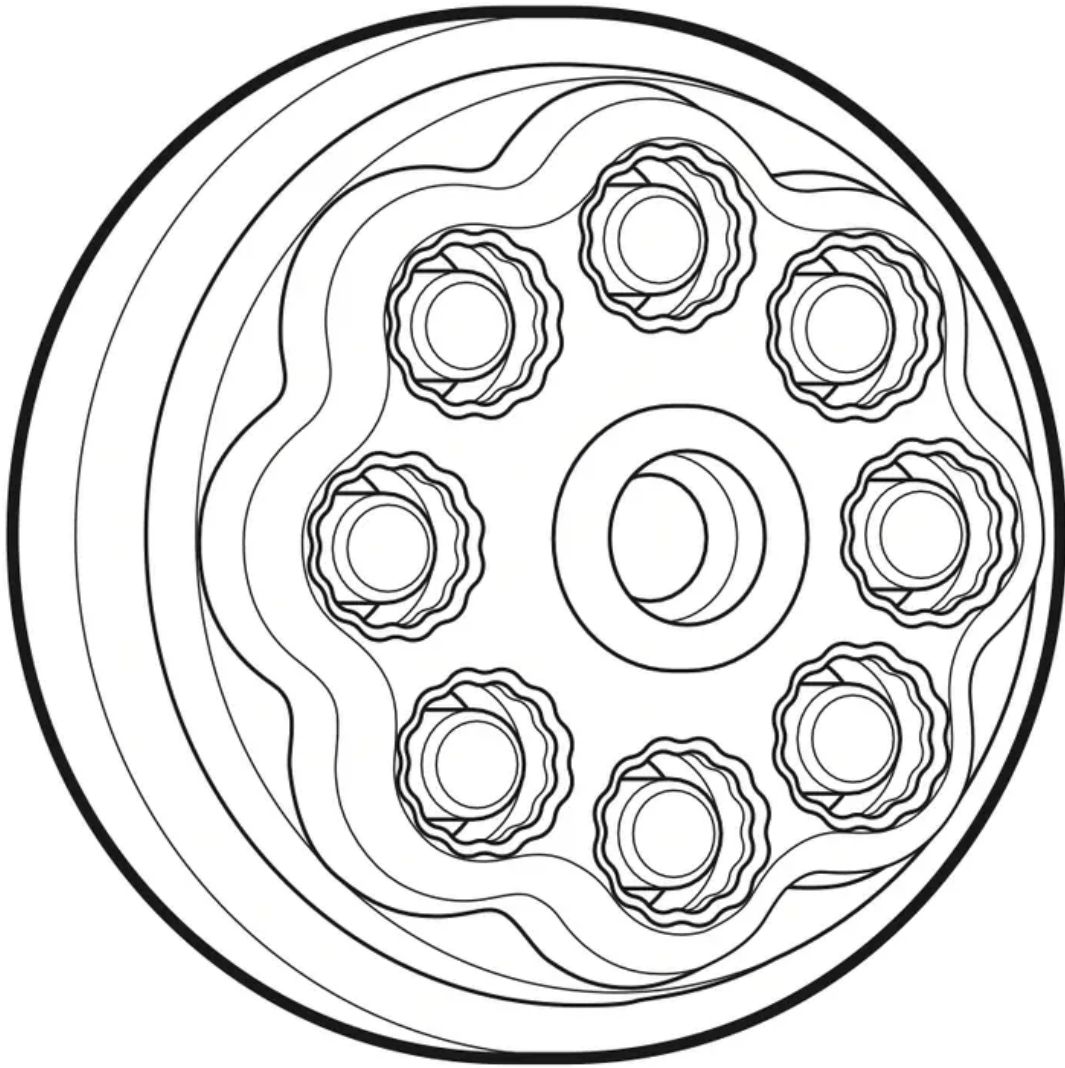

**Penne (2-Piece Disc)**

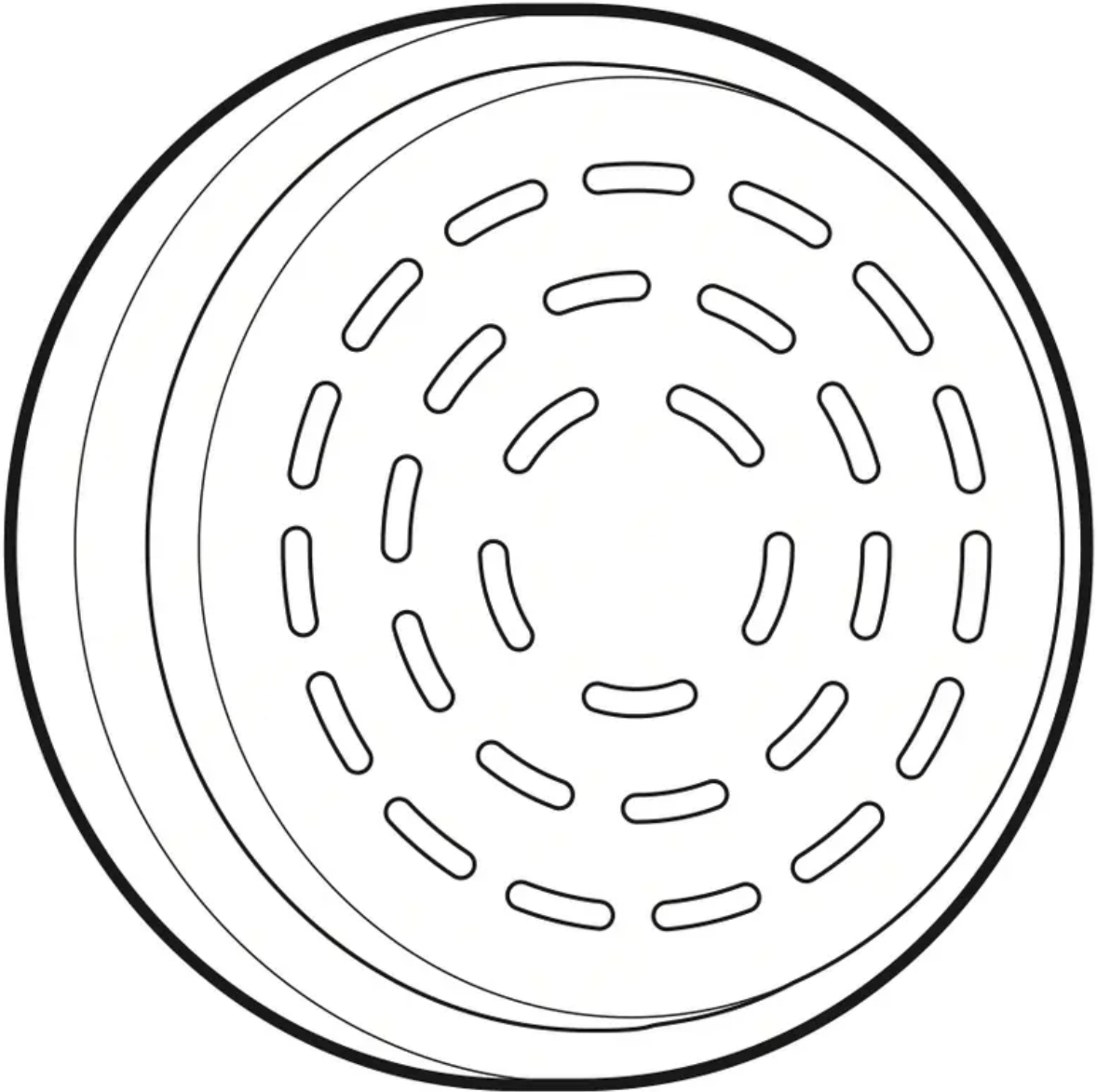

Fettuccine

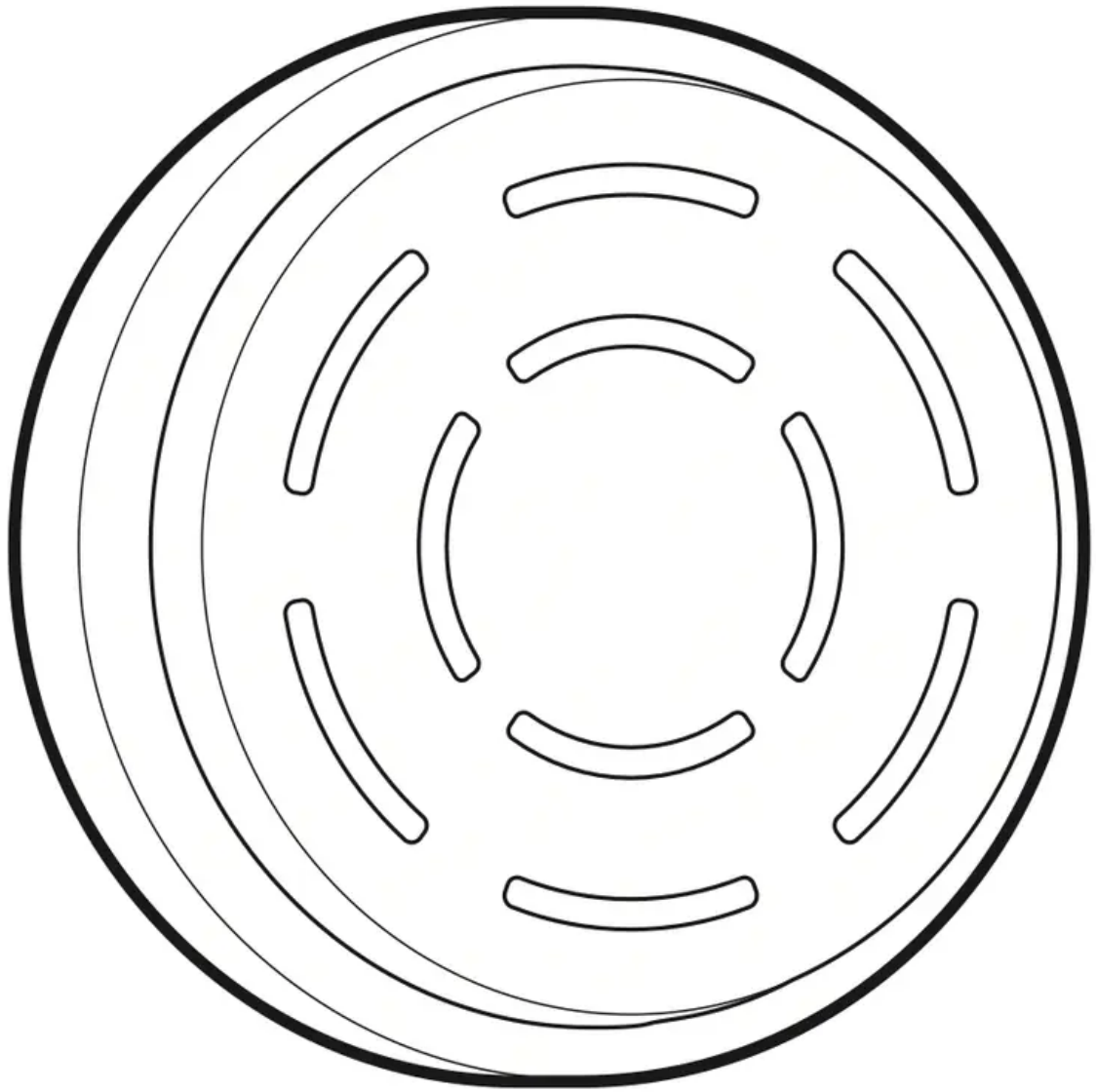

**Wide Noodle**

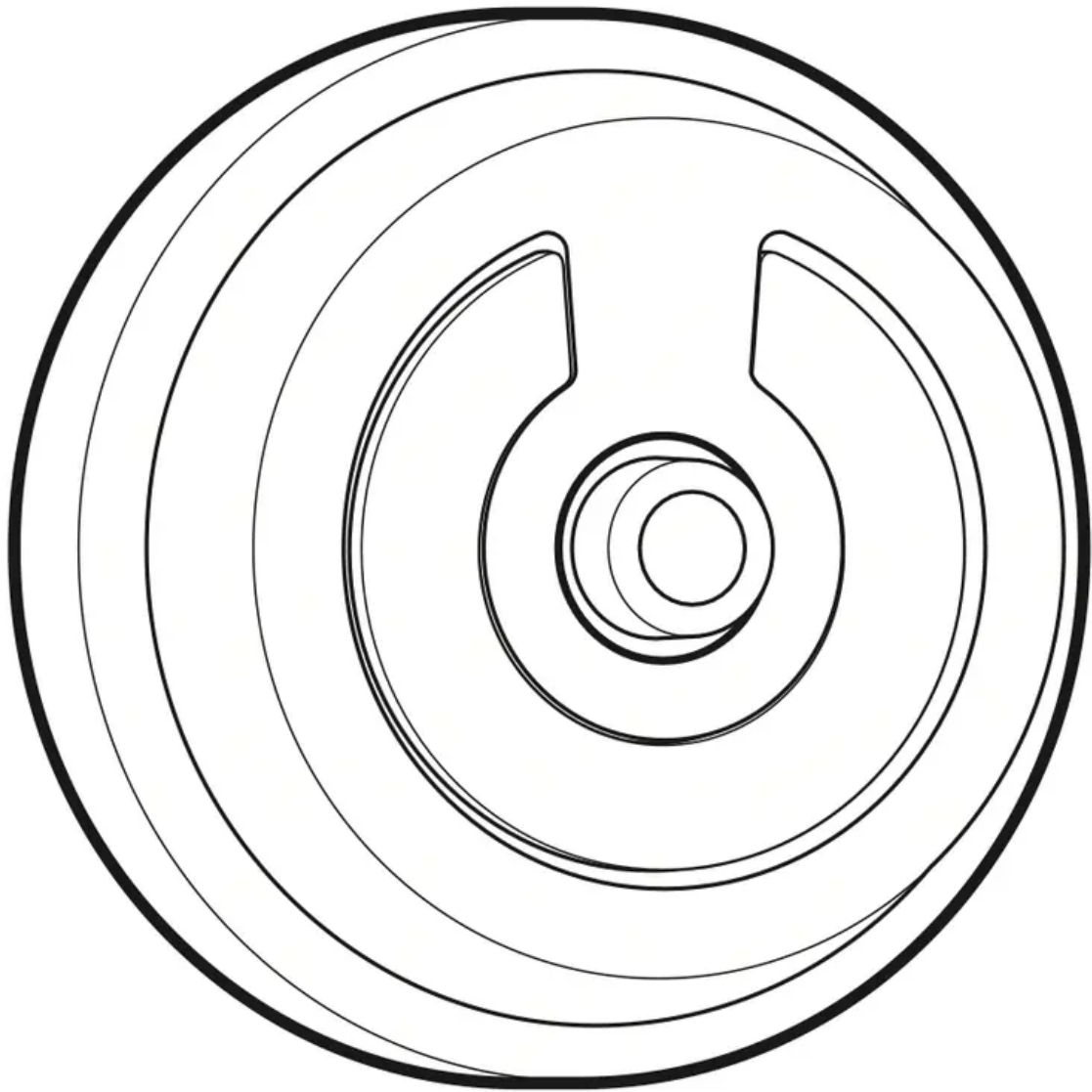

**Lasagna (2-Piece Disc)**

## Control Panel

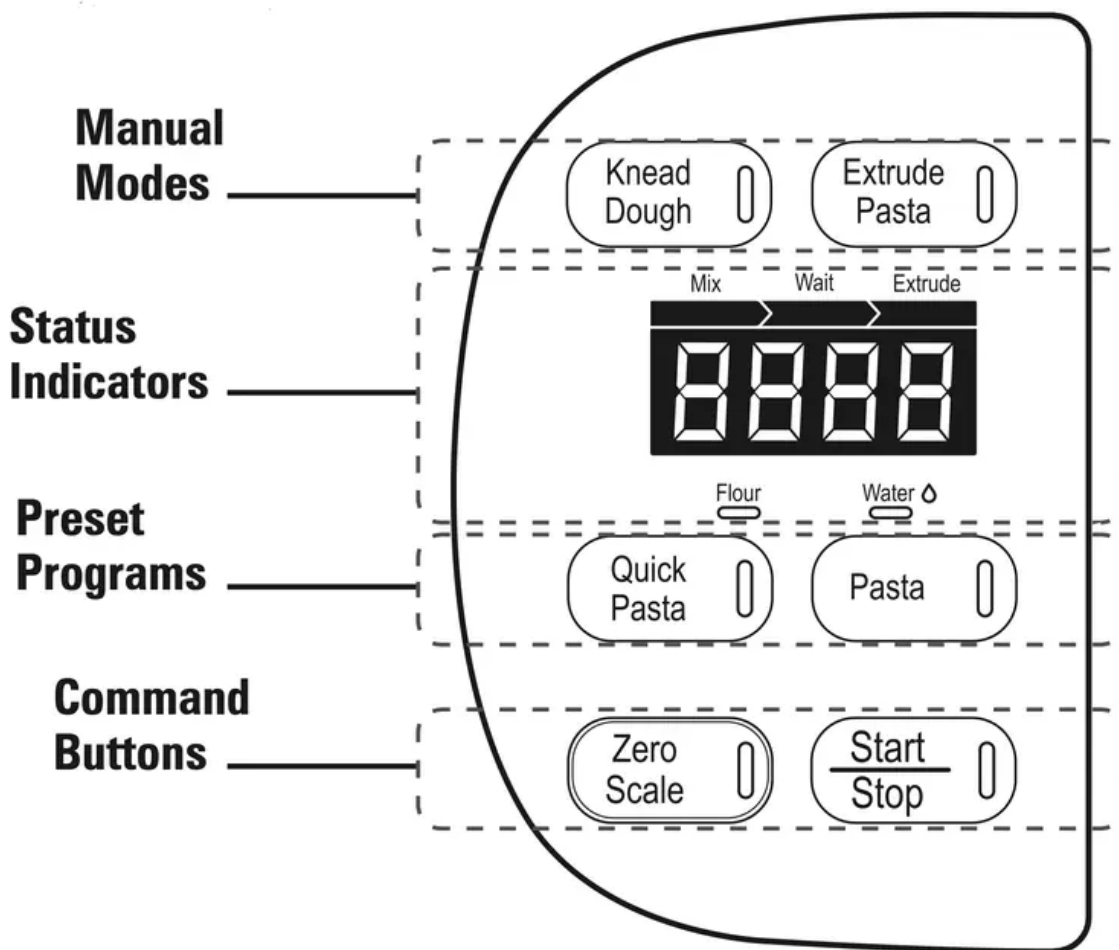

### Manual Modes

- Knead Dough – Use to mix ingredients.
- Extrude Pasta – Use to extrude noodles through Shaping Disc.

### Status Indicators

- Progress Bar – The progress bar will illuminate according to the stage.
- Digital Display – Displays weight of dry ingredients, amount of liquid to be added, and kneading time remaining.
- Flour (g), Water (ml) – The light below the word will illuminate to indicate which ingredient's measurement is being displayed.

### Preset Programs

- Quick Pasta – Automatically mixes/kneads the ingredients before extruding, then stops when program is complete. Program takes 15–18 minutes.
- Pasta – Automatically mixes/kneads the ingredients and provides a rest period before extruding, then stops when program is complete. Program takes 20–30 minutes.

## Command Buttons

- Zero Scale – Tares (zeros) the integrated scale used to weigh the flour or other dry ingredients.  
**NOTE:** Scale measures in grams only.
- Start/Stop – Press to start or stop the Pasta Maker.

## Using the Pasta Maker

1. With the Mixing Bowl removed from the base, insert the Mixing Paddle into the bowl, extending the metal end through the opening at the rear of the bowl.

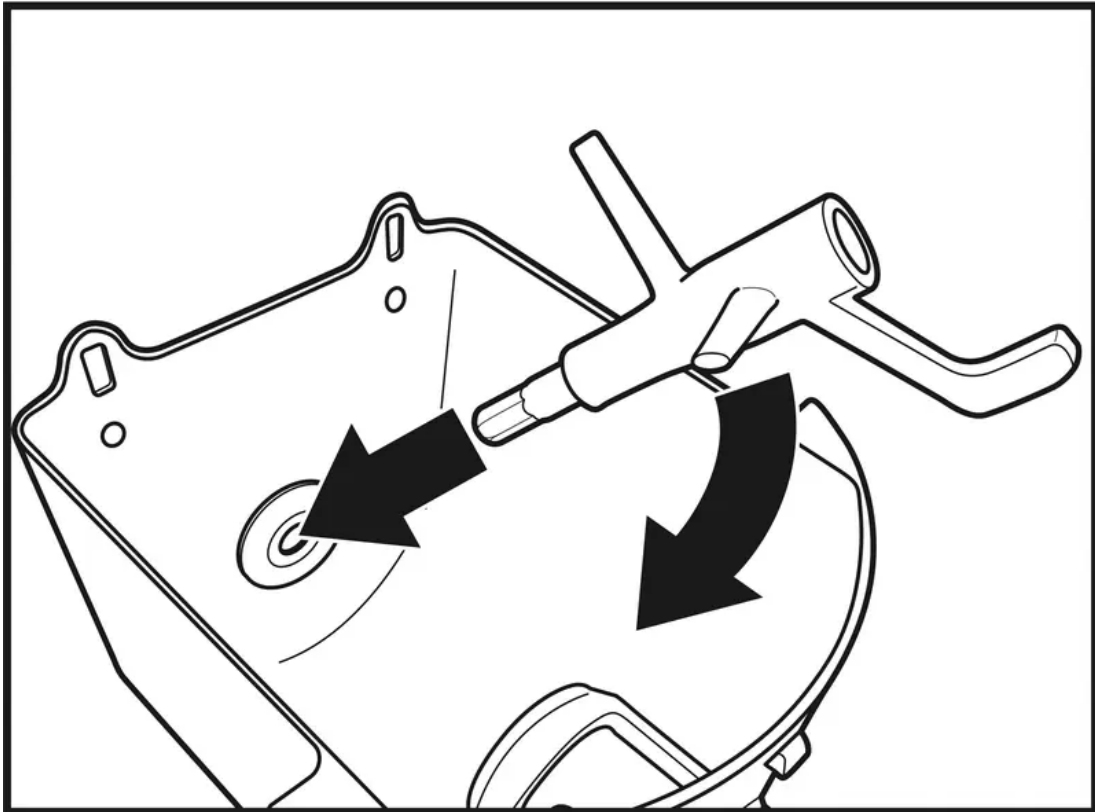

2. Slide the Mixing Bowl onto the base, aligning the Mixing Paddle with the Drive Coupler. You may need to slightly rotate the Mixing Paddle for the Mixing Bowl to slide in flush.

against the base.

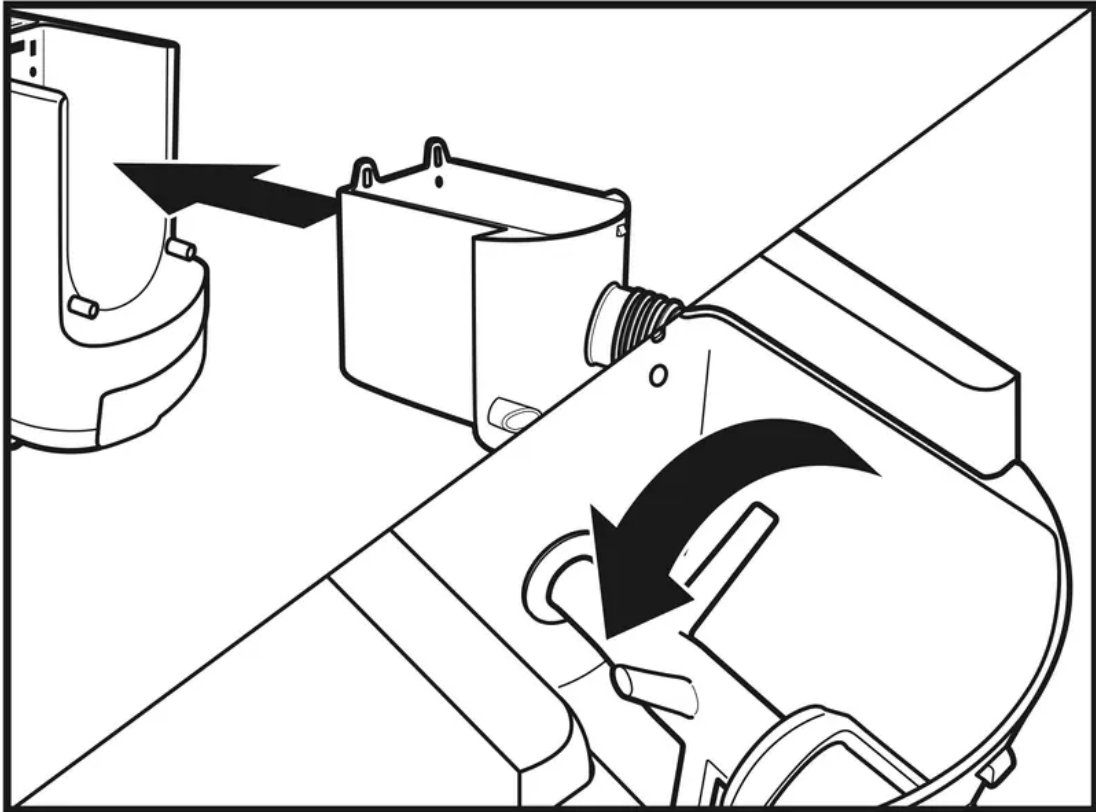

3. Insert Extruder, small end first, into the barrel end of the Mixing Bowl. Align the Extruder so that it fits into the end of the Mixing Paddle.

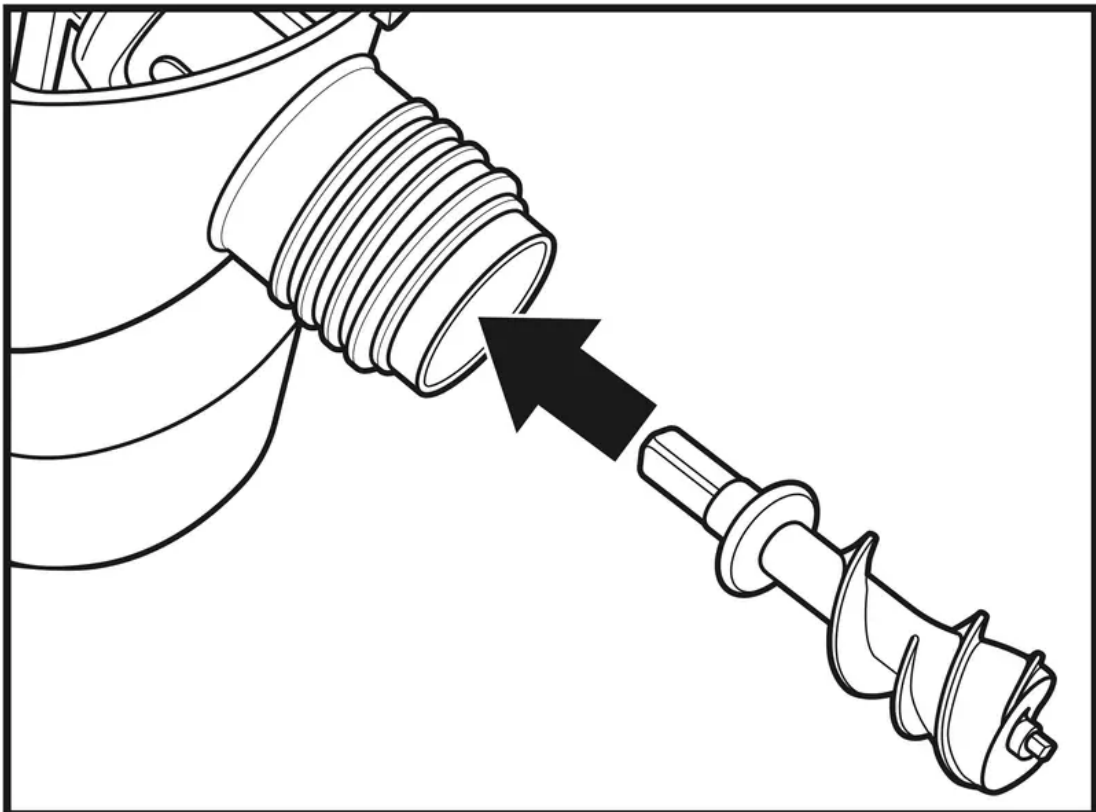

4. Select a Shaping Disc and position it on the barrel end, aligning the ribs on the barrel with the features on the disc. The ribs on the barrel prevent rotation of the disc during

extrusion.

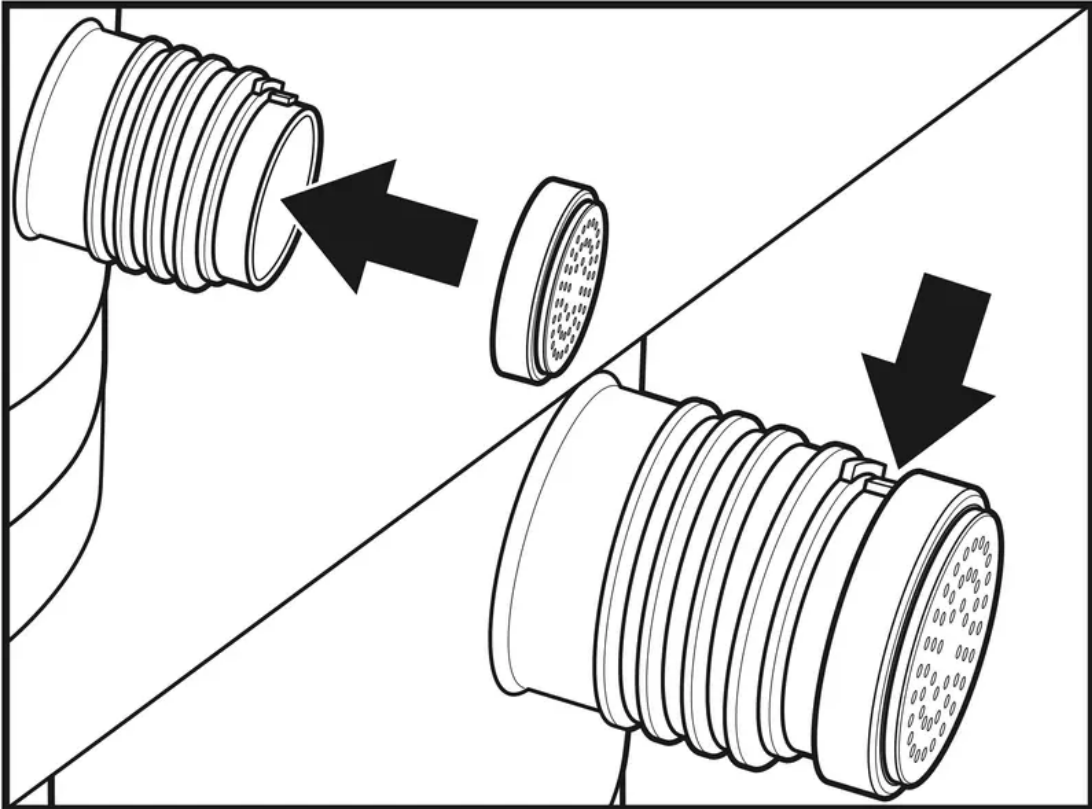

5. Hold the Shaping Disc in place while securing the Collar by rotating it clockwise.

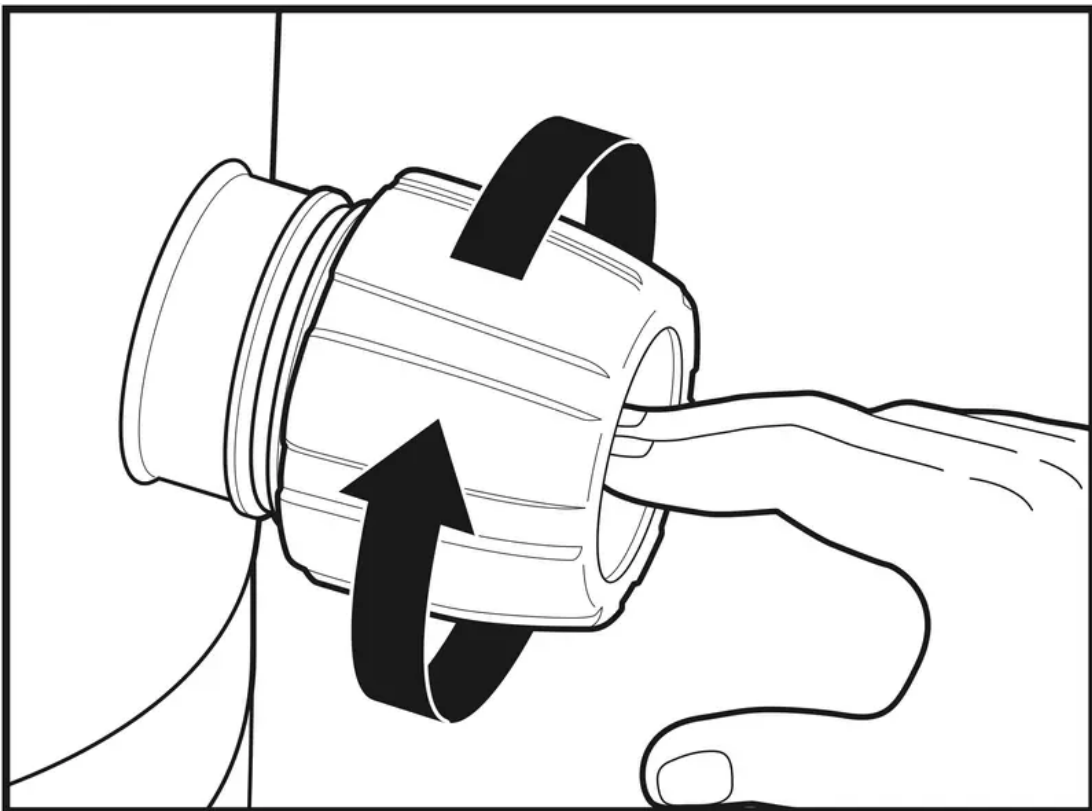

6. Plug into outlet; the Pasta Maker will chime once plugged in, and the Control Panel will light up.

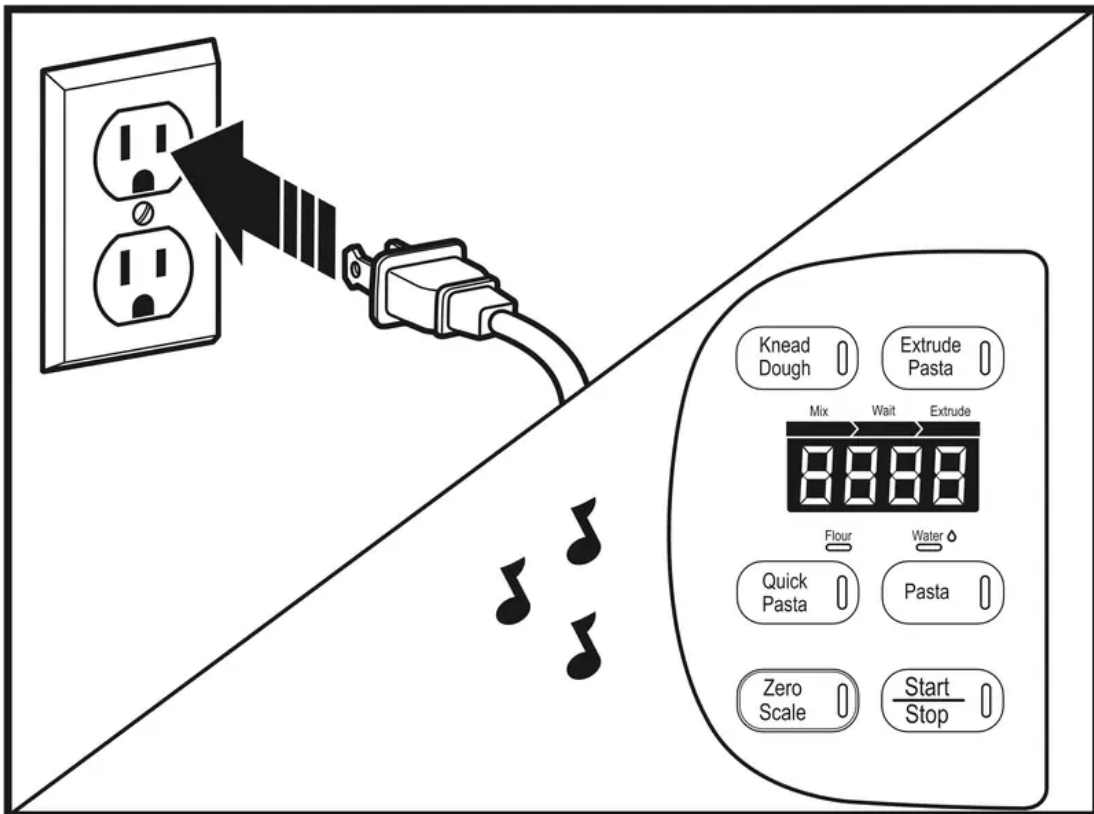

7. Press the ZERO SCALE button to tare the scale. The display will show "0" when taring is complete. Keep hands clear of Pasta Maker while zeroing the scale and adding dry ingredients.

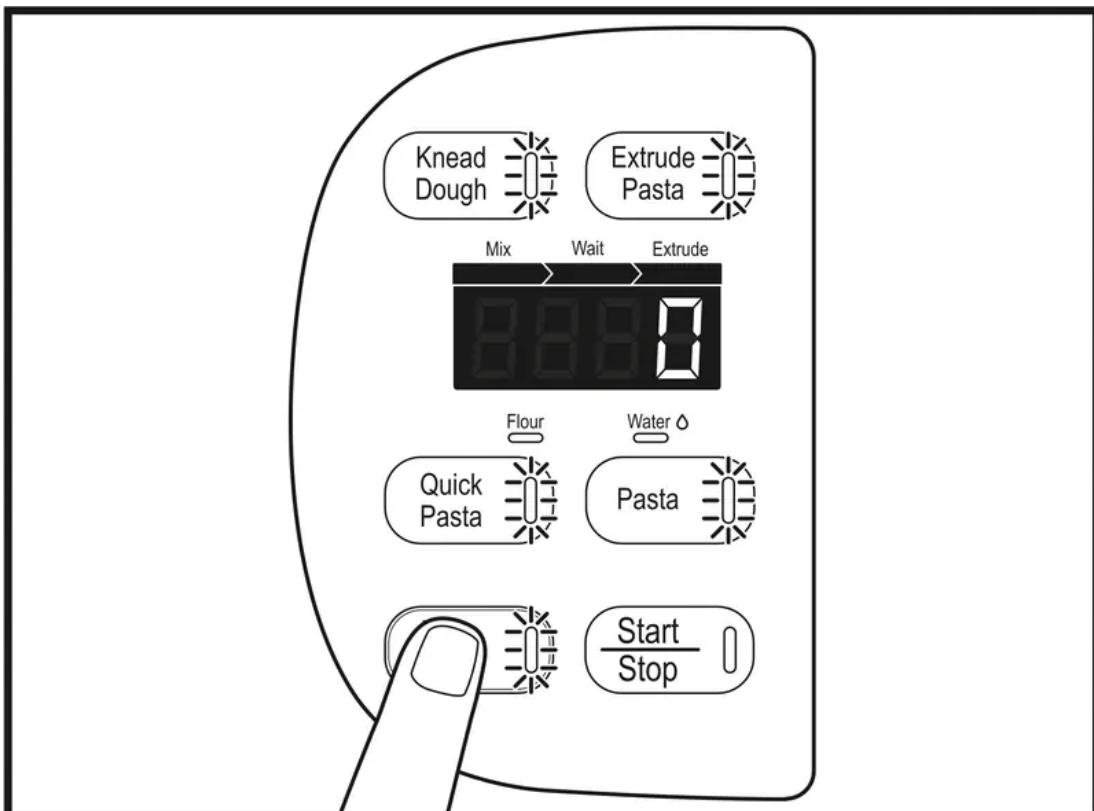

8. Add flour or other dry ingredients to the Mixing Bowl according to your selected recipe. The weight (in grams) of the ingredients will be displayed.

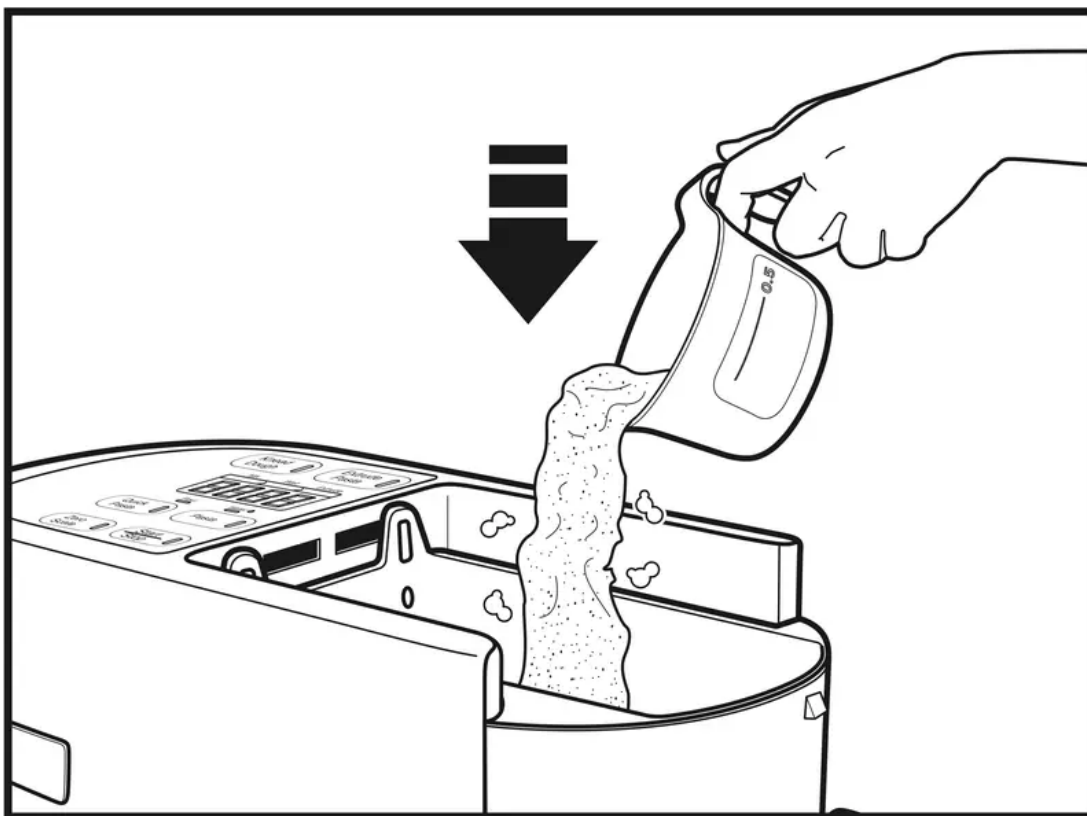

9. With the Mixing Bowl Lid at an angle, align the tabs at the end of the Lid with the slots on the base. Push down on the Lid until it snaps into place.

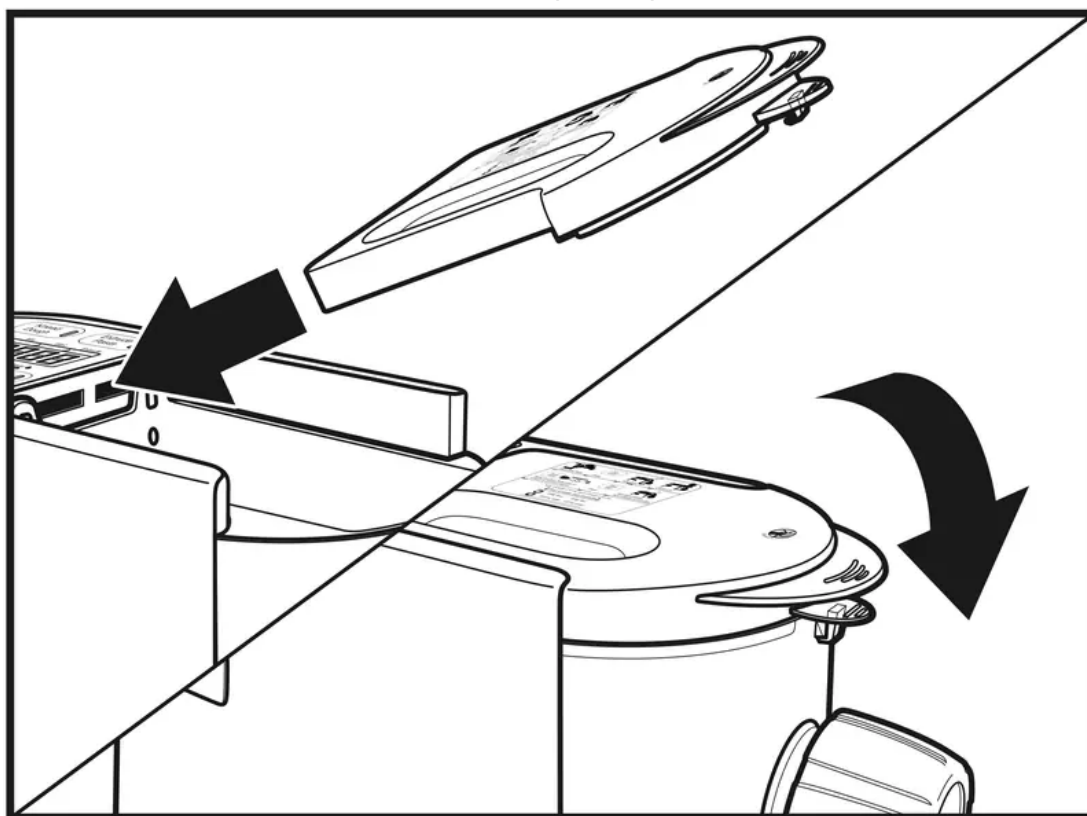

10. Select the desired program: Quick Pasta or Pasta.

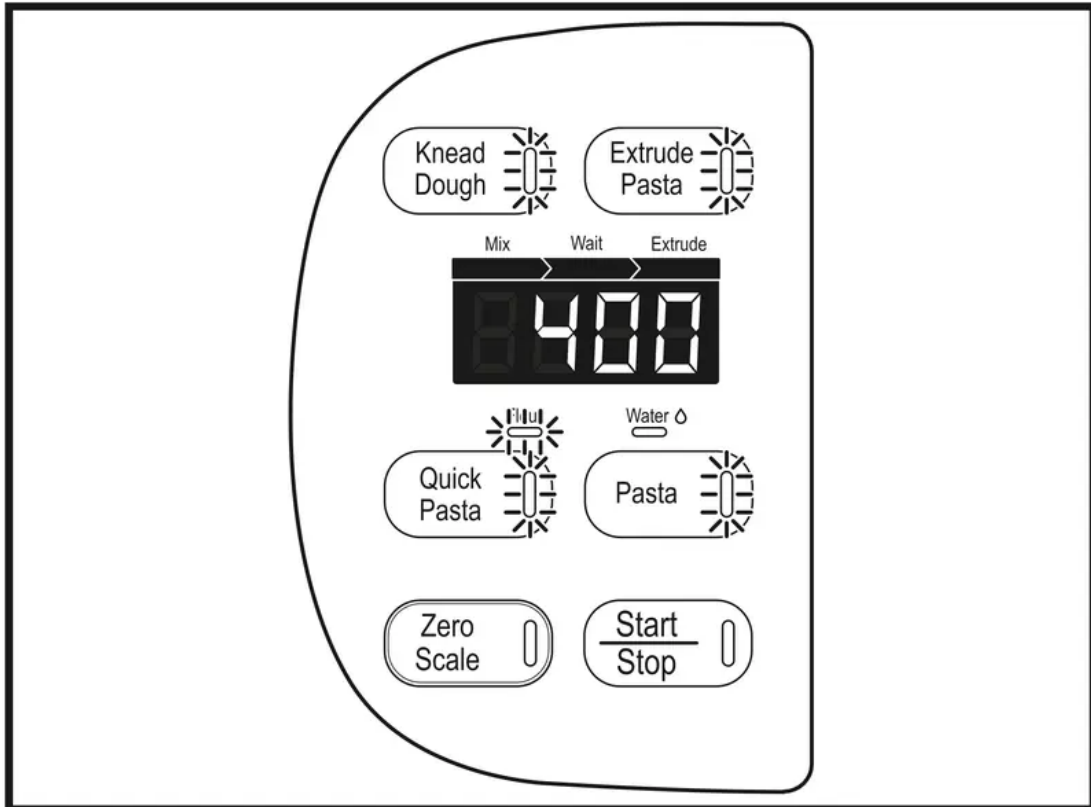

11. The display will indicate the amount of liquid in milliliters (ml) to add to the Mixing Bowl.

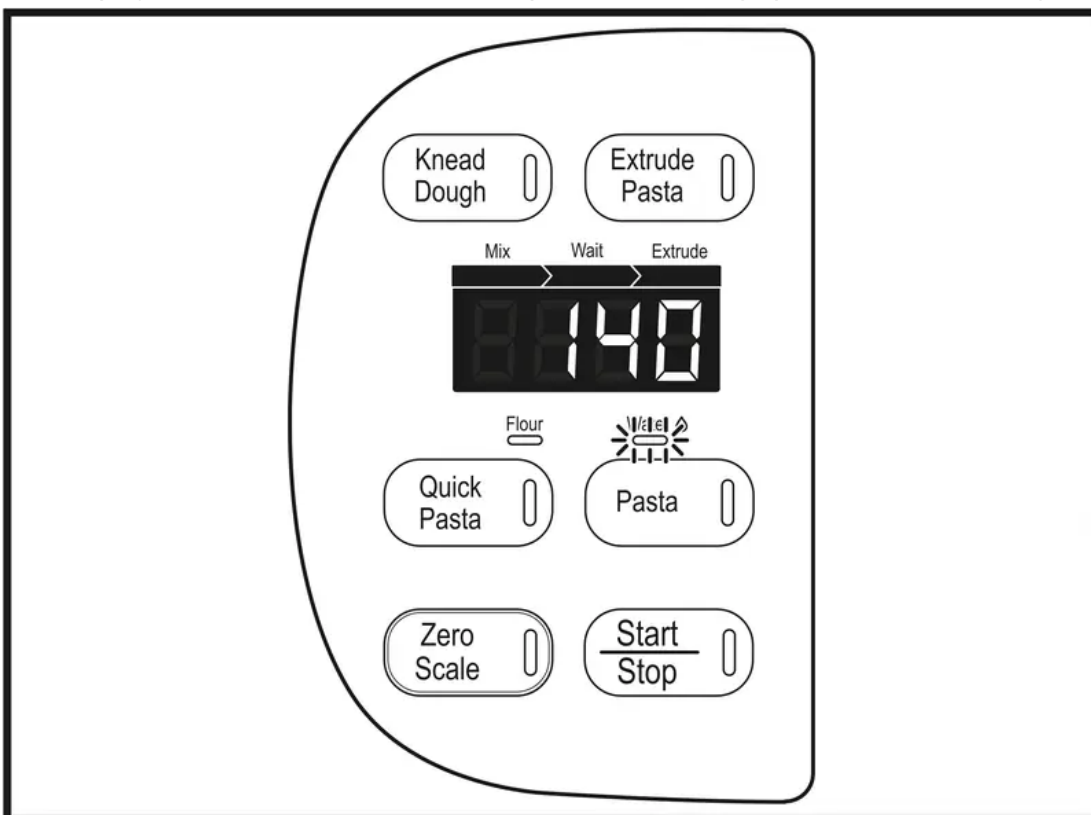

12. Press the START/STOP button.

Slowly pour the liquid from the measuring cup through the Liquid Well in the Lid. Use a

spatula to push any remaining egg through Liquid Well.

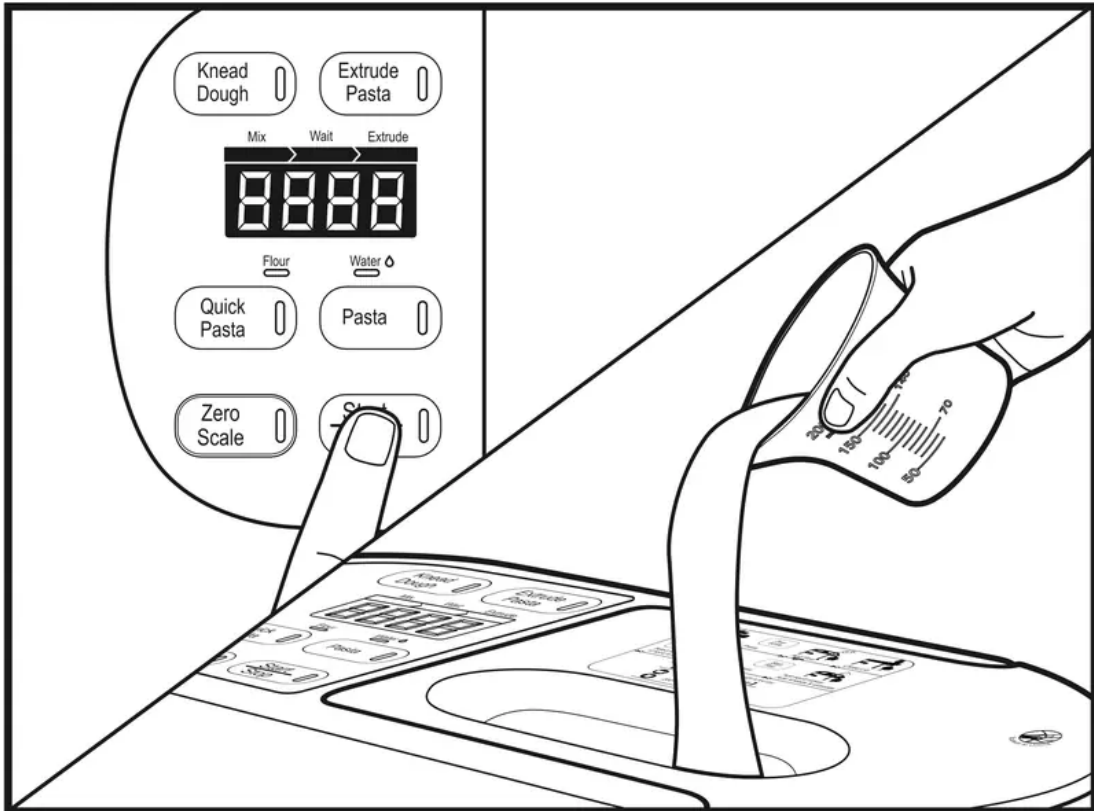

13. Cut pasta to desired length as it extrudes. After all pasta is extruded, the Pasta Maker will stop automatically. Unplug from outlet before removing or cleaning parts.

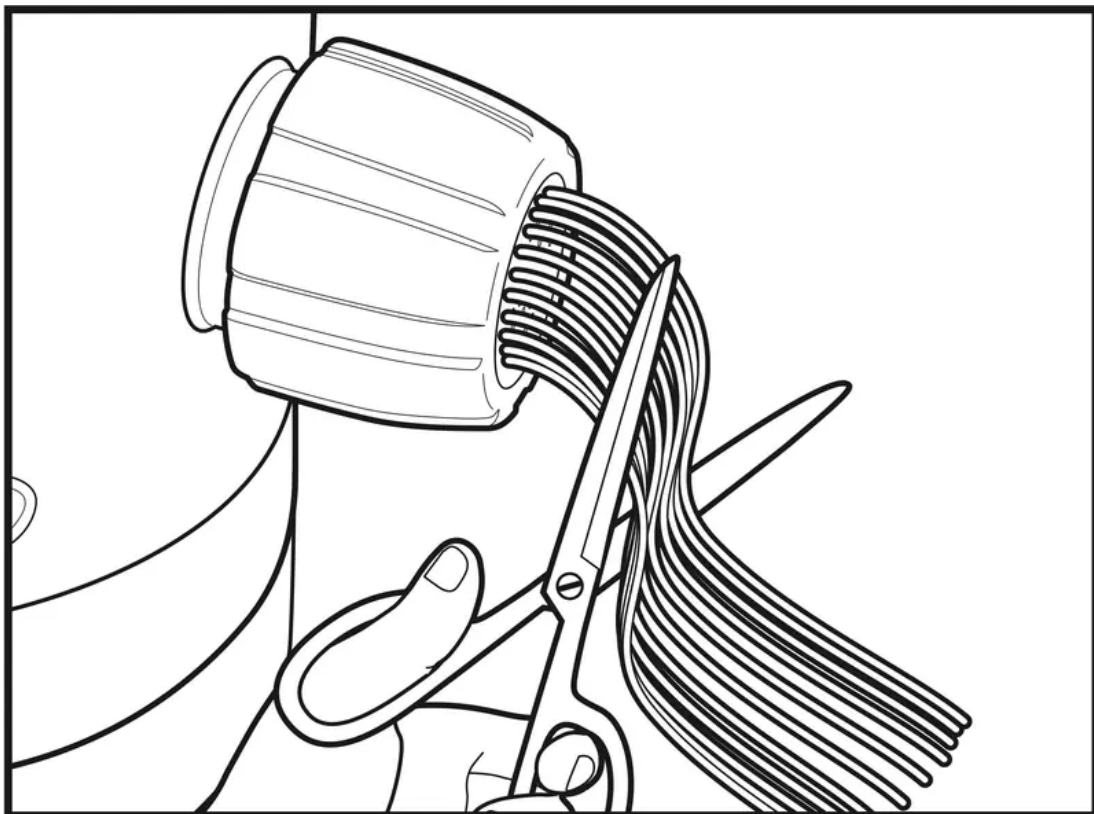

**NOTES:**

- Once pasta is extruded, either cook pasta immediately, store in an airtight container in refrigerator for up to 3 days, or store in a freezer-safe container in the freezer for up to 3 months.
- To cook pasta, cook in salted boiling water until it floats, then check for doneness.

**To measure the liquid amount using the provided measuring cup:**

1. Break any eggs into the cup and beat the eggs until smooth.
2. Add water, juice, or purée to the measuring cup until the amount indicated on the display is reached.

**NOTE:** The liquid volume measurement displayed on the scale will NOT change as the liquid is poured into the Pasta Maker.

**When using the preset programs:** The Pasta Maker will automatically extrude the pasta through the Shaping Disc.

**When using the manual mode:** Kneading will stop automatically after 5 minutes. You can stop kneading at any time by pressing the Start/Stop button. Press the EXTRUDE PASTA button when ready to extrude.

## Care and Cleaning

### **WARNING - Electrical Shock Hazard.**

Disconnect power before cleaning. Do not immerse cord, plug, or base in any liquid

1. Unplug. Remove Collar by turning counterclockwise, then remove Shaping Disc.

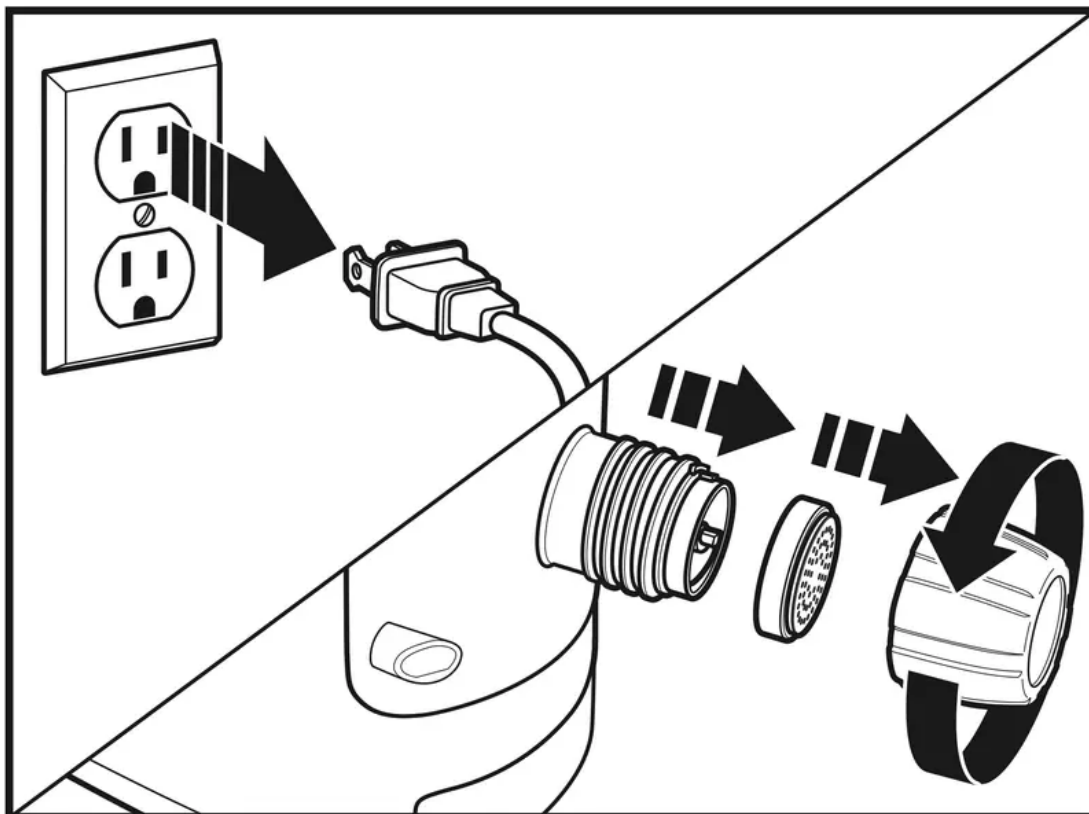

2. Open Lid and remove.

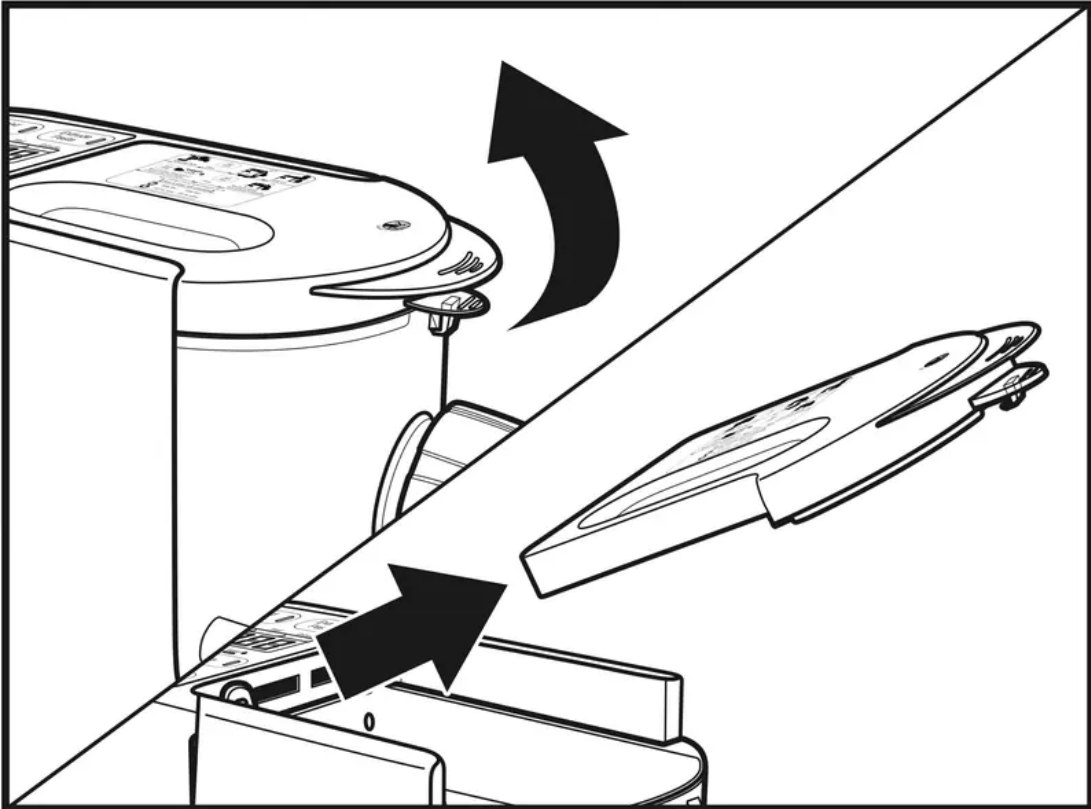

3. Remove Extruder by pushing it out of the barrel with your thumb, then pulling it out the rest of the way from the front of the bowl.

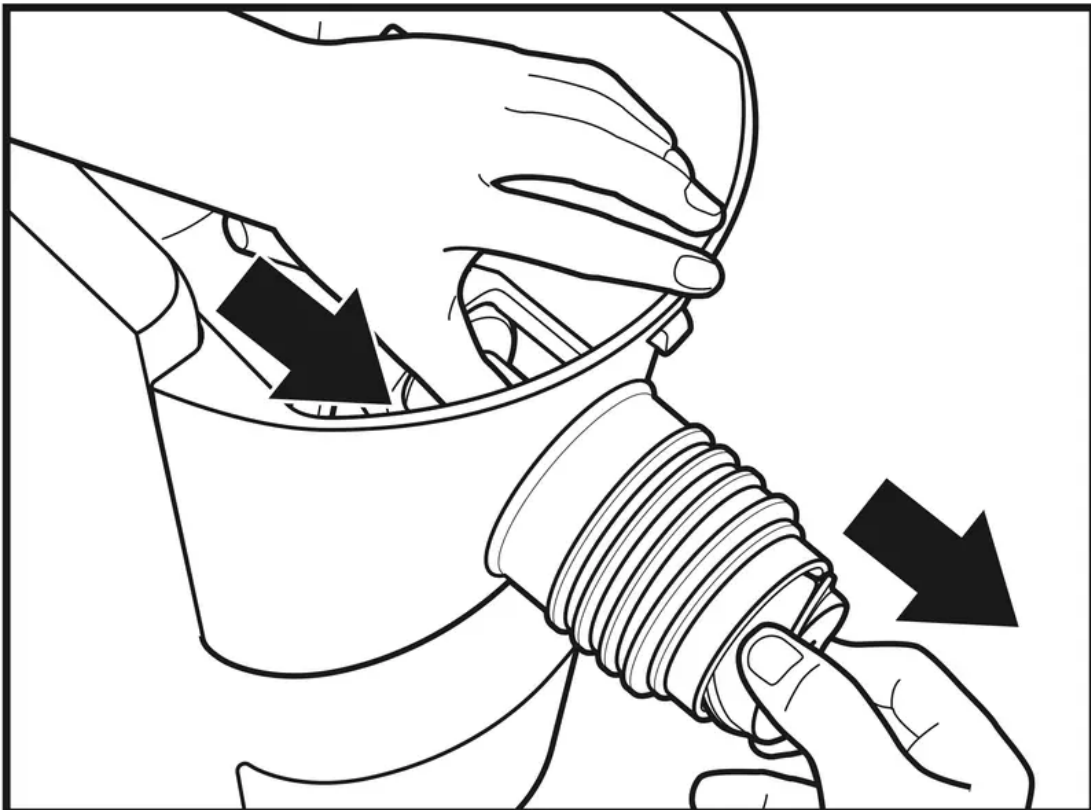

4. Slide Mixing Bowl away from base, then remove Mixing Paddle.

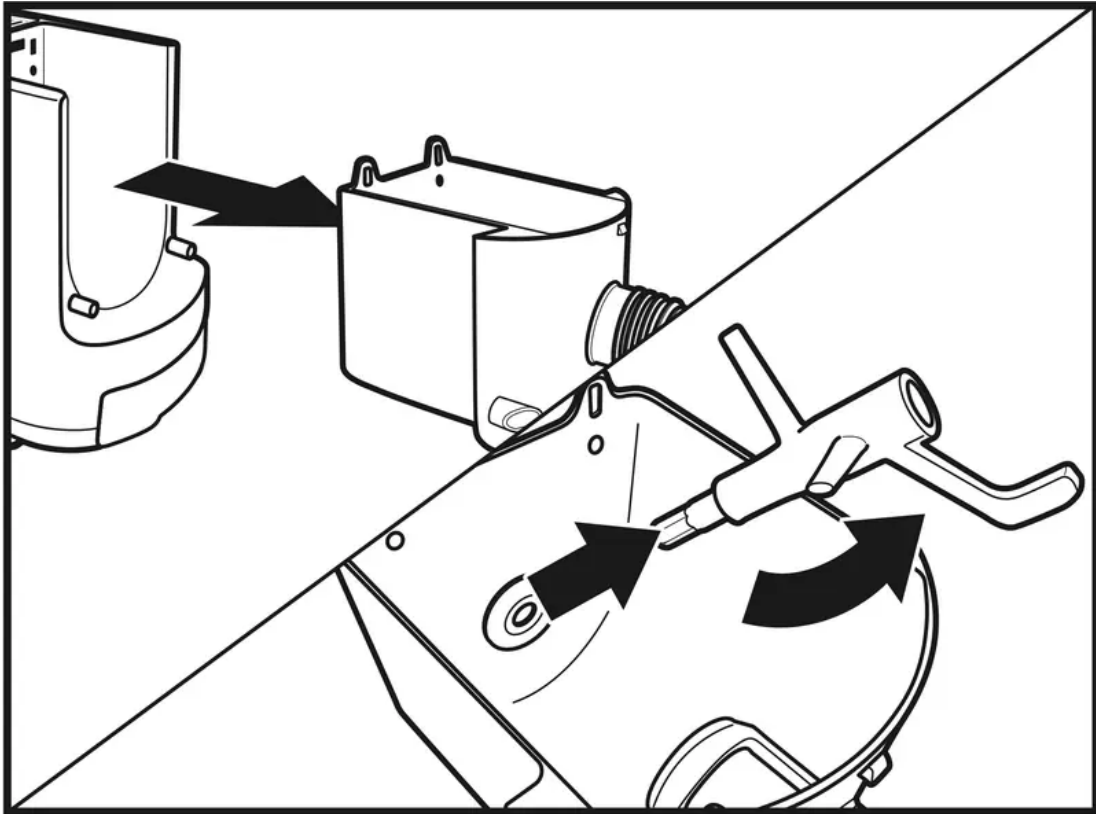

5. Use the cleaning tool to poke out any remaining pieces of dough from the Shaping Disc.

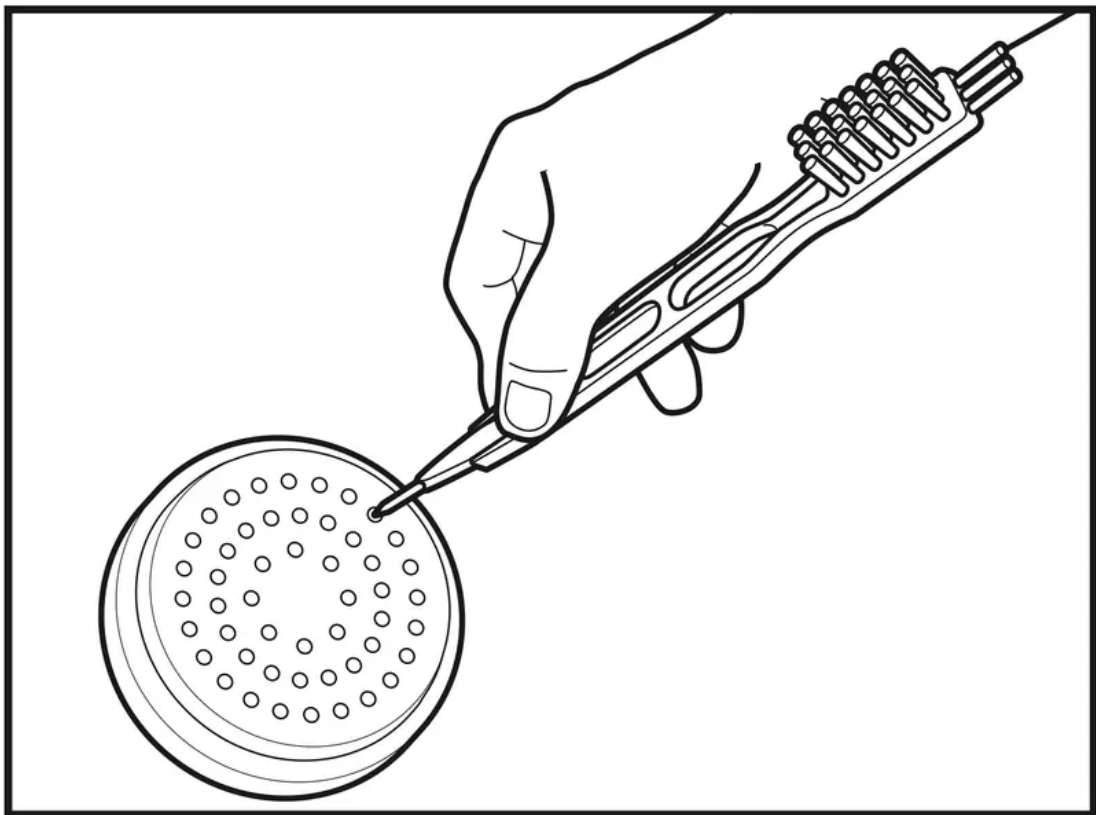

**TIP:** For easier cleaning, allow the dough to dry before using the cleaning tool. If dough will not come out easily, place disc in the freezer for 30–60 minutes, then try again.

6. Wash the removable parts in hot, soapy water. Rinse and dry thoroughly before storing, or wash in the top rack of the dishwasher. Wipe base with a soft damp cloth, then dry.

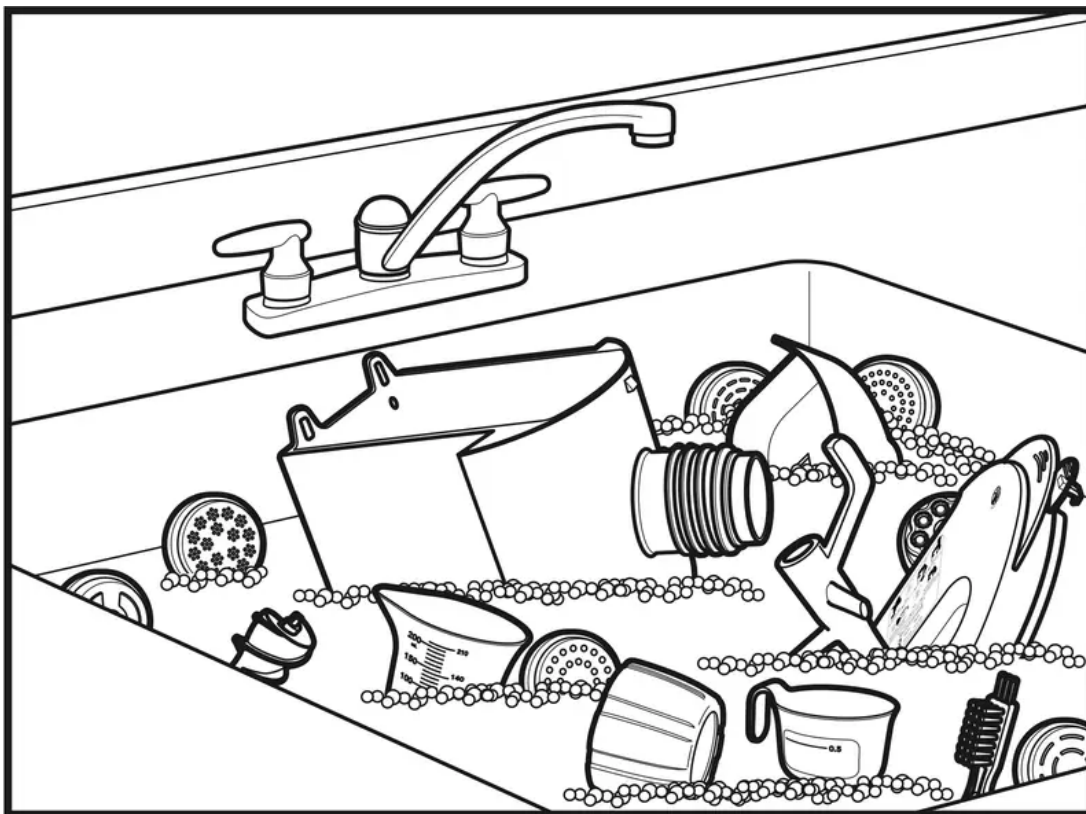

7. Store the Shaping Discs in the Storage Drawer located at the bottom of the base.

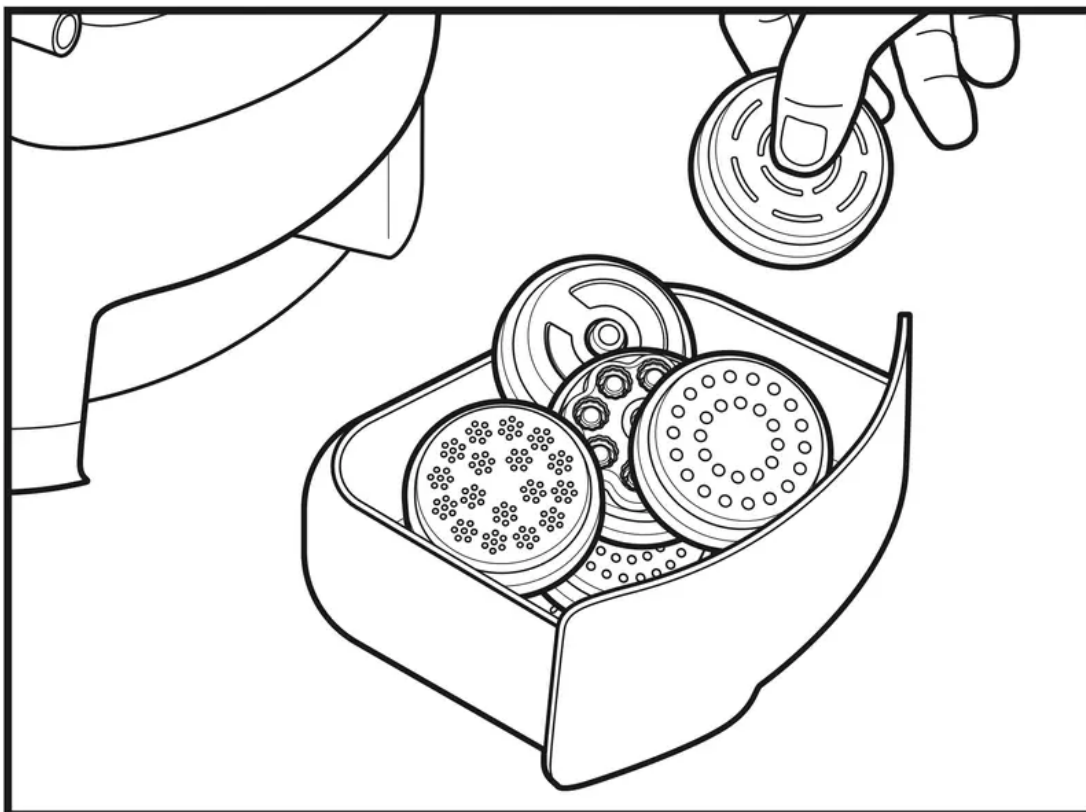

## Troubleshooting

The Pasta Maker may display an error message from time to time. Use the table below to quickly resolve the issue.

Error Code	Situation	Solution
E02	Mixing bowl Lid is not in place.	Make sure Lid is snapped onto Mixing Bowl.
E14	Too much flour in the Mixing Bowl.	Remove some flour from Mixing Bowl.
E16	No liquid in the Mixing Bowl.	Add correct amount of liquid.
E04, E05, E09, E15, E17	Call Customer Service at 1.800.851.8900.	
none	Dough is too wet.	<ol style="list-style-type: none"> <li>1. Press START/STOP button and unplug.</li> <li>2. Remove Lid and break up any clumps or balls of dough with your hands.</li> <li>3. Add 2 tablespoons (30 ml) of flour to dough, then replace Lid and plug back in.</li> <li>4. Press KNEAD DOUGH, then START/STOP button.</li> <li>5. Repeat as necessary for desired consistency.</li> </ol>
none	Dough is too dry.	Add 5–10 ml liquid and continue to mix. Press KNEAD DOUGH button, if necessary.

### If the Pasta Maker stops working:

- Unplug.
- Wait 5 seconds, and then plug back into outlet.
- Use Manual Mode to finish kneading or extruding pasta.

**Warning**

This content is compiled from multiple sources and is provided for reference purposes only. It may not be complete or fully applicable to all situations. If you are unable to resolve your issue, please contact the product manufacturer or an authorized service provider for official support.

---

Document generated by [ManualsFile](#)