

Overview

Layout

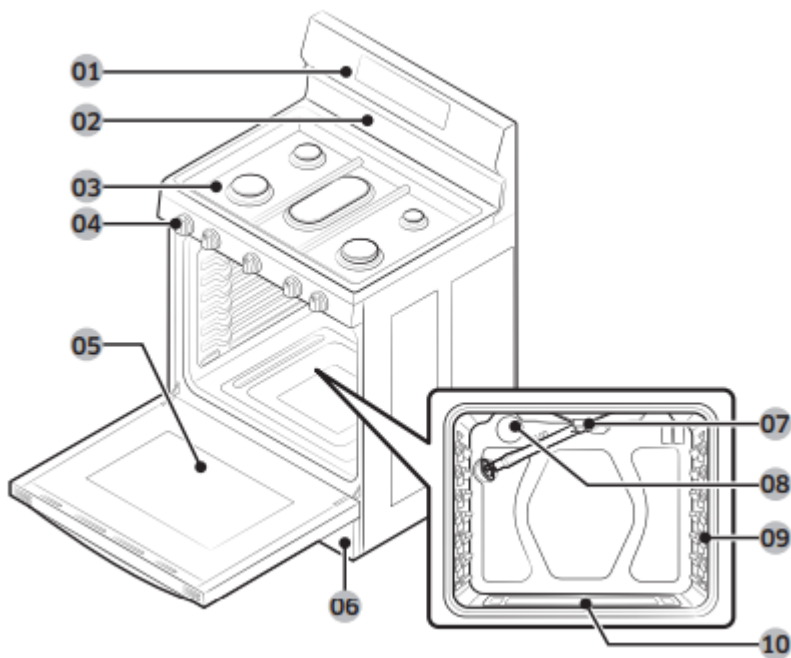

- 01 Display
- 02 Oven vents
- 03 Surface burners
- 04 Surface burner knobs (5 pcs)
- 05 Removable oven door
- 06 Storage drawer
- 07 Broil oven burner
- 08 Oven light
- 09 Oven rack system
- 10 Bake oven burner



Surface burner
grates (2) * and
griddle (1) *



Surface burners and
caps (5) *



Flat rack (2) *

NOTE If you need an accessory marked with an asterisk (*), you can buy it from the Samsung Contact Center (1-800-SAMSUNG (726-7864)).

Control panel

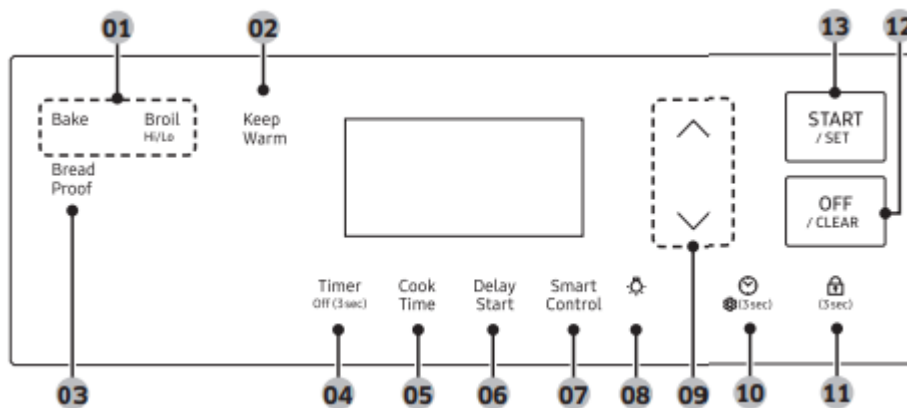

01 Oven modes: Activates each oven mode (Bake or Broil).

02 Keep Warm: Keep cooked food warm at lower temperature at 175 °F (80 °C).

03 Bread Proof: Activates the Bread proof function.

04 Timer: Activates or deactivates the timer.

05 Cook Time: Set the cooking time.

06 Delay Start: Set the oven to start at a certain time.

07 Smart Control: Activates the Wi-Fi connection.

08 Oven Light: Turn on/Turn off the oven light.

09 \wedge / \vee (Up/Down): Use to set the times, or temperatures.

10 Clock: Set the clock time.

11 Lock: Press and hold for 3 seconds to lock the control panel and the door to prevent accidents.

12 OFF/CLEAR: Cancel the current operation but not the timer.

13 START/SET: Start a function or set the time.

Before you start

You should know about the following features and components before you use your range for the first time.

Clock

You must set the clock correctly to ensure the automatic features work properly.

To set the clock time

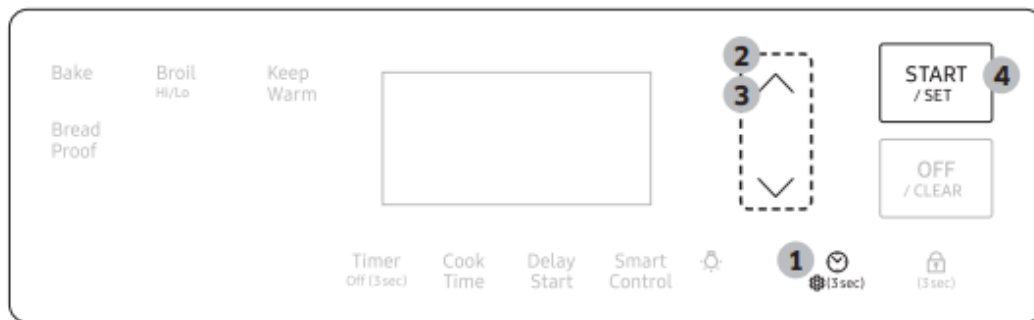

1. Press .
2. Set the hours using \wedge and \vee . Then, press START/SET to confirm the hours.
3. Set the minutes using \wedge and \vee .
4. Press START/SET to confirm the settings.

Oven vent/cooling vent

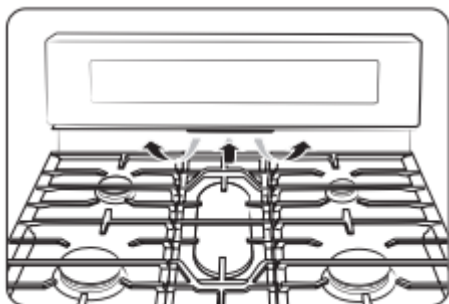

The oven vent is located under the oven Control panel. Proper air circulation prevents oven burner combustion problems and ensures good performance.

- Do not block the vent or its surroundings.
- Use caution when placing items near the vent. Hot steam can cause them to overheat or melt.

Gas oven



STEP 1 Put all ingredients in a heat-safe container.



STEP 2 Select a cooking mode, and then start preheating.



STEP 3 Place the container on a rack.

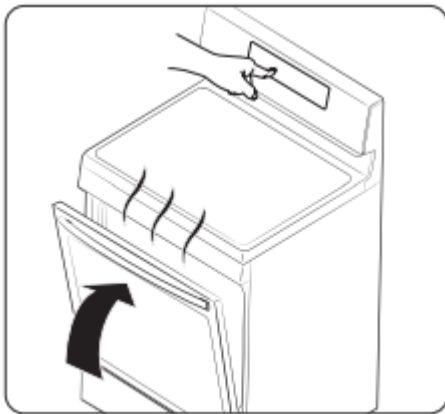

STEP 4 Close the door and start cooking.

NOTE

- The cooling fan automatically runs for a certain amount of time after cooking is complete.
- There can be a slight popping sound during oven cooking. This sound may occur during normal oven burner cycling, when the oven burner flame is extinguished.

Cooking options

CAUTION Food that can easily spoil, such as milk, eggs, fish, poultry, and meat, should be chilled in a refrigerator before they are placed in the oven. Even when chilled, they should not stand for more than 1 hour before cooking begins and should be removed promptly when cooking is completed.

Timer

The Timer gives you an extra timer you can use to time cooking tasks such as boiling eggs. It does not, however, start or stop any cooking operation. You can set the timer from 1 minute to 9 hours and 59 minutes.



1. Press Timer Off (3sec).
2. Enter a desired time using the \wedge or \vee pad. If you press the pad constantly, you can move 10 minutes.
3. When done, press START/SET.
4. To cancel the Timer settings, press and hold Timer Off (3sec) for 3 seconds.
5. When the set time elapses, the oven beeps and displays the “End” message. Press OFF/CLEAR or Timer Off (3sec) to delete the message.

NOTE To change the set time, press Timer Off (3sec), enter a different time, and then press START/SET.

Cook Time

Timed cooking sets the oven to cook foods at a set temperature for a set length of time. The oven automatically turns off when it finishes.

Mode: Bake



1. Press Bake.
2. If necessary, change the temperature using the \wedge or \vee .
3. Press Cook Time.

4. Set the cooking time between 1 minute and 9 hours and 59 minutes (9:59) using the \wedge or \vee .
5. Press START/SET. The oven will automatically turn on and start preheating. The temperature will increase until it reaches the temperature you set. The oven starts cooking for the amount of time you set.
6. When preheating is complete, put the container with the food on a rack, and then close the door.
7. When the cooking time has elapsed, the oven will automatically shut off and then beep.

NOTE

- To change the programmed cooking time, press Cook Time, enter a different time, and then press START/SET.
- If necessary, press Keep Warm after setting the cooking time. Then, Keep Warm will start when the cooking time has elapsed.

Delay Start

The Delay Start function lets you use the kitchen timer to automatically start and stop another cooking program. You can set Delay Start so that it delays the automatic start of a cooking operation you select by up to 12 hours.

Mode: Bake

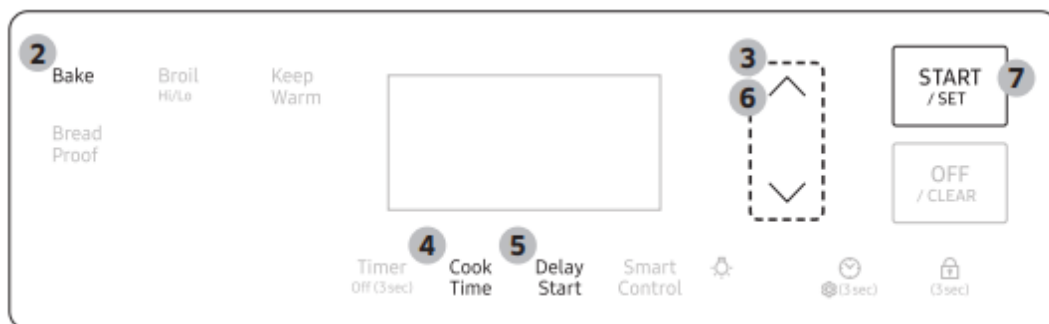

1. Place the container with the food on a rack, and then close the door.
2. Press the pad corresponding to a desired cooking mode such as Bake.
3. If necessary, change the temperature using the \wedge or \vee .
4. If necessary, press Cook Time and set the cooking time (see "Cook Time" on previous page).
5. Press Delay Start.
6. Set the starting time using the \wedge or \vee .
7. Press START/SET.
8. The oven starts cooking at the set time, and turns off automatically when it completes cooking.

NOTE To change the starting time, press Delay Start, and enter a new starting time, and then press START/SET.

Special features

Keep Warm

Keep cooked food warm at a low temperature for up to 3 hours.

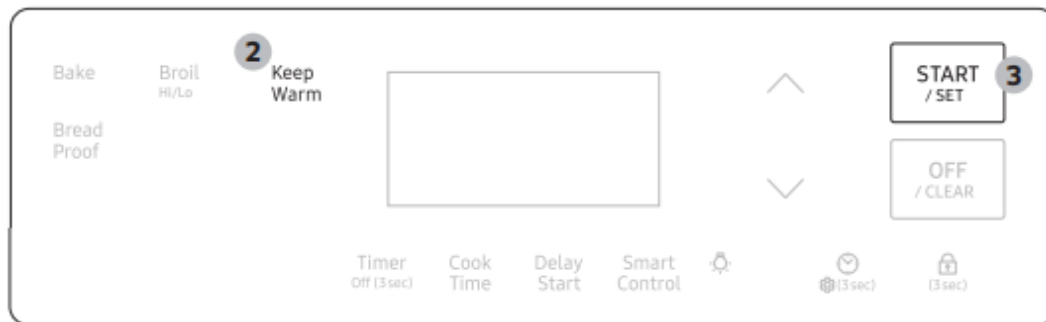

1. Place the container with the food on a rack, and then close the door.
2. Press Keep Warm.
3. Press START/SET. The oven heats up to 175 °F (80 °C).

NOTE

- You can cancel warming at any time by pressing OFF/CLEAR.
- To set the warming function during a timed cooking, press Keep Warm in timed cooking mode. When the timed cooking is complete, the oven will lower the temperature to the warming default, and keep that temperature until the warming finishes or is canceled.

Bread Proof

The Bread Proof function automatically provides the optimum temperature for the bread proof process, and therefore does not have a temperature adjustment. If you press Bread Proof when the oven temperature is above 100 °F, Hot will appear in the display. Because this function produces the best results when started while the oven is cool, we recommend that you wait until the oven has cooled down and Hot disappears from the display.



1. Press Bread Proof.

2. Press START/SET.

3. Press OFF/CLEAR at any time to turn off the Bread Proof function.

NOTE Use rack position 3 for bread proofing.

CAUTION

- Do not use Bread Proof when the oven temperature is above 125 °F. If the temperature is above 125 °F, this mode will not heat the oven to the optimal temperature. Wait until the oven cools down.
- Do not use Bread Proof for warming food. The proofing temperature is not hot enough to keep food warm.
- Place the dough in a heat-safe container on rack position 3 or 4 and cover it with a cloth or with plastic wrap. You may need to anchor the plastic wrap underneath the container so that the oven does not blow it off the dough.
- To avoid lowering the temperature and extending proofing time, do not open the oven door.

To enable the Sabbath option

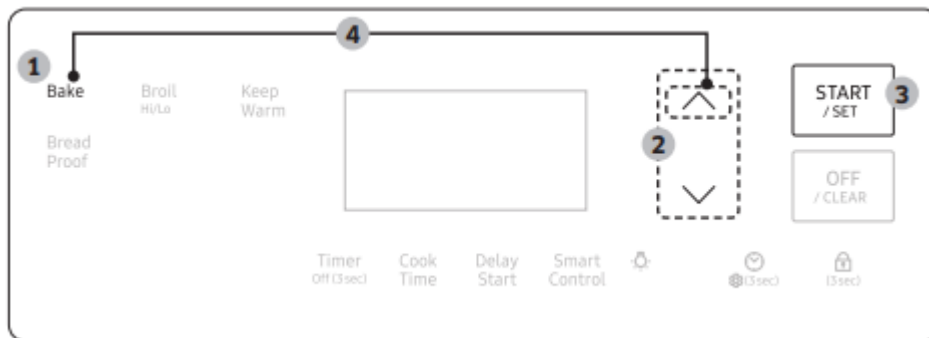

1. Press Bake.

2. Enter a desired temperature using the \wedge or \vee pad. The default temperature is 350 °F.

3. Press START/SET. The display temperature changes after the oven temperature reaches 175 °F.

4. Press Bake and \wedge simultaneously for 3 seconds to display "SAb". Once "SAb" appears, the oven control no longer beeps or displays any further changes.

NOTE

- You can change the oven temperature once baking starts, but the display will not change or beep. After changing the temperature, it takes 15 seconds before the oven recognizes the change.
- You can turn off the oven at any time by pressing OFF/CLEAR. However, this doesn't deactivate the Sabbath option.
- To deactivate the Sabbath option, hold down Bake and \wedge simultaneously for 3 seconds.

- You can set the cooking time before activating the Sabbath option.
- After a power failure, the oven will not resume operation automatically. "SAb" will appear in the control panel, but the oven will not turn back on. Food can be safely removed from the oven, but you should not turn off the Sabbath option and turn the oven back on until after the Sabbath/Holidays.
- After the Sabbath observance, turn off the Sabbath option by pressing and holding Bake and \wedge simultaneously for at least 3 seconds.

CAUTION

- Do not attempt to activate any other functions except for Bake when the Sabbath option is on. Only the following pads will function properly: \wedge or \vee pads, Bake, Oven Start/Set, and Oven Off.
- Do not open the oven door or change the oven temperature for about 30 minutes after you have started the Sabbath option. Let the oven reach the set temperature. The oven fan operates only when the oven temperature increases

Oven lock

Lock the control panel and the door to prevent accidental operations and/or product tipping.

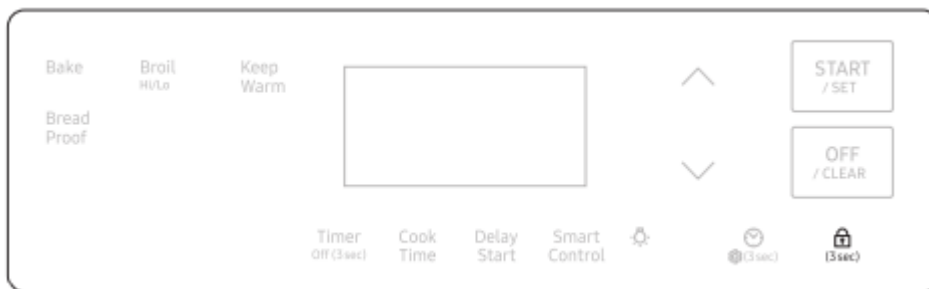



Press and hold  for 3 seconds to lock or unlock both the control panel and the door. When the Oven Lock is on, the oven panel does not operate and the oven door is locked and cannot be opened.

Changing the settings

Demo mode

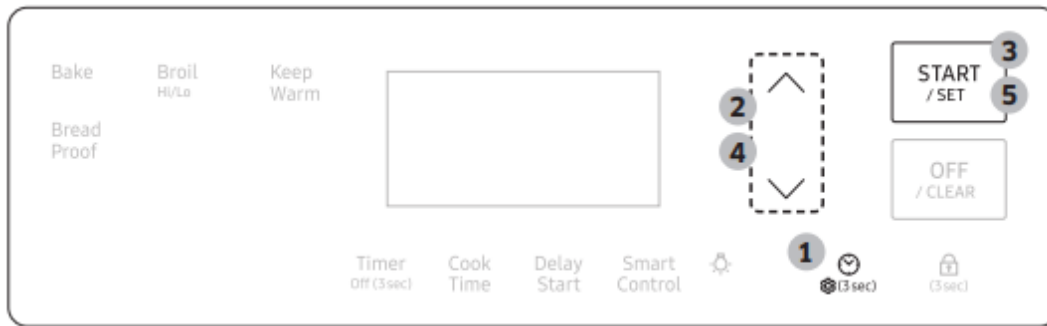
This is used by retailers for display purposes only. In this mode, the heating element does not operate.



1. Press and hold  for 3 seconds.
2. Press \wedge or \vee to set the number to 0.
3. Press START/SET to enter to Demo mode.
4. Press \wedge or \vee to select Off or On.
5. Press START/SET to save the change.

Temperature adjust

The oven temperature has been calibrated at the factory. When first using the oven, follow the recommended recipe times and temperatures. If it appears that the oven is too hot or too cool, you can recalibrate the oven temperature. Before recalibrating, test a recipe by using a temperature setting that is higher or lower than recommended. The baking results should help you decide how much of an adjustment is needed. The oven temperature can be adjusted by $\pm 35^{\circ}\text{F}$ ($\pm 19^{\circ}\text{C}$).





1. Press and hold  for 3 seconds.
2. Press \wedge or \vee to set the number to 1.
3. Press START/SET to enter to Temperature adjust.
4. Press \wedge or \vee to enter an adjusting temperature value (-35~35).
5. Press START/SET to save the changes.

NOTE This adjustment does not affect the broiling or the self-cleaning temperature, and is retained in memory after a power failure.

Temperature Unit ($^{\circ}\text{F}$ / $^{\circ}\text{C}$)

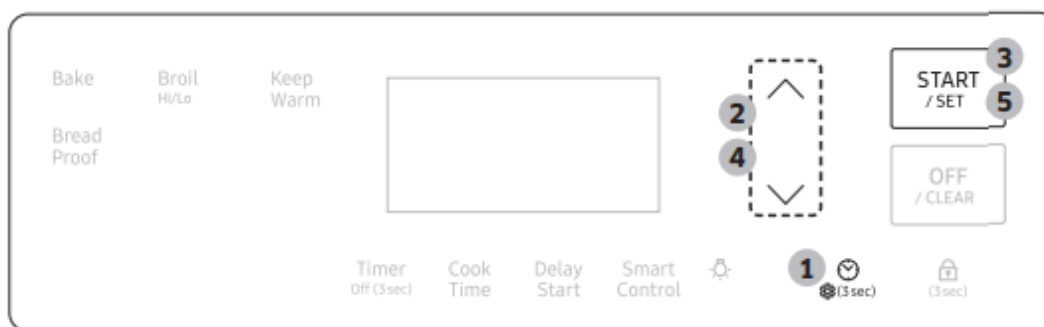
Change the temperature unit of the oven to Fahrenheit or Celsius. The default is Fahrenheit.



1. Press and hold  for 3 seconds.
2. Press \wedge or \vee to set the number to 2.
3. Press START/SET to enter to Temperature unit.
4. Press \wedge or \vee to select Fahrenheit or Celsius.
5. Press START/SET to save the change.

Energy saving

This will automatically turn off the oven 12 hours after baking starts or 3 hours after broiling starts.



1. Press and hold  for 3 seconds.
2. Press \wedge or \vee to set the number to 3.
3. Press START/SET to enter to Energy saving.
4. Press \wedge or \vee to select Off (--Hr) or On (12Hr).
5. Press START/SET to save the change.

Smart Control

How to connect the oven

1. Download and open the SmartThings app on your smart device.
2. Follow the app's on-screen instructions to connect your range.
3. Once the process is complete,  icon appears in the display and the app will confirm you are connected.
4. If the connection icon does not turn on, follow the instruction on the app to reconnect.





To control the oven remotely

1. Press Smart Control  appears in the display. The oven can now be controlled remotely with a connected device.
2. Select the oven icon on the SmartThings app to open the Oven Control app. When the app is connected to the oven, you can perform the following functions through the application:

| Oven remote control using the SmartThings app | |
|--|---|
| Oven/ Cooktop Monitoring | <ul style="list-style-type: none"> • Check the status of the oven. • Monitor the on/off status of each cooktop burner. |
| Oven Remote Control | <ul style="list-style-type: none"> • Set or adjust oven settings remotely. |
| My Cooking | <ul style="list-style-type: none"> • Turn the oven off remotely. • Once cooking starts, change the set cooking time and temperature remotely. |
| Error Check | <ul style="list-style-type: none"> • Automatically recognize errors. |
| Temp Probe | <ul style="list-style-type: none"> • Monitor the current temperature and reset the probe setting. (For some available models.) |
| <ul style="list-style-type: none"> • If  is not shown in the display, you are still able to monitor the oven and cooktop status and turn the oven off. | |

NOTE

- Opening the oven door or pressing Smart Control will delete  from the display and prevent most of the remote functions from operating.

- When oven cooking is finished or cancelled,  is removed from the display.
- For safety reasons, you cannot turn on the gas oven remotely.
- For safety reasons, you must specify the cooking time to enable remote control.
- The oven continues operating even if the Wi-Fi connection is lost.
- Smart Control will not work properly if the Wi-Fi Connection is unstable.
- See the SmartThings app manual for detailed information.



Maintenance

Cleaning

CAUTION Wear the glove during cleaning.

Control panel

First, lock the control panel and the door to prevent accidental operations and/or product tipping.

1. Press and hold  for 3 seconds to lock both the control panel and the door.
2. Clean the control panel using a soft cloth dampened with plain water, warm soapy water, or glass cleaner. Do not spray cleansers directly onto the control panel.
3. When done, press and hold  again for 3 seconds.

WARNING

- Make sure the control panel turns off and all surfaces of the range are cool before cleaning. Otherwise, you can get burned.
- If the range has been moved away from the wall, make sure the Anti-Tip device is reinstalled properly when the range has been put into place again. Otherwise, the range may tip over, causing physical injuries.
- Do not use steel-wool or abrasive cleansers of any kind. These can scratch or damage the surface.

Stainless steel surface

1. Remove any spills, spots, and grease stains using a soft, wet cloth.
2. Apply an approved stainless steel cleanser to a cloth or paper towel.
3. Clean one small area at a time, rubbing with the grain of the stainless steel if applicable.
4. When done, dry the surface using a soft, dry cloth.
5. Repeat steps 2 through 4 as many times as necessary

CAUTION

- Do not use a steel-wool pad or abrasive cleanser on stainless steel surfaces. It will scratch the surface.
- Do not spray any type of cleanser into the manifold holes. The ignition system is located in those holes and must be kept free of moisture.

Racks

To keep the racks clean, remove them from the cavity, and soak them in lukewarm soapy water. Then, scour soil off of the racks using a plastic scouring pad. If the racks do not slide in and out smoothly after you have cleaned them, rub the side rail guides with wax paper or a cloth containing a few drops of cooking oil. This will help the racks glide more easily on their tracks.

NOTE

- Do not put the racks in a dishwasher.
- If a rack does not slide in and out smoothly, apply a few drops of cooking oil to the oven rack guides.
- If a rack becomes too difficult to slide in or out, lubricate the rack with graphite lubricant.
- To purchase the graphite lubricant, contact us at 1-800-SAMSUNG (726-7864).
- For online shopping, visit Website and search for part DG81-01629A.

CAUTION

- Do not leave the racks in the oven during the self-cleaning cycle. The extreme heat generated in this cycle can permanently peel off the rack coating and make it difficult to slide the racks on the guide rails.
- Do not spray cooking oil or lubricant directly onto the racks.

Oven

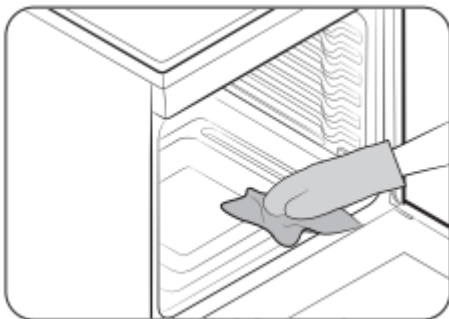

- Wear the glove during cleaning.

Door

Do not remove the inner gasket of the oven door for cleaning.

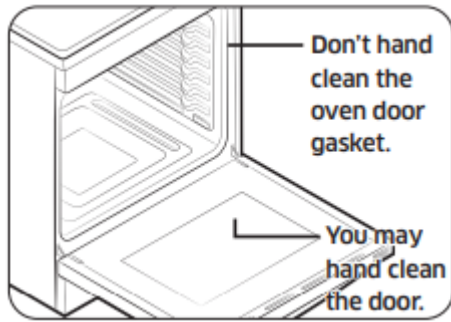

- Use soap and water to thoroughly clean the top, sides, and front of the oven door. Rinse well. You may use a glass cleaner on the outside glass of the oven door. DO NOT immerse the door in water. DO NOT spray or allow water or the glass cleaner to enter the door vents. DO NOT use oven cleaners, cleaning powders, or any harsh abrasive cleaning materials on the outside of the oven door.
- DO NOT clean the oven door gasket. The oven door gasket is made of a woven material which is essential for a good seal. Care should be taken not to rub, damage, or remove this gasket.

Door inner side

- Inner surface: Clean the inner side of the door manually using a soapy plastic scouring pad, and then wipe with a dry cloth. Take care not to get the gasket wet or allow moisture into the door.
- Inner glass: The inner glass is cleaned automatically during the self-cleaning cycle.

Door outer side

- Outer surface: Follow the cleaning instructions for the stainless steel surface in the previous section.
- Outer glass: Clean the outer glass using a glass cleanser or soapy water. Rinse and dry thoroughly. Take care not to get the gasket wet or allow moisture into the door.

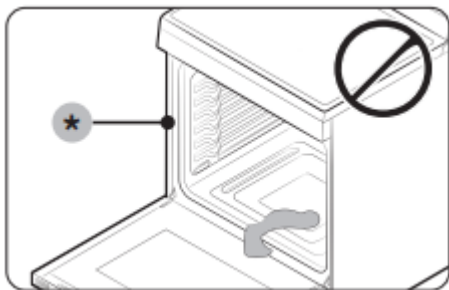

CAUTION Do not let moisture enter the door or contact the door gasket. Moisture may reduce the gasket's performance.

Burner controls

Make sure all surface burner knobs are in the OFF position.

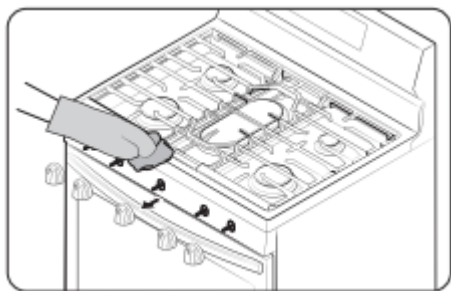

1. Pull knobs off the control valve stems.
2. Clean the knobs in warm, soapy water. Then, rinse and dry them thoroughly.
3. Clean the stainless steel surfaces using stainless steel cleaner.
4. Re-attach the knobs to the control valve stems.

CAUTION

- Do not clean the control knobs in a dish washer.
- Do not spray cleansers directly onto the control panel. Moisture entering the electric circuits may cause electric shock or product damage.

Cooktop surface

The porcelain-enameled cooktop surface needs to be kept clean. We recommend that you remove food spills immediately after they take place.

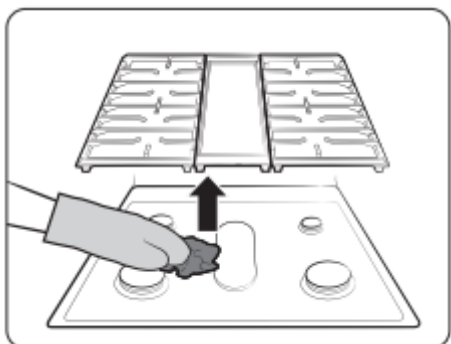

1. Turn off all surface burners.
2. Wait until all burner grates cool down, and then remove them.
3. Clean the cooktop surface using a soft cloth. If food spills run into gaps of the burner components, remove the burner cap and the head, and wipe up the spills.
4. When cleaning is finished, reinsert the burner components, and then put the burner grates back into position.

CAUTION

- Do not use a steel-wool pad or abrasive cleaner, which can scratch or damage the enamel surface.

- Do not remove the cooktop surface to clean it. The gas lines leading to the burner manifolds can be damaged, resulting in a fire or system failure.
- Do not pour water into the cooktop well while cleaning the cooktop. This could leak down into the range gas and electrical systems creating a risk of electrical shock or high levels of carbon monoxide due to corrosion of the gas valves or ports.
- Keep oven vent ducts unobstructed. Clean vents frequently to avoid grease buildup.

Replacing the oven light

Oven light

The oven light is a standard 40-watt appliance bulb. It comes on when you open the oven door.

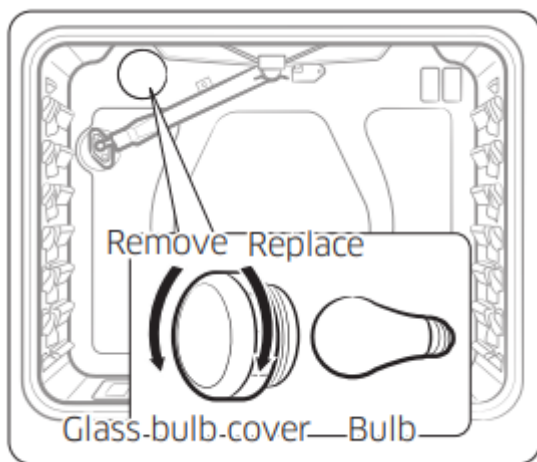

1. Turn off the oven.
2. Make sure the oven and oven light are cool.
3. Open the door, and remove the glass cover by turning it counterclockwise.
4. Remove the oven light from the socket by turning it counterclockwise.
5. Insert a new 40-watt appliance bulb into the socket, and then turn it clockwise to tighten.
6. Reinsert the glass cover, and then turn it clockwise to tighten.

CAUTION To prevent electric shock, make sure the oven is turned off and cool before replacing the oven light.

NOTE

- The oven light does not operate during the self-cleaning cycle.
- Remove the racks if they prevent you from accessing the oven light

Troubleshooting

If you encounter a problem with the range, check the tables starting below, and then try the suggested actions.

Checkpoints

Gas safety

| Problem | Possible cause | Action |
|----------------|---|---|
| You smell gas. | The surface burner knob is not in the OFF position and the burner is not lit. | Turn the burner knob to OFF. |
| | There is a gas leak. | Clear the room, building, or area of all occupants. Immediately call your gas supplier from a neighbor's phone. Do not call from your phone. It is electrical and could cause a spark that could ignite the gas. Follow the gas supplier's instructions. If you cannot reach your gas supplier, call the fire department. |



Surface burner



| Problem | Possible cause | Action |
|---|---|--|
| All burners do not light. | The power cord is not plugged into the electrical outlet. | Make sure the electrical plug is plugged into a live, properly grounded outlet. |
| | A fuse in your home may be blown or the circuit breaker may have tripped. | Replace the fuse or reset the circuit breaker. |
| | The gas supply is not properly connected or turned on. | See the Installation Instructions that came with your range. |
| Surface burners do not light. | The control knob is not set properly. | Push in the control knob and turn it to the Lite position. |
| | The burner caps are not in place. The burner base is misaligned. | Clean the electrodes. Put the burner cap on the burner head. Align the burner base. |
| Surface burner clicks during operation. | The control knob has been left in the Lite position. | After the burner lights, turn the control knob to a desired setting. If the burner still clicks, contact a service technician. |
| The burners do not burn evenly. | Surface burner components and caps are not assembled correctly and level. | See page 35. |
| | The surface burners are dirty | Clean the surface burner components. (See page 34.) |
| Very large or yellow surface burner flames. | The wrong burner orifice is installed. | Check the burner orifice size. Contact your installer if you have the wrong orifice (LP gas instead of natural gas or natural gas instead of LP gas). |

| | | |
|--|--|---|
| Surface burners light but oven burners do not light. | The oven door lock is turned on. | The display will show the Lock icon. Hold the oven door open and press  for 3 seconds. The oven will beep and the Lock icon will turn off. |
| | The Gas Pressure Regulator shut off switch is in the off position. | Call a qualified service technician. |

Oven



| Problem | Possible cause | Action |
|--|---|---|
| The oven control beeps and displays an information code. | There may be an issue with your oven. See the "Information codes" chart on page 44. | Press OFF/CLEAR, and then restart the oven. If the problem persists, disconnect all power to the range for at least 30 seconds and then reconnect the power. If this does not solve the problem, call for service. |
| The oven will not turn on. | The oven is not completely plugged into the electrical outlet. | Make sure the electrical plug is fully inserted into a live, properly grounded outlet. |
| | A fuse in your home may be blown or the circuit breaker may have tripped. | Replace the fuse or reset the circuit breaker. |
| The oven temperature is too hot or cold. | The oven temperature needs to be adjusted and recalibrated. | See page 28. |
| The oven burner will not shut off. | The oven door lock is turned on. | The display will show the Lock icon. Hold the oven door open and press  for 3 seconds. The oven will beep and the Lock icon will turn off. |
| | The Sabbath function has been activated. | SAB and the time of day will show in the display. All other controls and signals will be deactivated. To turn off the oven only, press OFF/CLEAR. To cancel the Sabbath function and reactivate the controls and signals, press and  hold Bake and simultaneously for 3 seconds. |
| Oven fan is making a noise, or won't turn off. | The cooling fan is not visible, but you will hear it running whenever the electronics get hot and | This is normal operation to cool the oven, cooling fan automatically shuts down when the oven cools. |

| | | |
|--|---|--|
| * Slide-In oven model only. | turn off when the electronics are cool. | |
| The oven light (lamp) will not turn on. | The oven door lock is turned on. | The display will show the Lock icon. Hold the oven door open, and then press  for 3 seconds. The oven will beep and the Lock icon will turn off. |
| | The Sabbath function has been activated. | SAB and the time of day will show in the display. All other controls and signals will be deactivated. To cancel the Sabbath function and reactivate the light switch and other controls, press and hold Bake and  simultaneously for 3 seconds. |
| | A loose or burned-out bulb. | See page 37. |
| | The switch operating the oven light needs to be replaced. | Call for a qualified service technician. |
| The oven smokes excessively during broiling. | Meat or food was not properly prepared before broiling. | Cut away excess fat and/or fatty edges that may curl. |
| | Improperly positioned top oven rack. | See the broiling guide on page 23. |
| | The controls are not being set properly. | See page 23. |
| | Greasy buildup on oven surfaces. | Regular cleaning is necessary when broiling frequently. |

| | | |
|--|--|--|
| Cooking is finished, but the cooling fan is still running. | The fan automatically runs for a certain amount of time to ventilate the inside of the oven. | This is not a product malfunction. The fan is designed to run automatically for a period of time to cool down the oven. |
| The oven will not self-clean. | The oven door lock is turned on. | The display will show the Lock icon. Hold the oven door open, and then press Q for 3 seconds. The oven will beep and the Lock icon will turn off. |
| | The oven is too hot. | Let the oven cool down, and then reset the controls. The self-clean cycle will not lock the oven door if the oven temperature is too hot. The door must lock before the selfclean cycle can start. |
| | The self-cleaning oven controls are not properly set. | Reset the self-cleaning oven controls. (See page 35 .) |
| | A surface burner is on. | Turn off the surface burner. Self-clean will not operate if a surface burner is on. |
| A crackling or popping sound. | This is normal. | This is the sound of the metal heating and cooling during any cooking or cleaning function. |

| | | |
|---|--|---|
| <p>Excessive smoking during a selfcleaning cycle.</p> | <p>This is the first time the oven has been cleaned.</p> | <p>This is normal. The oven will always smoke more the first time it is cleaned.</p> <p>Wipe up all excessive soil before starting the selfcleaning cycle.</p> <p>If smoke persists, press OFF/CLEAR. Open the windows to clear the smoke from the room. After the oven has cooled and unlocked, wipe up excessive soil, and then reset the oven for selfcleaning.</p> |
| <p>The oven door will not open after a self-cleaning cycle.</p> | <p>This is normal.</p> | <p>The oven door will stay locked until the oven temperature drops below 400 °F.</p> |
| <p>The oven is not clean after a selfcleaning cycle.</p> | <p>A fine dust or ash is normal.</p> | <p>This can be wiped clean with a damp cloth.</p> <p>Set the self-cleaning cycle for a longer cleaning time.</p> <p>The cycle was not long enough to burn off the dirt buildup. Extremely dirty ovens require hand-cleaning of excessive spillovers and food buildup before you start a self-cleaning cycle. Multiple self-cleaning cycles may be necessary to completely clean the oven.</p> |



| | | |
|--|--|---|
| There is steam or smoke coming from under the control panel. | This is normal. | The oven vent is located there. More steam is visible when you are using the convection functions or when baking or roasting multiple items at the same time. |
| A burning or oily odor coming from the vent. | This is normal for a new oven and will disappear within 72 hour of the first bake cycle. | To speed the process, set a self-cleaning cycle for a minimum of 3 hours. (See page 35 .) |
| Strong odor. | This is temporary. | The insulation around the inside of the oven emits an odor the first few times the oven is used. |
| The oven racks are difficult to slide. | This is normal. | Apply a small amount of vegetable oil to a paper towel, and then wipe the edges of the oven racks with the paper towel. Racks become dull and hard to slide if they are left in the oven during a self-clean cycle. |
| Fan noise. | This is normal. | The convection fan runs until the function is over or the door is opened. |

Others

| Problem | Cause | Action |
|---------------------------|---|---|
| The product is not level. | <p>The appliance has been installed improperly.</p> <p>The leveling leg(s) is (are) damaged or uneven.</p> | <p>Make sure the floor is level, strong, and stable. If the floor sags or slopes, contact a carpenter.</p> <p>Check and level the range. (See the Installation Instructions.)</p> |
| | The kitchen cabinets are not properly aligned and make the range appear to be not level. | Ensure that cabinets are square and provide sufficient room for installation. |
| The display goes blank. | <p>The electrical outlet Ground Fault Interrupter (GFI or GFCI) has been tripped and needs to be reset.</p> <p>Your digital control has been damaged.</p> | Replace the fuse or reset the circuit breaker. |

| | | |
|---|--|--|
| Food does not bake or roast properly in the oven. | The wrong cooking mode was selected. | See page 22 . |
| | The oven racks have not been positioned properly for the foods being cooked. | See page 20 . |
| | Incorrect cookware or cookware of improper size is being used. | See page 18 . |
| | The oven temperature needs to be adjusted and recalibrated. | See page 28 . |
| | There is aluminum foil on racks and/or oven bottom. | Remove foil. |
| | The clock or timers are not set correctly. | See page 24 . |
| Food does not broil properly in the oven. | The oven controls are not set properly. | See page 23 . |
| | The oven door was not closed during broiling. | See page 22 . |
| | The rack has not been properly positioned. | See the broiling guide on page 23 . |

Information codes

| Code symbol | Meaning | Solution |
|--|--------------------------------------|--|
| C-20 | Oven sensor malfunction. | <p>1. Press OFF/CLEAR, and then restart the oven.</p> <p>2. If the problem persists, disconnect all power to the oven range for at least 30 seconds and then reconnect the power.</p> |
| C-21 | The oven is overheating. | |
| C-22 | Check the Control PBA NTC sensor. | |
| C-30 | Check the PBA NTC Sensor. | |
| C-31 | Check the PBA NTC Sensor. | |
| C-d0 | Control pad malfunction. | |
| C-d1 | Door lock malfunction. | |
| C-F0 | PCB signal malfunction. | |
| C-F2 | Touch 1C and PCB signal malfunction. | |
| C-24 | Oven vent blocked. | |
| <p>** If these solutions do not solve the problem, contact a local Samsung service center or call 1-800-SAMSUNG (1-800-726-7864).</p> | | |

Warning

This content is compiled from multiple sources and is provided for reference purposes only. It may not be complete or fully applicable to all situations. If you are unable to resolve your issue, please contact the product manufacturer or an authorized service provider for official support.

Document generated by [ManualsFile](#)