

Operating the water heater.

CAUTION: Hydrogen gas can be produced in a hot water system served by this water heater that has not been used for a long period of time (generally two weeks or more). HYDROGEN GAS IS EXTREMELY FLAMMABLE!! To dissipate such gas and to reduce risk of injury, it is recommended that the hot water faucet be opened for several minutes at the kitchen sink before using any electrical appliance connected to the hot water system. If hydrogen is present, there will be an unusual sound such as air escaping through the pipe as the water begins to flow. Do not smoke or use an open flame near the faucet at the time it is open.

Safety Precautions

- A. Do not turn off manual gas shut-off valve if water heater has been subjected to over heating, fire, flood, physical damage or if the gas supply fails to shut off.
- B. Do Not turn on water heater unless it is completely filled with water.
- C. Do Not turn on water heater if cold water supply shut-off valve is closed.
- D. Do Not allow combustible materials such as newspaper, rags or mops to accumulate near water heater.
- E. Do Not store or use gasoline or other flammable vapors and liquids, such as adhesives or paint thinner, in vicinity of this or any other appliance. If such flammables must be used, open doors and windows for ventilation, and all gas burning appliances in the vicinity should be shut off including their pilot burners, to avoid vapors lighting.
NOTICE: Flammable vapors can be drawn by air currents from surrounding areas to the water heater.
- F. If there is any difficulty in understanding or following the Operating Instructions or the Care and Cleaning section, it is recommended that a qualified person or serviceman perform the work.

Operating Procedure

- This heater is equipped with an electronically lit pilot to light the main burner. The pilot is automatically lit each time there is a demand for heating the water. On initial start-up, it is recommended that the outer door be removed (leave inner door in place for safety) to determine if the pilot and main burner are operating properly. Once filled with water, it is necessary to plug the power cord in and make sure the "ON/OFF" switch located on the blower assembly is in the "ON" position and the gas control switch is in the "ON" position. The blower will start and within seconds the pilot will light followed by the main burner. After the main burner ignites, replace the outer door.

- If no main burner flame is established, the gas control will go through three trials for ignition before going into a lock-out. A warning light will alert the user of this lock-out condition. If this happens, refer to “Troubleshooting Guide.”

Water Temperature Setting

DANGER: Hotter water increases the Potential for Hot Water SCALDS. Households with small children, disabled, or elderly persons may require a 120°F or lower gas control (thermostat) setting to prevent contact with HOT water.

- The temperature of the water in the water heater can be regulated by turning the knob on the front of the gas control (thermostat). Safety and energy conservation are factors to be considered when selecting the water temperature setting of the water heater’s gas control (thermostat(s)). The lower the temperature setting, the greater the savings in energy and operating costs.
- To comply with safety regulations, the gas control (thermostat) was set at 120°F before the water heater was shipped from the factory. The recommended starting point temperature is 120°F.
- Water temperatures above 125°F can cause severe burns or death from scalding. Be sure to read and follow the warnings outlined in this manual and on the label located on the water heater near the gas control thermostat.
- Mixing valves are available for reducing point of use water temperature by mixing hot and cold water in branch water lines. Contact a licensed plumber or the local plumbing authority for further information. (See page 4 for more details.)
- The chart on the next page may be used as a guide in determining the proper water temperature for your home.
- The following is additional information which aid in determining a safe working temperature to meet each household need.
- Maximum water temperatures occur just after the burner has shut off. To determine the water temperature, turn on a hot water faucet and place a thermometer in the water stream. If an adjustment to the water temperature is preferred, then refer to the Water Heater User Display – Operation Instructions for instruction on adjusting the local and remote user display temperature setpoints.
- A condition known as “stacking” or “layering” can occur when a series of short and frequent hot water draws are taken. The hottest temperature water will be at the top of the tank, closest to the outlet pipe delivering hot water to the home.
- Stacking can cause this top layer of water to be hotter than the water toward the bottom of the tank near the gas control (thermostat). Therefore, always remember to test the water temperature with your hand before use and remember that hotter water increases

the risk of scald injury. Also, always supervise young children or others who are incapacitated.

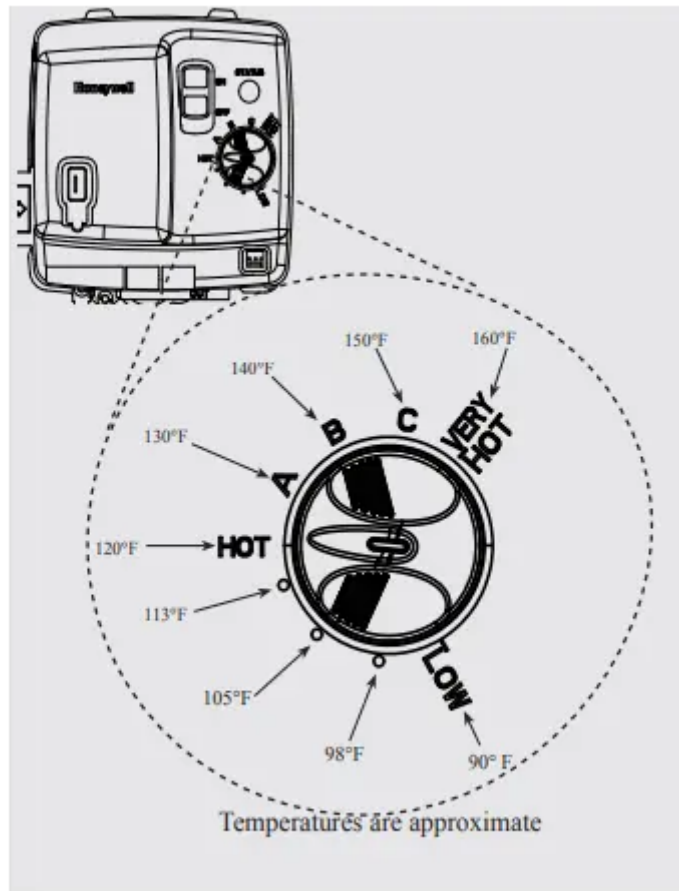

- The gas control (thermostat) is constructed with a built in safety shut-off device designed to shut off the gas supply to the burner if the main burner is extinguished for any reason. The gas control (thermostat) is also equipped with a gas shut off device that will shut off the gas supply to the burner if the water heater exceeds normal operating temperatures. Refer to the “Before You Call For Service” section of this manual, or contact your dealer.
- **WARNING:** Should overheating occur or the gas supply fail to shut off, turn off the manual gas control valve to the appliance
- If the water heater has been subjected to fire, flood or physical damage, turn off the manual gas control (shut-off) valve and do not operate the water heater again until it has been checked by a qualified service technician.
- **NOTICE:** Replace any part of the gas control system which has been under water.

Time/Temperature Relationship in Scalds

Water Temperature	Time To Produce a Serious Burn
120°F	More than 5 minutes
125°F	1½ to 2 minutes
130°F	About 30 seconds
135°F	About 10 seconds
140°F	Less than 5 seconds
145°F	Less than 3 seconds
150°F	About 1½ seconds
155°F	About 1 second

Table courtesy of Shriners Burn Institute

Sequence of Operation...

1. During initial start-up or a call for heat, the control will verify the vacuum switch is open.
2. Once the control verifies the blower vacuum switch is open, the control will energize the blower motor for the pre-purge sequence (approximately 5 seconds).
3. The control will verify the blower vacuum switch has closed, ensuring that the blower is functioning properly and that the venting system is not blocked.
4. The control will then proceed through a sequence of self-diagnostics before initiating a trial for ignition.
5. During the trial for ignition, the pilot will spark in an attempt to light the pilot. Once the pilot flame is established, the main gas valve will open allowing gas to flow to the main burner.
6. The main burner and pilot will remain lit throughout the heat cycle until the water temperature setting is reached.
7. Once the water temperature setting is reached, the control will close the main gas valve and pilot valve which will extinguish both the main burner and pilot burner flames.
8. The blower motor will stay energized for an additional 30 seconds after the control verifies that the burner flame is extinguished in order to clear combustion gases from the water heater.
9. After the post-purge sequence, the control will de-energize the blower motor and go into a stand-by mode awaiting the next call for heat.

This water heater is equipped with a flammable vapor sensor that is monitored continuously by the electronic control in all modes of operation.

In the event that flammable vapors are detected, the control will automatically shut down the water heater and prevent the water heater from being started again.

The following is a list of materials that will cause the Flammable Vapor Sensor to shut down the water heater.

- Vapors of Gasoline.
- Vapors of certain flammable paints, stains, and thinners.
- Vapors of vent pipe Cement & Solvents.
- Bleach (direct contact with flammable vapor sensor).
- Some other flammable materials and their vapors.

If the flammable vapor sensor shuts down the water heater, then the electronic control will display the appropriate error code and you should then promptly contact a qualified service technician.

Refer to the “WARNING” on page 3 for additional information.

Care and cleaning of the water heater.

Draining the Water Heater

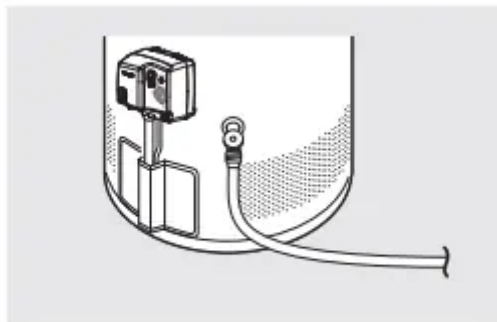

- CAUTION: Shut off gas to the water heater at the gas control (thermostat) gas cock or manual shut-off valve before draining water.
- DANGER: Before manually operating the temperature and pressure relief valve, make certain no one will be exposed to the hot water released by the valve. The water drained from the tank may be hot enough to present a scald hazard and should be directed to a suitable drain to prevent injury or damage.
- Before turning off the cold water supply to the water heater, open a hot water faucet allowing sufficient cold water into the tank to prevent the risk of a scald injury while draining the water heater. Once the water in the tank is no longer hot, turn off the cold water supply to the water heater. Open a hot water faucet or lift the handle on the relief valve to admit air to the tank.
- Attach a garden hose to the drain valve on the water heater and direct the stream of water to a drain. Open the valve.

Routine Preventative Maintenance

- DANGER: Before manually operating the relief valve, make certain no one will be exposed to the danger of the hot water released by the valve. The water may be hot enough to create a scald hazard. The water should be released into a suitable drain to prevent injury or property damage.
- DANGER: Hotter water increases the potential for Hot Water Scalds.

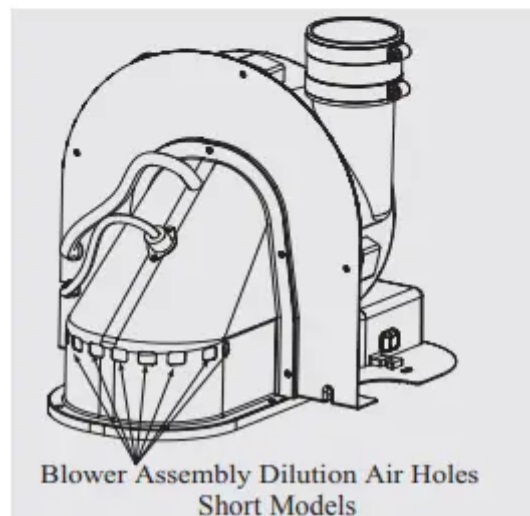
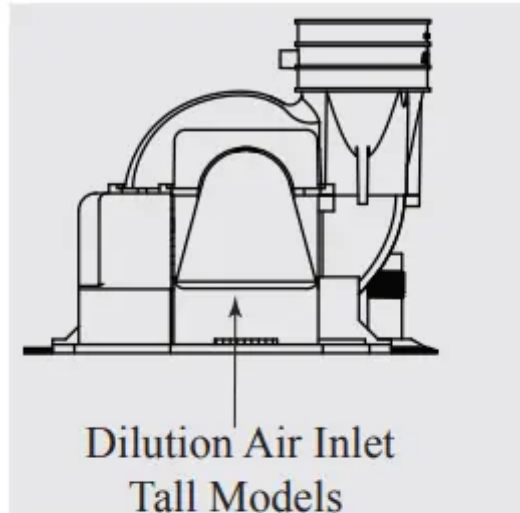

- It is recommended that a periodic inspection of the gas control (thermostat), burner, relief valve, internal flue-way and venting system should be made by service personnel qualified in gas appliance repair.
- It is suggested that a routine preventative maintenance program be established and followed by the user.
- Inspect plastic vent pipe. Make certain that all joints are secure and that vent pipe supports are all in place. Check the outdoor vent terminal to see that it is free of obstructions, and that there is no damage nearby caused by condensate.

- Inspect dilution air inlet and combustion air inlet openings. Make certain no blockage exists. Clean any lint, dirt or oil accumulation that may exist.
- At least once a year, lift and release the lever handle on the temperature pressure relief valve, located near the top of the water heater, to make certain the valve operates freely. Allow several gallons to flush through the discharge line to an open drain.
- NOTICE: If the temperature and pressure relief valve on the water heater discharges periodically, this may be due to thermal expansion in a closed water system. Contact the water supplier or your plumbing contractor on how to correct this.
- DO NOT plug the relief valve outlet.
- A water heater's tank can act as a settling basin for solids suspended in the water. It is therefore not uncommon for hard water deposits to accumulate in the bottom of the tank. If allowed to accumulate, these solids can cover the gas control (thermostat) sensors, causing the sensors to operate erratically. Because accumulated solids can prevent the gas control (thermostat) sensors from accurately reading the water temperature, the water at the fixture can be hotter than the gas control (thermostat) setting. It is suggested that a few quarts of water be drained from the water heater's tank every month to clean the tank of these deposits.
- Rapid closing of faucets or solenoid valves in automatic water using appliances can cause a banging noise heard in a water pipe. Strategically located risers in the water pipe system or water hammer arresting devices can be used to minimize the problem.
- The anode rod should be removed from the water heater's tank annually for inspection and replaced when more than 6" of core wire is exposed at either end of the rod.
- Make sure the cold water supply is turned off before removing anode rod.
- This water heater incorporates a combustion shut off device that shuts the operation of the water heater down if undesirable combustion conditions occur, such as the presence of flammable vapors or blockage of the combustion air inlet openings. Please contact a Qualified Service Technician if this occurs.
- DANGER: Failure to perform the recommended Routine Preventative Maintenance can harm the proper operation of this water heater, which can cause carbon monoxide dangers, excessive hot water temperatures and other potentially hazardous conditions.

Housekeeping

- DANGER: Combustible materials, such as clothing, cleaning materials, or flammable liquids, etc., must not be placed against or next to the water heater.
- Visually inspect the pilot.
- To ensure sufficient ventilation and combustion air supply, proper clearances must be maintained.

- When installed in a closet, DO NOT block or obstruct any of the combustion air inlet openings located around the perimeter of the water heater. A minimum of 1" is required between these combustion air inlet openings and any obstruction.
- DO NOT obstruct or block the Flammable Vapor Sensor. The sensor does not require any maintenance or cleaning. DO NOT expose to cleaning agents.

Venting System Inspection

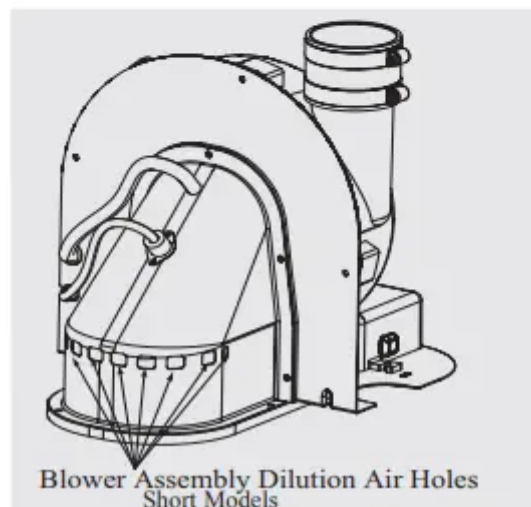
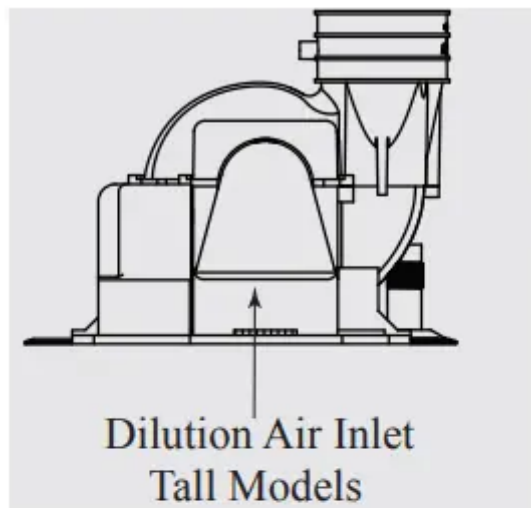

- The water heater's internal flue must be inspected annually to be certain it is clean by removing the blower assembly and flue baffle.
- When reinstalling the flue baffle make certain it is hung securely by its hanger at the top of the flue way.
- Reinstall the blower assembly.
- Inspect plastic vent pipe. Make certain that all joints are secure and that vent pipe supports are all in place. Check the outdoor vent terminal to see that it is free of obstructions, and that there is no damage nearby caused by condensate.

- Inspect dilution air holes. Make certain no blockage exists. Clean any lint, dirt or oil accumulation that may exist.
- Test for spillage at the dilution air holes after 5 minutes of burner operation. Place a blown out match or candle close to the dilution air holes. The smoke from the candle or match should be drawn into the dilution air holes. If the smoke is pushed away from the dilution air holes, the blower or vent system may be blocked. Contact qualified service personnel.

Burner Inspection

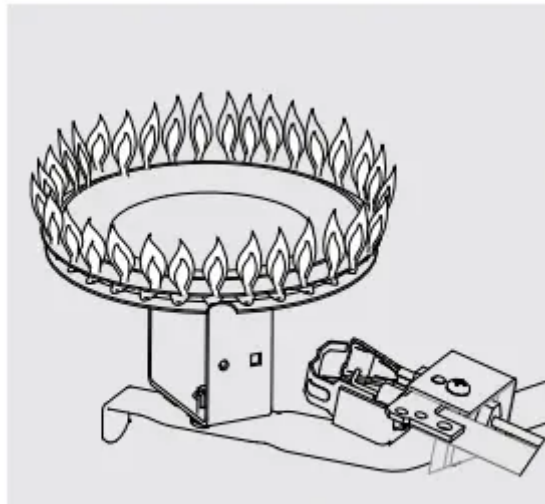

Proper burner flame pattern

- Visually inspect the pilot flame and main burner annually.
- Through the sight glass, inspect the pilot and burner lighting. If any unusual pilot or burner operation is noted, the water heater should be shut off until qualified service assistance can be obtained.
- CAUTION: For your safety, cleaning of the burner must be performed only by qualified service personnel, as it involves the disconnection of gas piping and leak testing. The burner chamber is a sealed area. If the burner access door is removed, the burner access door gasket must be replaced.
- For cleaning, remove the burner from the water heater. A vacuum cleaner can be used on the burner and floor shield inside the water heater. The burner can also be cleaned by scrubbing with mild detergent

Vacation and Extended Shut-Down

- NOTICE: Refer to the Hydrogen Gas Caution in the Operating Instructions.
- If the water heater is to remain idle for an extended period of time, the power and water to the appliance should be turned off to conserve energy and prevent a build-up of dangerous hydrogen gas.

- The water heater and piping should be drained if they might be subjected to freezing temperatures.
- After a long shut-down period, the water heater's operation and controls should be checked by qualified service personnel. Make certain the water heater is completely filled again before placing it in operation.

Anode Rod

- **NOTICE:** Do not remove the anode rod from the water heater's tank, except for inspection and/or replacement, as operation with the anode rod removed will greatly shorten the life of the glass lined tank and will exclude warranty coverage
- This water heater is equipped with an anode rod designed to prolong the life of the glass lined tank. The anode rod is slowly consumed, thereby eliminating or minimizing corrosion of the glass lined tank.
- Water sometimes contains a high sulfate and/or mineral content and together with cathodic protection process can produce a hydrogen sulfide, or rotten egg odor in the heated water. Chlorination of the water supply should minimize the problem.

Troubleshooting Tips

Save time and money! Review the charts on the following pages first and you may not need to call for service.

This water heater incorporates a combustion shut off device that shuts the operation of the water heater down if undesirable combustion conditions occur, such as the presence of flammable vapors or blockage of the combustion air inlet openings. Please contact a Qualified Service Technician if this occurs.

Problem	Possible Causes	What To Do
Condensation	This usually happens when a new water heater is filled for the first time.	This is normal. After the water in the tank warms up, the condensation will disappear. If, however, the condition persists, examine the piping and fittings for possible leaks.
	Moisture from the products of combustion condensing on the tank surface.	This is normal and will disappear in time. Excessive condensation can cause main burner outage.
	An undersized water heater will cause condensation	Use a water heater size that meets the requirements of your needs.
Yellow flame or soot	Scale on top of the burner.	Contact a qualified service technician to remove scale
	Flue or Combustion air inlet openings are restricted.	Remove obstruction or debris from flue or combustion air inlet openings on water heater jacket
	Not enough combustion or ventilation air supplied to the water heater location.	Proper operation of the water heater requires air for combustion and ventilation. See the Combustion and Ventilation Air information in the "Installing The Water Heater" section of this manual.
Unable to light the main burner	Air in gas line.	Contact a qualified service technician to purge the air from the gas line.
	Blocked Exhaust	Contact a qualified service technician to evaluate vent pipe for blockage.
	Pressure Switch	Make sure the pressure switch hose is not "kinked".
	Wire Connection not fully secured	Contact a qualified service technician to confirm wire connections
	Combustion Shut-off Device tripped,	Combustion shut-off device should be inspected by a qualified service technician.
	Gas Control Problem	Contact a qualified service technician



Main burner does not stay lit	Combustion Shutoff Device Tripped	The combustion shutoff device should be inspected by a qualified service technician.
----------------------------------	--------------------------------------	---

CAUTION: For your safety DO NOT attempt repair of gas piping, gas control (thermostat), burners, vent connectors or other safety devices. Refer repairs to qualified service personnel.



Problem	Possible Causes	What To Do
Rumbling noise	Scale and sediment	Drain the water heater to remove scale and sediment from the tank. Refer to the top of page 31.
Relief valve producing popping noise or draining	Pressure build up caused by thermal expansion to a closed system.	This is an unacceptable condition and must be corrected. Contact the water supplier or plumbing contractor on how to correct this. Do not plug the relief valve outlet.
Not enough or no hot water	Water usage may have exceeded the capacity of the water heater.	Wait for the water heater to recover after an abnormal demand.
	Low gas pressure	Check gas supply pressure and manifold pressure
	The gas control (thermostat) may be set too low.	See the "Water Temperature Setting" of The Water Heater section of this manual.
	Leaking or open hot water faucets.	Make sure all faucets are closed..
	Check valve error codes.	Refer to gas valve error code table on page 37.
	"ON/OFF" switch turned off.	Turn "ON".
	Blower unplugged.	Plug in. Verify power supply (120VAC).
	Combustion Shutoff System tripped	Contact a qualified service technician.
Water is too hot	The gas control (thermostat) is set too high.	See the "Water Temperature Setting" of The Water Heater section of this manual.
	Gas Control (Thermostat) Defective	Contact a qualified service technician to replace the gas control (thermostat).

CAUTION: Make certain power to water heater is "OFF" before removing protective cover FOR ANY REASON.



CAUTION: Label all wires prior to disconnection when servicing controls. Wiring errors can cause improper and dangerous operation. VERIFY PROPER OPERATION AFTER SERVICING.

CAUTION: For your safety DO NOT attempt repair of gas piping, gas control (thermostat), burners, vent connectors or other safety devices. Refer repairs to qualified service personnel.



Gas Valve LED Codes



LCD CODE For Optional Display	GAS VALVE LED	STATUS/ PROBLEM	PROBABLE CAUSE	SOLUTION
None	Short flash once every four seconds	IDLE (no call for heat, no fault conditions)	Temperature setpoint achieved and burner is off	No solution required
None	“Heartbeat”, alternates bright/dim	Call For Heat (no fault conditions)	Water temperature is below setpoint and burner is on	No solution required
12	One Flash, three second pause	Low flame signal (control continues to operate)	Pilot tube restriction, carbon buildup on electrode, pilot wire damage or gas supply	<ol style="list-style-type: none"> 1. Gas supply pressure is low 2. Low voltage supply 3. Pilot replacement
44	Two Flash, three second pause.	Pressure switch failed closed	Pressure switch tube blockage or faulty pressure switch.	<ol style="list-style-type: none"> 1. Pressure switch wiring incorrect 2. Replace pressure switch
46	Three Flash, three second pause	Pressure switch failed open.	Vent blockage or improper insallation, switch tube blockage, faulty switch, blower improper operation or temperature switch open	<ol style="list-style-type: none"> 1. Pressure switch wiring incorrect 2. Replace pressure switch 3. Air intake or exhaust obstructed 4. Replace blower

				<p>temperature switch</p> <p>5. Replace blower</p>
31	Four Flash, three second pause	TCO limit lockout	Thermal well fault, gas control fault or tank is not filled with water	<ol style="list-style-type: none"> 1. Reset valve and check for proper valve cycling 2. Make sure tank is full of water
14	Five Flash, three second pause	Flame out of sequence	Pilot or burner valve has failed open	<ol style="list-style-type: none"> 1. Replace gas valve control
11	Six-One Flash, three second pause	Failed trial for ignition	Insufficient gas supply, unstable pilot, carbon buildup on electrode or wire/pilot tube damage	<ol style="list-style-type: none"> 1. Check gas supply 2. Replace pilot
45	Six-Two Flash, three second pause	Recycle limit - PS/limit opened	Vent blockage or improper installation, switch tube blockage, faulty switch, blower improper operation, blower temperature switch open or excessive wind at vent termination	<ol style="list-style-type: none"> 1. Pressure switch wiring incorrect 2. Replace pressure switch 3. Air intake or exhaust obstructed 4. Replace blower temperature switch 5. Replace blower 6. Check for vent termination

				compliance as stated in this manual
13	Six-Three Flash, three second pause	Recycle limit - flame lost	Pilot tube restriction, low gas supply pressure, carbon buildup on electrode, wire/pilot tube damage or combustion air port blockage	<ol style="list-style-type: none"> 1. Gas supply pressure is low 2. Jacket air holes obstructed 3. Pilot replacement
14	Six-Four Flash, three second pause	Soft Lockout - flame out of sequence sensed	Valve stuck in open position	<ol style="list-style-type: none"> 1. Replace gas valve control
47	Seven Flash, three second pause	Flammable vapor sensor lockout	Gasoline or other flammable gas was detected near the appliance or the sensor has failed	<ol style="list-style-type: none"> 1. Verify no gasoline or flammable vapors are present 2. Reset control using ON/OFF switch on the gas control valve 3. Replace the flammable vapor sensor
49	Eight-One Flash, three second pause	FVS fault detected	Flammable vapor sensor resistance is out of range, wiring to FV sensor is faulty or control is faulty	<ol style="list-style-type: none"> 1. Replace FV sensor 2. Replace FV sensor wiring. 3. Replace gas control valve
89	Eight-Two Flash, three		Thermal well fault	



	second pause	Temperature sensor fault detected		<ol style="list-style-type: none"> 1. Check thermal well wiring connection 2. Relace thermal well
15	Eight-Three Flash, three second pause	Electronics fault detected	Thermal well fault or gas control fault	<ol style="list-style-type: none"> 1. Replace gas control valve 2. Replace thermal well
93	Eight-Four Flash, three second pause	Valve fault detected	Gas control valve needs to be reset or has been damaged	<ol style="list-style-type: none"> 1. Cycle power to gas control valve 2. Replace gas control valve

CAUTION: Make certain power to water heater is “OFF” before removing protective cover FOR ANY REASON.

CAUTION: Label all wires prior to disconnection when servicing controls. Wiring errors can cause improper and dangerous operation. VERIFY PROPER OPERATION AFTER SERVICING.

CAUTION: For your safety DO NOT attempt repair of gas piping, remote control, burners, vent connectors or other safety devices. Refer repairs to qualified service personnel.

Warning

This content is compiled from multiple sources and is provided for reference purposes only. It may not be complete or fully applicable to all situations. If you are unable to resolve your issue, please contact the product manufacturer or an authorized service provider for official support.

