

## USER MANUAL Rechargeable Vacuum Cleaner

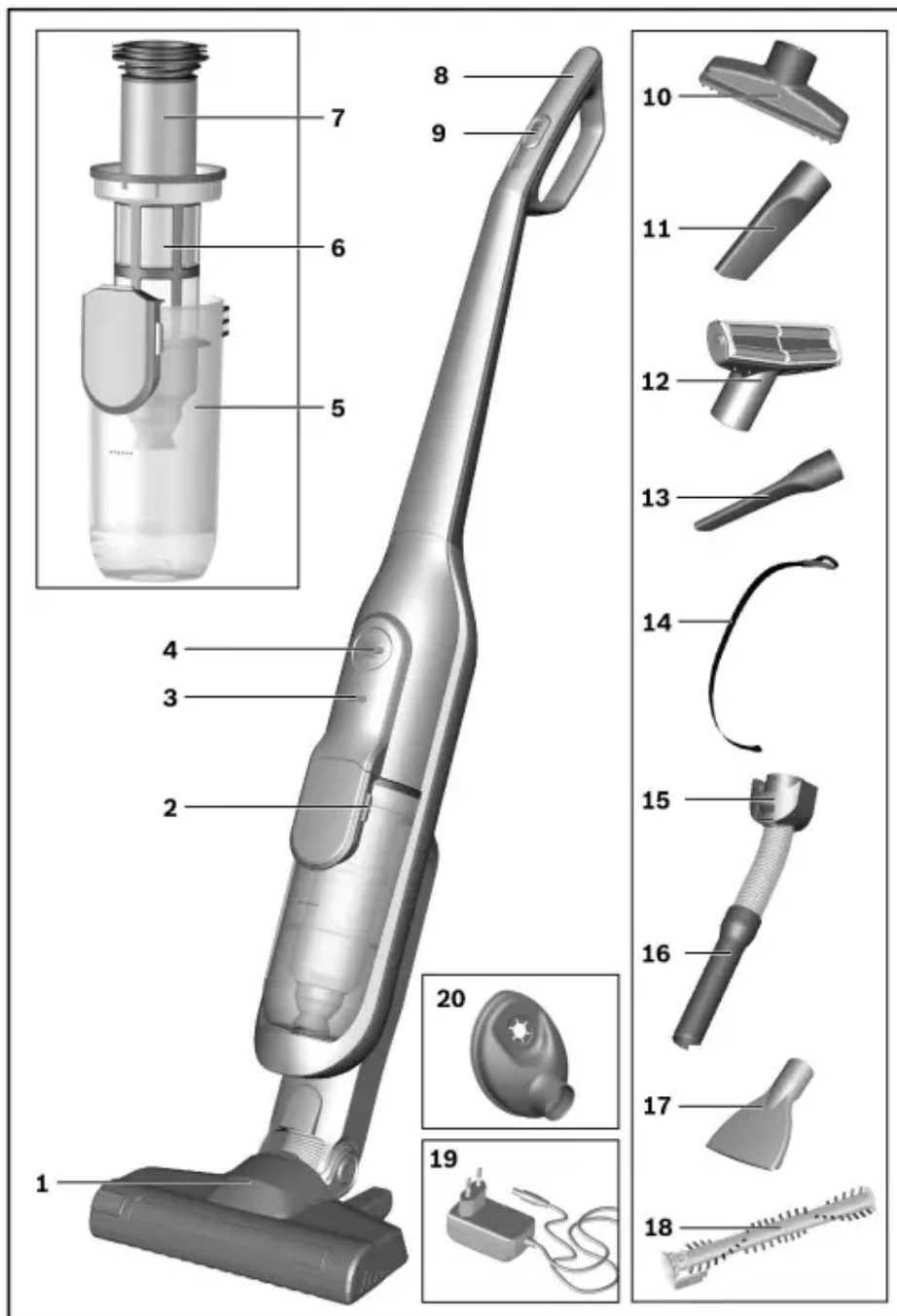

### Intended use

This appliance is intended for domestic use only. This appliance is intended for use up to a maximum height of 2000 metres above sea level. Only use this vacuum cleaner in accordance with the instructions in this instruction manual.

In order to prevent injuries and damage, the vacuum cleaner must not be used for:

- Vacuuming persons or animals.

- Vacuuming up:

- Hazardous, sharp-edged, hot or red-hot substances.
- Damp or liquid substances.
- Highly flammable or explosive substances and gases.
- Ash, soot from tiled stoves and central heating systems.
- Toner dust from printers and copiers.

## Spare parts, accessories

Our original spare parts, original (special) accessories are designed to work with the features and requirements of our vacuum cleaners. We therefore recommend that you only use our original spare parts, original (special) accessories. This will ensure that your vacuum cleaner has a long service life and that the quality of its cleaning performance will remain consistently high throughout.

## Before using your appliance for the first time

Fig. 1

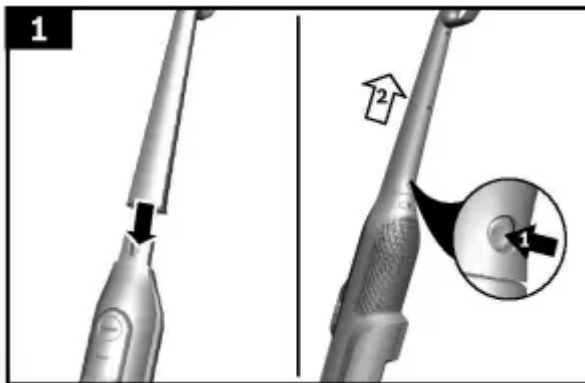

- Carefully plug the handle onto the main housing and lock into place.
- To release the handle, press the release button and carefully lift the handle upwards to remove it.

Fig. 2

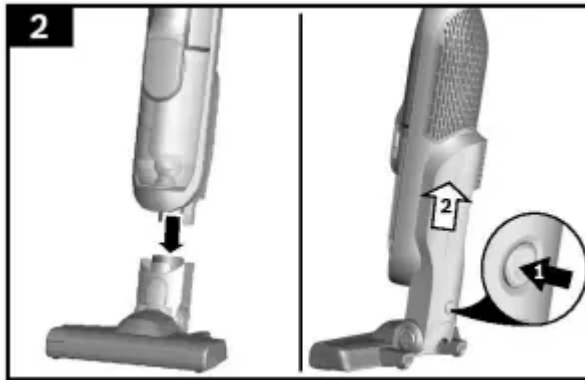

- Plug the hand vacuum cleaner into the floor tool and lock into place.
- To release the floor tool, press the release button and pull the hand vacuum cleaner out of the tool.

## Charging

Caution: Before using the vacuum cleaner for the first time, the batteries must be charged for at least 6 hours.

Fig. 3

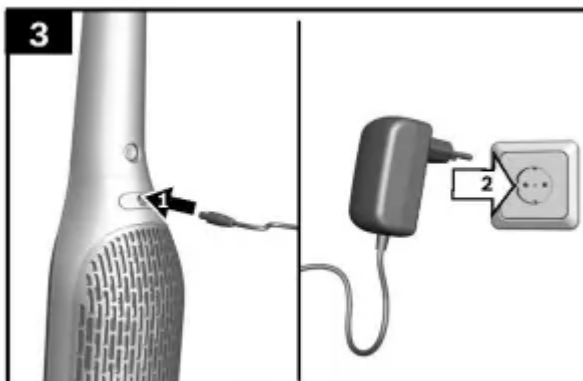

- To charge the vacuum cleaner, place it near to a socket. The appliance can be left standing anywhere in the room. Fig. 7
- Plug the charging cable into the connection at the rear of the appliance.
- Plug the charging cable plug into the socket.
- The charging indicator lashes during the charging process.
- Once the battery is fully charged, the charging indicator lights up in blue and no longer lashes.
- It is normal for the charging cable and hand vacuum cleaner to become hot and not a cause for concern.

### Battery charging status indicator

Fig. 4\*

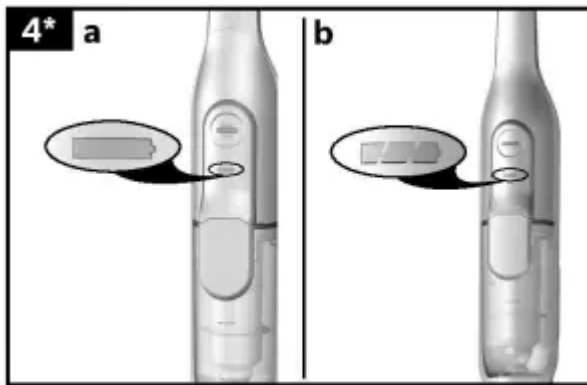



The battery charging status indicator for the appliance corresponds to one of the two following variants:

a) The indicator shows the charging status of the battery.

- Once the battery is fully charged, the indicator lights up in blue. 
- When the indicator lashes, the battery must be recharged.

b) The indicator LEDs show the charging status of the battery.

- Battery fully charged 
- Battery semi-charged 
- Battery low 

When the final LED lashes, the battery must be recharged.

## Vacuuming

Fig. 5

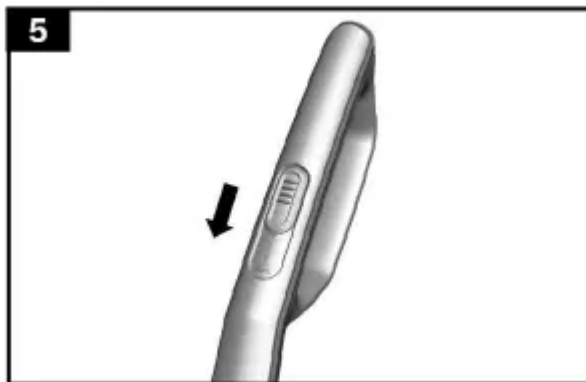

- Move the on/off button in the direction of the arrow.

### Controlling the suction level

Fig. 6

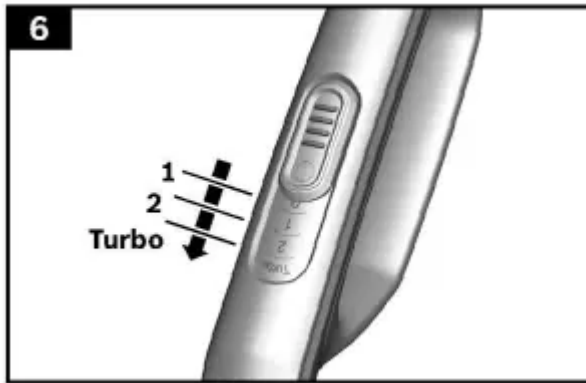

To change the suction power, slide the on/off switch to the desired position:

- Power level 1----- **1**

Vacuuming without the electric brush switched on. For routine cleaning tasks and particularly low operating noise. The appliance achieves the maximum run time at this level.

- Power level 2 -----**2**

Vacuuming at normal power and with the electric brush switched on. For difficult cleaning tasks at an average run time.

\* Depending on model

- Power Level 3 / Turbo Mode -----**3 / Turbo**

Vacuuming at full power and with the electric brush switched on. For stubborn cleaning tasks on all surfaces (carpets, in particular) and when using an optional accessory. The appliance achieves a shorter run time at this level.

## Runtime

The runtime time stated here may vary due to charge status, battery temperature and battery age etc.

	<b>For 1,95Ah battery</b>		
<b>Runtime</b>	<b>Athlet 18V</b>	<b>Athlet 25,2V</b>	<b>Athlet 28V</b>
Level 1:	Up to 40 min.	Up to 60 min.	Up to 65 min.
Level 2:	Up to 30 min.	Up to 30 min.	Up to 30 min.
Level 3 / Turbo mode:	Up to 10 min.	Up to 12 min.	Up to 12 min.

	<b>For 2,6Ah battery</b>	
<b>Runtime</b>	<b>Athlet Runtime Plus 25,2V</b>	<b>Athlet Runtime Plus 28V</b>
Level 1:	Up to 75 min	Up to 80 min.
Level 2	Up to 37 min	Up to 37 min
Level 3 / Turbo mode:	Up to 12 min.	Up to 12 min.

Fig. 7

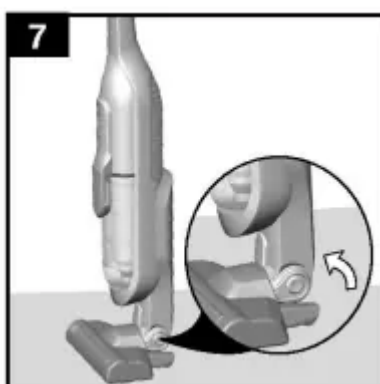

- During short pauses in vacuuming, the appliance can be left standing anywhere in the room. To do this, tilt the vacuum cleaner forwards slightly in the direction of the nozzle.

Caution: When the appliance is left standing, it must be switched off, because if the brush is turning while the appliance is standing still, it could cause damage to the floor covering.

### Vacuuming with accessories

Fig. 8\*

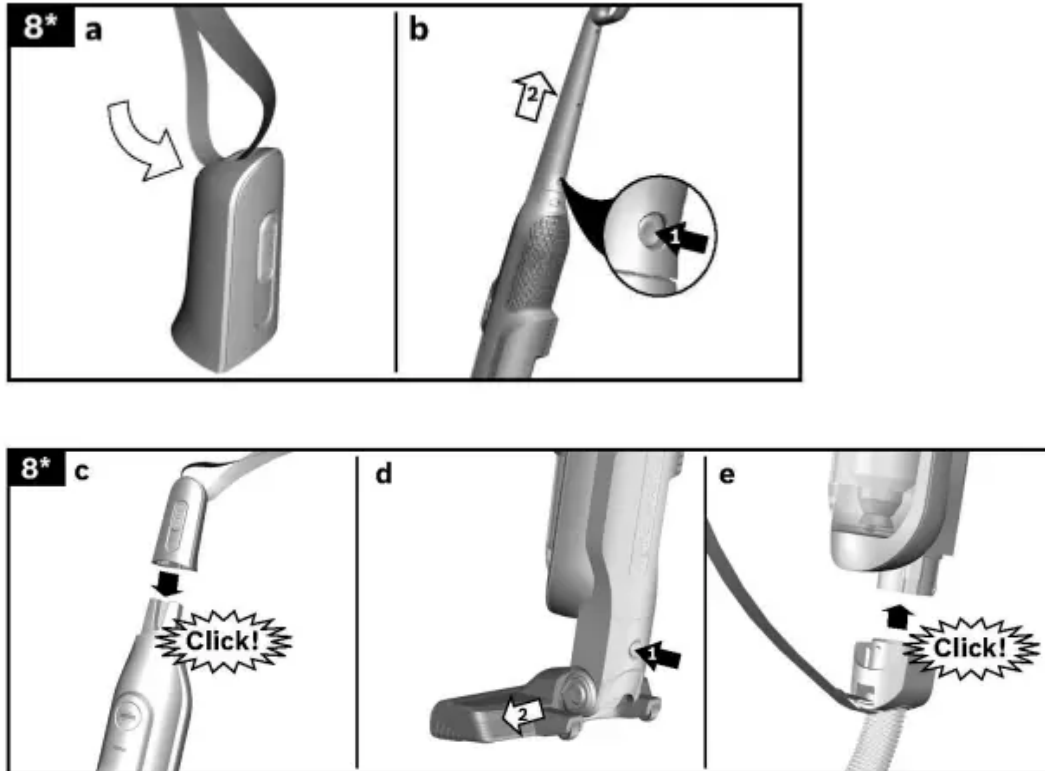

- a) Fasten the carrying strap to the short handle provided.
- b) Remove the long handle from the main housing .
- c) Insert the short handle and lock it in place.
- d) Remove the hand-held vacuum cleaner from the floor nozzle.Fig. 2
- e) Plug the accessory adapter into the hand-held vacuum cleaner and lock it in place.

Fig. 9\*

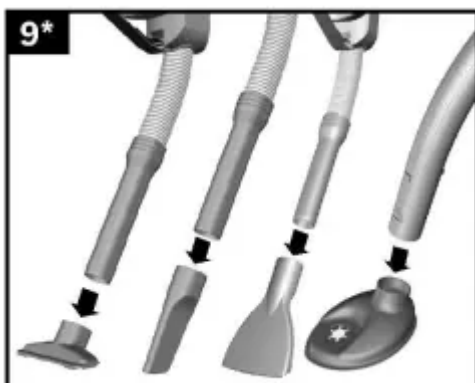

Fit nozzles as required to the flexible hose with the accessory adapter handle:

- Upholstery nozzle for vacuuming upholstered furniture, curtains, etc.
- Crevice nozzle for vacuuming crevices and corners, etc.
- Upholstery crevice nozzle for vacuuming upholstery, ideal for cleaning car seats in particular
- Secure the drill dust nozzle to the handle and then place against the wall, so that the nozzle drill hole opening sits directly over the hole to be drilled.

## After using the appliance

Fig. 10



- Switch off the appliance after vacuuming.

## Emptying the dust container

Fig. 11

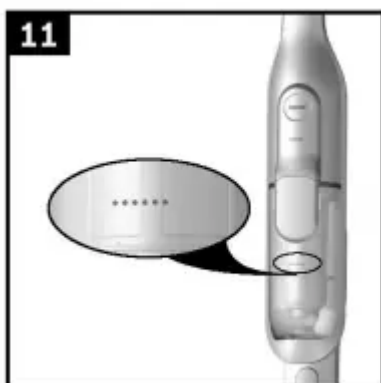

In order to achieve the best possible vacuuming results, the dust container should be emptied after every use or, at the latest, when dust at one point in the dust container has reached the marking.

We recommend that you not fill the dust container beyond the marking, as this leads to considerable soiling of the filter.

When emptying the dust container, always check how dirty the outer filter unit is and, if necessary, clean it as detailed in the "Cleaning the outer filter unit" instructions. Fig. 16

Caution: The filter can only be cleaned if the appliance is switched off.

Never vacuum without the outer filter unit and its fitted filter cartridge.

**Fig. 12**

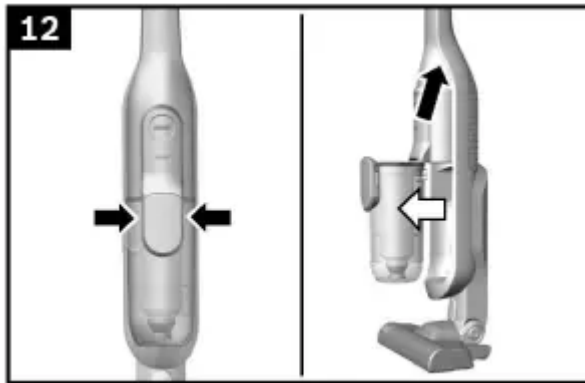

- Using the release button, unlock the dust container and remove it from the appliance.

**Fig. 13**

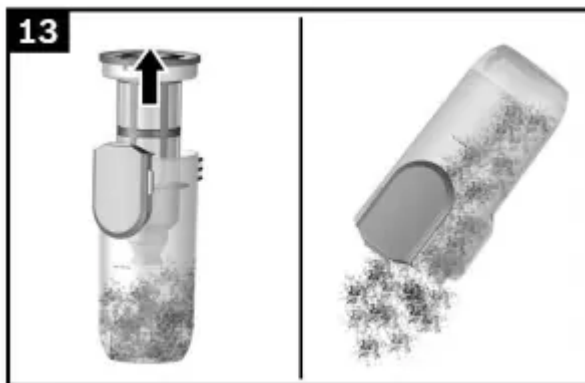

- Take the filter unit out of the dust container.
- Empty the dust container.

**Fig. 14**

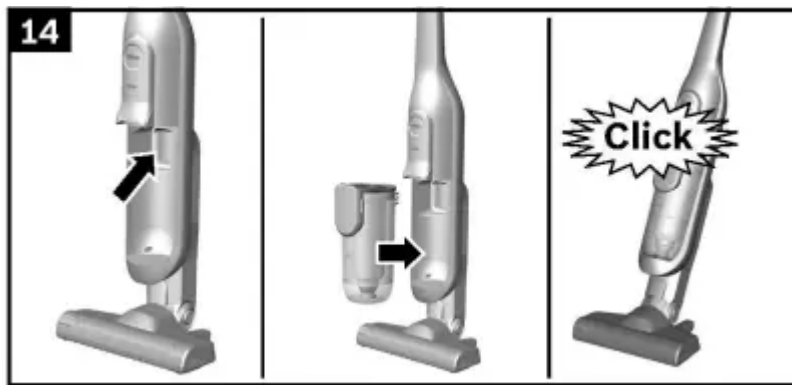

- Remove any dirt which may have been lodged underneath the container ejector opening.
- Insert the filter unit into the dust container, making sure it is correctly seated.
- Insert the dust container in the appliance, so that it 'clicks' audibly into place.

**Caution:** If you notice any resistance when inserting the dust container, check that the filter is complete and that the filter unit and dust container are correctly seated.

## Filter care

Caution: The filter can only be cleaned if the appliance is switched off.

Your appliance is equipped with a "Sensor Control" function.

This function constantly monitors whether your vacuum cleaner is working at its optimum power level. The indicator light lets you know when you need to clean the filter cartridge, so that the appliance can reach its optimum power level once more.

**Fig. 15 Sensor Control**

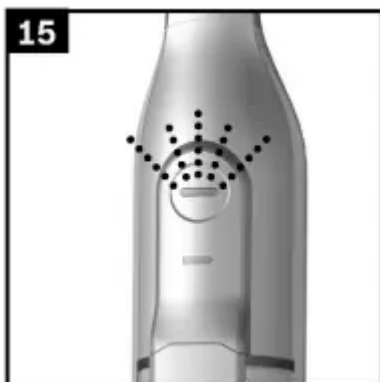

The indicator lights up blue or is off when the appliance is working at its optimum level. Once the indicator turns red and lashes, the outer filter unit and filter cartridge must be cleaned.

The appliance is automatically adjusted to power level 1.

**Fig. 16 Cleaning the outer filter unit**

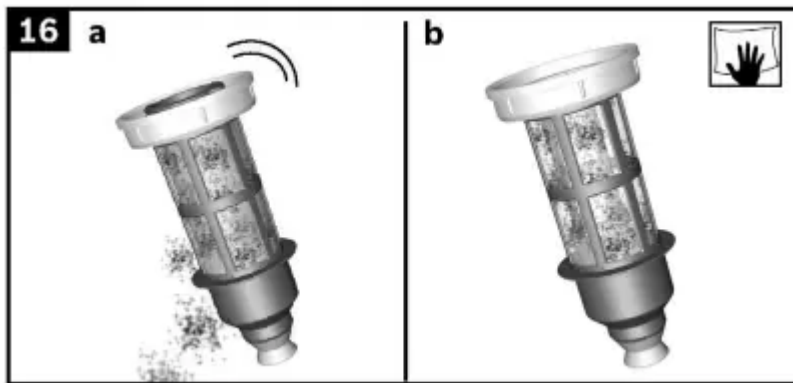

The outer filter unit should be cleaned at regular intervals in order to ensure optimum operation of the vacuum cleaner.

- Please switch off the appliance to clean the outer filter unit.
- Remove the dust container from the appliance. Fig. 12
- Take the filter unit out of the dust container. Fig. 13
- Clean the outer filter unit.

a) It is usually sufficient to lightly shake or tap out the whole filter unit when the dust container is emptied in order to dislodge any particles of dirt.

b) If this is not sufficient, you can use a dry cloth to remove dirt particles from the surface.

**Fig. 17 Cleaning the filter cartridge**

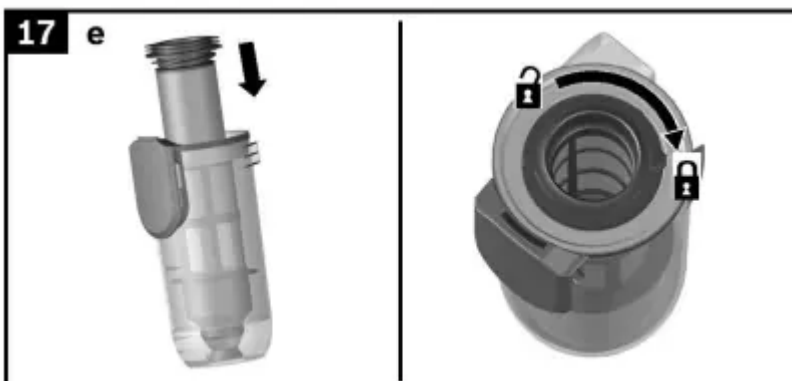
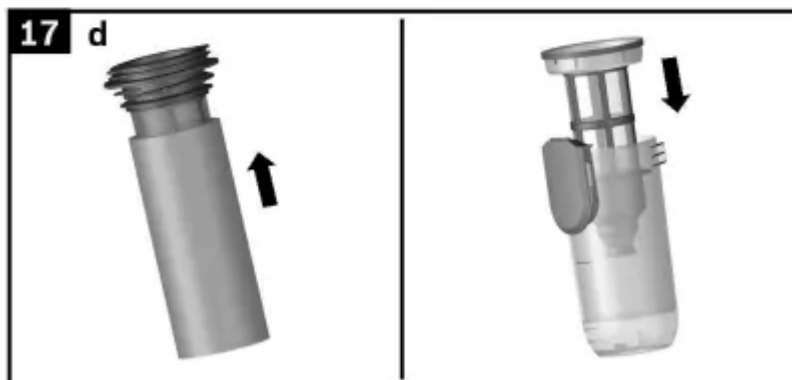
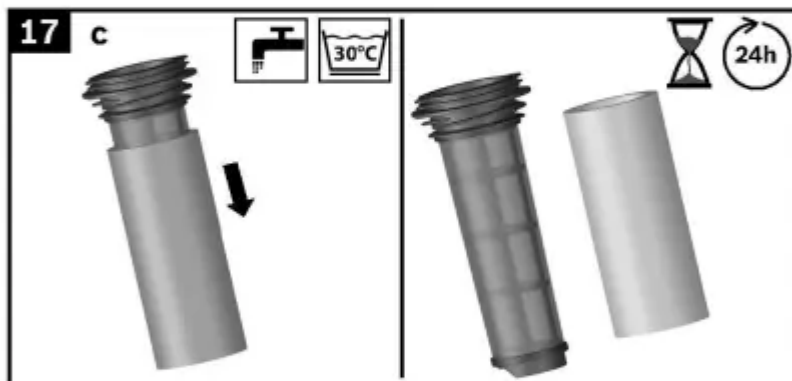
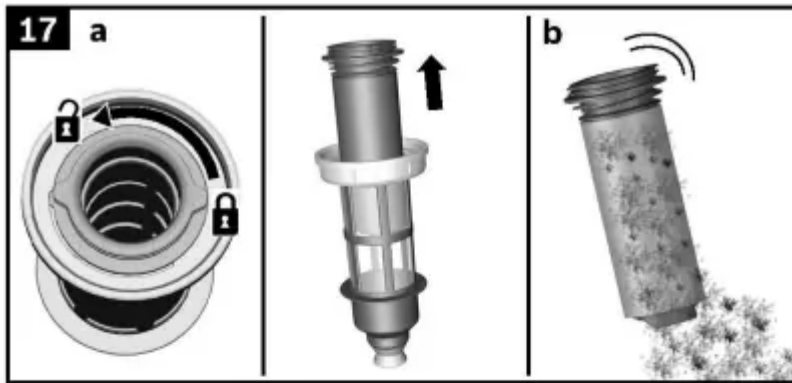

- Switch off the appliance.

- Remove the dust container from the appliance.
  - Fig. 12
  - Take the filter unit out of the dust container. Fig. 13
- a) Turn the filter cartridge lid anti-clockwise and remove the filter cartridge from the filter unit.
  - b) Firstly, clean the filter cartridge by tapping out the dirt.
  - c) Pull out the foam filter from the motor protection and rinse separately. Allow the foam filter and motor protection filter to dry completely (approx. 24 hours)
  - d) After fitting the foam filter, insert the filter cartridge into the dust container.
  - e) Insert the filter cartridge into the filter unit and lock it by turning the lid clockwise.

If, after hand-washing the filter cartridge, the "Sensor Control" indicator lashes red again, the filter cartridge is so heavily soiled that it must be washed in a washing machine. Use a gentle programme at max. 30 °C and the lowest spin speed.

New filters can be obtained from our after-sales service, if required.

## **Cleaning the floor tool**

Before carrying out any maintenance, switch off the vacuum cleaner and disconnect it from the charging cable.

**Fig. 18**

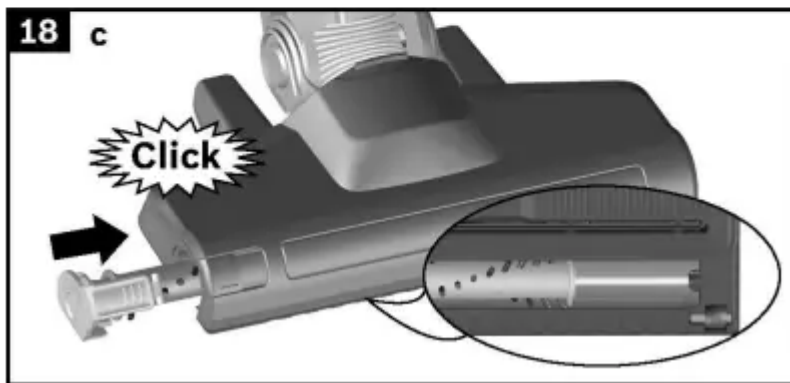
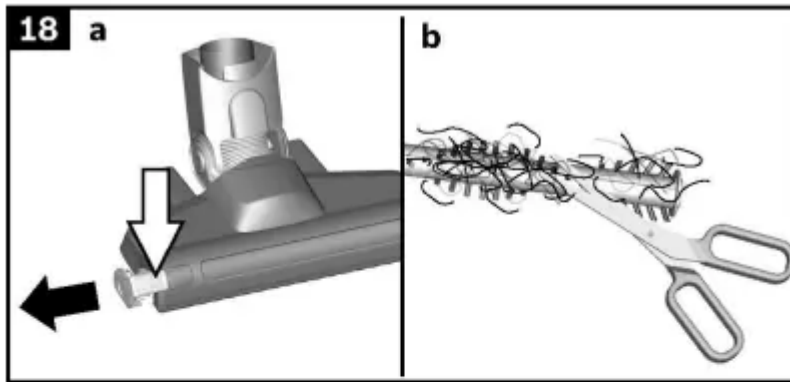

- a) Release the brush roller using the release button and pull it sideways out of the floor tool.
- b) Using the groove provided, cut through threads and hairs wound round the rollers with scissors and then remove them.
- c) Push the brush roller in sideways along the guide rod in the floor tool and lock in place using the release button.

Caution: The floor tool must only be put into operation with the brush roller fitted.

## Care

Before cleaning the hand vacuum cleaner, it must be switched off and disconnected from the charging cable. The vacuum cleaner and plastic accessories can be cleaned with an ordinary plastic cleaner.

**Caution:** Do not use abrasive materials, glass cleaning agents or all-purpose cleaning products. Never immerse the vacuum cleaner in water.

Subject to technical modifications.

## Safety information

This vacuum cleaner complies with the recognized rules of technology and the relevant safety regulations.

- The appliance may be used by children over the age of 8 years and by persons with reduced physical, sensory or mental capacity or by persons with a lack of experience or knowledge if they are supervised or have been instructed on the safe use of the appliance and have understood the potential dangers of using the appliance.
- Children must never play with the appliance.
- Cleaning and user maintenance must never be carried out by children without supervision.
- Plastic bags and films must be kept out of the reach of children and disposed of.

>= There is a risk of suffocation.

### Proper use

- To charge, only use the charging cable included in the scope of supply.
- The charging cable must only be connected and operated as specified on the rating plate.
- The appliance must only be stored and charged indoors.
- Do not expose the appliance to temperatures below 0 °C or above 40 °C.
- Never vacuum without the dust bag or dust container, motor protection or exhaust filter.

>= This may damage the vacuum cleaner.

- Keep the vacuum cleaner away from your head when using nozzles and tubes.

=> This could cause injury.

- Do not use a damaged charging cable. Replace it with an original charging cable.
- When disconnecting the charging cable from the mains, pull the plug itself to remove it; do not pull on the power cord.
- Do not pull the charging cable over sharp edges or allow it to become trapped.
- Before carrying out any work on the vacuum cleaner, switch off the appliance and disconnect it from the charging cable and the mains.
- Do not operate the vacuum cleaner if it is damaged.
- If a fault is detected, switch off the appliance and disconnect it from the charging cable and the mains.
- For safety reasons, only authorized after-sales service personnel are permitted to carry out repairs and replacement parts to the vacuum cleaner.

- In the following cases, you must stop the appliance immediately and contact the after-sales service:

– If you have accidentally vacuumed up some liquid or liquid has entered the inside of the appliance;

– If the appliance has been dropped and damaged.

- Protect the vacuum cleaner from outside weather conditions, moisture and sources of heat.
- Do not pour flammable substances or substances containing alcohol onto the filters (dust bag, motor protection filter, exhaust filter, etc.).
- The vacuum cleaner is not suitable for use on construction sites.

=> Vacuuming up building rubble may damage the appliance.

- Switch off the appliance when it is not in use.
- The packaging is designed to protect the vacuum cleaner from being damaged during transportation. We, therefore, recommend keeping the packaging for the purpose of future transportation.

## Batteries

Your appliance is fitted with lithium-ion batteries which, for safety reasons, are only accessible to professional repair specialists.

For battery replacement, please contact your nearest after-sales centre or an authorized specialist dealer.

## Notes on transport

The lithium-ion batteries in the appliance are subject to the requirements of dangerous goods legislation. The batteries can be transported by the user by road without any further requirements. In the event that they are dispatched by a third party (e.g. transported by air or freight carrier), special requirements regarding packaging and identification must be met. In this case, a dangerous goods expert must be consulted when preparing the goods for dispatch.

### Warning

This content is compiled from multiple sources and is provided for reference purposes only. It may not be complete or fully applicable to all situations. If you are unable to resolve your issue, please contact the product manufacturer or an authorized service provider for official support.