

INSTALLATION INSTRUCTIONS for Commercial Stacked Washer/ Dryer

TOOLS & PARTS

Tools Needed:



8" (203 mm) or 10" (254 mm)
Pipe Wrench



8" (203 mm) or 10" (254 mm)
Adjustable Wrench That Opens
to 1" (25 mm)



Flat-Blade Screwdriver



Phillips Screwdriver



Torx® T-20 Security
Screwdriver or Bit



1" (25 mm) Hex-Head
Socket Wrench



5/16" Socket Wrench



Pliers
(that open to 1 9/16" [39 mm])



Level



Utility Knife



1/4" (6 mm) Nut Driver



Locking Pliers

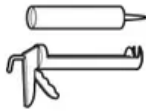

Caulk Gun and Caulk
(for installing new exhaust vent)



Vent Clamps



Pipe-Joint Compound
Suitable for Gas Type



27" (686 mm) Wood Block



Flashlight (optional)



1/2" (13 mm) and 9/16"
(14 mm) Open-End Wrenches



Ruler or Measuring Tape

Parts Supplied:



Water Inlet Hoses (2)



Inlet Hose Washers (4)



U-Shaped Hose Form



Transit Bolt Hole Plug (4)



Beaded Tie Strap



Drain Hose/Clamp

ALTERNATE PARTS AND ACCESSORIES

Alternate Parts

Your installation may require additional parts. If you are interested in purchasing one of the items listed here, call the toll-free number in the "If You Need Assistance" section.

If You Have:	You Will Need to Buy:
Overhead sewer	Standard 20 gal. (76 L) 39" (990 mm) tall drain tub or utility sink, sump pump, and connectors (available from local plumbing suppliers)
1" (25 mm) standpipe	2" (51 mm) diameter to 1" (25 mm) diameter Standpipe Adapter, Part Number 3363920 Connector Kit Part Number 285835
Drain hose too short	Extension Drain Hose, Part Number 285863 Connector Kit Part Number 285835
Lint clogged Drain	Drain Protector, Part Number 367031 Connector Kit Part Number 285835
Floor drain system	Siphon break, Part Number 285834 Connector Kit (x2) Part Number 285835 Extension Drain Hose, Part Number 285863
Water faucets beyond reach of fill hoses	Two longer water fill hoses: 6 ft. (1.8 m) 90° bend hose, Part Number 76314 10 ft. (3.0 m), Part Number 350008



Accessories

Part Number	Accessory
8212526	Washer drip tray, fits under all
31682	All-purpose appliance cleaner
1903WH	Laundry supply storage cart
279818	3-way dryer venting kit
285834	Siphon break kit

DIMENSIONS/CLEARANCES

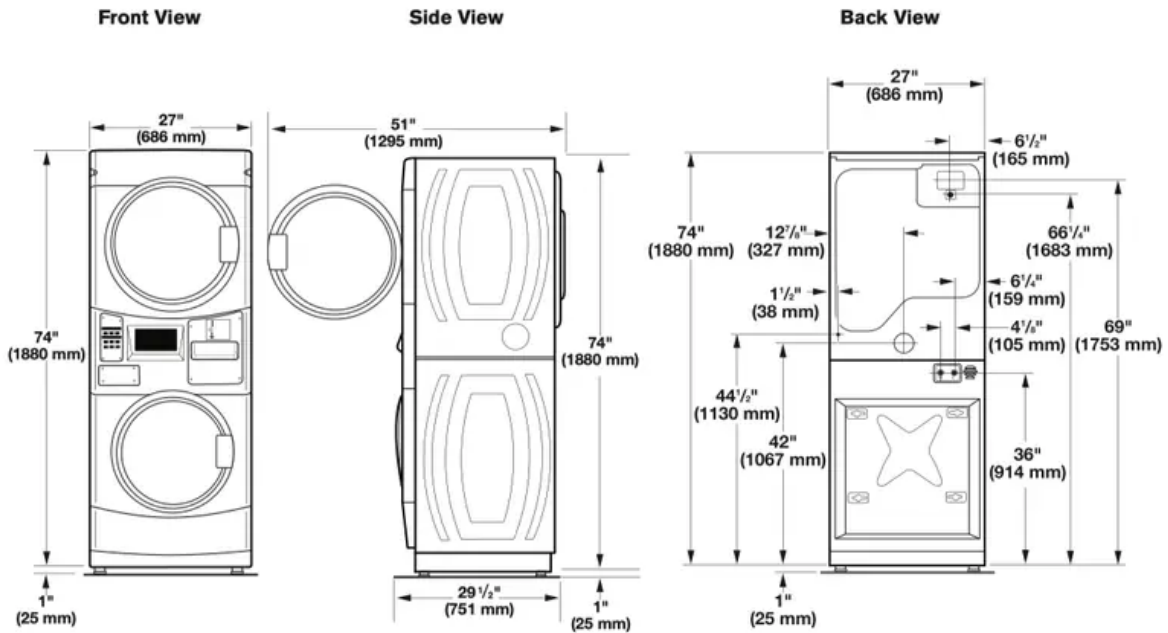

Clearances

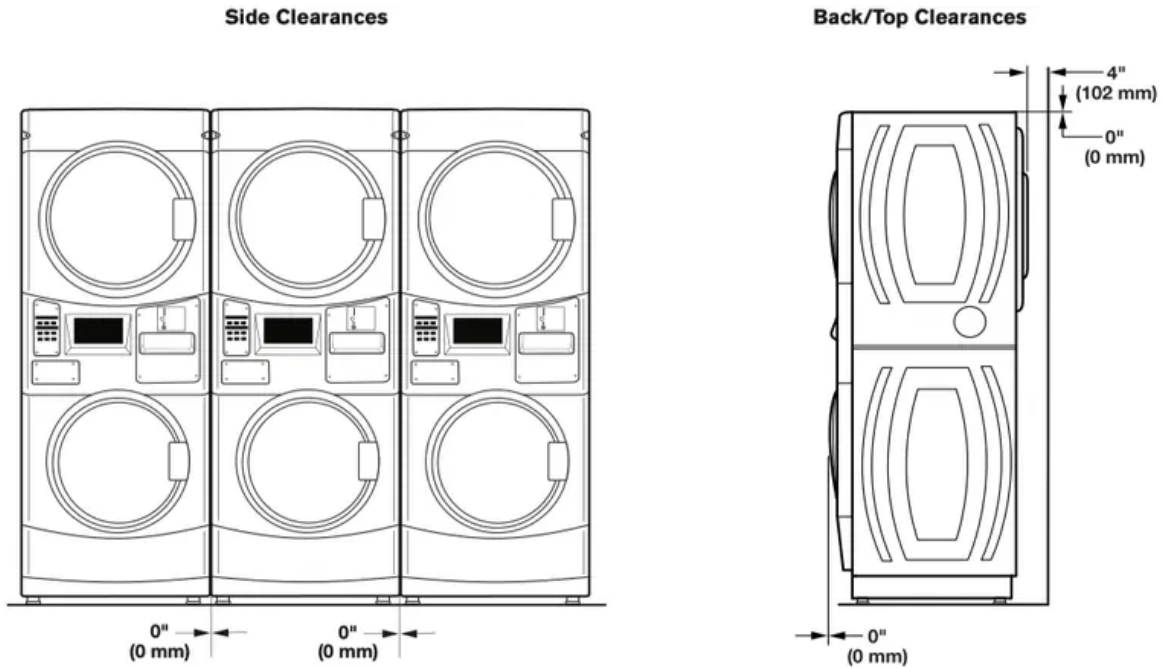

STACKED WASHER/GAS DRYER INSTALLATION REQUIREMENTS

Stacked Washer/Gas Dryer Location

⚠ WARNING



Explosion Hazard

Keep flammable materials and vapors, such as gasoline, away from dryer.

Do not install in a garage.

Failure to do so can result in death, explosion, or fire.

Selecting the proper location for your washer/dryer improves performance and minimizes noise and possible washer "walk."

Your washer/dryer can be installed in a basement, laundry room, or recessed area. This washer/dryer is not intended for install in a mobile home or recreational vehicle. See the “Drain System” section for more information.

Companion appliance location requirements should also be considered.

IMPORTANT: Do not install or store the washer/dryer where it will be exposed to the weather. Do not store or operate the washer/dryer in temperatures at or below 32°F (0°C). Some water can remain in the washer and can cause damage in low temperatures. Proper installation is your responsibility.

You will need:

- A water heater set to deliver 120°F (49°C) water to the washer.
- A grounded electrical outlet located within 6 ft. (1.8 m) of where the power cord is attached to the back of the washer. See the “Electrical Requirements” section.
- Hot and cold water faucets located within 4 ft. (1.2 m) of the hot and cold water fill valves, and water pressure of 20–100 psi (137.9–689.6 kPa).
- A level floor with a maximum slope of 1" (25 mm) under entire washer/dryer. Installing the washer/dryer on soft floor surfaces, such as carpets or surfaces with foam backing, is not recommended.
- A sturdy and solid floor to support the washer/dryer with a total weight (water and load) of 450 lbs (204 kg).
- A floor drain under the bulkhead. Prefabricated bulkheads with electrical outlets, water inlet lines, and drain facilities should be used only where local codes permit.

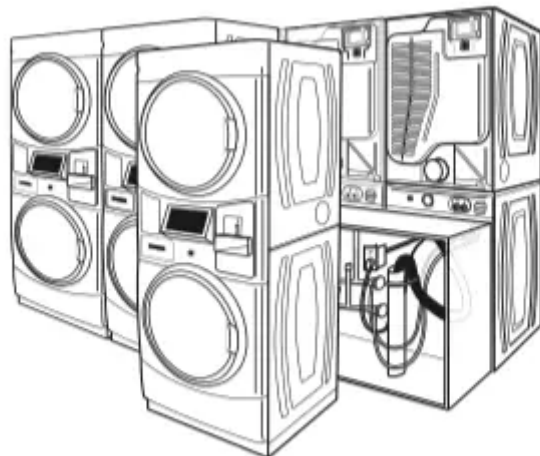

Stacked washer/gas dryer installation clearances:

- The location must be large enough to allow the washer and dryer doors to be fully opened.
- Additional spacing should be considered for ease of installation and servicing. The doors open more than 180°. The washer door is not reversible.

- Additional clearances might be required for wall, door, and floor moldings.
- Additional spacing of 1" (25 mm) on all sides of the washer/ dryer is recommended to reduce noise transfer and to improve spin-up performance of the washer.
- Companion appliance spacing should also be considered.

When installing a gas dryer:

IMPORTANT: Observe all governing codes and ordinances.

- Check code requirements: Some codes limit or do not permit installation of clothes dryers in garages, closets, or sleeping quarters. Contact your local building inspector.
- Make sure that lower edges of the cabinet, plus the back and bottom sides of the washer, are free of obstructions to permit adequate clearance of air openings for combustion air. See the "Recessed Area and Closet Installation Instructions" below for minimum spacing requirements.

Recessed Area Installation Instructions

This washer/dryer may be installed in a recessed area. For recessed area installations, minimum clearances can be found on the warning label on the rear of the dryer or in the "Dimensions/ Clearances" section.

The installation spacing is in inches and is the minimum allowable. Additional spacing should be considered for ease of installation, servicing, and compliance with local codes and ordinances.

NOTE: The dryer must be exhausted outdoors.

Stacked Washer/Gas Dryer Electrical Requirements

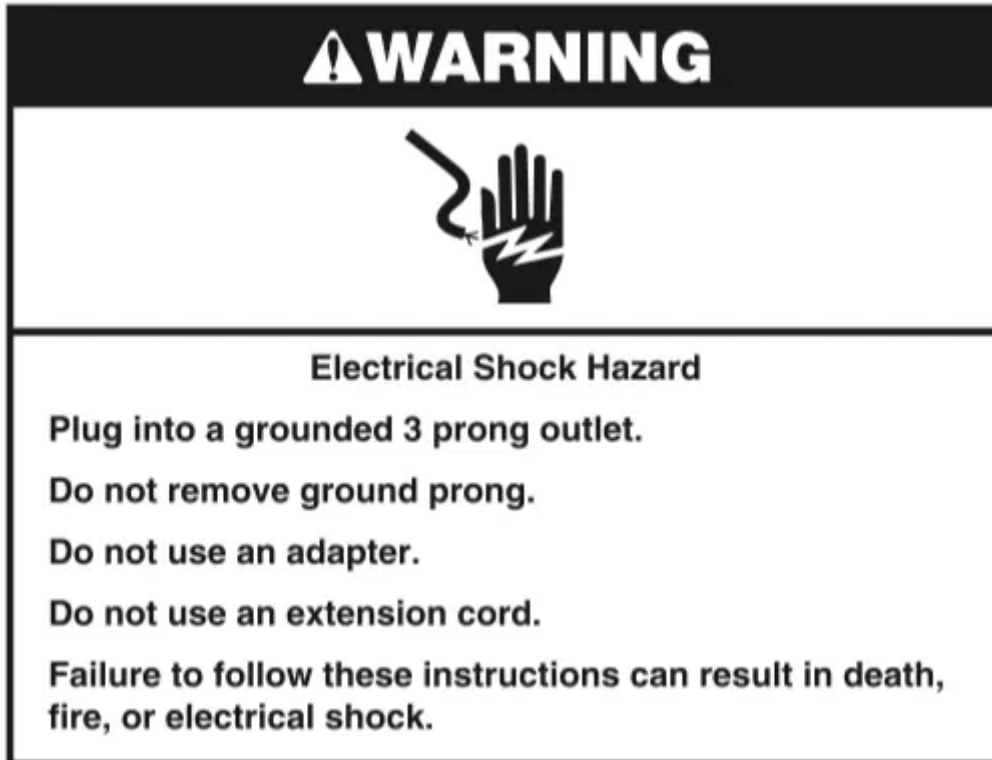

IMPORTANT: The washer/dryer must be electrically grounded in accordance with local codes and ordinances or, in the absence of local codes, with the National Electrical Code, ANSI/NFPA 70, latest edition, or Canadian Electrical Code, CSA C22.1. If codes permit and a separate ground wire is used, it is recommended that a qualified electrical installer determine that the ground path is adequate.

- Do not ground to a gas pipe.
- Do not have a fuse in the neutral or ground circuit.
- A 120 volt, 60 Hz, AC only, 15- or 20-amp, fused electrical circuit is required. A time-delay fuse or circuit breaker is also recommended. It is recommended that a separate circuit serving only this washer/dryer be provided.
- This washer/dryer is equipped with a power supply cord having a 3 prong grounding plug.
- To minimize the possibility of shock, the cord must be plugged into a mating, 3 prong, grounding-type outlet, grounded in accordance with local codes and ordinances. If a mating outlet is not available, it is the personal responsibility and obligation of the customer to have the properly grounded outlet installed by a qualified electrician.
- If codes permit and a separate ground wire is used, it is recommended that a qualified electrician determine that the ground path is adequate.
- Check with a qualified electrician if you are not sure the washer/dryer is properly grounded.

Stacked Washer/Gas Dryer Grounding

GROUNDING INSTRUCTIONS

For a grounded, cord-connected washer:

This washer must be grounded. In the event of a malfunction or breakdown, grounding will reduce the risk of electrical shock by providing a path of least resistance for electric current. This washer is equipped with a cord having an equipment-grounding conductor and a grounding plug. The plug must be plugged into an appropriate outlet that is properly installed and grounded in accordance with all local codes and ordinances.

WARNING: Improper connection of the equipment-grounding conductor can result in a risk of electric shock. Check with a qualified electrician or serviceman if you are in doubt as to whether the appliance is properly grounded.

Do not modify the plug provided with the appliance – if it will not fit the outlet, have a proper outlet installed by a qualified electrician.

For a permanently connected washer:

This washer must be connected to a grounded metal, permanent wiring system, or an equipment grounding conductor must be run with the circuit conductors and connected to the equipment-grounding terminal or lead on the appliance.

GROUNDING INSTRUCTIONS

■ For a grounded, cord-connected dryer:

This dryer must be grounded. In the event of malfunction or breakdown, grounding will reduce the risk of electric shock by providing a path of least resistance for electric current. This dryer uses a cord having an equipment-grounding conductor and a grounding plug. The plug must be plugged into an appropriate outlet that is properly installed and grounded in accordance with all local codes and ordinances.

■ For a permanently connected dryer:

This dryer must be connected to a grounded metal, permanent wiring system, or an equipment-grounding conductor must be run with the circuit conductors and connected to the equipment-grounding terminal or lead on the dryer.

WARNING: Improper connection of the equipment-grounding conductor can result in a risk of electric shock. Check with a qualified electrician or service representative or personnel if you are in doubt as to whether the dryer is properly grounded. Do not modify the plug on the power supply cord: if it will not fit the outlet, have a proper outlet installed by a qualified electrician.

SAVE THESE INSTRUCTIONS

Stacked Washer/Gas Dryer Gas Supply

WARNING Explosion Hazard Use a new CSA International approved gas supply line. Install a shut-off valve.

Securely tighten all gas connections.

If connected to propane, have a qualified person make sure gas pressure does not exceed 13" (33 cm) water column.

Examples of a qualified person include: licensed heating personnel, authorized gas company personnel, and authorized service personnel.

Failure to do so can result in death, explosion, or fire.

IMPORTANT: Observe all governing codes and ordinances. This installation must conform with all local codes and ordinances. In the absence of local codes, installation must conform with American National Standard, National Fuel Gas Code ANSI Z223.1/NFPA 54 or CAN/CSA B149.

The design of this washer/dryer has been certified by CSA International for use at altitudes up to 10,000 feet (3,048 m) above sea level at the B.T.U. rating indicated on the model/serial plate.

Burner input adjustments are not required when the washer/dryer is operated up to this elevation.

When installed above 10,000 feet (3,048 m), a four percent (4%) reduction of the burner B.T.U. rating shown on the model/serial plate is required for each 1,000 foot (305 m) increase in elevation. For assistance when converting to other gas types and/or installing above 10,000 feet (3,048 m) elevation, contact your local service company.

Stacked Washer/Electric Dryer Location

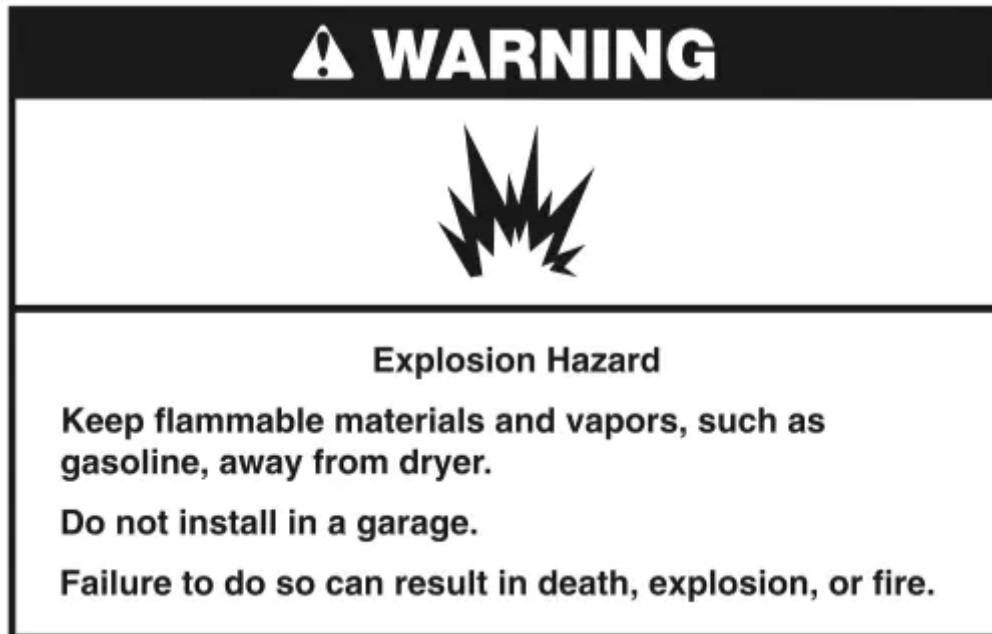

Selecting the proper location for your washer/dryer improves performance and minimizes noise and possible washer “walk.”

Your washer/dryer can be installed in a basement, laundry room, or recessed area. This washer/dryer is not intended for install in a mobile home or recreational vehicle. See the “Drain System” section.

Companion appliance location requirements should also be considered.

IMPORTANT: Do not install or store the washer/dryer where it will be exposed to the weather. Do not store or operate the washer/dryer in temperatures at or below 32°F (0°C). Some water can remain in the washer and can cause damage in low temperatures. Proper installation is your responsibility.

You will need:

- A water heater set to deliver 120°F (49°C) water to the washer.
- A grounded electrical outlet located within 6 ft. (1.8 m) of where the power cord is attached to the back of the washer. See “Electrical Requirements.”
- Hot and cold water faucets located within 4 ft. (1.2 m) of the hot and cold water fill valves, and water pressure of 20–100 psi (137.9–689.6 kPa).

- A level floor with a maximum slope of 1" (25 mm) under entire washer/dryer. Installing the washer/dryer on soft floor surfaces, such as carpets or surfaces with foam backing, is not recommended.
- A sturdy and solid floor to support the washer/dryer with a total weight (water and load) of 450 lbs (204 kg).
- A floor drain under the bulkhead. Prefabricated bulkheads with electrical outlets, water inlet lines, and drain facilities should be used only where local codes permit.

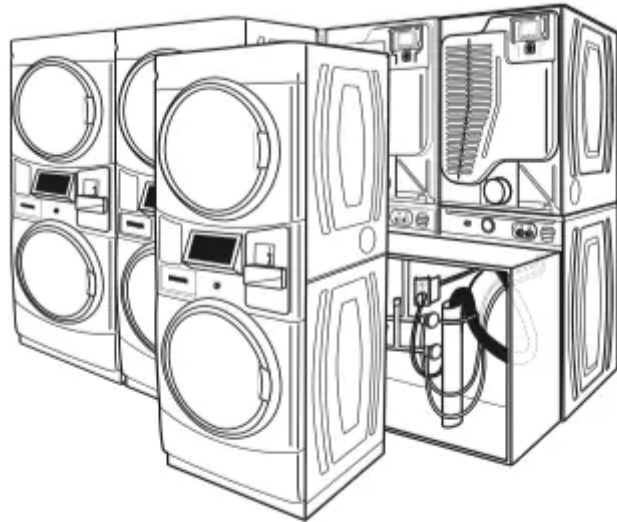

Stacked washer/electric dryer installation clearances

- The location must be large enough to allow the washer and dryer doors to be fully opened.
- Additional spacing should be considered for ease of installation and servicing. The doors open more than 180°. The washer door is not reversible.
- Additional clearances might be required for wall, door, and floor moldings.
- Additional spacing of 1" (25 mm) on all sides of the washer/ dryer is recommended to reduce noise transfer, and improve spin-up performance of washer.
- Companion appliance spacing should also be considered.

Recessed Area and Closet Installation Instructions

This washer/dryer may be installed in a recessed area or closet. For recessed area and closet installations, minimum clearances can be found on the warning label on the rear of the dryer.

The installation spacing is in inches and is the minimum allowable. Additional spacing should be considered for ease of installation, servicing, and compliance with local codes and ordinances.

NOTE: The dryer must be exhausted outdoors.

Stacked Washer/Electric Dryer Electrical Requirements

Washer Electrical Requirements

⚠ WARNING



Electrical Shock Hazard

Plug into a grounded 3 prong outlet.

Do not remove ground prong.

Do not use an adapter.

Do not use an extension cord.

Failure to follow these instructions can result in death, fire, or electrical shock.

- Do not have a fuse in the neutral or ground circuit.
- This washer/dryer is equipped with a power supply cord having a 3 prong grounding plug.
- To minimize the possibility of shock, the cord must be plugged into a mating, 3 prong, grounding-type outlet, grounded in accordance with local codes and ordinances. If a mating outlet is not available, it is the personal responsibility and obligation of the customer to have the properly grounded outlet installed by a qualified electrician.
- If codes permit and a separate ground wire is used, it is recommended that a qualified electrician determine that the ground path is adequate.
- Check with a qualified electrician if you are not sure the washer is properly grounded.

Dryer Electrical Requirements

It is your responsibility:

- To contact a qualified electrical installer.
- To be sure that the electrical connection is adequate and in conformance with the National Electrical Code, ANSI/NFPA 70-latest edition and all local codes and ordinances.
- The National Electrical Code requires a 4-wire power supply connection for homes built after 1996, dryer circuits involved in remodeling after 1996, and all mobile home installations.
- A copy of the above code standards can be obtained from: National Fire Protection Association, One Batterymarch Park, Quincy, MA 02269.

- To supply the required 3- or 4-wire, single phase, 240 volt, 60 Hz., AC only electrical supply (or 3 or 4 wire, 120/208 volt electrical supply, if specified on the serial/rating plate) on a separate 30 amp circuit, fused on both sides of the line. A time delay fuse or circuit breaker is recommended. Connect to an individual branch circuit. Do not have a fuse in the neutral or grounding circuit.
- Do not use an extension cord.
- If codes permit and a separate ground wire is used, it is recommended that a qualified electrician determine that the ground path is adequate.

Electrical Connection

To properly install your dryer, you must determine the type of electrical connection you will be using and follow the instructions provided for it here.

- This dryer is manufactured ready to install with a 3-wire electrical supply connection. The neutral ground conductor is permanently connected to the neutral conductor (white wire) within the dryer. If the dryer is installed with a 4-wire electrical supply connection, the neutral ground conductor must be removed from the external ground connector (green screw), and secured under the neutral terminal (center or white wire) of the terminal block. When the neutral ground conductor is secured under the neutral terminal (center or white wire) of the terminal block, the dryer cabinet is isolated from the neutral conductor.
- If local codes do not permit the connection of a neutral ground wire to the neutral wire, see the “Optional 3-wire connection” section.
- A 4-wire power supply connection must be used when the appliance is installed in a location where grounding through the neutral conductor is prohibited. Grounding through the neutral is prohibited for (1) new branch-circuit installations, (2) mobile homes, (3) recreational vehicles, and (4) areas where local codes prohibit grounding through the neutral conductor.

Electric Dryer Power Supply Cord

⚠ WARNING



Fire Hazard

Use a new UL listed 30 amp power supply cord.

Use a UL listed strain relief.

Disconnect power before making electrical connections.

Connect neutral wire (white or center wire) to center terminal.

Ground wire (green or bare wire) must be connected to green ground connector.

Connect remaining 2 supply wires to remaining 2 terminals (gold).

Securely tighten all electrical connections.

Failure to do so can result in death, fire, or electrical shock.

If using a power supply cord:

Use a UL listed power supply cord kit marked for use with clothes dryers. The kit should contain:

- A UL listed 30 amp power supply cord, rated 240 volt minimum. The cord should be type SRD or SRDT and be at least 4 ft. (1.22 m) long. The wires that connect to the dryer must end in ring terminals or “U” shaped spade terminals with upturned ends.
- A UL listed strain relief.

If your outlet looks like this:



**4-wire
receptacle
(14-30R)**

Then choose a 4-wire power supply cord with ring or spade terminals and UL listed strain relief. The 4-wire power supply cord, at least 4 ft. (1.22 m) long, must have four 10-gauge copper wires and match a 4-wire receptacle of NEMA Type 14-30R. The ground wire (ground conductor) may be either green or bare. The neutral conductor must be identified by a white cover.

If your outlet looks like this:



Then choose a 3-wire power supply cord with ring or spade terminals and UL listed strain relief. The 3-wire power supply cord, at least 4 ft. (1.22 m) long, must have three 10-gauge copper wires and match a 3-wire receptacle of NEMA Type 10-30R.

Dryer Direct Wire

WARNING Fire Hazard

Use 10 gauge copper wire.

Use a UL listed strain relief.

Disconnect power before making electrical connections. Connect neutral wire (white or center wire) to center terminal.

Ground wire (green or bare wire) must be connected to green ground connector.

Connect remaining 2 supply wires to remaining 2 terminals (gold).

Securely tighten all electrical connections.

Failure to do so can result in death, fire, or electrical shock.

If connecting by direct wire:

Power supply cable must match power supply (4-wire or 3-wire) and be:

- Flexible armored cable or nonmetallic sheathed copper cable (with ground wire), covered with flexible metallic conduit. All current-carrying wires must be insulated.
- 10-gauge solid copper wire (do not use aluminum).
- At least 5 ft. (1.52 m) long.

DRYER VENTING REQUIREMENTS

WARNING: To reduce the risk of fire, this dryer must be exhausted outdoors.

IMPORTANT: Observe all governing codes and ordinances.

Dryer exhaust must not be connected into any gas vent, chimney, wall, ceiling, attic, crawlspace, or a concealed space of a building. Only rigid or flexible metal vent shall be used for exhausting.

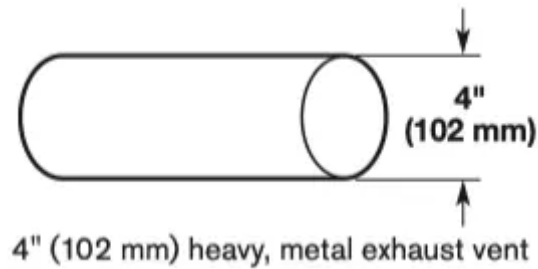

- Only a 4" (102 mm) heavy, metal exhaust vent and clamps may be used.
- Do not use plastic or metal foil vent.

Rigid metal vent:

- Recommended for best drying performance and to avoid crushing and kinking.

Flexible metal vent: (Acceptable only if accessible to clean)

- Must be fully extended and supported in final dryer location.
- Remove excess to avoid sagging and kinking that may result in reduced airflow and poor performance.
- Do not install in enclosed walls, ceilings, or floors.
- The total length should not exceed 7 3/4 ft. (2.4 m).

NOTE: If using an existing vent system, clean lint from entire length of the system and make sure exhaust hood is not plugged with lint. Replace plastic or metal foil vents with rigid metal or flexible metal vents. Review the "Vent System Chart" and if necessary, modify existing vent system to achieve best drying performance.

Elbows:

- 45° elbows provide better airflow than 90° elbows.

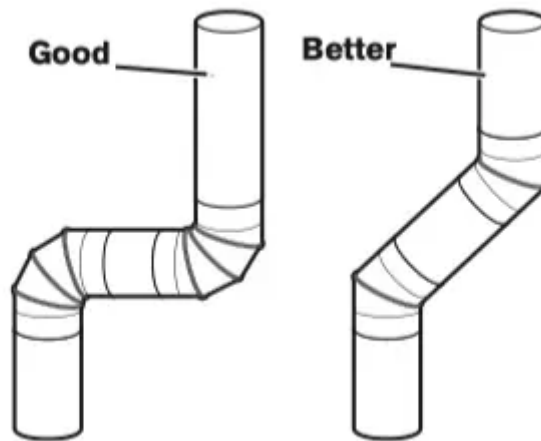

Clamps:

- Use clamps to seal all joints.
- Exhaust vent must not be connected or secured with screws or other fastening devices that extend into interior of duct and catch lint. Do not use duct tape.

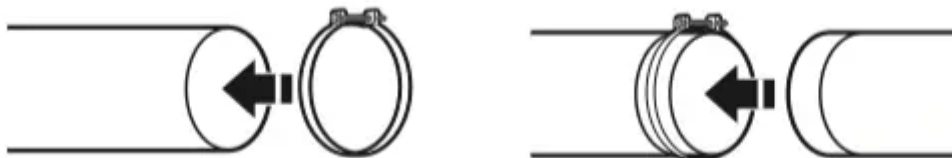

Vent Hoods

4" (102 mm) Diameter Exhaust Hoods



box hood

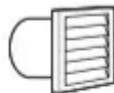

louvered hood



angled hood

Exhaust hood must be at least 12" (305 mm) from the ground or any object that may be in the path of the exhaust (such as flowers, rocks, bushes, or snow).

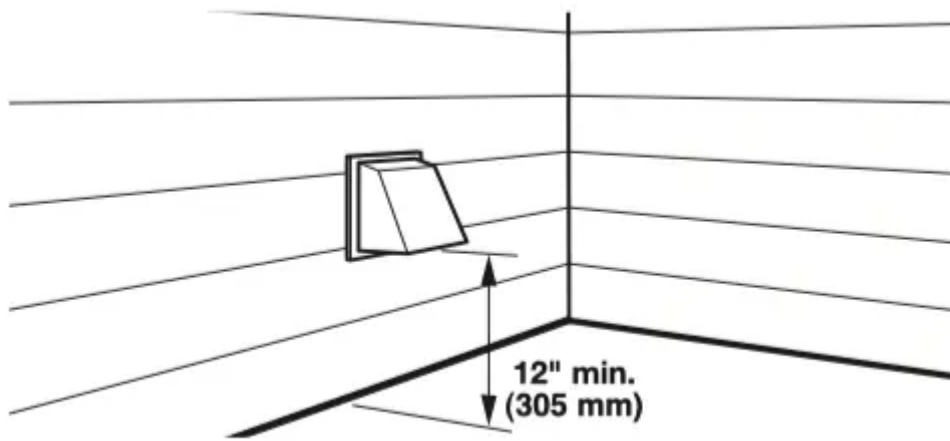

Vent System Length

Maximum Vent Length/Vent Connection

Maximum length of vent system depends upon the type of vent used, number of elbows, and type of exhaust hood.

Vent System Chart (Rigid Metal Vent)

No. of 90° Turns	Box and Louvered Hoods	Angled Hood
0	135 ft. (41.2 m)	129 ft. (39.3 m)
1	125 ft. (38.1 m)	119 ft. (36.3 m)
2	115 ft. (35.1 m)	109 ft. (33.2 m)
3	106 ft. (32.3 m)	100 ft. (30.5 m)
4	98 ft. (29.9 m)	92 ft. (28.0 m)

For vent systems not covered by the vent specification chart, see your parts distributor.

Provision must be made for enough air for combustion and ventilation. (Check governing codes and ordinances.) See the “Recessed Area and Closet Installation Instructions” in the “Stacked Washer/Gas Dryer Location” and “Stacked Washer/ Electric Dryer Location” sections.

A 4" (102 mm) outlet hood is preferred. However, a 2 1/2 " (64 mm) outlet exhaust hood may be used. A 2 1/2 " (64 mm) outlet creates greater back pressure than other hood types.

For permanent installation, a stationary vent system is required.

Connect Vent

1. If connecting to existing vent, make sure the vent is clean.
2. Using a 4" (102 mm) clamp, connect vent to exhaust outlet in dryer.

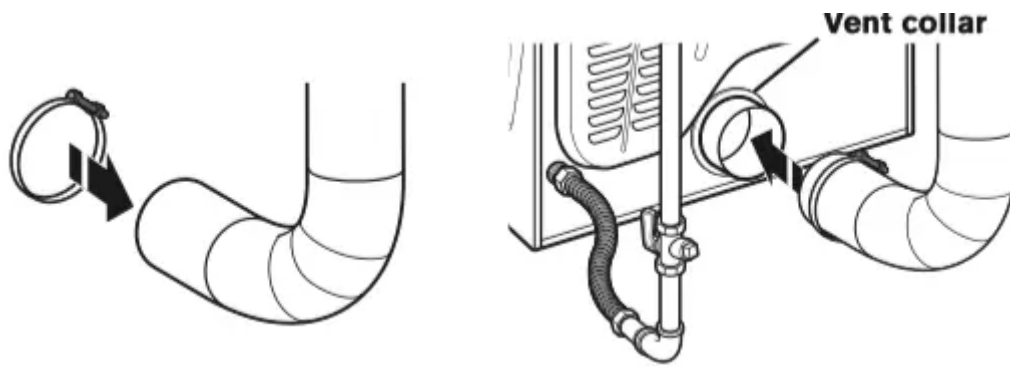

NOTE: Do not remove vent collar.

3. Tighten hose clamp with Phillips screwdriver.

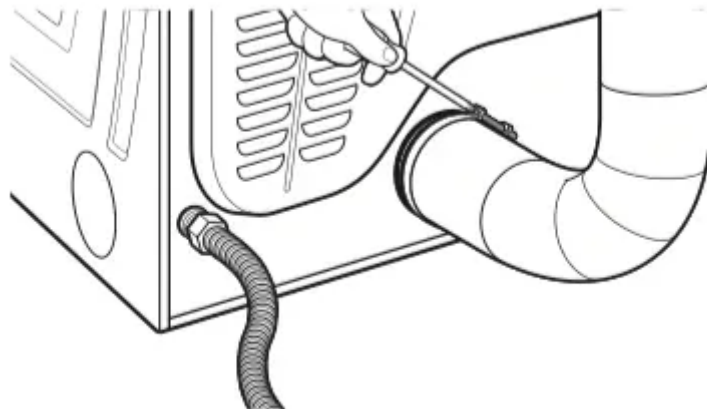

4. Make sure the vent is secured to exhaust hood with a 4" (102 mm) clamp.

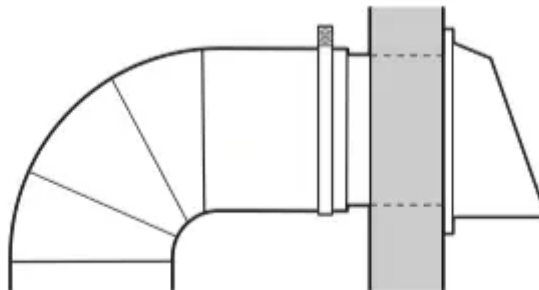

5. Move dryer into final position. Do not crush or kink vent. Make sure dryer is level.

If an Exhaust Hood Cannot be Used

The outside end of main vent should have a sweep elbow directed downward.

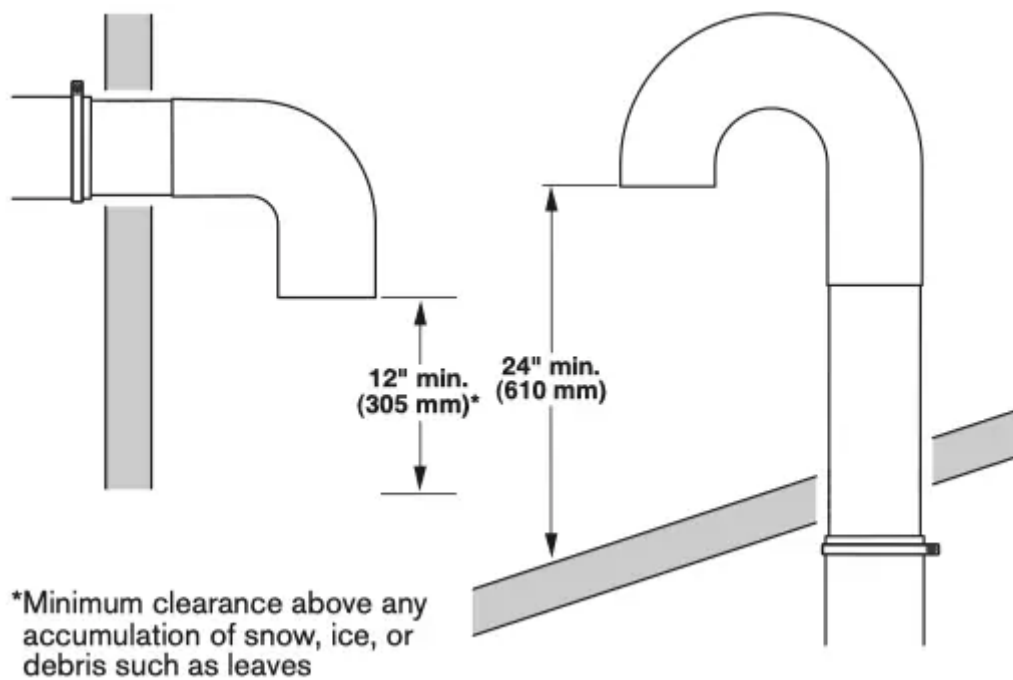

If main vent travels vertically through the roof, rather than through wall, install a 180° sweep elbow on end of vent at least 2 ft. (610 mm) above surface of roof.

The opening in wall or roof shall have a diameter 1/2" (13 mm) larger than vent diameter. Vent should be centered in opening.

Do not install screening over end of vent for best performance.

Multiple Dryer Venting

A main vent can be used for venting a group of dryers. The main vent should be sized to remove 200 CFM of air per dryer. Large capacity lint screens of proper design may be used in main vent if checked and cleaned frequently. The room where the dryers are located should have make-up air equal to or greater than CFM of all the dryers in the room.

Back-draft Damper Kit, Part No. 3391910, is available from your distributor and should be installed in the vent of each dryer to keep exhausted air from returning into dryers and to keep exhaust in balance within main vent. Unobstructed return air openings are required.

Each vent should enter the main vent at an angle pointing in the direction of the airflow. Vents entering from the opposite side should be staggered to reduce the exhausted air from interfering with the other vents.

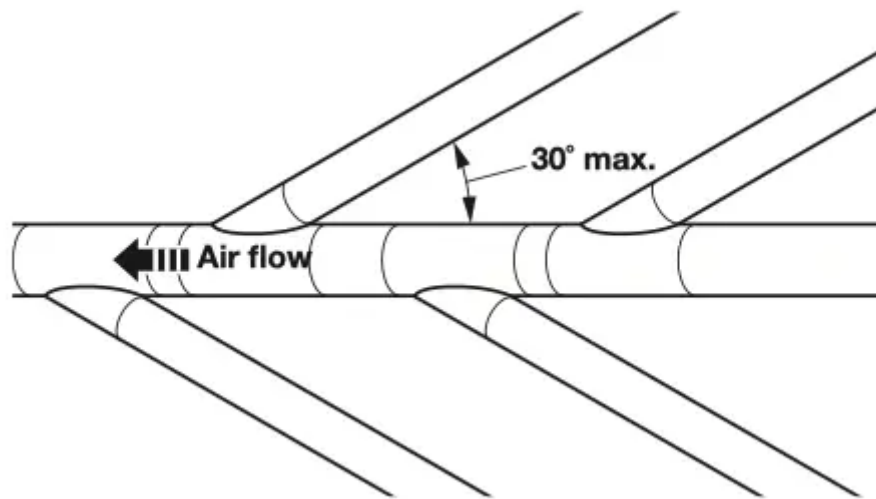

The maximum angle of each vent entering the main vent should be no more than 30°.

DRYER GAS SUPPLY REQUIREMENTS

Type of Gas

This dryer is equipped for use with natural gas. It is design-certified by CSA International for propane and butane gases with appropriate conversion. No attempt shall be made to convert dryer from gas specified on serial/rating plate for use with a different gas without consulting the serving gas supplier.

Conversion must be done by a qualified service technician.

Gas conversion kit part numbers are listed on gas valve burner base.

Gas Supply Line

Recommended Method

Provide a gas supply line of 1/2" (13 mm) rigid (IPS) pipe to dryer location. Pipe joint compounds that resist action of propane gas must be used. Do not use TEFLON[®]† tape. With propage gas, piping or tubing size can be 1/2" (13 mm) minimum. Usually, propane gas suppliers determine size and materials used in the system.

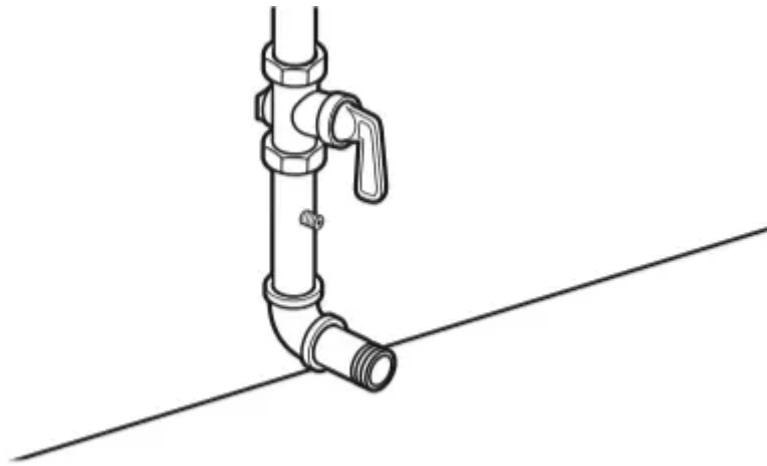

Gas Supply Pressure Testing

A 1/8" (3 mm) NPT minimum plugged tapping, accessible for gauge testing, must be installed immediately downstream of the installed shut-off valve to the dryer (as shown above). The dryer must be disconnected from the gas supply piping system during any pressure testing of the system at test pressures in excess of 1/2" psig (352 kg/m²).

Alternate Method

The gas supply may also be connected using 3/8" (10 mm) approved copper or aluminum tubing. If the total length of the supply line is more than 20 ft. (6.1 m), larger tubing will be required.

If using natural gas, do not use copper tubing. Pipe joint compounds that resist action of type of gas supplied must be used.

Shut-off valve required

The supply line must be equipped with a manual shut-off valve installed within 6 ft. (1.8 m) of dryer in accordance with National Fuel Gas Code, ANSI Z223.1. This valve should be located in same room as dryer. It should be in a location that allows ease of opening and closing. Do not block access to shut-off valve. In Canada, an individual manual shut-off valve must be installed in accordance with the B149 installation codes CAN/CGA B149.1 and CAN/CGA B149.2.

Flexible Metal Appliance Connector

It is recommended that a new flexible stainless steel gas line, design-certified by CSA International, be used for connecting the dryer to the gas supply line. (The gas pipe which extends through the lower rear of the dryer is provided with 3/8" (10 mm) male pipe thread.)

NOTE: Do not kink or damage the flexible stainless steel gas line when moving the door.

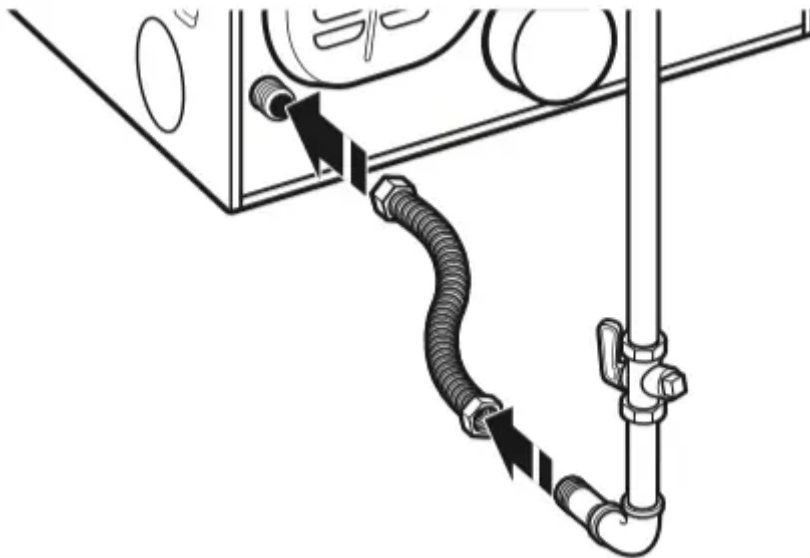

Rigid Pipe Connection

The rigid pipe connection requires a combination of pipe fittings to obtain an in-line connection to dryer.

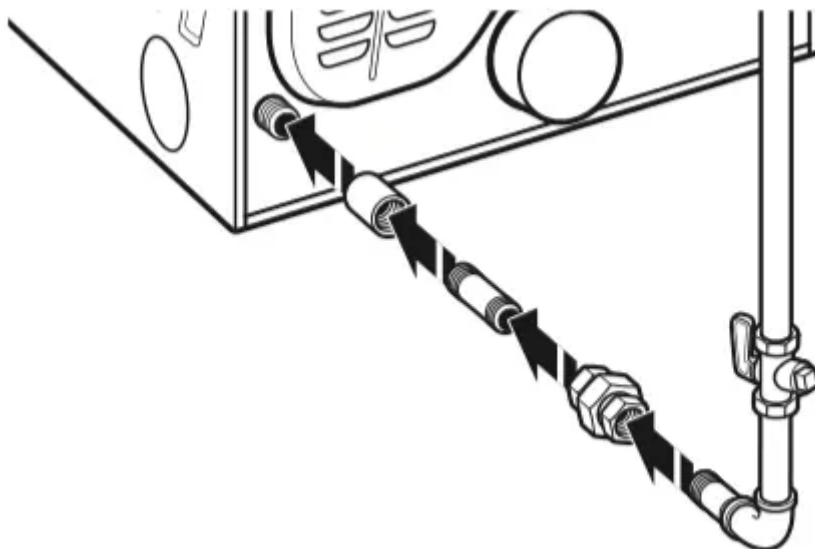

INSTALLING STACKED WASHER/DRYER

Remove Transport System

NOTE: Slide washer/dryer onto cardboard or hardboard before moving to avoid damaging floor covering.

! WARNING

Excessive Weight Hazard

Use two or more people to move and install washer/dryer.

Failure to do so can result in back or other injury.

IMPORTANT: Position the washer/dryer so that the rear of the washer is within approximately 3 ft. (900 mm) of its final location. There are four shipping bolts in the rear panel of the washer that support the suspension system during transportation. These bolts also retain the power cord inside the washer until the bolts are removed.

1. Keep the washer/dryer in the upright position while removing the shipping bolts.
2. Using a 1/2" (13 mm) wrench, loosen each of the bolts.

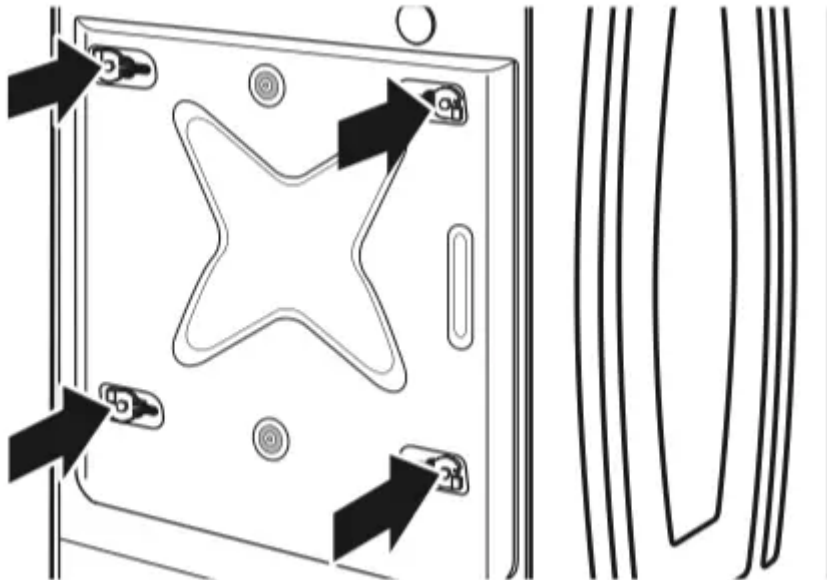

3. Once the bolt is loose, move it to the center of the hole and completely pull out the bolt, including the plastic spacer covering the bolt. Once all four bolts are removed, discard the bolts and spacers.

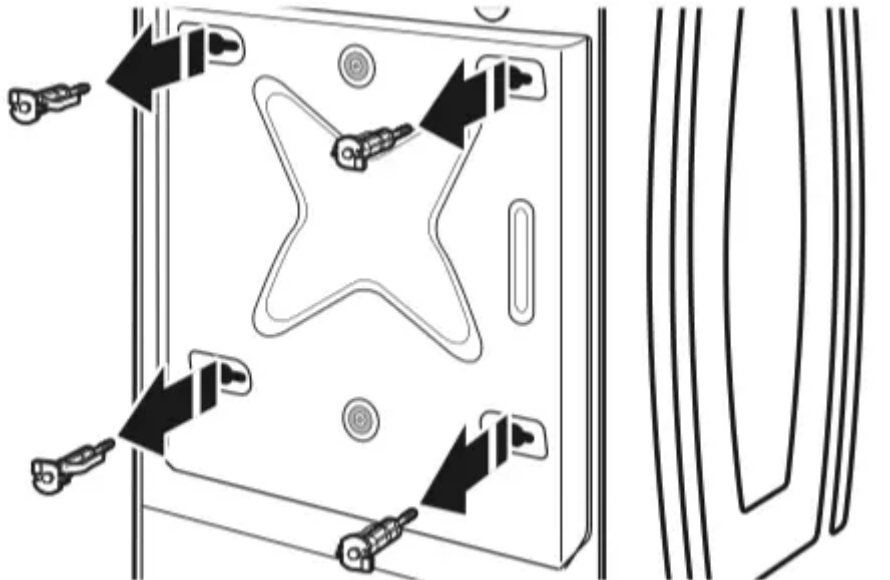

4. Models with separate washer power cords: Push the power cord plug into the opening on the right side of the rear panel and pull the power cord through the opening on the left side of the rear panel and close holes with the attached cap. Do not pull plug end of power cord through the right side hole.

NOTE: To avoid damage to internal washer parts or the power cord, if the cord does not pull out of the washer rear panel easily, do not force it. Remove the washer rear panel and guide the power cord around the obstruction and out the hole on the left side of the rear panel.

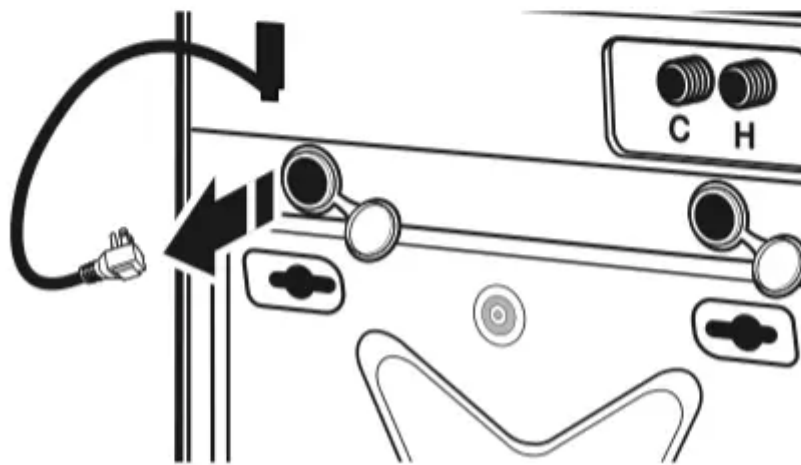
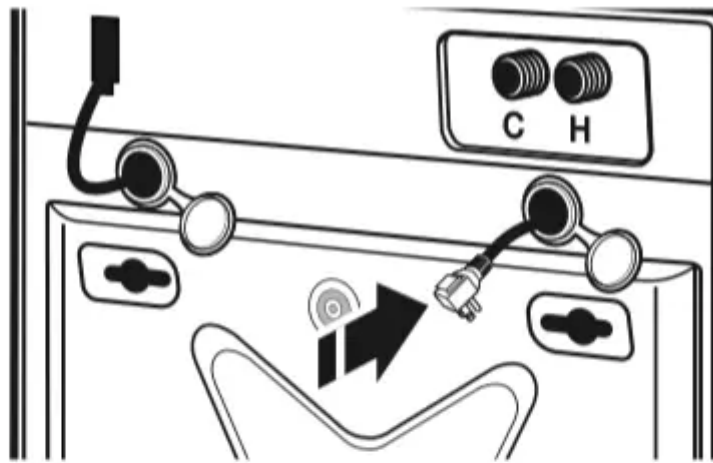

5. Close the bolt holes with the four transport bolt hole plugs.

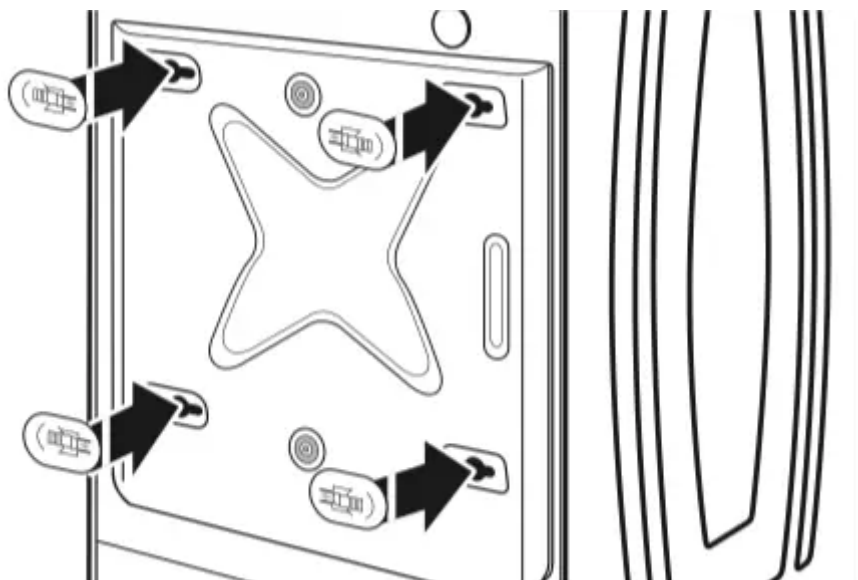

IMPORTANT: If the washer/dryer is to be transported, call your product distributor or installer. To avoid suspension and structural damage, your washer/dryer must be properly set up for relocation by a trained professional.

Connect Inlet Hoses

Insert new hose washers (supplied) into each end of the inlet hoses. Firmly seat the washers in the couplings.

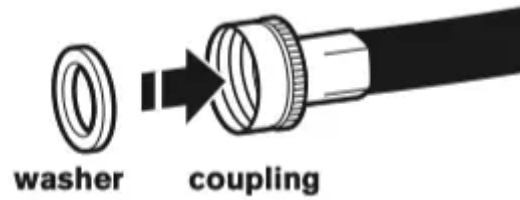

Connect Inlet Hoses to Water Faucets

Make sure the washer drum is empty.

1. Attach a hose to the hot water faucet. Screw on coupling by hand until it is seated on the washer.

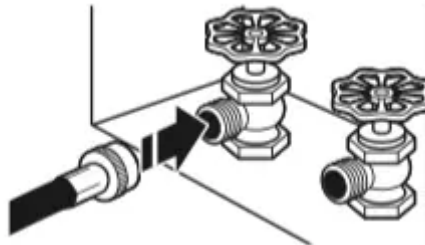

2. Attach a hose to the cold water faucet. Screw on coupling by hand until it is seated on the washer.

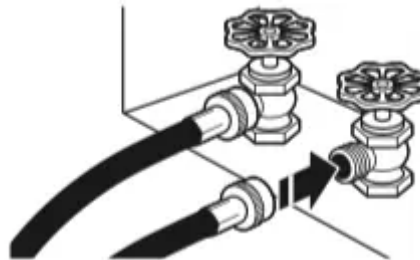

3. Using pliers, tighten the couplings with an additional two-thirds turn.

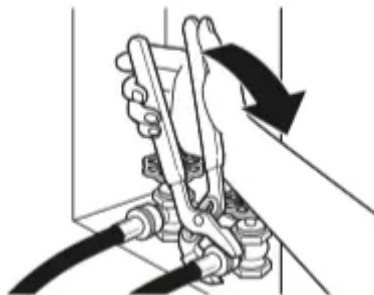

NOTE: Do not overtighten or use tape or sealants on the valve. Damage to the valves can result.

Clear Water Lines

- Run water through both faucets and inlet hoses, into a laundry tub, drainpipe, or bucket, to get rid of particles in the water lines that might clog the inlet valve screens.
- Check the temperature of the water to make sure that the hot water hose is connected to the hot water faucet and that the cold water hose is connected to the cold water faucet.



Connect Inlet Hoses to Washer

1. Attach the cold water hose to the washer's cold water inlet valve. Screw on coupling by hand until it is seated on the washer.

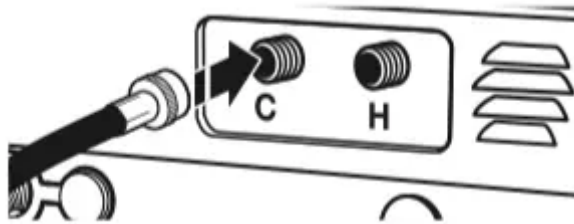

2. Attach the hot water hose to the washer's hot water inlet valve. Screw on coupling by hand until it is seated on the washer.

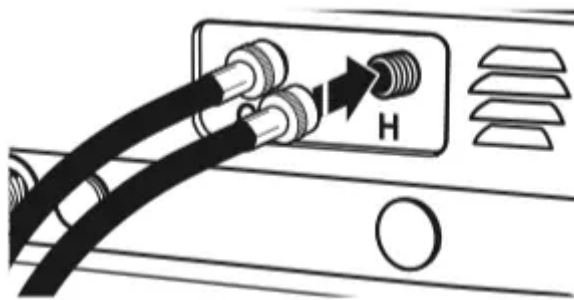

3. Using pliers, tighten the couplings with an additional two-thirds turn.

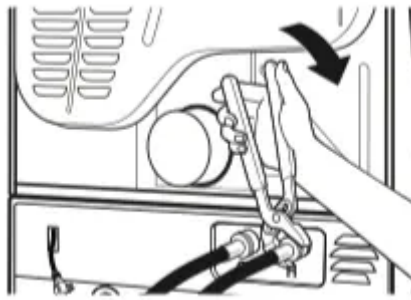

NOTE: Do not overtighten. Damage to the valve can result.

4. Turn on the water faucets completely and check for leaks.

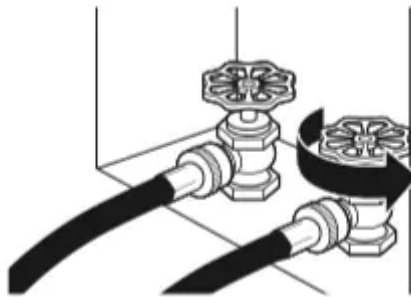

NOTE: Replace inlet hoses after 5 years of use to reduce the risk of hose failure. Record hose installation or replacement dates on the hoses for future reference. Periodically inspect and replace hoses if bulges, kinks, cuts, wear, or leaks are found.

Route Drain Hose

Proper routing of the drain hose avoids damage to your floor due to water leakage. Read and follow these instructions.

Remove drain hose from the washer drum

1. Using locking pliers, squeeze hose clamp tabs together and insert over the end of the drain hose.

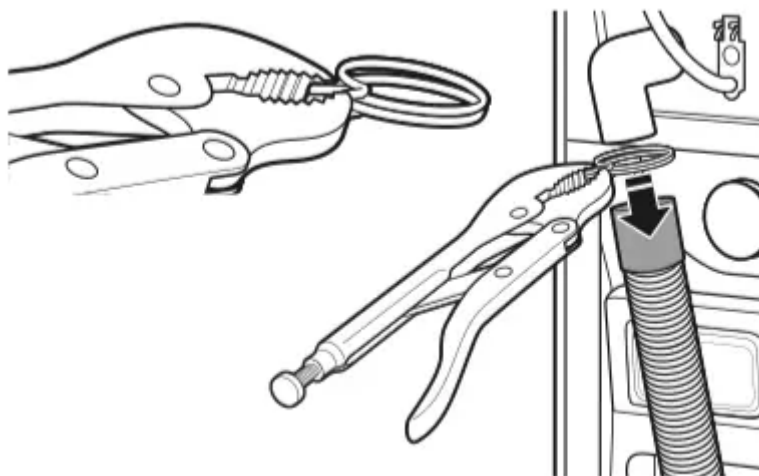

2. Slide the drain hose onto the washer connection.

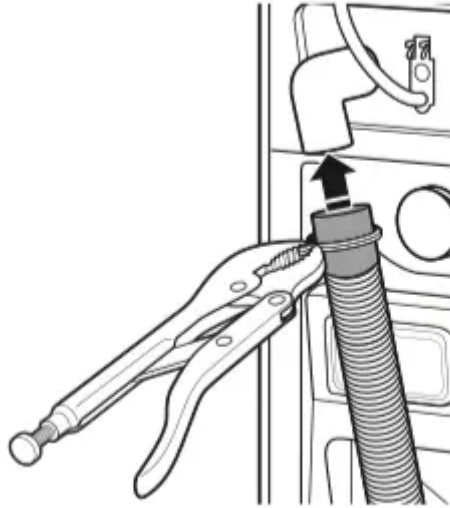

3. Once the drain hose is in place, release the pliers.

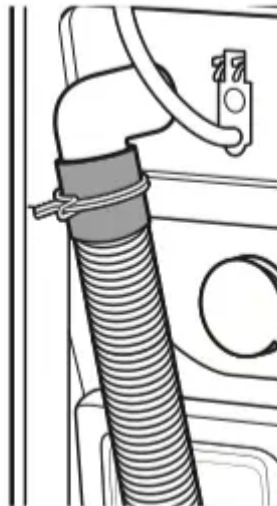

4. The washer drain system can be installed using a floor drain, wall standpipe, floor standpipe, or laundry tub.

Laundry tub drain or standpipe drain

Connect the drain hose form to the corrugated drain hose. Snap either end of the drain hose form to the drain hose at the point where the corrugation begins.

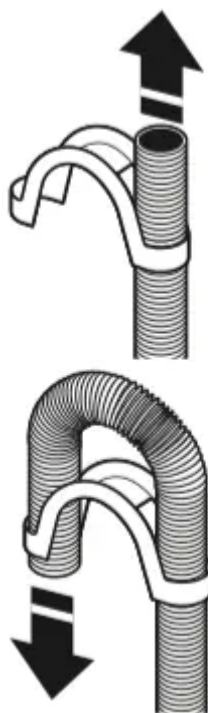

Bend drain hose over drain hose form and snap into place.

NOTE: Hose must not extend more than 1" (25 mm) past the end of the U bend.

To keep drain water from going back into the washer:

- Do not straighten the drain hose, do not force excess drain hose into standpipe. Hose should be secure, but loose enough to provide a gap for air.
- Do not lay excess hose on the bottom of the laundry tub.

Floor drain

You may need additional parts. See the "Alternate Parts" section.

Secure Drain Hose

1. Drape the power cord over the washer top.
2. Move the washer to its final location.
3. Place the drain hose in the laundry tub or standpipe, as shown.
4. Secure the drain hose using the supplied beaded tie strap



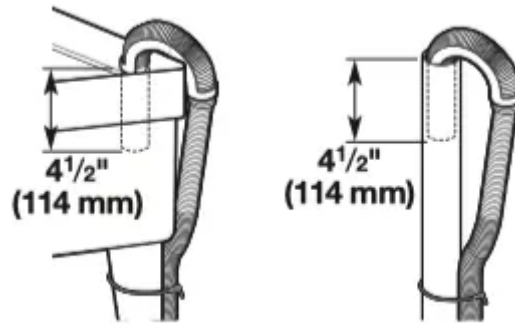

5. If the washer faucets and the drain standpipe are recessed, put the hooked end of the drain hose in the standpipe as shown.

NOTES:

- Do not force excess drain hose back into the rear of the washer.
- To avoid siphoning, do not seal the drain hose into the standpipe.

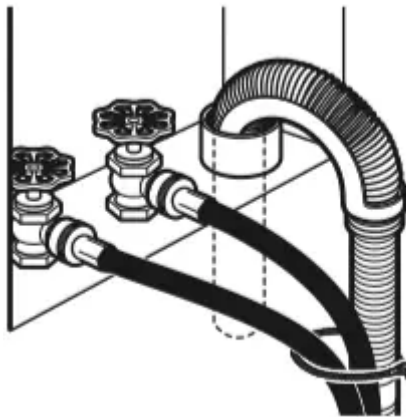

WASHER DRAIN SYSTEM

The washer can be installed using the standpipe drain system (floor or wall), the laundry tub drain system, or the floor drain system.

Standpipe drain system – wall or floor

The standpipe drain requires a minimum diameter standpipe of 2" (50 mm). The minimum carry-away capacity can be no less than 10 gal. (38 L) per minute.

Wall



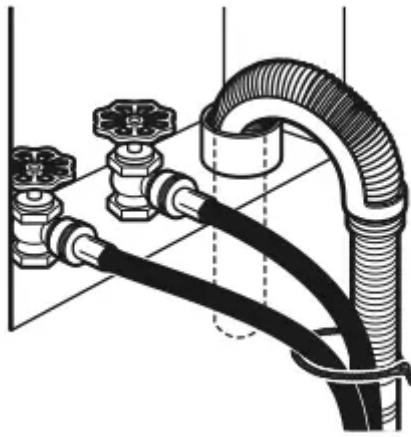

The top of the standpipe must be at least 30" (762 mm) high and no higher than 96" (2.4 m) from the bottom of the washer.

Floor

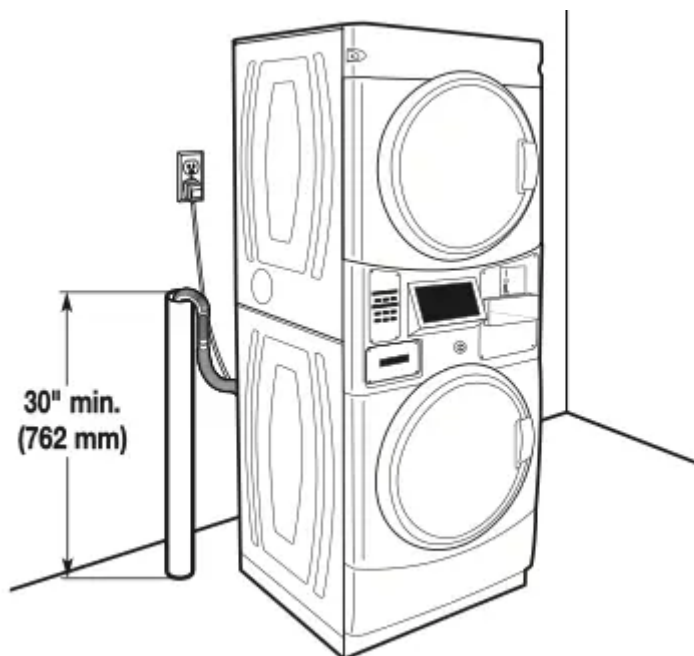

Laundry tub drain system

The laundry tub needs a minimum 20 gal. (76 L) capacity. The top of the laundry tub must be at least 30" (762 mm) above the floor.

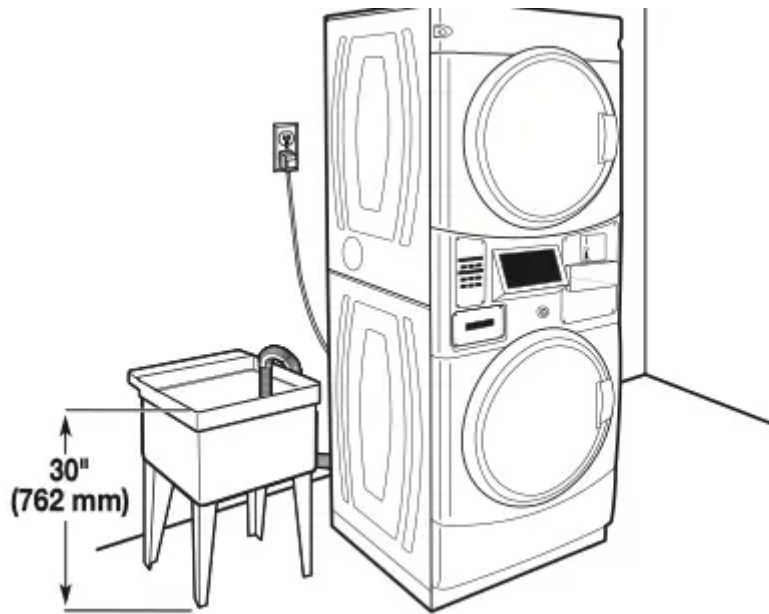

Floor drain system

The floor drain system requires a siphon break that may be purchased separately.

The siphon break (Part Number 285834) must be a minimum of 28" (710 mm) from the bottom of the washer. Additional hoses might be needed.

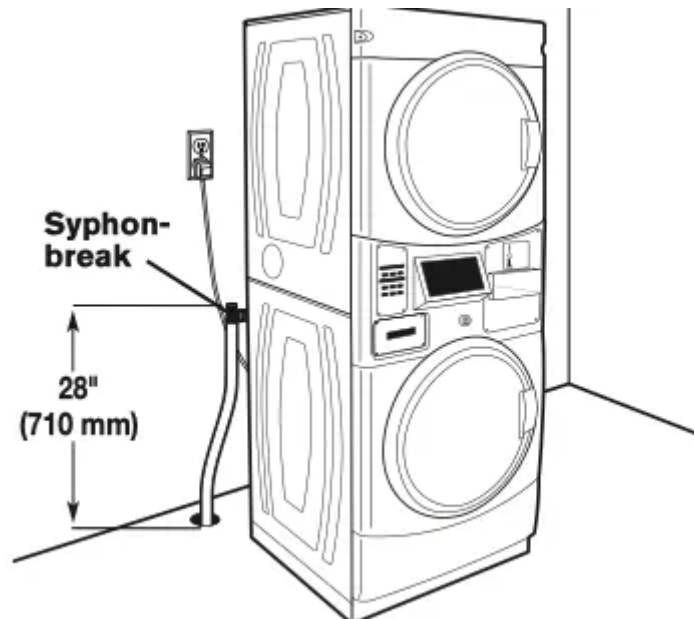

ELECTRIC DRYER ELECTRICAL CONNECTIONS

Strain Relief

Remove Terminal Block Cover

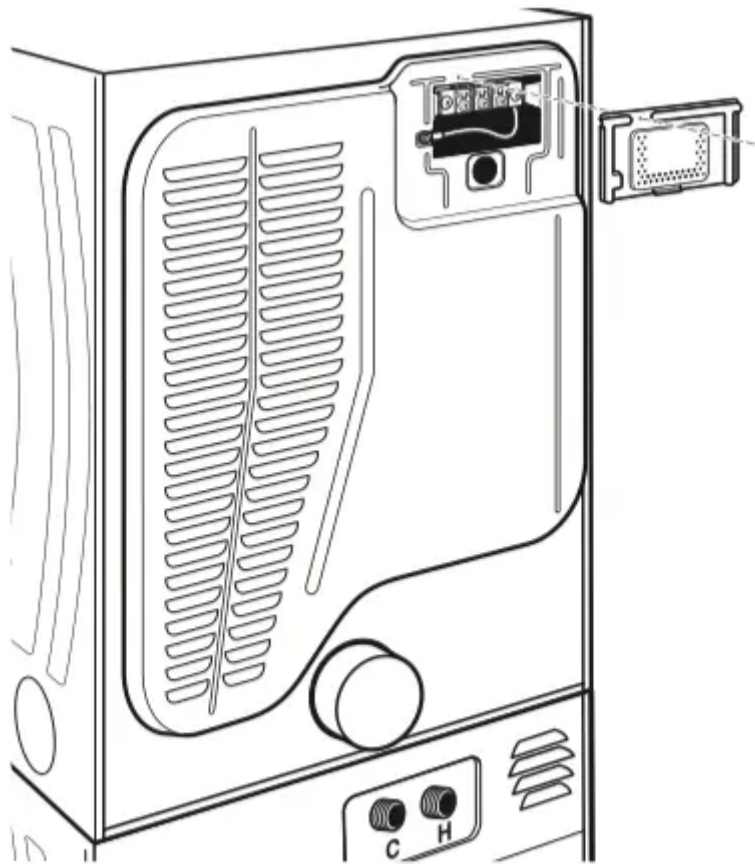

Power Supply Cord Strain Relief

1. Insert strain relief.

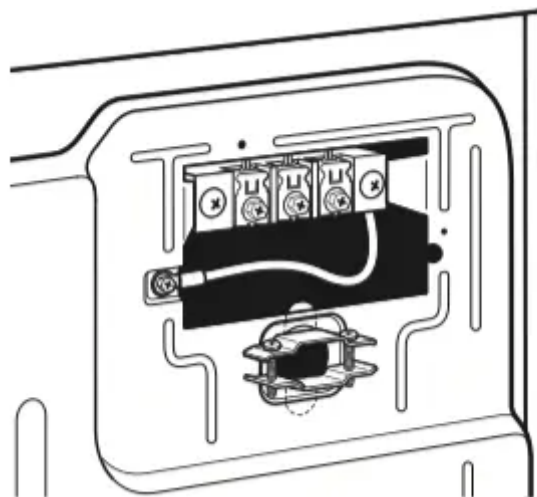

2. Insert power cord into strain relief.

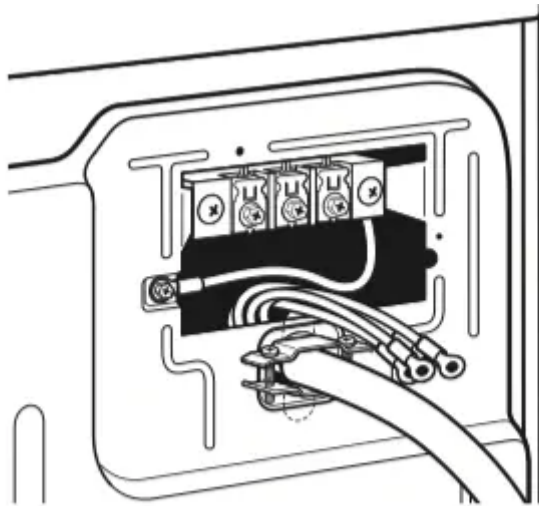

Strain Relief (Direct Wire)

Direct Wire Strain Relief

1. Insert strain relief.

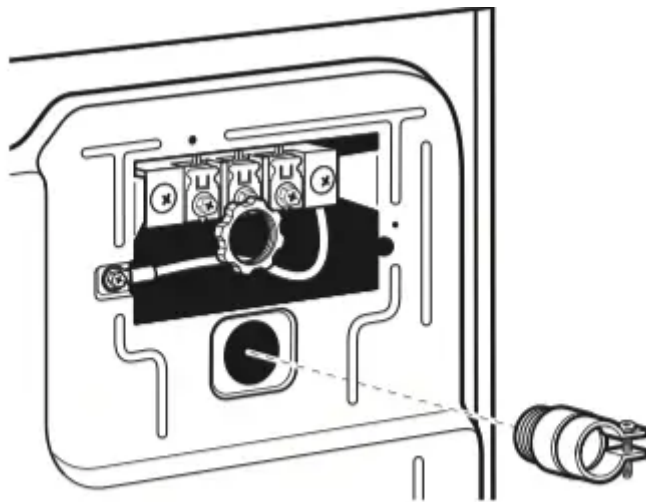

2. Insert conduit into strain relief and tighten clamp.

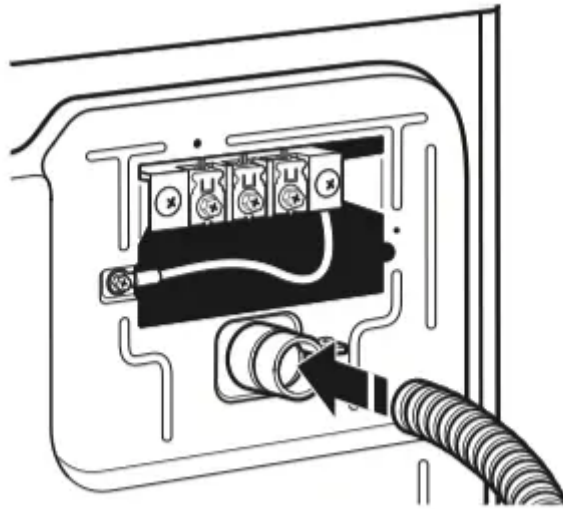

Connection Options

Power Cord

4-wire receptacle (NEMA Type 14-30R)



3-wire receptacle (NEMA Type 10-30R)



Direct Wire

4-wire direct

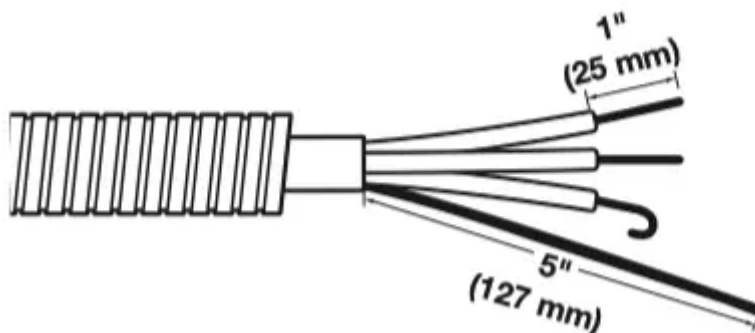

3-wire direct

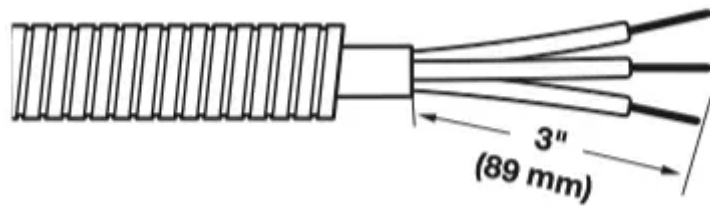

Connecting 4-Wire Connection: Power Supply Cord

IMPORTANT: A 4-wire connection is required for mobile homes and where local codes do not permit the use of 3-wire connections.

Standard Power Supply Cord Connectors



Flanged spade connector



Ring Connector

Connecting Ground and Neutral Wires

1. Remove center terminal block screw and the ground wire by removing the external ground connector screw.

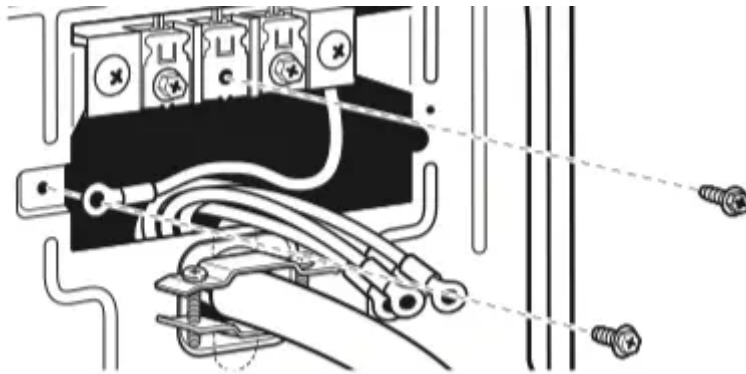

2. Connect ground and neutral wire to center terminal block.

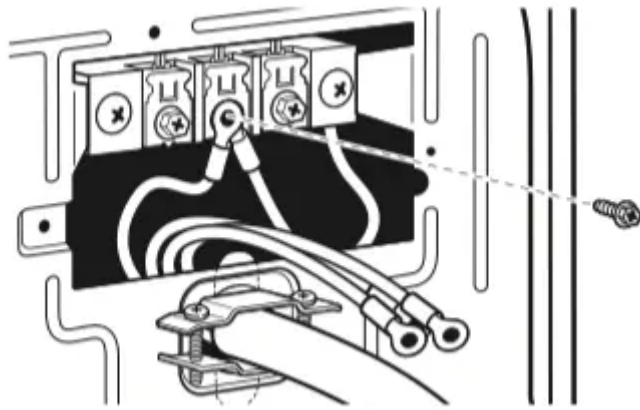

Connecting Direct Wire Ground

3. Connect ground wire (green or bare) with external ground connector screw.

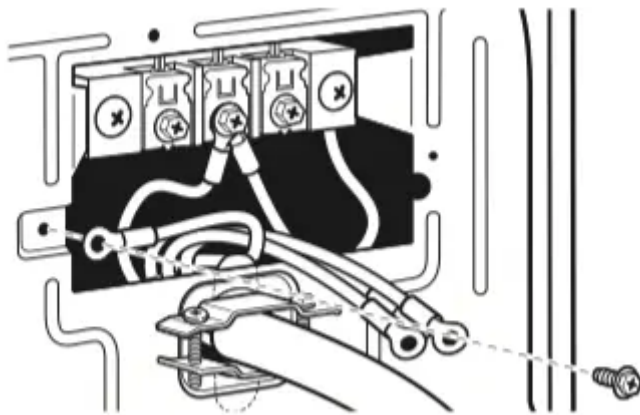

Connecting Remaining Wires

4. Connect remaining wires with outer terminal block screws.

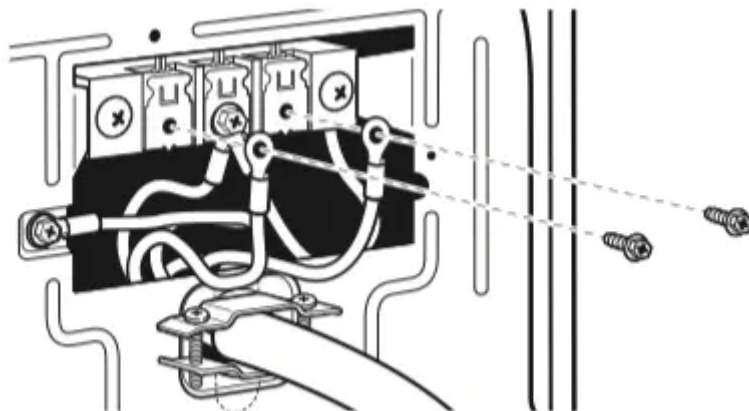

Connecting 3-Wire Connection: Power Supply Cord

Standard Power Cord Connectors



Flanged spade connector



Ring Connector

Connecting Neutral Wire

1. Loosen or remove center terminal block screw.

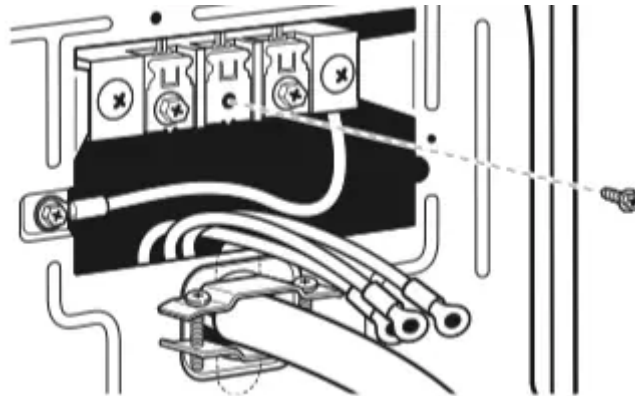

2. Connect neutral wire to center terminal block.

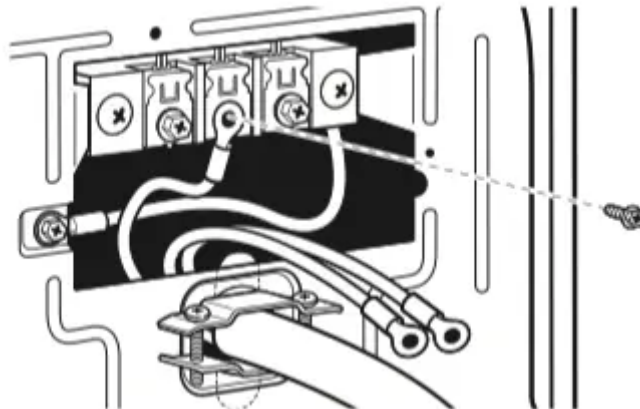

3. Connect remaining wires with outer terminal block screws.

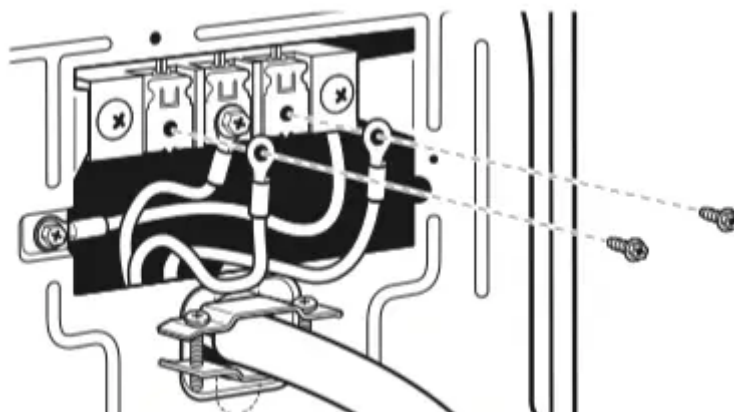

Connecting 4-Wire Connection: Direct Wire

IMPORTANT: A 4-wire connection is required for mobile homes and where local codes do not permit the use of 3-wire connections.

Direct wire cable must have 5 ft. (1.52 m) of extra length so dryer can be moved if needed.

Strip 5" (127 mm) of outer covering from end of cable, leaving bare ground wire at 5" (127 mm). Cut 1 1/2" (38 mm) from three remaining wires. Strip insulation back 1" (25 mm). Shape ends of wires into a hook shape.

Connecting Ground and Neutral Wires

1. Remove center terminal block screw and the ground wire by removing the external ground connector screw.

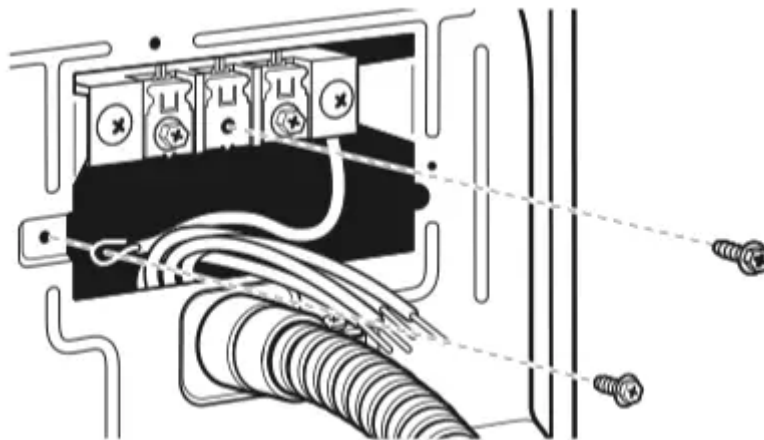

2. Connect ground and neutral wire to center terminal block.

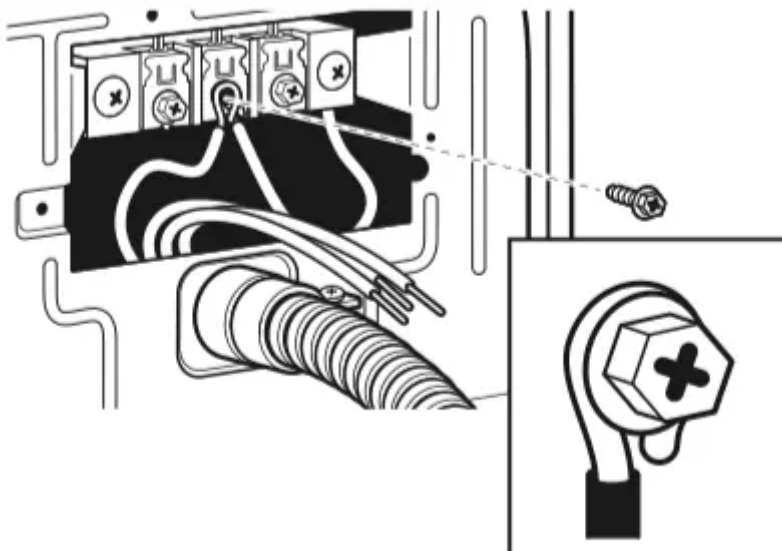

Connecting Direct Wire Ground

3. Connect ground wire (green or bare) with external ground connector screw.

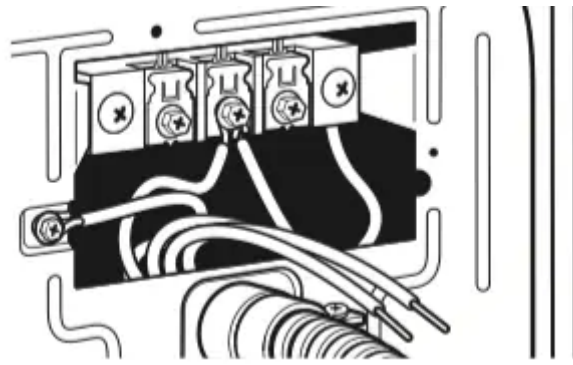

Connecting Remaining Wires

4. Connect remaining wires to outer terminal block.

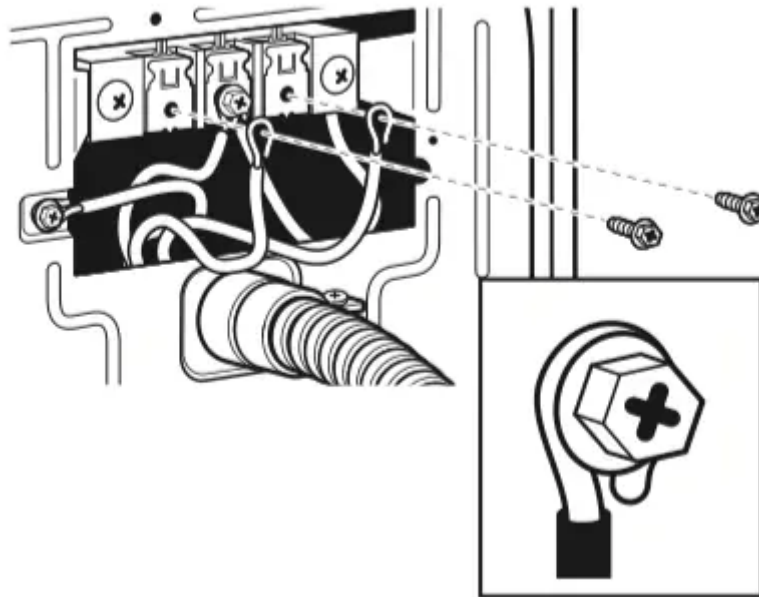

Connecting 3-Wire Connection: Direct Wire

Use where local codes permit connecting cabinet-ground conductor to neutral wire.

Direct wire cable must have 5 ft. (1.52 m) of extra length so dryer can be moved if needed.

Strip 3 1/2" (89 mm) of outer covering from end of cable. Strip insulation back 1" (25 mm). If using 3-wire cable with ground wire, cut bare wire even with outer covering. Shape ends of wires into a hook shape.

Connecting Neutral Wire

1. Loosen or remove center terminal block screw.

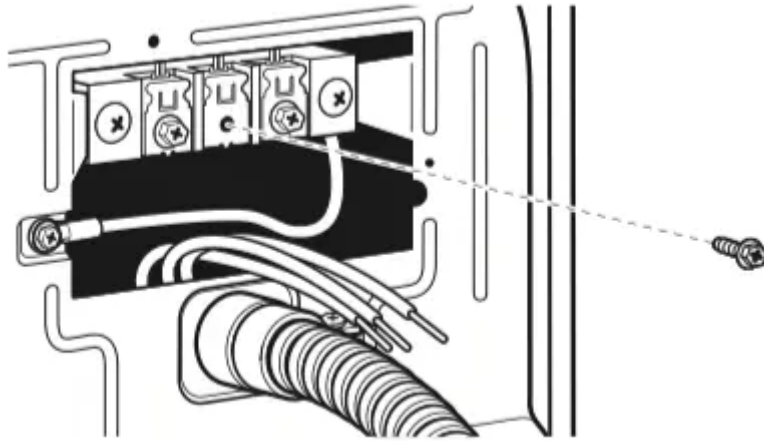

2. Connect neutral wire to center terminal block.

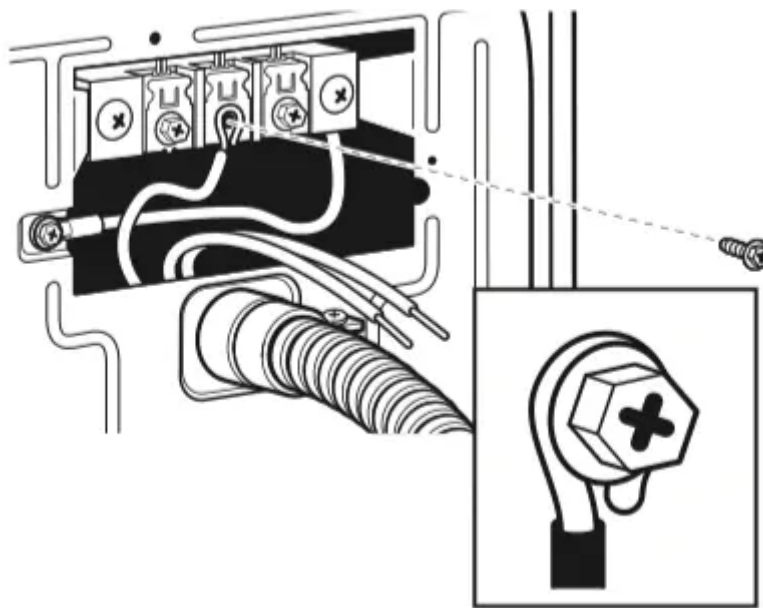

3. Connect remaining wires to outer terminal block.

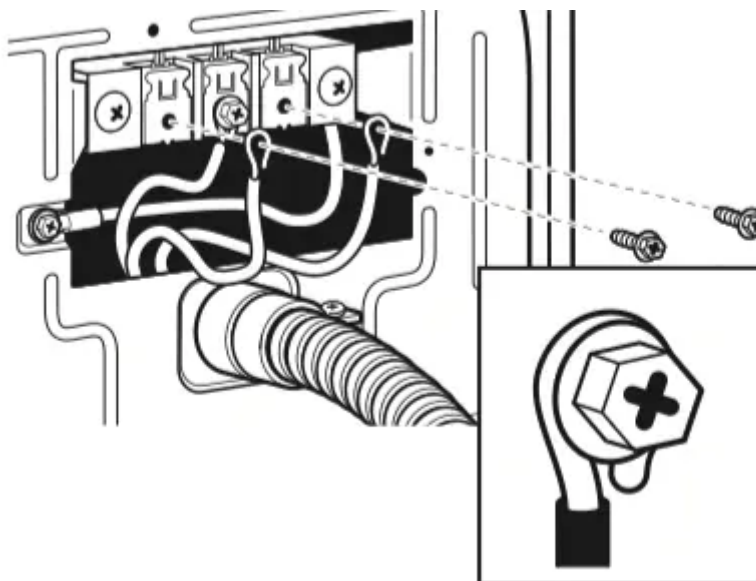

Connecting 3-Wire Connection: Optional

Use for direct wire or power supply cord where local codes do not permit connecting cabinet-ground conductor to neutral wire.

Connecting Neutral Wire

1. Remove center terminal block screw. Also remove neutral ground wire by removing external ground conductor screw.

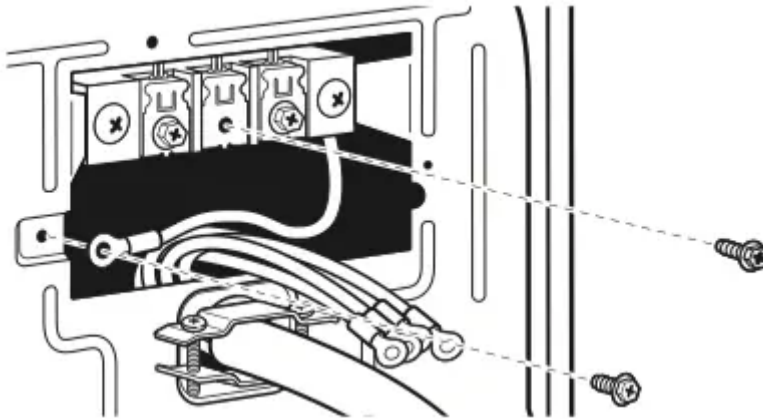

2. Connect neutral wire and neutral wire of power supply cord/ cable to center terminal block.

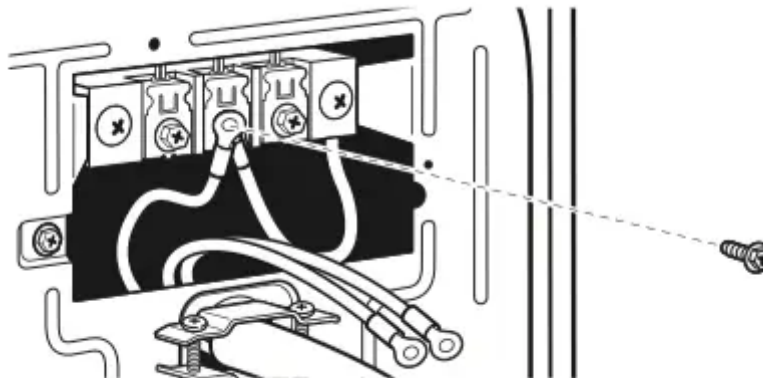

3. Connect remaining wires to outer terminal block.

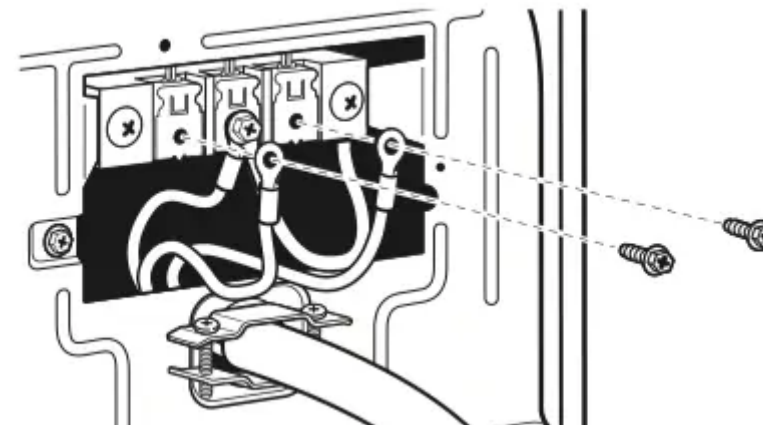

4. Connect a separate copper ground wire from the external ground conductor to an adequate ground.

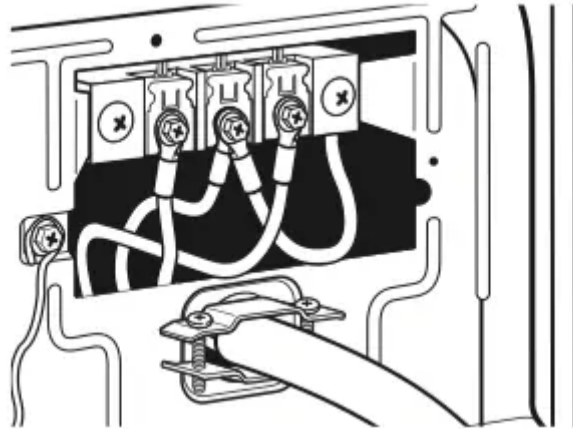

LEVELING

Leveling Stacked Washer/Dryer

Leveling your washer/dryer properly reduces excess noise and vibration.

1. Remove cardboard from beneath washer/dryer. Place a level on top edges of washer/dryer, checking each side and front. If not level, tip washer/dryer and adjust feet up or down as shown in Steps 3 and 4, repeating as necessary.

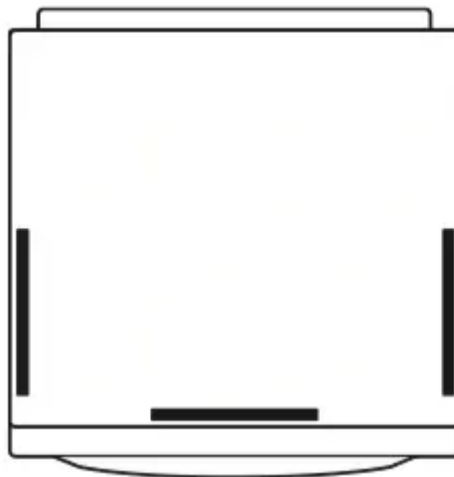

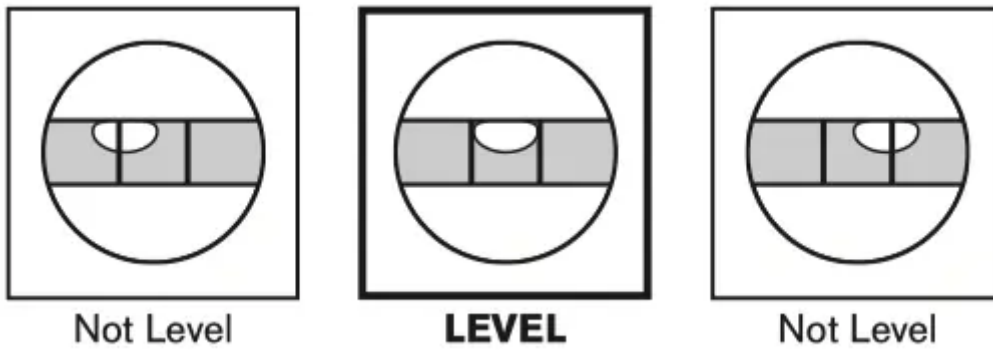

2. Grip washer/dryer from top and rock back and forth, making sure all four feet are firmly on floor. Repeat, rocking washer/dryer from side to side. If washer/dryer rocks, go to Step 3 and adjust leveling feet. If all four feet are in firm contact with floor, go to Step 4.



3. If washer/dryer is not level, use a 9/16" or 14 mm openend or adjustable wrench to turn jam nuts clockwise (as viewed from above) on feet until they are about 1/2" (13 mm) from the washer/ dryer cabinet. Then turn the leveling foot counterclockwise to lower the washer/ dryer or clockwise to raise the washer/dryer. Recheck levelness of washer/dryer and that all four feet are firmly in contact with the floor. Repeat as needed.

HELPFUL TIP: You may want to prop up front of washer/dryer about 4" (102 mm) with a wood block or similar object that will support weight of washer/dryer.

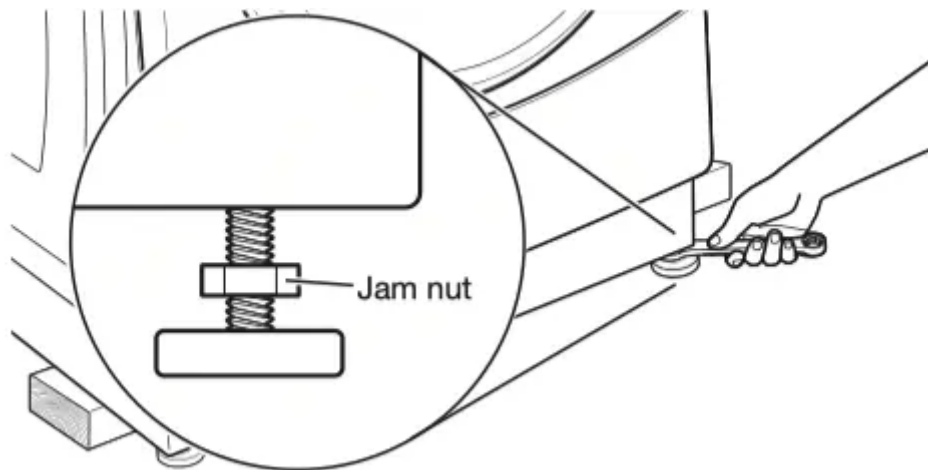

4. When washer/dryer is level and all four feet are firmly in contact with the floor, use a 9/16" or 14 mm open-end or adjustable wrench to turn jam nuts counterclockwise (as viewed from above) on leveling feet tightly against washer/dryer cabinet.

HELPFUL TIP: You may want to prop washer/dryer with wooden block.

Complete Installation

HELPFUL TIP: You may want to prop washer/dryer with wooden block.

1. Check the electrical requirements. Be sure that you have the correct electrical supply and the recommended grounding method. See the "Electrical Requirements" section.
2. Check that all parts are now installed. If there is an extra part, go back through the steps.
3. Check that you have all of your tools.
4. Dispose of/recycle all packaging materials.
5. Check that the water faucets are on.
6. Check for leaks around faucets and inlet hoses.

⚠ WARNING

Electrical Shock Hazard
Plug into a grounded 3 prong outlet.
Do not remove ground prong.
Do not use an adapter.
Do not use an extension cord.
Failure to follow these instructions can result in death, fire, or electrical shock.

7. Plug into a grounded outlet, or connect power.

8. To test and to clean your washer, measure 1/2 the detergent manufacturer's recommended amount of High Efficiency (HE) detergent for a medium-size load. Pour the detergent into the detergent dispenser. Select any cycle and allow the washer to complete one whole cycle.

9. Check dryer operation. Using a full heat cycle, let the dryer run for at least five minutes. Dryer will stop when time is used up.

NOTE: Dryer door must be closed for dryer to operate. When door is open, dryer stops, but timer continues to run. To restart dryer, close door and push cycle button.

If the burner does not ignite and you can feel no heat inside the dryer, shut off dryer for five minutes. Check that all supply valve controls are in "on" position and that the electrical cord is plugged in. Repeat five-minute test.

REVERSING DRYER DOOR SWING (OPTIONAL)

Remove the Door Assembly

1. Place a towel or soft cloth on top of dryer or work space to avoid scratching of the surface.
2. Remove three of the four screws that hold the door hinge on the front panel of the dryer. Partially loosen the remaining screw with keyhole opening and lift the door off the screw.

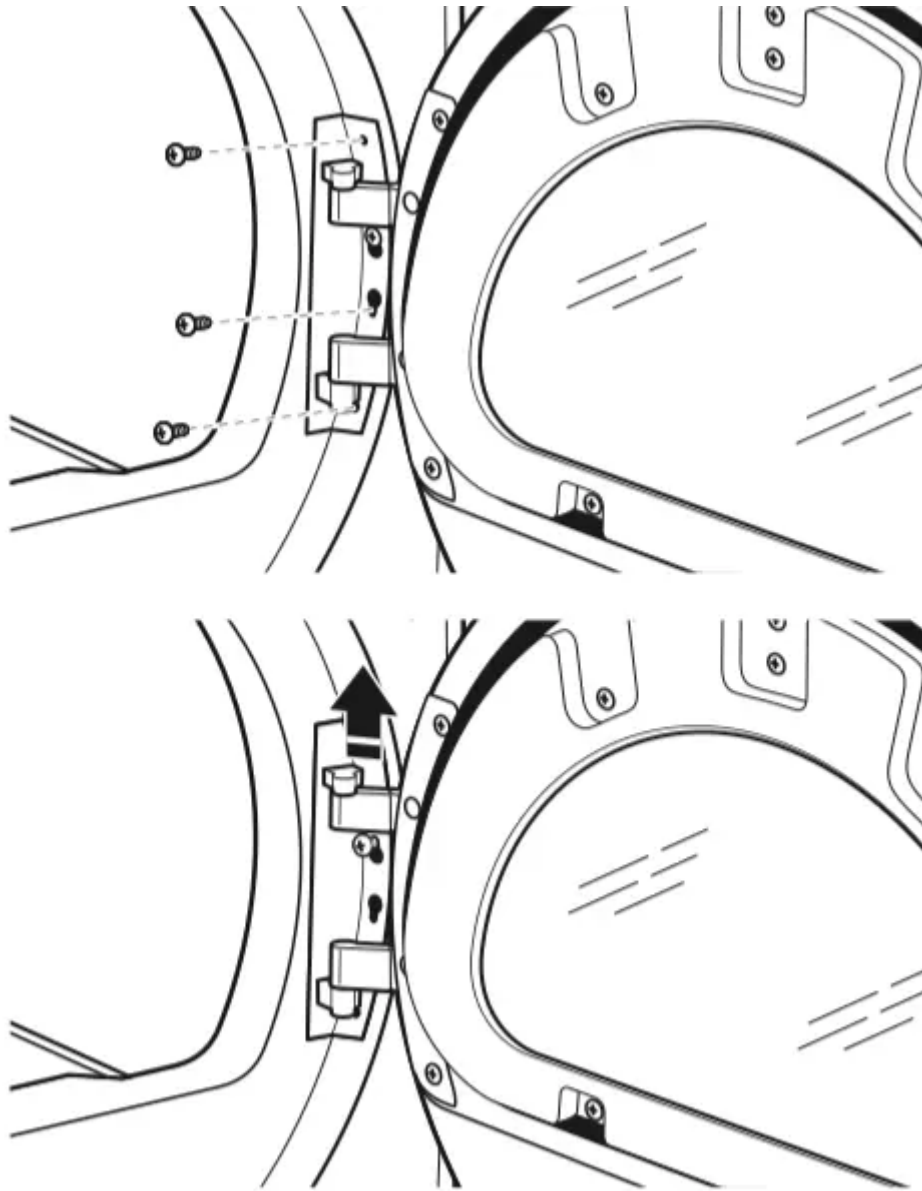

3. Lay the door assembly on a previously prepared flat surface with the inside (inner door assembly) facing up, and remove six phillips-head screws to release outer door assembly from inner door assembly.

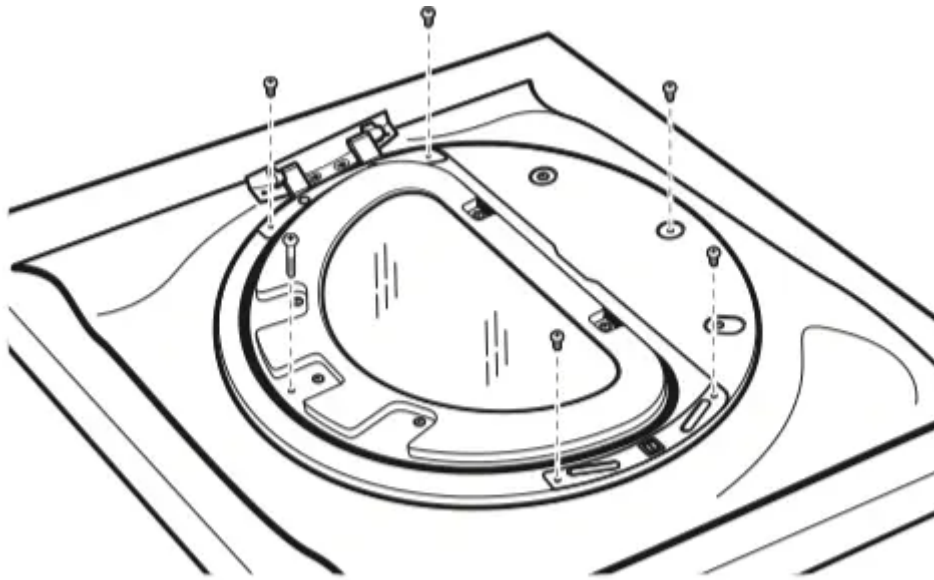

NOTE: It is important that you remove only the six indicated screws.

4. Lift the inner door assembly off outer door assembly.

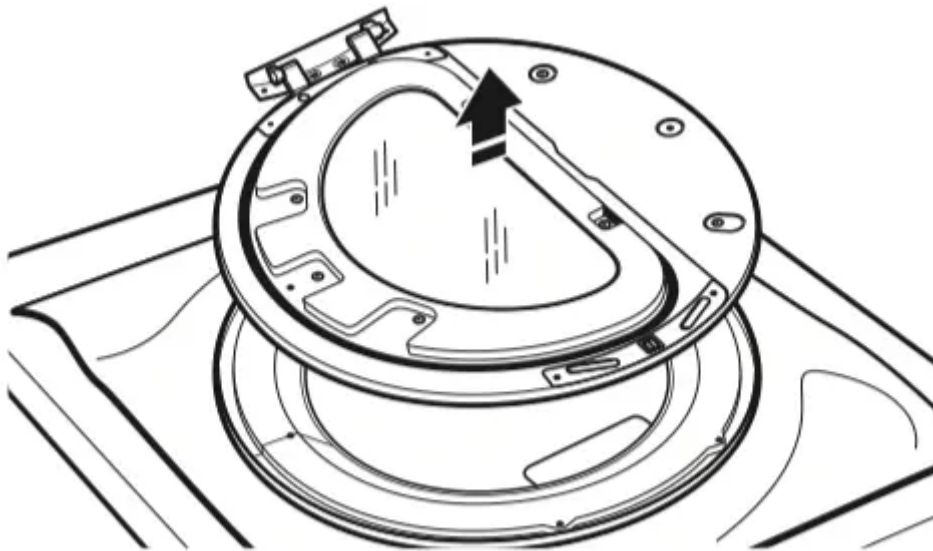

5. Remove four Phillips-head screws to release center insert from outer door ring.

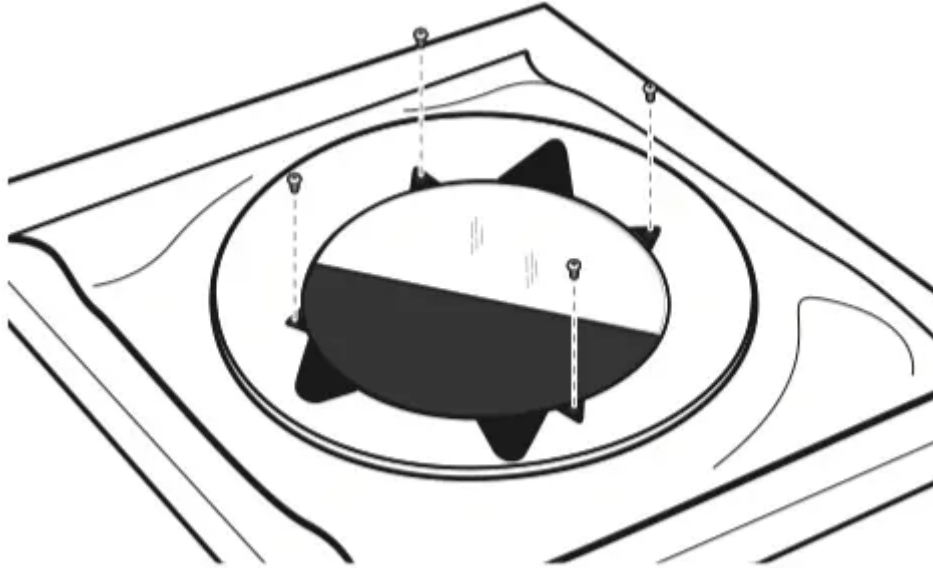

6. Lift and rotate center insert 180 degrees.

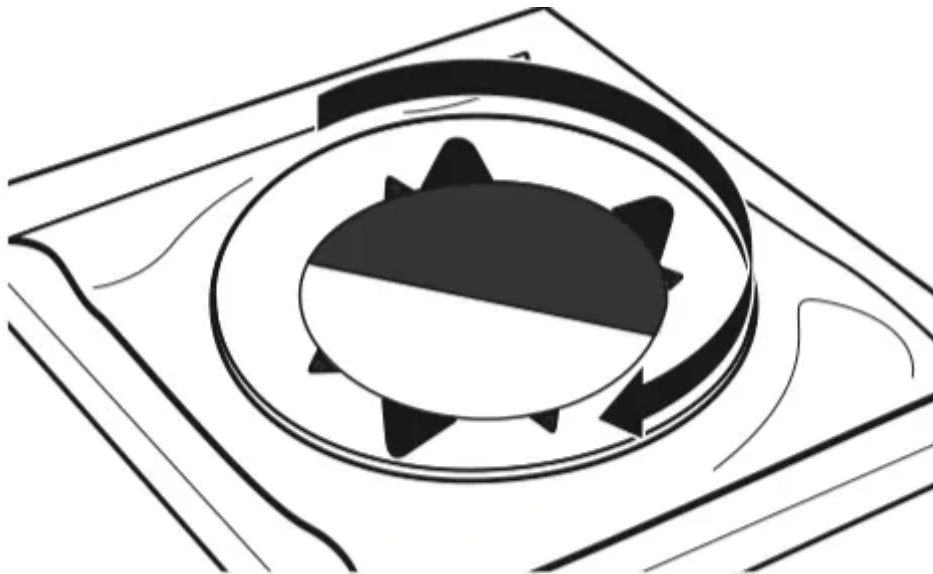

7. Reassemble the center insert and outer door ring with the four screws

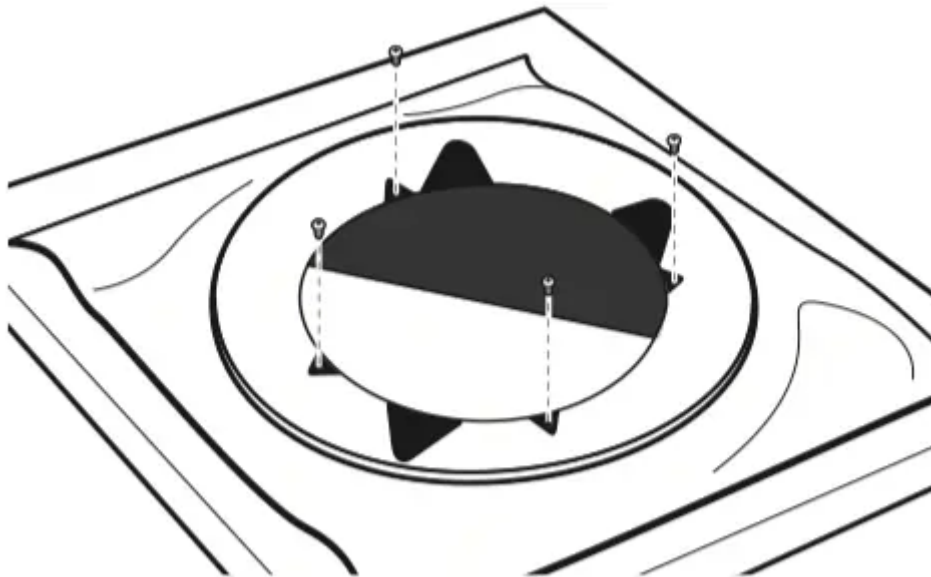

Reverse Hinge

1. Use a small flat-blade screwdriver to remove two plug strips from the inner door. Slide the head of the screwdriver under the plugs, without scratching inner door surface, and lift up strip.

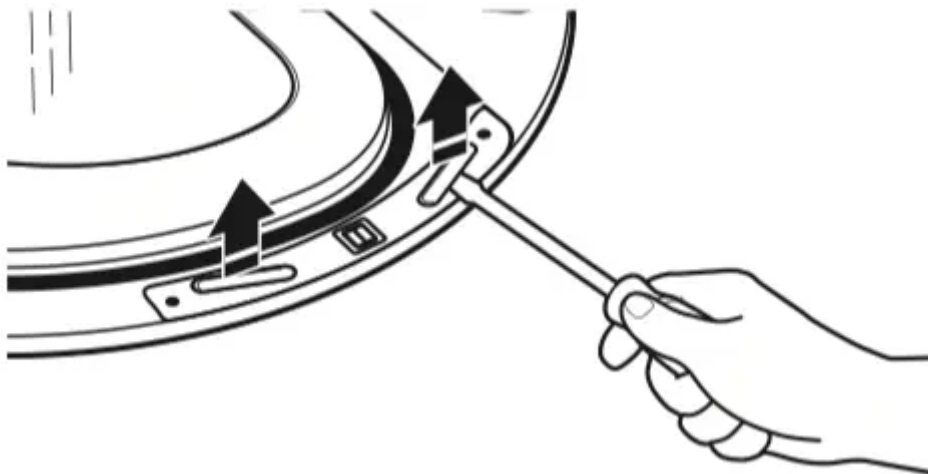

2. Remove the four screws that attach to inner door hinge.

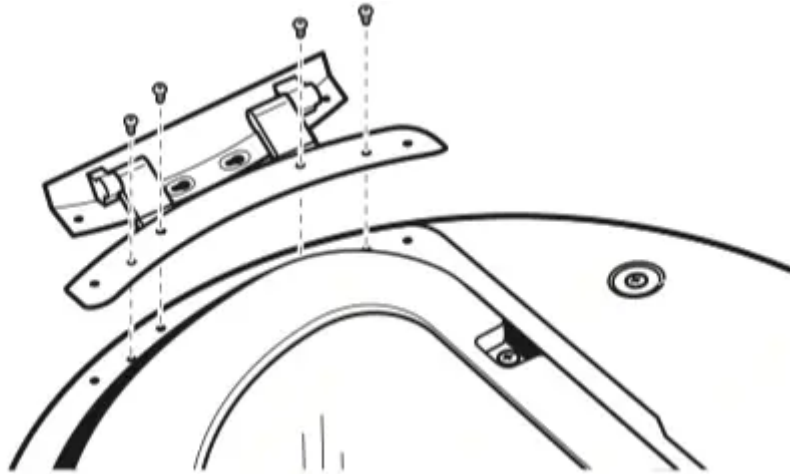

3. Move hinge to other side. Reinstall four screws.

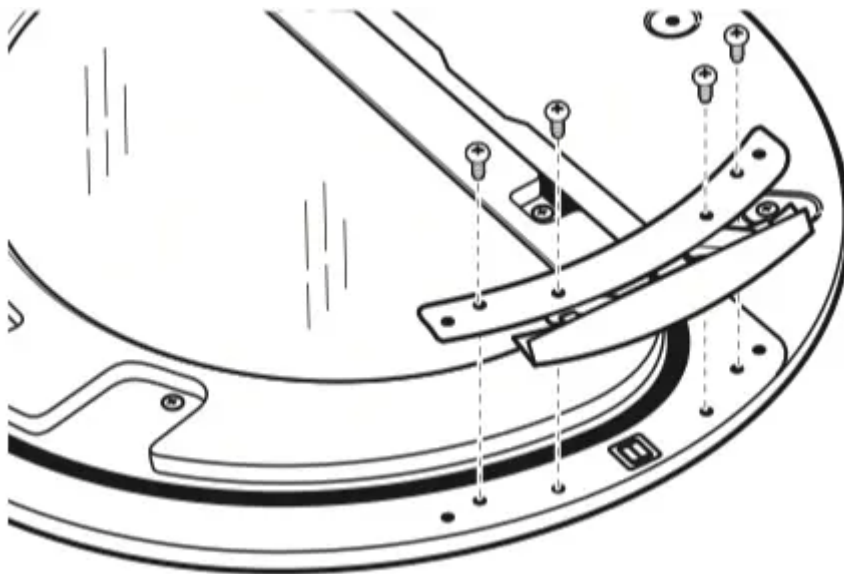

4. Reinstall plug strips on opposite side of the inner door.

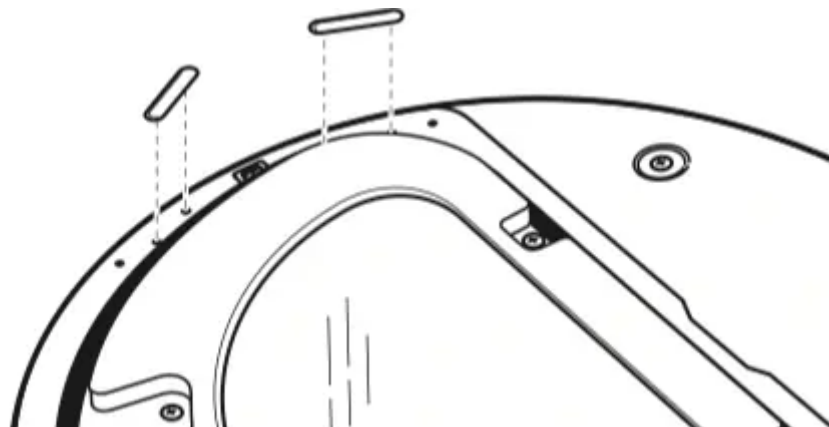

5. Check for fingerprints on the glass. Clean if necessary.

Replace the Door Assembly

1. Place the inner door assembly inside the outer door assembly.

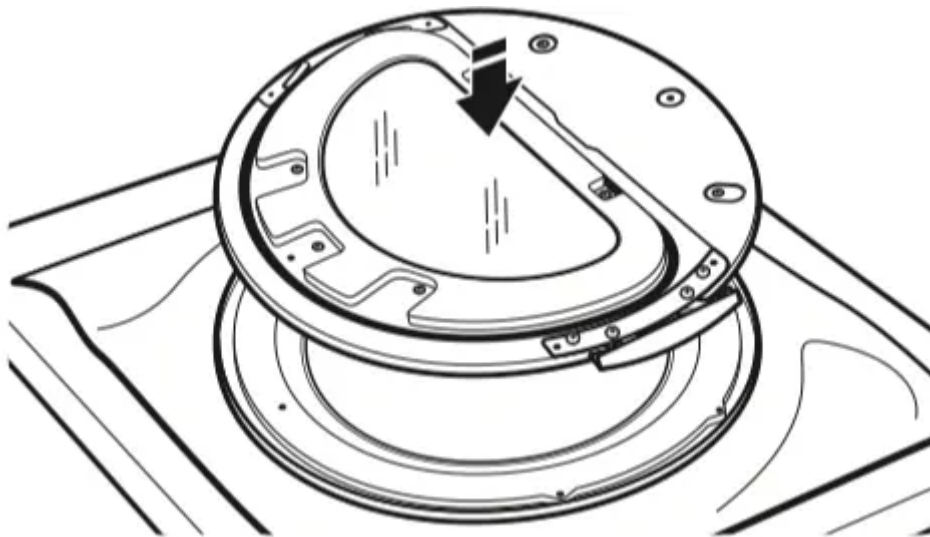

2. Reassemble the inner and outer door assemblies with the six screws.

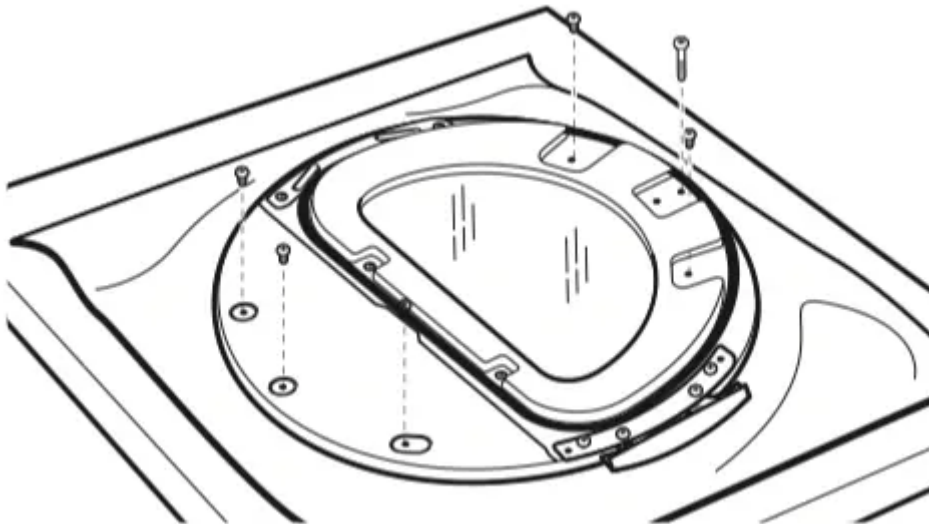

Reverse the strike

1. Use a small flat-blade screwdriver to remove plug strip from the dryer door opening. Slide the head of the screwdriver under the plugs, without scratching dryer surface, and lift up strip.

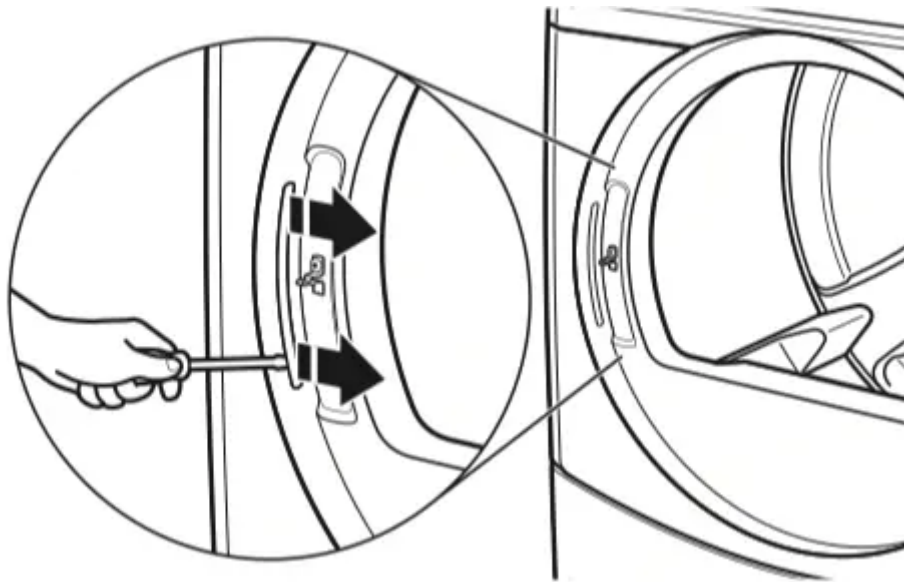

2. Remove the strike using a Phillips screwdriver.

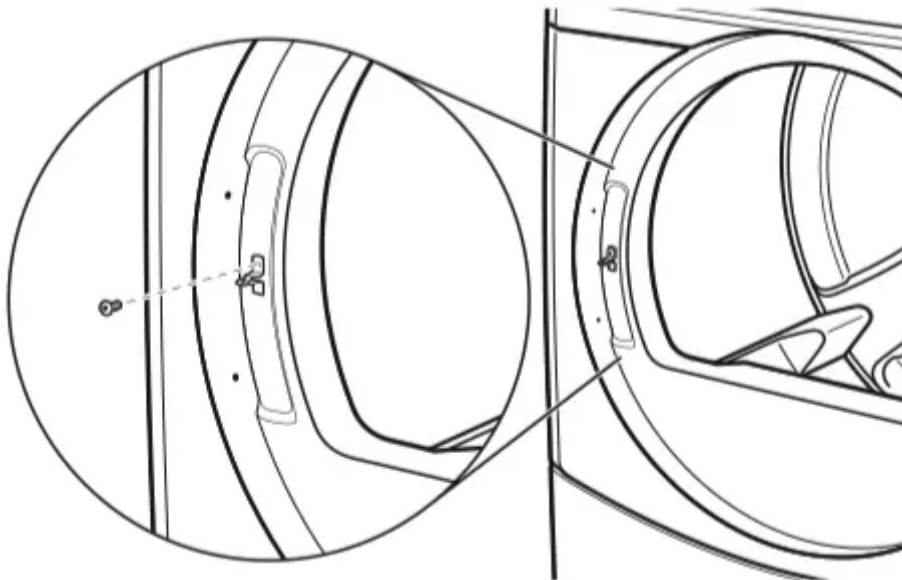

3. Insert strike on the opposite side.

Reinstall the door

1. Partially insert the third screw from onto this screw while hooking the Reattach door to dryer front panel three screws.

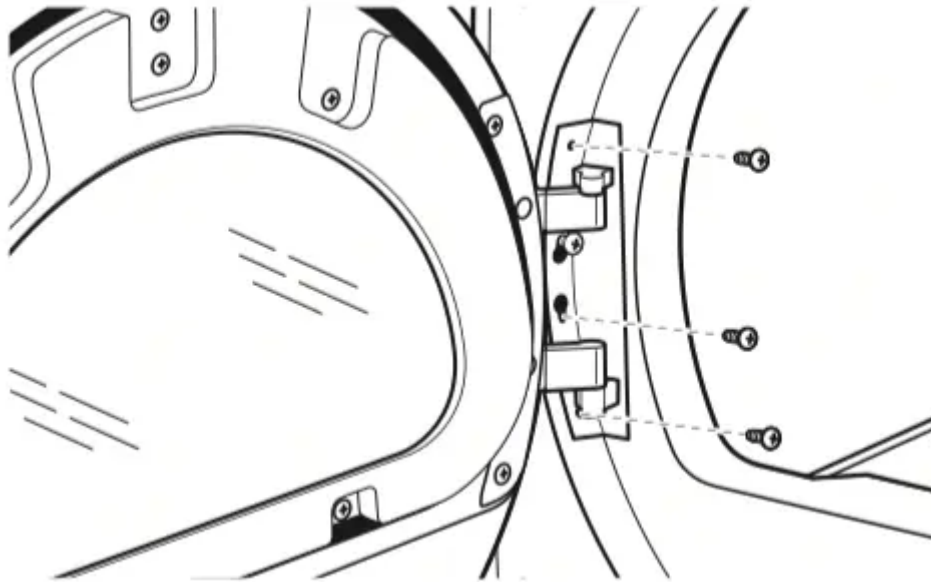

2. Check for fingerprints on the glass. Clean if necessary.
3. Close door and check that it latches securely.

STACKED WASHER/DRYER MAINTENANCE INSTRUCTIONS

Washer

Cleaning the Door Seal/Bellow

1. Open the washer door and remove any clothing or items from the washer.
2. Inspect inner glass door. If debris is present, wipe it off using a damp cloth.
3. Inspect the colored seal/bellow between the door opening and the basket for stained areas. Pull back the seal/bellow to inspect all areas under the seal/bellow and to check for foreign objects.

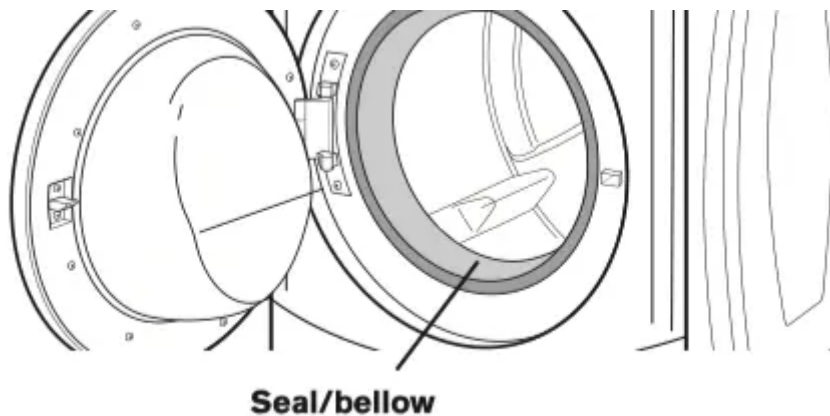

4. If stained areas are found, wipe down these areas of the seal/ bellow:

- a) Mix a dilute solution, using 3/4 cup (177 mL) of liquid chlorine bleach, and 1 gal. (3.8 L) of warm tap water.
- b) Wipe the seal/bellow area with the dilute solution, using a damp cloth.
- c) Let stand 5 minutes.
- d) Wipe down area thoroughly with a dry cloth and let the washer interior air dry with door open.

IMPORTANT:

- Wear rubber gloves when cleaning for prolonged periods.
- Refer to the bleach manufacturer's instructions for proper use.

Maintenance Instructions:

This washer has a special cycle that uses higher water volumes in combination with liquid chlorine bleach to thoroughly clean the inside of the washer.

NOTES:

- Read these instructions completely before beginning the cleaning process.
- If necessary, the cleaning cycle may be interrupted by pressing the Start button twice. However, this will not immediately stop the cycle. The washer will continue with several rinse and drain steps to ensure that all remaining bleach is rinsed from the washer.

To clean washer interior:

1. Open the washer door and remove any clothing or items from the washer.
2. Use liquid chlorine bleach:

Open the dispenser drawer and immediately add 2/3 cup (160 mL) of liquid chlorine bleach to the bleach compartment.

NOTE: Do not add any detergent. Use of more than 2/3 cup (160 mL) of bleach will cause product damage over time.

3. Close the washer door and the dispenser drawer.
4. To start the Washer Cleanout cycle, first enter "Service Mode." Then press and hold the DELICATES button for 2 seconds. Press the EXTRA RINSE button until P-08 is displayed, then press the START button to start the cycle.

To exit out of the service mode and activate the clean wash cycle, push the DELICATES button, then turn the key.

NOTE: The door will lock, the basket will rotate 1/2 turn, then the door will unlock and lock again, then the Washer Cleanout Cycle will continue. The washer will not fill, but the basket will rotate while the washer runs a short sensing cycle. This will take approximately 3 minutes.

5. The cycle will determine whether clothing or other items are in the washer.
 - a) If no items are detected in the washer, it will proceed to Step 7.
 - b) If any items are detected in the washer, "F-34" will be displayed. Then the door will unlock.
 - Enter the service mode and then press and hold the START button to cancel the failure code. Then repeat Steps 1, 3, and 4 to start the cycle again.
6. Once the cycle has begun, allow the cycle to complete.
7. After the cycle is complete, leave the door open slightly to allow for better ventilation and drying of washer interior.

Always do the following to maintain washer freshness:

- Use only HE (High Efficiency) detergent.
- Leave the door slightly open after each cycle to allow for better ventilation and drying of washer interior.
- Clean the washer monthly using the Washer Maintenance Procedure, using 2/3 cup (160 mL) of liquid chlorine bleach.
- If the procedure does not sufficiently improve the washer freshness, please evaluate your installation and usage conditions for other causes.

Cleaning the exterior

Use a soft damp cloth or sponge to wipe up any spills. Occasionally wipe the outside of your washer to keep it looking new. Use mild soap and water. Do not use abrasive products.

Cleaning the dispenser drawer

The dispenser drawer is removable for easy cleaning.

1. Unlock the dispenser drawer for removal by inserting a flat-blade screwdriver into the catch release. Remove the dispenser drawer.
2. Remove the inserts (the siphon from the softener and bleach compartments).
3. Wash the parts under running water.

NOTE: Do not wash components in the dishwasher.

4. Replace the inserts and return the dispenser to the drawer.

Water inlet hoses

Replace the inlet hoses after 5 years of use to reduce the risk of hose failure. Periodically inspect and replace inlet hoses if bulges, kinks, cuts, wear, or leaks are found.

When replacing your inlet hoses, record the date of replacement.



Dryer

Maintenance instructions:

- Clean lint screen before and after each cycle.
- Removing accumulated lint:

From inside the dryer cabinet:

Lint should be removed every 2 years or more often, depending on dryer usage. Cleaning should be done by a qualified person.

From the exhaust vent:

Lint should be removed every 2 years, or more often, depending on dryer usage.

- Keep area around dryer clear and free from combustible materials, gasoline and other flammable vapors and liquids.
- Keep dryer area clear and free from items that would obstruct the flow of combustion and ventilation air.

If dryer does not operate, check the following:

- Electrical supply is connected.
- Circuit breaker is not tripped or house fuse is not blown.
- Door is closed. Listen closely to hear the door switch activate.
- Control is set up properly and display shows cycle time.
- Cycle selection button has been pushed firmly.
- For gas dryers, check that gas supply shut-off valves are set in open position.

ELECTRONIC CONTROL SETUP INSTRUCTIONS



Washer Control



Dryer Control

General Washer/Dryer User Information

NOTE: After the washer/dryer has been installed and plugged in, the display will show "0 MINUTES" on the washer and dryer portions of the display. After the washer and dryer doors have

been opened and closed, the display will show the price for each machine. On washer/dryers set for free cycles, the display sections will flash “SELECT CYCLE.”

1. PD Models: Insert coins until “SELECT CYCLE” flashes on the display portion of the washer or dryer that is to be run.

PR Models: A debit card is required rather than coins. Generation 1 or 2 debit card systems may be used; but when the Generation 2 debit system is used, the controls will automatically be set to Enhanced Debit mode (J. Ed). In Enhanced Debit mode, the card balance will also display when a debit card is inserted into the reader.

2. Door must be closed on the desired washer/dryer before cycle selection is made.

3. Press the fabric setting button for the washer/dryer cycle desired. After the cycle is started, the time will display and count down.

4. If a cycle is interrupted by opening the door or power loss, “RESELECT CYCLE” will flash in the display. To restart the washer/dryer, close door and reselect desired cycle.

NOTE: When set for free vend operation an ongoing dryer cycle will cancel if the door is opened.

Scrolling “OUT OF ORDER” Message, Followed by a Failure or Diagnostic Code Showing in Display

This condition indicates the washer/dryer is inoperative. Diagnostic codes being displayed on the upper portion of the display pertain to the dryer section, and diagnostic codes displayed on the lower portion of the display apply to the washer section. Diagnostic codes displayed on both the upper and lower portions of the display pertain to the control system of both the washer and dryer.

“0 MINUTES” Showing in Display

This indicates the cycle is complete and the washer/dryer cannot be operated. Coins dropped or debit inputs during this condition will be stored in escrow but cannot be used until normal operation is restored by opening and closing the door. If a door switch has failed, causing “0 MINUTES” to remain in the display after the door is opened and closed, it must be replaced before normal operation can be restored.

Warm Start (after power failure)

A few seconds after power is restored, if a cycle was in progress at the time of the power failure, “RESELECT CYCLE” will flash in the display, indicating the need for a key press to restart washer or dryer.

Washer Door Lock

Prior to beginning a cycle, there is a door lock routine of lock/ unlock/relock, then cycle begins. The door will remain locked until the end of a cycle or approximately 2 minutes after a power interruption.

Pricing

After the door is opened and then closed following the completion of a cycle, the display indicates the cycle price (unless set for free operation, where the display will flash "SELECT CYCLE"). As coins are dropped or debit inputs arrive, the display will change to lead the user through the initiation of a cycle.

There are four (4) types of dryer pricing:

Fixed "Vend" Pricing

A dryer setup for "Fixed Cycle" operation can only accept additional time accumulated by increments equal to the length of a complete dry cycle. A maximum of 99 minutes may be purchased; no additional credit is given for coins dropped with 99 minutes in the display.

Accumulator Pricing

If the price is set to one Coin 1, then accumulator pricing is in effect. Cycle time can be purchased one coin at a time (PD models) up to the maximum time of 99 minutes.

Fixed Cycle With Top Off Pricing

A dryer set to offer "Top Off" capability will allow time to be added to an existing dry cycle in increments equal to the number of minutes of dry time per quarter (Coin 1), up to 99 minutes, regardless of the cost required to start the dryer. No credit is given for coins or debit inputs entered when the control is displaying 99 minutes.

PR Models: In Enhanced Debit Mode, the top off price can be set independently (see VALUE OF COIN 2), and the top off time is calculated according to the following equation:

$$\text{top off time} = \frac{\text{top off price}}{\text{full cycle price}} \times \text{full cycle length}$$

Penny increment offset is not applied to top off purchases.

Free Cycles

This is established by setting the cycle price to zero. When this happens, "SELECT CYCLE" will appear rather than a cycle price. Any cycle started as a free cycle will automatically terminate when the door is opened.

Debit Card Ready

This washer/dryer is debit card ready. It will accept a variety of debit card systems, but does not come with a debit card reader. Refer to the debit card reader manufacturer for proper washer/dryer setup. In models converted to a Generation 1 debit card system, debit pulses represent the equivalent of one coin (Coin 1).

Control Set-up Procedures

IMPORTANT: Read all instructions before operating.



PD/PR Models: Insert service switch key and turn counterclockwise.

PR Models: Once a Generation 2 debit card reader is installed (according to the reader manufacturer's instructions), the set-up modes can only be changed by inserting a set-up card (supplied by the reader manufacturer) into the card slot. Inserting the service switch key and turning will only allow access to the service mode. The washer/dryer is now in the set-up mode. The lower fabric setting buttons and the lower portion of the display are used to set up the digital control for the washer. The upper three fabric setting buttons and the upper portion of the display are used to set up the controls for the dryer.

The display can contain four numbers and/or letters and a decimal point on both the top and bottom display portions. These are used to indicate the set-up codes and related code values available for use in programming the washer/dryer.

How to Use the Buttons to Program the Controls

Washer:

1. **POWER WASH**—Upper left button is used to adjust the values associated with set-up codes. Pressing the button will increment the value. Rapid adjustment is possible by holding the button down.
2. **TEMPERATURE**—Lower left button is used to adjust the values associated with set-up codes. Pressing the button will decrement the value. Rapid adjustment is possible by holding down the button.
3. **EXTRA RINSE**—Lower middle button will advance through the set-up codes. Pressing the button will advance to the next available set-up code. Holding the button down will automatically advance through the set-up codes at a rate of 1 per second.
4. **DELICATES**—the right button is used to select or deselect options.

Dryer:

1. **HEAVY DUTY**—Left button is used to adjust the value associated with set-up codes. Pressing the button will increment the value. Rapid adjustment is possible by holding down the button.
2. **DELICATES**—the right button is used to select or deselect options.

Warning

This content is compiled from multiple sources and is provided for reference purposes only. It may not be complete or fully applicable to all situations. If you are unable to resolve your issue, please contact the product manufacturer or an authorized service provider for official support.