

This is manual of HONDA Pioneer.

BASIC OPERATION

Starting & Stopping the Engine

For safety, we recommend that you start the engine in a well-ventilated area. If that is not practical, move the vehicle outdoors as soon as possible. The engine's exhaust contains carbon monoxide, a colorless and odorless gas that can cause illness and even death.

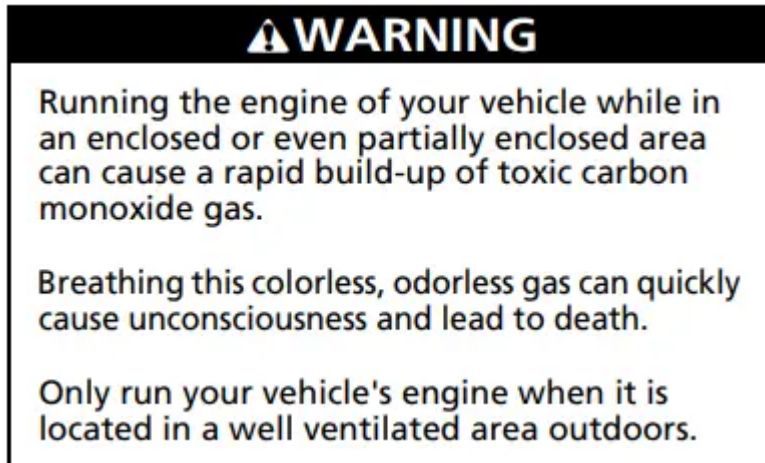

The starter motor will operate when the transmission is in neutral or the brake pedal is pressed.

You should do the following checks and adjustments before you drive your vehicle.

Before START:

1. Make sure the doors, side nets and front hood are securely closed.
2. (SXS520M2 only) Make sure the cargo bed is securely lowered.
3. Check that any items you may be carrying are stored properly or fastened down securely.
4. Fasten your seat belt. Check that your passenger has fastened their seat belt as well.
5. When you start the engine, check the indicators in the instrument panel.

Starting the engine:

1. Apply the parking brake.
2. Press on the brake pedal. Insert the key and turn the ignition switch to the ON (I) position. Confirm the transmission is in neutral, and the neutral indicator is on.
3. To start the engine, without touching the accelerator pedal, turn the ignition switch to the START (II) position.
 - Immediately after the engine starts, let go of the key. The switch returns to the ON (I) position.

- Do not hold the key in the START (II) position for more than 5 seconds at a time.
- If the engine does not start after 5 seconds, turn the key back to the OFF (O) position and wait about 10 seconds before turning it to START (II) again

4. If the engine does not start within 5 seconds, or starts but stalls right away, repeat step 3 with the accelerator pedal pressed halfway down.

- If the engine starts, release pressure on the accelerator pedal so the engine does not race.

5. If the engine fails to start, press the accelerator pedal all the way down, and hold it there while starting to clear flooding. If the engine still does not start, return to step 3.

- The engine can be started with the transmission in gear, the engine will start in gear if the unit is completely stopped, and the brake pedal is pressed.

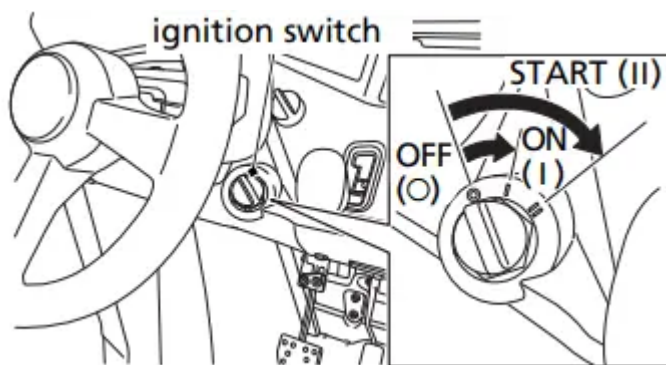

Shifting Gears

Selecting a AT/MT Mode

Your SXS has two transmission modes: AT and MT. You can select the desired shift mode with the AT/MT switch.

- AT mode

This mode automatically shifts the gears with optimal timing according to your driving conditions.

The gear position indicator shows “D” for forward gears, “N” for neutral, and “R” for reverse. Select gear position with the right side upshift paddle and left side downshift paddle.

You can temporarily shift up or down by operating the shift paddles while driving in AT mode. At the same time, the shifted gear is shown on the gear position indicator.

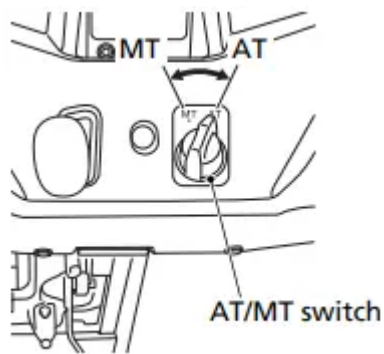

- MT mode

In this mode, the gears are shifted manually through shift paddle operation.

You can select five forward gears, neutral and reverse by operating the right side upshift paddle and left side downshift paddle.

The gear position indicator will show “1, 2, 3, 4, or 5” for forward gears, “N” for neutral, and “R” for reverse.

- Holding the shift paddle does not continuously shift the gears. To continue shifting, release your fingers from the shift paddle, and then pull the shift paddle again.
- The gears do not shift up automatically in MT mode. Do not allow the engine to exceed the rev limit.
- The gears shift down automatically when you slow down, even in MT mode.

NOTICE

Improper shifting can damage the engine, transmission, and drive train. Also, coasting or towing the SXS for long distance with the engine off can damage the transmission.

Driving in AT mode

After starting the engine and letting it warm up, follow these procedures:

1. With the transmission in neutral, release the parking brake, but continue to press the brake pedal.
2. With the throttle closed, select AT mode, and then pull the right side upshift paddle once to shift into drive (D). Make sure the gear position indicator shows “D”.
3. Release the pressure from the brake pedal and increase engine speed by gradually pressing the accelerator pedal.

GEAR SHIFTING SEQUENCE

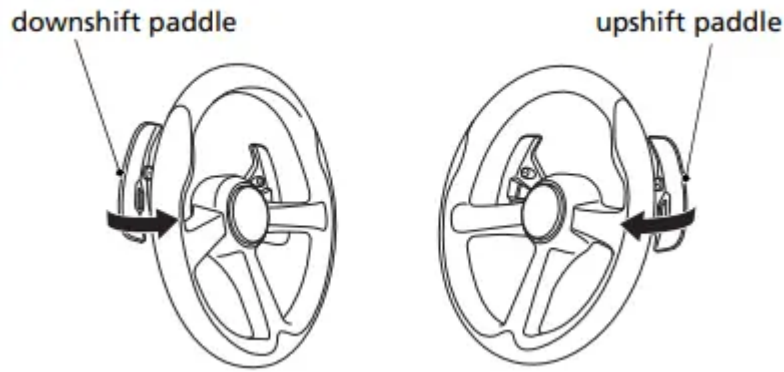

The transmission cannot be upshifted from neutral to D gear when the engine speed is above 3,000 rpm or the ground speed is above 2 mph (3 km/h) or the accelerator pedal is pressed.

If the gear position indicator shows "-", shift the gear by pulling the gearshift paddles.

Temporarily changing gears by operating the shift paddle while AT mode is selected

You can temporarily change gears by operating the shift paddles even while AT mode is selected.

When operating the shift paddles while AT mode is selected, the D displayed in the gear position indicator changes to a gear position number (1 – 5).

Because the gear change is temporary, the vehicle automatically returns to normal AT mode under the following conditions:

- When the shift paddles are not operated for a prescribed time
- When the vehicle speed is reduced or increased beyond the automatic shifting speed

Driving in MT mode

To upshift the transmission, pull the right side upshift paddle once.

To downshift the transmission, pull the left side downshift paddle once.

After starting the engine and letting it warm up, follow this procedure:

1. With the transmission in neutral, release the parking brake, but continue to press the brake pedal.
2. With the throttle closed, select MT mode, and pull the upshift paddle once to shift into 1st gear.
3. Release pressure from the brake pedal and increase engine speed by gradually pressing the accelerator pedal.
4. When speed increases, shift to 2nd gear by pulling the upshift paddle once. Lifting off the throttle is recommended, but not required.
5. Repeat this sequence to progressively upshift to 3rd, 4th and 5th (top) Gear.
6. To downshift, pull the downshift paddle once. Remember to lift off the throttle each time you shift to the next lower gear.

The transmission cannot be upshifted from neutral to 1st gear when the engine speed is above 3,000 rpm or the ground speed is above mph (3 km/h) or the accelerator pedal is pressed.

If the electric shift system malfunctions, the transmission cannot be shifted by pulling the gearshift paddles. See your dealer. (In an emergency, a gear may be selected manually so you may move the vehicle.

Driving in Reverse

If you need to drive in reverse, make sure the area behind you is clear and only operate the SXS at low speed.

1. Bring the SXS to complete stop (the transmission cannot be shifted into reverse if the vehicle is moving). Make sure the transmission is in neutral.
2. Be sure there are no obstacles or people in the way.
3. While pulling the reverse lever and depressing the brake pedal, pull the downshift paddle once to shift into "R" (reverse) gear.
4. Make sure that the reverse indicator comes on.
5. Release the brake pedal and reverse lever.
6. Press the accelerator pedal gradually to increase speed.
7. To stop, lift off the accelerator pedal and press the brake pedal.
8. To shift out of reverse and into neutral, pull the upshift paddle once to shift into "N" (neutral) gear. Make sure that the reverse indicator goes off. To stop the engine, turn the ignition switch to the OFF (O) position. Remember to apply the parking brake and remove the key if you plan to leave the vehicle.

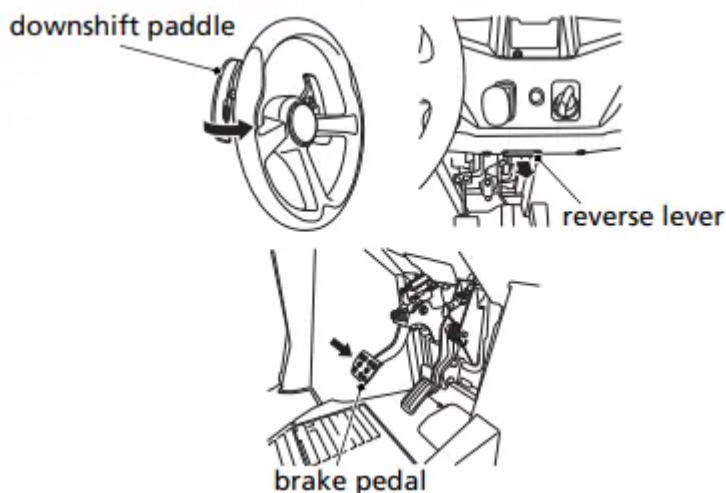

Selecting a Drive Mode

2WD	This mode supplies power to the rear wheels only, this mode is best for surfaces with good traction.
4WD	This mode supplies power to the front and rear wheels. Steering will require slightly more effort than with 2WD. This mode is recommended for driving on surfaces with poor traction

Before using the drive mode select lever to change from one mode to another, be sure the vehicle is stopped and the engine is idling.

Parking

Look for a level parking area with a firm surface. Avoid parking on a slope or on loose or slippery surfaces when possible. If you must park on a slope, block the wheels to help keep the vehicle from sliding.

After bringing your vehicle to a stop:

1. Keep your foot on the brake pedal while you shift into neutral (N).
2. Set the parking brake.
3. Turn the ignition switch to the OFF (O) position, and remove the key.

Fully push the parking brake lever down when releasing the parking brake.

Your Honda SXS has been designed with many safety features to help protect you. These include a strong occupant protection structure, seat belts, doors, and side nets. However, no safety system can prevent all injuries.

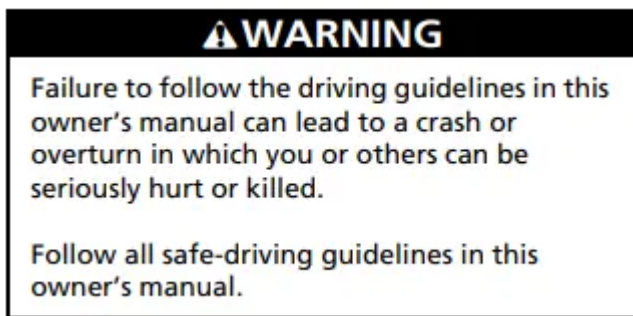

Safe Driving Precautions

We also recommend that you complete the Recreational OffHighway Vehicle (ROV) E-Course. The free course is available at www.ROHVA.org. The two-hour ROV E-Course is a multi-media, interactive, online safety course that reinforces:

- Key risk factors associated with ROV operation
- Safe driving practices that will reduce risk of injury
- The best resources for learning about your particular vehicle

DRIVING GUIDELINES

Off-highway Use Only

Your Honda SXS was designed for use on a wide variety of terrain and situations. However, it should not be driven on any public road, paved or unpaved, because it is not equipped to legally or safely drive on such roads.

Remember to obey all local off-road regulations, obtain permission before driving on someone else's private property, and respect all "no trespassing" signs.

Control Speed

Driving at excessive speed for the terrain or other conditions increases the chance of a crash or overturn. Always reduce speed when driving on hilly terrain, or when carrying cargo or towing a trailer.

Use Extra Care on Unfamiliar Terrain

When driving in a new area, keep your speed low and check the terrain ahead for possible problems, such as large rocks, bumps, holes, or drop-offs. Don't drive fast on unfamiliar terrain or when visibility is limited. If you drive in an area with other vehicles, be sure to keep a safe distance to avoid a collision.

Do Not Perform Stunts

Keep all four wheels on the ground at all times. Showing off or attempting to perform stunts could lead to a crash or overturn in which the driver, a passenger, or others could be seriously hurt or killed.

Off-road Driving Considerations

Your Honda SXS was designed and intended for off-road use. In the event that you must drive on a paved surface, be aware that your

Honda SXS will feel and handle different than it does on dirt. The tires will also wear much faster.

Vehicle Design

The Honda SXS handles somewhat differently from on-highway vehicles due in part to features that allow it to perform its role as an off-highway recreational vehicle. For example, this Honda SXS has a higher center of gravity than cars designed for use only on pavement. It is also equipped with large low-pressure tires that allow good traction in sand, loose dirt, wet grass and other low-traction surfaces.

These advantages come at some cost. Because your vehicle is taller and rides higher off the ground, it can more easily tip or roll over if you make abrupt turns or drive on sloped terrain.

Off-highway Environments

Driving on private property, or in approved off-highway areas, means you leave a generally predictable and orderly world behind.

You won't find lane markers or traffic signals, and no one will be there to warn you of trouble ahead. It's up to you to assess situations and drive within limits. The terrain has limits (it may be too steep or bumpy, for example). The vehicle has limits (e.g., traction, stability, and power). And you may be limited by lack of experience.

Surface Considerations

The kind of surface you drive on can have important effects on how your vehicle handles. For example, on loose or soft surfaces you'll need more time and distance to accelerate, turn, or brake to a stop.

Avoid any sudden sharp turn, particularly on pavement and other hard surfaces. And always slow down after moving from one type of surface to another until you get accustomed to how your vehicle handles.

Reading the Terrain

Because visual information comes in unpredictable ways off-road, you need to stay alert, constantly survey the terrain, and go slow enough to analyze situations and make good decisions.

As your eyes search the terrain ahead, watch for changes in surface conditions. One minute you can be on firm soil and the next in soft sand or deep mud. A path can quickly change from level to bumpy, slope at a dangerous angle, or disappear in a drop-off. Always keep your eyes open for holes, washouts, or obstacles that could upset or damage the vehicle.

Of course, if you cannot see clearly, due to tall grass for example, stop safely, get out of the vehicle, and survey the area for a safe route.

Controlling Speed

Whether you travel off-road or on pavement, the general rule is to keep your speed low. Of course, you'll need enough speed to keep moving forward, but too much speed leads to problems.

When driving off-road at higher speeds, you have less time to read the terrain and make good decisions. The drive can also be more bumpy, and there's a greater chance of the vehicle sliding if you brake or turn quickly on wet soil, gravel, or another slippery surface.

Never go faster than conditions allow.

Driving with Cargo or Pulling a Trailer

The added weight of carrying cargo or pulling a trailer will affect how your vehicle accelerates, brakes, and handles. The added weight and length of a trailer will affect your directional control.

Please follow these guidelines whenever you carry cargo or pull a trailer:

- Do not exceed the cargo limit and towing limits.
- Keep speed low, particularly when driving on hills.

- Allow extra distance to accelerate, turn and slow or stop.
- Do not drive across a steep slope with a trailer.
- Use lower gears when towing a trailer or carrying extra cargo

Basic Driving

Making Turns

The basic turning technique for Honda SXS is to drive at low speed and gradually adjust the amount of steering to suit the surface. Do not make sudden sharp turns, either off-road or on pavement.

If your vehicle ever skids sideways during a turn, steer in the direction of the skid. Also, avoid hard braking or accelerating until you have regained directional control.

Braking

The best off-road braking technique is to gently step down on the brake pedal, then increase pressure as more braking is needed. Light braking may be all you need on soft surfaces, such as sand or loose dirt. Avoid hard braking on any surface.

Driving on Hills

Hills present some of the greatest challenges and hazards, especially if you are carrying cargo or pulling a trailer. If you are new to offroad driving, start with gentle inclines, take time to learn how your vehicle handles on slopes, and read the information that follows.

Even if you have previous off-road driving experience, the guidelines below should serve as important reminders.

Approaching a Hill

When you approach a hill, you need to decide whether it is one that you, your passenger, your cargo and your vehicle can handle. For example, ask yourself:

- Is the hill too steep? Is the incline constant, or are there places where it gets suddenly steeper? If you run out of power, you may not be able to continue forward.
- Is there enough traction for you to make it to the top without spinning the wheels or sliding backwards?
- Are there obstacles, such as rocks or ruts, that could upset your vehicle and make it roll over?
- If there is no safe predetermined path, can you drive straight up the hill without turning?
- Do you know what is on the other side of the hill?

If you do not know the answers to these questions before beginning an ascent, you should stop and walk up the hill to find out.

Driving Up a Hill

If you decide that it is safe to drive your Honda SXS up a hill:

- Select an appropriate gear and drive mode for the hill.
- Approach the hill with enough speed to smoothly start up the hill.
- Maintain a steady speed as you climb the hill.
- Reduce speed as you approach the top, and watch for other vehicles that may be approaching the top from the other side of the hill.

If You Stall Going Up a Hill

If a hill is steeper than you expected, traction is poor, or you don't maintain sufficient speed, you may begin to stall. If that happens:

- Stop the vehicle and set the parking brake.
- If you have a passenger, you may want to have them get out and move away from the vehicle.
- If you are headed straight up the hill, shift into reverse, release the parking brake, and slowly back straight down the hill, gently using the brake pedal to control speed.

Driving Down a Hill

Before driving down a hill, as with driving up a hill, you need to evaluate whether you can make it safely to the bottom and away from the slope.

Ask yourself:

- Is the hill too steep to maintain speed and steering control?
- Is the surface too rough or too slippery?
- Can you drive straight down without turning?
- Is there a safe exit when you reach the bottom of the hill?

If you decide it is safe to drive down a hill:

- Hold the steering wheel firmly and drive straight back down the hill.
- Gently apply the brakes to help control speed, but do not "ride" the brakes.

Crossing a Hill

Before traversing a hill, consider these facts:

- A hill that you can drive straight up or down can be too steep to drive across.
- When you drive straight up or down a slope, the length of the wheelbase reduces the chance of tipping over backward or forward, but when you drive across a slope, the vehicle's narrower track and higher center of gravity increases the chance of tipping or rolling over.
- If you drive across a slope and an uphill wheel hits a bump, or a downhill wheel drops into a hole, your vehicle will tip downward even more.

If you can't clearly see all terrain conditions (good traction, no bumps, holes or other obstacles, etc.), stop and walk the slope before you drive on it. If you have any doubt whether you can safely drive across a slope, don't do it. Find another route.

Avoiding Obstacles

When driving off-road, always watch for bumps, pot holes, rain ruts and other obstacles. Large bumps and holes can bounce you around and cause you to lose control or get stuck. Slow down whenever you drive on rough terrain.

Driving Through Water

Before driving through water, stop and make sure that:

- The water is not more than about 10 inches (25 cm) deep.
- The water is not flowing too fast. Deep rushing water can sweep you downstream. Even very shallow rushing water can wash the ground from under your tires and cause you to lose traction and possibly roll over.
- Both banks have gradual slopes and good traction, so you can enter the stream and exit safely.
- The surface under the water appears to provide good traction.
- Remember, the water may hide hazards, such as rocks, holes, mud, or slippery vegetation.

If you decide you can safely cross the water:

- Proceed at a slow, steady speed.
- Watch for submerged obstacles, including slippery rocks and holes.
- Avoid getting the spark plug or air cleaner wet, as this would cause the engine to stop.

Driving at Night

If you drive your Honda SXS at night, always drive slower and more cautiously than you would in daylight.

MAINTENANCE

Maintenance Schedule

Initial Maintenance

Appears at 100 miles (150 km) or 20 operating hours, whichever comes first.

Regular Maintenance Interval 1

Appears 600 miles (1,000 km) or 100 operating hours after the Initial Maintenance is performed and maintenance minder is reset

Regular Maintenance Interval 2

Appears 600 miles (1,000 km) or 100 operating hours after the Initial Maintenance Interval 1 is performed and maintenance minder is reset

Service the items listed at the indicated distance (or time, if given).											
		Initial maintenance	Regular maintenance interval								
FREQUENCY (Whichever comes first)	x100 mi	1	6	12	18	24	30	36	Note	Refer to page	
	x100 km	1.5	10	20	30	40	50	60			
	Hours	20	100	200	300	400	500	600			
	Month	1	12								
ITEMS											
	Check engine oil and coolant	Check oil and coolant at fuel stop									125, 137
	Check tires	Check inflation and condition once a month									176
	Check side net adjustment and snap hooks	●	●	●	●	●	●	●		42	
*	Reverse inhibitor system	●	●	●	●	●	●	●		157	
	Check brake fluid	Check fluid level once a month									169
	Replace engine oil and oil filter	●	●	●	●	●	●	●		127	
*	Inspect valve clearance	●	Every 600 miles (1,000 km) or 100 operating hours, otherwise adjust only if noisy							—	
*	Clean spark arrester		Every 600 miles (1,000 km) or 100 operating hours, whichever comes first							162	
	Clean air cleaner elements								1	142, 145	
	Check air cleaner housing drain tube								2	148, 149	
	Check spark plug									159	
*	Inspect idle speed	●								—	
*	Check fuel lines and connections			●		●		●		—	
	Check front and rear brakes	●			●			●	3	168	
	Check front and rear final gear oil	●			●			●		132, 134	

Service the items listed at the indicated distance (or time, if given).											
		Initial maintenance	Regular maintenance interval								
FREQUENCY (Whichever comes first)	x100 mi	1	6	12	18	24	30	36	Note	Refer to page	
	x100 km	1.5	10	20	30	40	50	60			
	Hours	20	100	200	300	400	500	600			
	Month	1	12								
ITEMS											
	Lubricate all hinges, latches, and pivots	●	●	●	●	●	●	●		150	
**	Inspect the following items: Suspension components Wheels Driveshaft boots Accelerator and brake pedals									— — 183 184 155, 172 174 163 186	
	Check parking brake adjustment	●							●	173	
**	Inspect the following items: Tie-rod ends									—	
*	Steering gearbox and boots								●	—	
*	Brake hoses and lines									—	
*	SXS underbody									4 —	
*	Inspect evaporative emission control system (USA - 50 states [meets California])		Every 2 years (regardless of mileage)								—
	Replace the following items: Front and rear final gear oil		Every 2 years (regardless of mileage)								— 133, 135 139 —
*	Engine coolant		Every 2 years (regardless of mileage)								—
*	Brake fluid		Every 2 years (regardless of mileage)								—

Engine Oil & Filter

API classification	SG or higher except oils labeled as energy conserving or resource conserving on the circular API service label
viscosity (weight)	SAE 10W-30
JASO T 903 standard	MA
suggested oil*	Pro Honda GN4 4-stroke oil (USA & Canada) or Honda 4-stroke oil, or an equivalent motorcycle oil.

*Suggested oils are equal in performance to SJ oils that are not labeled as energy conserving or resource conserving on the circular API service label.

- Your Honda SXS does not need oil additives. Use the recommended oil.

- Do not use oils with graphite or molybdenum additives. They may adversely affect clutch operation.
- Do not use API SH or higher oils displaying a circular API “energy conserving” or “resource conserving” service label on the container. They may affect lubrication and clutch performance.
- Do not use non-detergent, vegetable, or castor based racing oils.

Other viscosities shown in the following chart may be used when the average temperature in your driving area is within the indicated range.

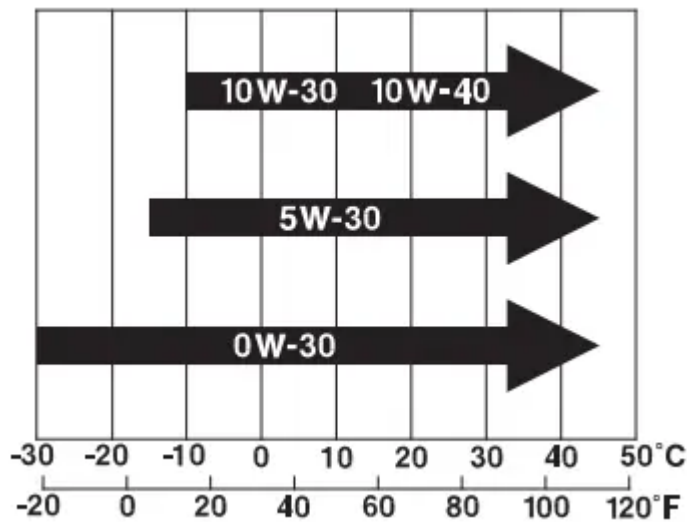

JASO T 903 standard

The JASO T 903 standard is an index for engine oils for 4-stroke motorcycle engines.

There are two classes: MA and MB.

Oil conforming to the standard is labeled on the oil container. For example, the following label shows the MA classification.

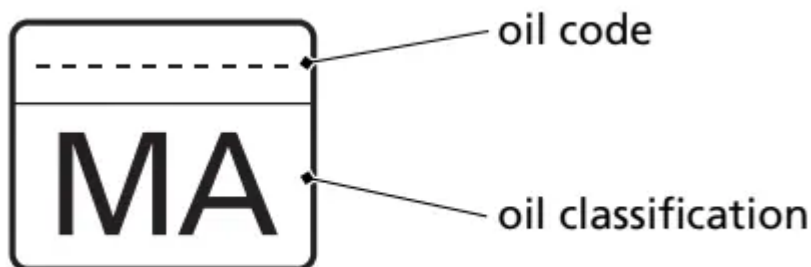

Checking & Adding Oil

Check the engine oil level each day before operating your Honda SXS and add, if needed.

Before driving your SXS, check the engine oil level.

1. Park your Honda SXS on a firm, level surface.
2. Start the engine in a well-ventilated area and let it idle for 3 – 5 minutes. Stop the engine and wait 2 – 3 minutes.
3. Remove the seat bottom and fold open the rubber dust cover on the left side.
4. Remove the oil filler cap/dipstick from the front crankcase cover and wipe it clean.
5. Insert the oil filler cap/dipstick without screwing it in, then remove the dipstick and check the oil level. The oil level should be between the upper level mark and the lower level mark on the dipstick.
6. If required, add the specified oil into the fill cap hole, up to the upper level mark on the dipstick. Do not overfill.
7. Reinstall the oil filler cap/dipstick, rubber dust cover and seat bottom.

UNDER SEAT BOTTOM

LEFT SIDE

Drain the Engine Oil:

1. Make sure the Honda SXS is parked on level ground. Set the parking brake, and jack up and support your Honda SXS.
2. Remove the seat bottom and fold open the rubber dust cover.
3. Remove the oil filler cap/dipstick.

UNDER SEAT BOTTOM

LEFT SIDE

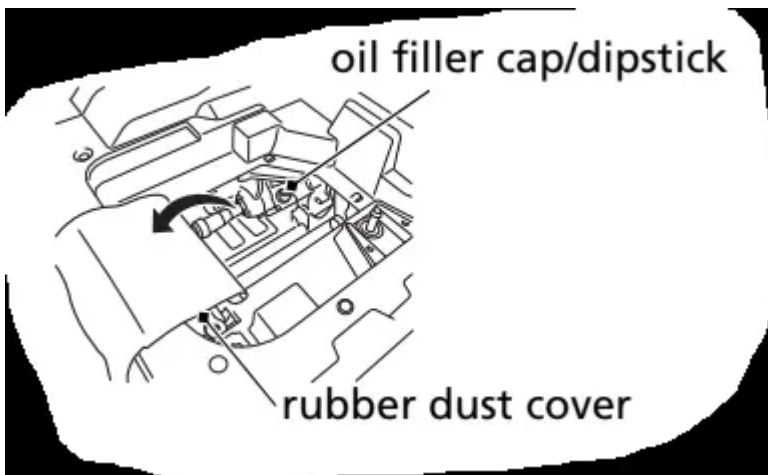

4. Place an oil drain pan under the crankcase.
5. Remove the engine oil drain plug and sealing washer.

UNDER BODY

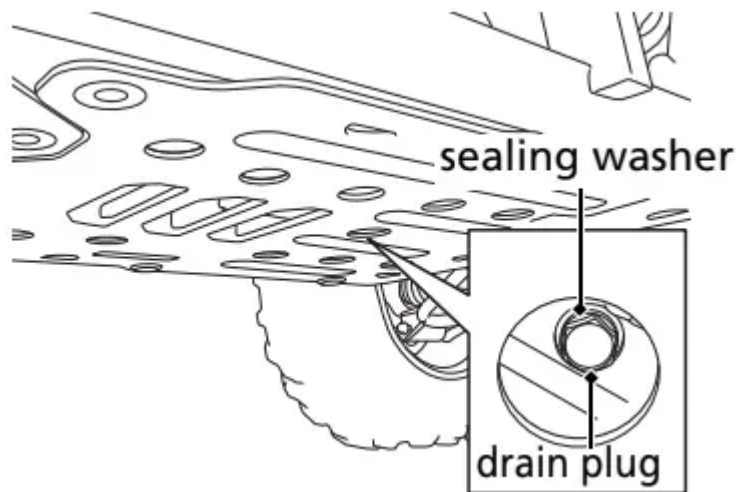

Install a New Engine Oil Filter:

6. Remove the seat back
7. Remove the center rear panel
8. Remove the clips and screws from right seat bottom cover and flip it forward leaving ECU and wiring in place. The oil filter can be accessed on right side of engine.

UNDER SEAT BOTTOMRIGHT SIDE

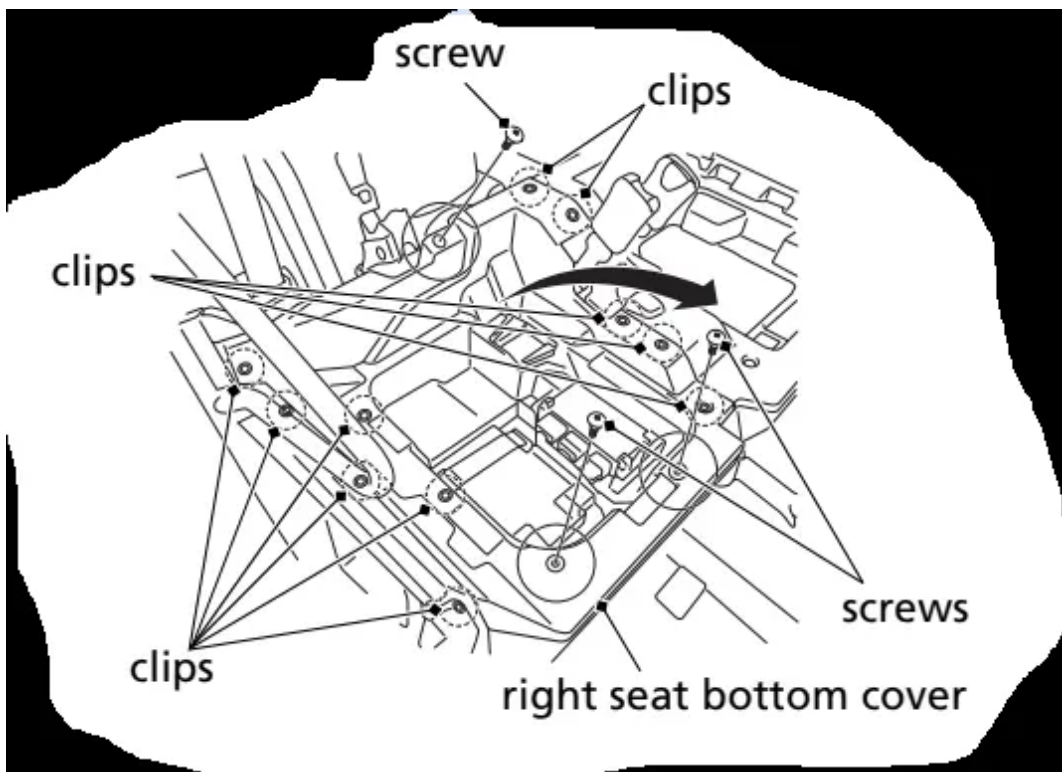

9. Remove the oil filter cover by removing the bolts. Let the remaining oil drain out. Discard the oil filter in an approved manner.

10. Coat new O-rings with engine oil and install them into each groove in the filter cover and crank case.

11. Reposition the spring to the engine crankcase and install a new oil filter with the rubber seal facing out, away from the engine.

- You will see the “OUT-SIDE (TOWARD FILTER COVER)” mark on the filter body, near the seal.
- Use only the Honda Genuine oil filter or a filter of equivalent quality specified for your model.
- Using the wrong Honda filter or a non-Honda filter which is not of equivalent quality may cause engine damage.

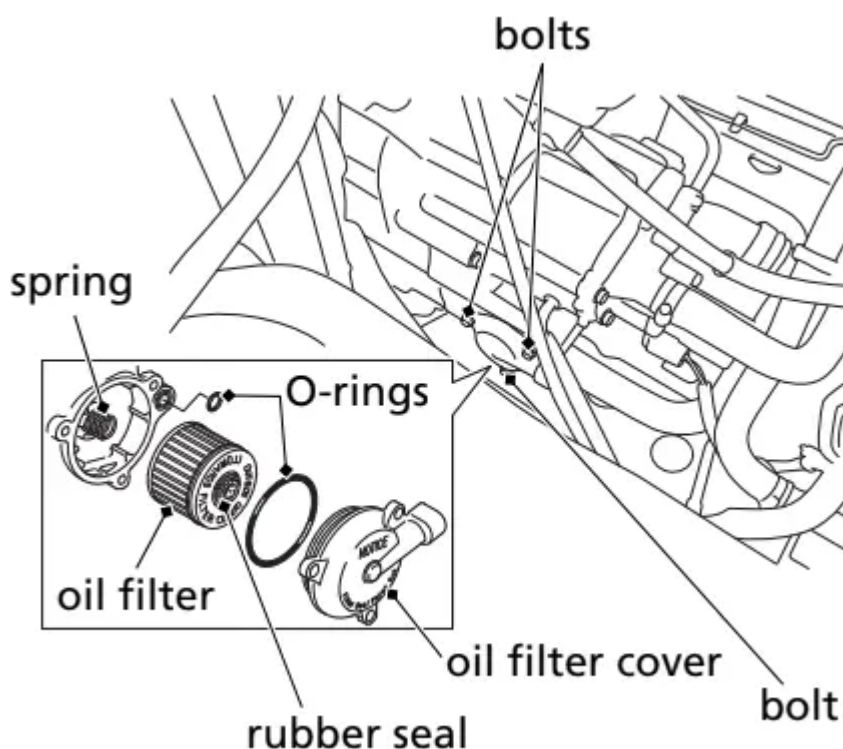

12. Reinstall the oil filter cover, making sure the bolts are tightened to the specified torque: **9 lbf·ft (12 N·m, 1.2 kgf·m)**

13. Pour the drained oil into a suitable container and dispose of it in an approved manner.

NOTICE Improper disposal of drained fluids is harmful to the environment.

14. Install the right seat bottom cover by flipping it back. Install the clips. Install the screws and tighten them to the specified torque: **5.9 lbf·ft (8 N·m, 0.8 kgf·m)**

15. Install the center rear panel.

16. Install the seat back.

Add Engine Oil:

17. Reinstall the drain plug with a new sealing washer, and tighten the drain plug to the specified torque: **18 lbf·ft (25 N·m, 2.5 kgf·m)**
 18. Lower your Honda SXS safely.
 19. Fill the crankcase with the recommended oil, approximately: **3.2 US qt (3.0 l)**
 20. Reinstall the oil filler cap/dipstick.
 21. Reinstall the rubber dust cover.
 22. Reinstall the seat bottom.
 23. Start the engine and let it idle for 3 – 5 minutes.
 24. Remove the seat bottom and fold open the rubber dust cover.
 25. Stop the engine and after 2 – 3 minutes, check the oil level. Make sure the oil is between the upper and lower level marks on the dipstick. If necessary, add more oil but do not overfill.
 26. Reinstall the oil filler cap/dipstick and rubber dust cover.
 27. Reinstall the seat bottom.
 28. Check that there are no oil leaks.
- If a torque wrench is not used for installation, see your dealer as soon as possible to verify proper assembly.

Front Final Gear Oil

Checking Oil

1. Park your Honda SXS on a firm, level surface.
2. Remove the oil filler cap.
3. Make sure the oil level is at the lower edge of the oil filler inspection hole.
4. Apply a thin coat of grease to a new O-ring, and insert it into the oil filler cap groove.
5. Install and tighten oil filler cap to the specified torque: lbf·ft (12 N·m, 1.2 kgf·m)

LEFT FRONT

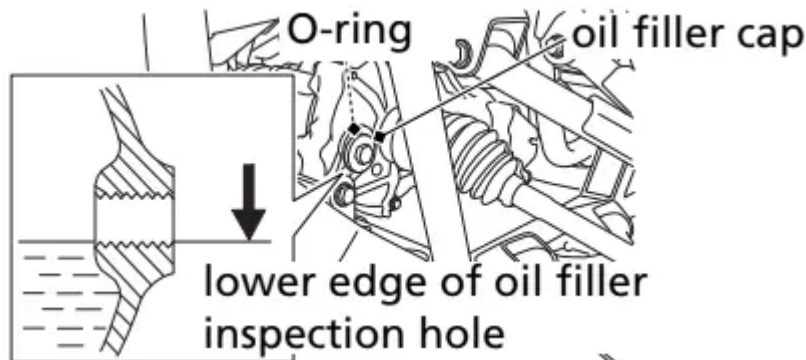

Changing Oil

Change the oil with the front final gear at normal operating temperature to assure complete and rapid draining.

1. Park the Honda SXS on a firm, level surface.
2. Place an oil drain pan under the oil drain plug.
3. Remove the oil filler cap and the drain plug.
4. After the oil has completely drained (3 – 5 minutes), reinstall the drain plug with a new sealing washer and tighten it to the specified torque: **9 lbf·ft (12 N·m, 1.2 kgf·m)**
5. Fill the front final gear with the recommended oil. **17.2 US oz (510 cm³)**
6. Make sure the oil level is at the lower edge of the oil filler inspection hole.
7. Apply a thin coat of grease to a new O-ring, and insert it into the oil filler cap groove.
8. Install and tighten oil filler cap to the specified torque: **9 lbf·ft (12 N·m, 1.2 kgf·m)**
9. Pour the drained oil into a suitable container and dispose of it in an approved manner

LEFT FRONT

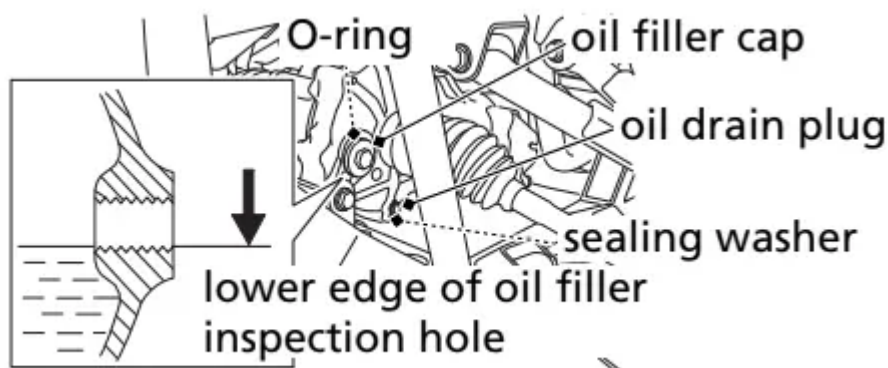

Rear Final Gear Oil

Checking Oil

Check the rear final gear oil level every 1,800 miles (3,000 km) or hours of operating your Honda SXS, and add if needed.

1. Park your Honda SXS on a firm, level surface.
2. Remove the oil filler cap.
3. Make sure the oil level is at the lower edge of the oil filler inspection hole.
4. Apply a thin coat of grease to a new O-ring, and insert it into the oil filler cap groove.
5. Install and tighten oil filler cap to the specified torque: **9 lbf·ft (12 N·m, 1.2 kgf·m)**

RIGHT REAR

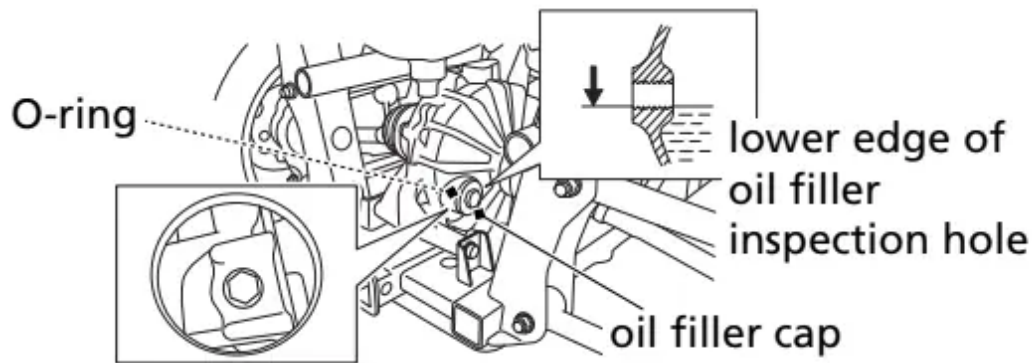

Changing Oil

1. Park the Honda SXS on a firm, level surface.
2. Place an oil drain pan under the oil drain plug.
3. Remove the oil filler cap and the drain plug.
4. After the oil has completely drained (3 – 5 minutes), reinstall the drain plug with a new sealing washer and tighten it to the specified torque: **9 lbf·ft (12 N·m, 1.2 kgf·m)**
5. Fill the front final gear with the recommended oil. **5.1 US oz (150 cm³)**
6. Make sure the oil level is at the lower edge of the oil filler inspection hole.
7. Apply a thin coat of grease to a new O-ring, and insert it into the oil filler cap groove.
8. Install and tighten oil filler cap to the specified torque: **9 lbf·ft (12 N·m, 1.2 kgf·m)**
9. Pour the drained oil into a suitable container and dispose of it in an approved manner

Coolant

Checking & Adding Coolant

Check the engine coolant level every day before operating your Honda SXS and add, if needed.

1. Make sure the vehicle is parked on a firm, level surface.
2. Remove the front hood
3. With the engine at normal operating temperature, check the coolant level in the reserve tank. It should be between the MAX and MIN level marks. If the reserve tank is empty, or if coolant loss is excessive, check for leaks and see your dealer for repair.
4. Remove the reserve tank cap. Always add coolant to the reserve tank. Do not attempt to add coolant by removing the radiator cap.

UNDER FRONT HOOD

RIGHT FRONT

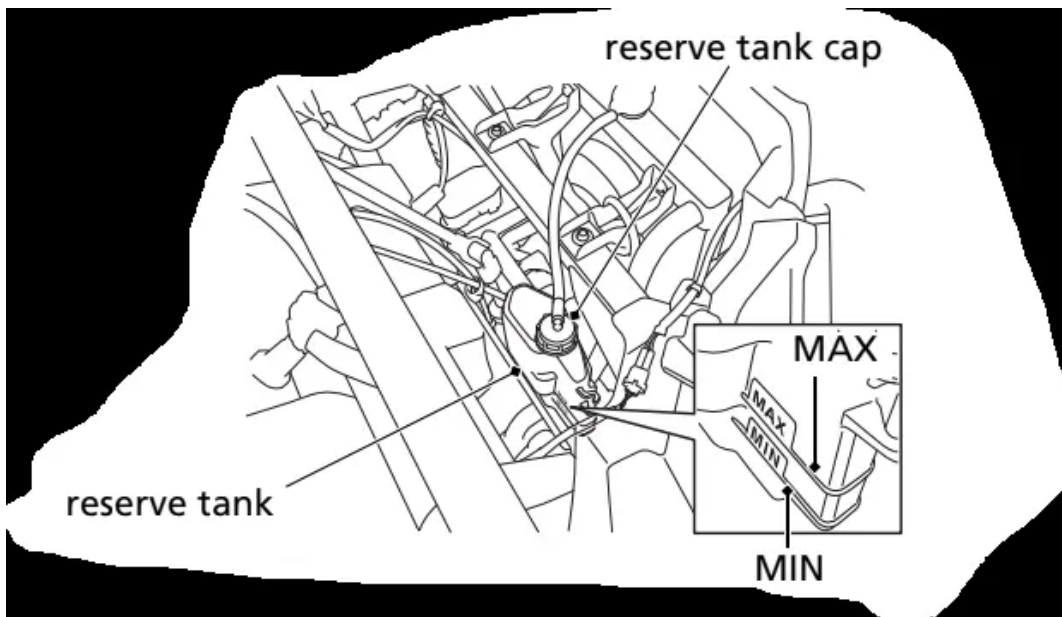

5. Add coolant to the reserve tank as required to bring the coolant level to the MAX level mark.
6. After adding coolant, install the reserve tank cap and install the front hood.

Air Cleaner

Cleaning

1. Lift the cargo bed.
2. Unlatch the retainer clips.
3. Remove the air cleaner housing cover.

UNDER CARGO BED

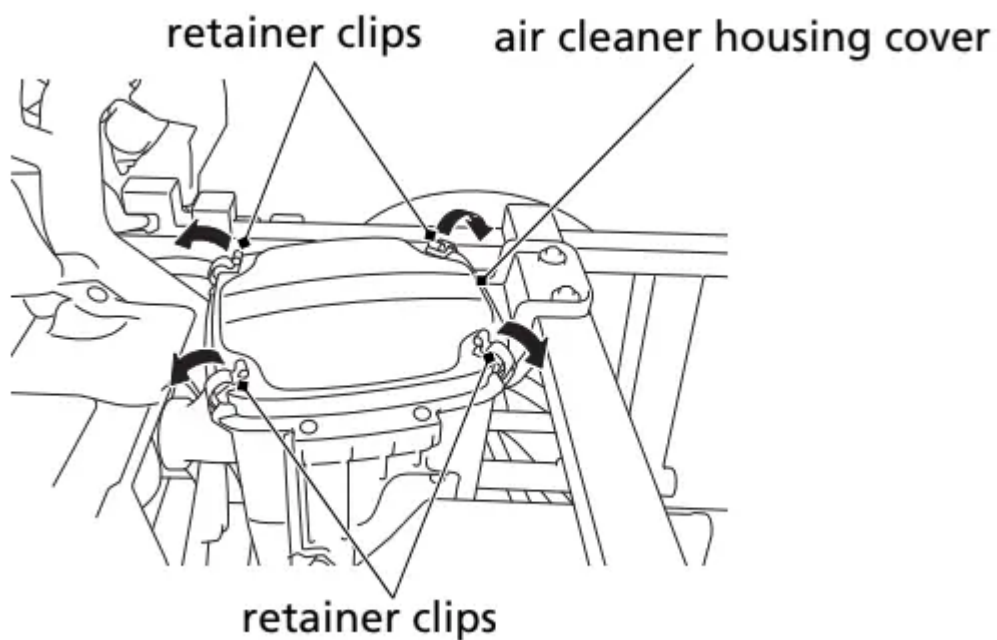

4. Loosen the screw and remove the air cleaner assembly from the air cleaner housing.
5. Unscrew the clamp.
6. Remove the air cleaner from the air cleaner body.
7. Gently wash the air cleaner with the Pro Honda Air Filter cleaner or an equivalent. Do not use kerosene or gasoline. After cleaning, gently squeeze out the remaining solvent. Avoid twisting or wringing the air cleaner. This can tear the foam.
8. Inspect for tears or cracks in the foam or seams of the air cleaner. Replace the air cleaner if it is damaged.

UNDER CARGO BED

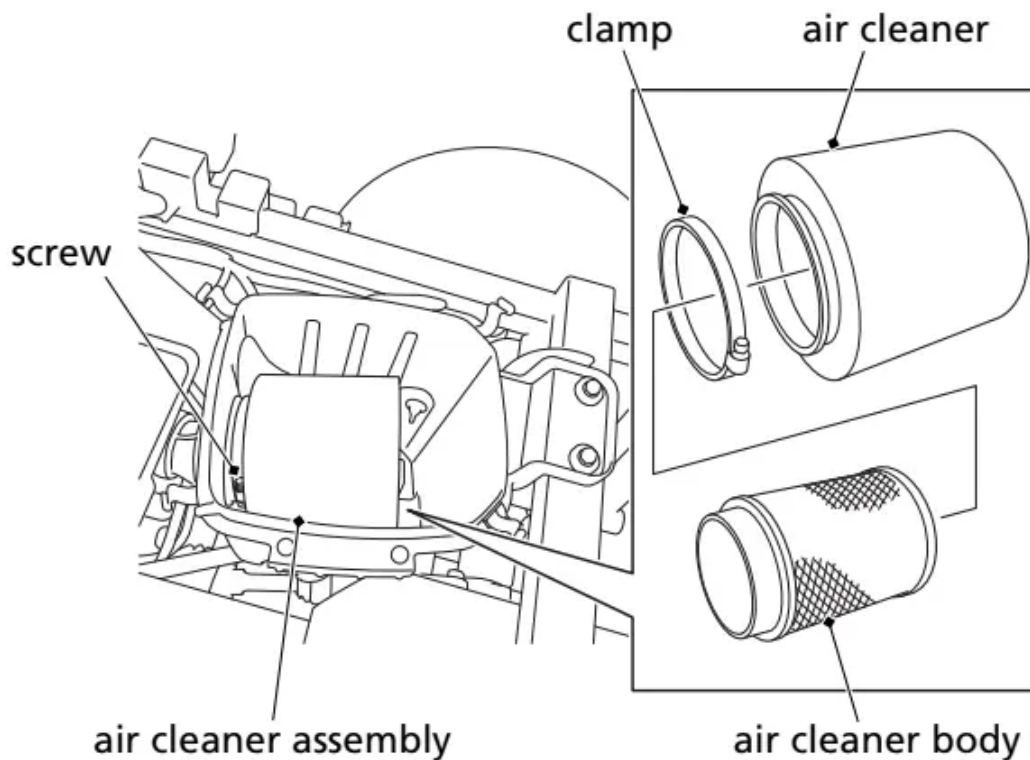

9. Allow the air cleaner to dry thoroughly before applying oil. A wet air cleaner will not fully absorb the oil.
10. Pour clean Pro Honda Foam Filter Oil or an equivalent over the entire surface of the air cleaner. Use both hands to evenly spread the oil into the air cleaner. Gently squeeze out any excess oil. (To keep your hands dry, place the air cleaner in a clean plastic bag before spreading the oil into the air cleaner.)
11. Install the air cleaner on the air cleaner body.
12. Install the clamp.
13. Insert the air cleaner assembly into the air cleaner housing.
14. Fasten the screw.
15. Reassemble in the reverse order of removal.
16. Lower the cargo bed.

UNDER CARGO CARRIER

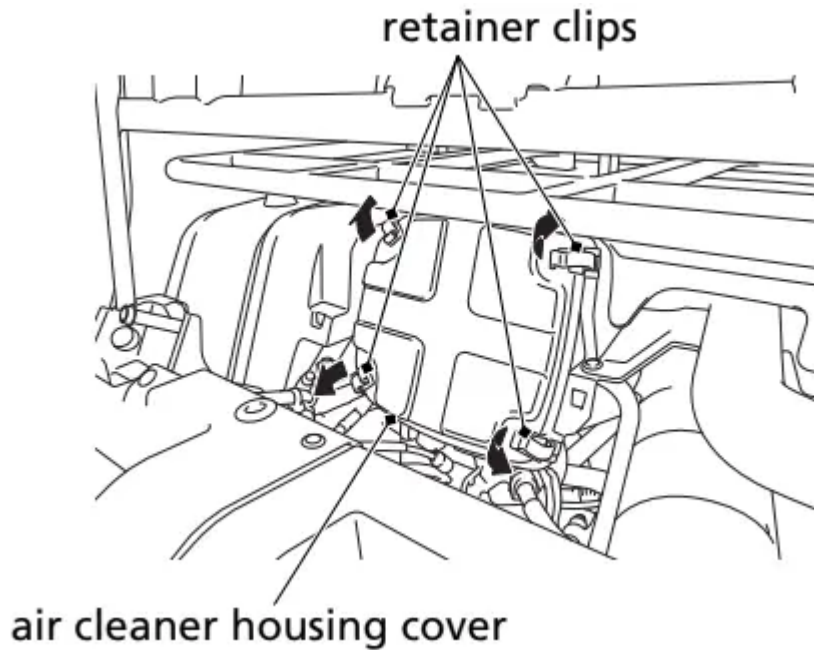

1. Remove the seat back and center rear panel
2. Unlatch the retainer clips.
3. Remove the air cleaner housing cover.
4. Remove the air cleaner holder.
5. Loosen the screw and remove the air cleaner assembly from the air cleaner housing.
6. Unscrew the clamp.
7. Remove the air cleaner from the air cleaner body.
8. Gently wash the air cleaner in clean, non-flammable (high flash point) solvent such as kerosene. Do not use gasoline. After cleaning, gently squeeze out the remaining solvent. Avoid twisting or wringing the air cleaner. This can tear the foam. Inspect for tears or cracks in the foam or seams of the air cleaner.
9. Replace the air cleaner if it is damaged.
10. Allow the air cleaner to dry thoroughly before applying oil. A wet air cleaner will not fully absorb the oil.
11. Pour clean Pro Honda Foam Filter Oil or an equivalent over the entire surface of the air cleaner. Use both hands to evenly spread the oil into the air cleaner. Gently squeeze out any excess oil. (To keep your hands dry, place the air cleaner in a clean plastic bag before spreading the oil into the air cleaner.)
12. Install the air cleaner on the air cleaner body.
13. Install the clamp.
14. Insert the air cleaner assembly into the air cleaner housing.

15. Fasten the screw.
16. Install the air cleaner holder.
17. Reassemble in the reverse order of removal.

UNDER CARGO CARRIER

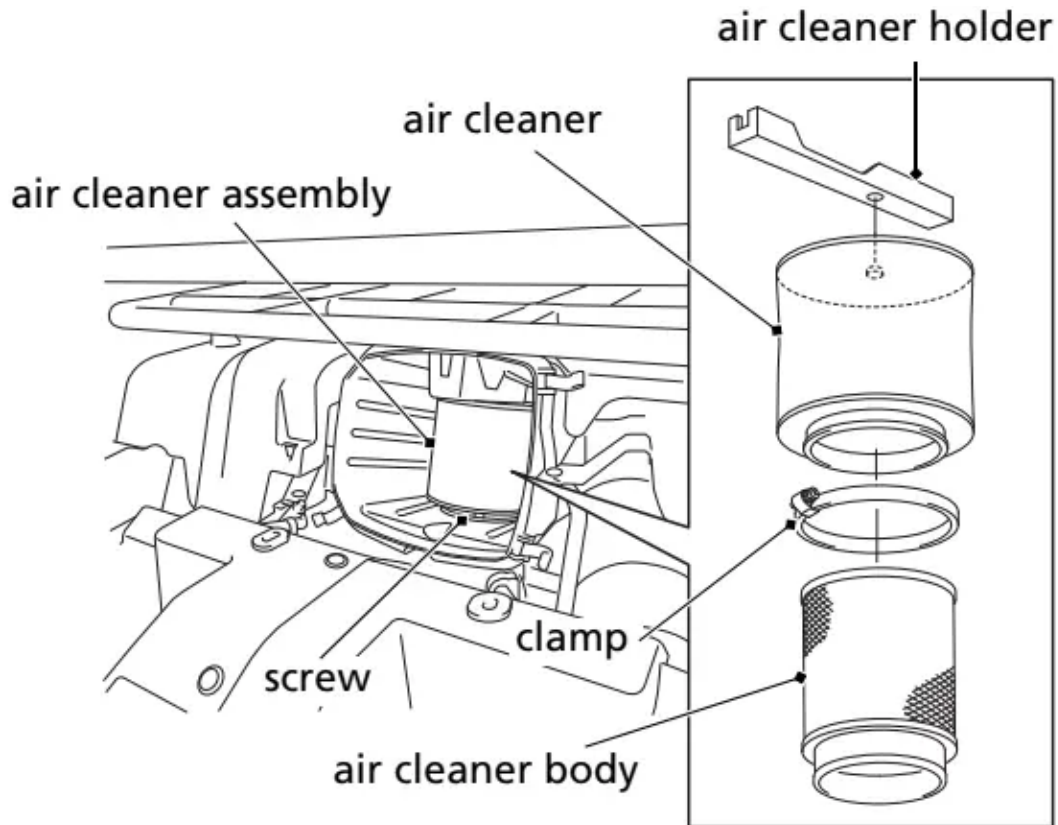

Air Cleaner Housing Drain Tube

SXS520M2

1. Remove the air cleaner housing drain tube by removing the clip under the air cleaner housing.
2. Drain the deposits.
3. Reinstall the air cleaner housing drain tube, securing it with the clip.

RIGHT REAR

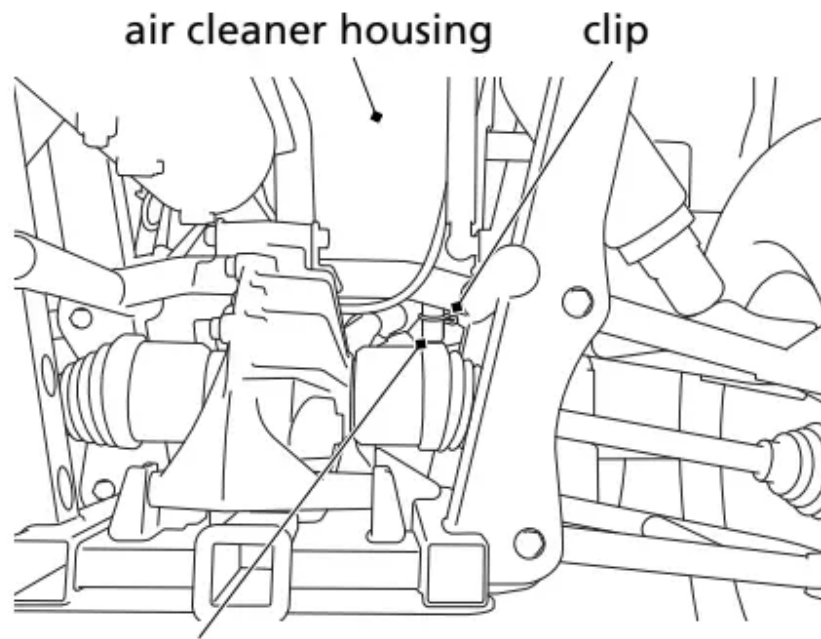

air cleaner housing drain tube

SXS500M2

1. Remove the air cleaner housing drain tube plug by removing the clip.
2. Drain the deposits.
3. Reinstall the air cleaner housing drain tube plug, securing it with the clip.

RIGHT REAR

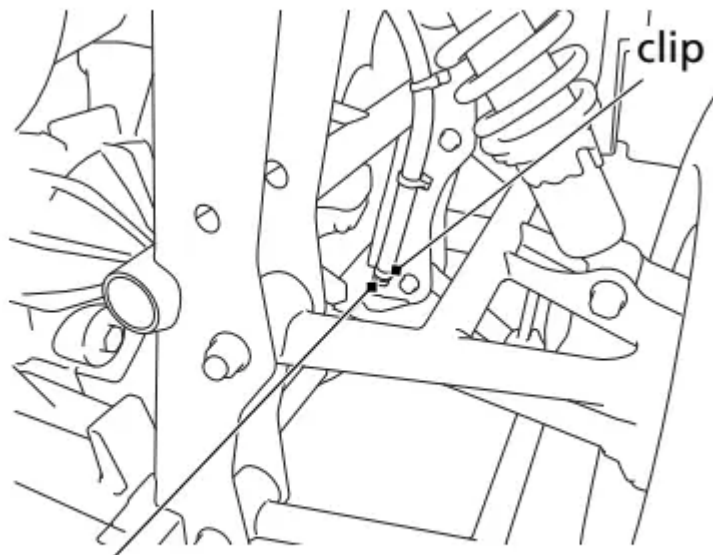

air cleaner housing drain tube plug



Brakes

Fluid Level Inspection

Check the fluid level on level ground.

1. Slide the brake fluid reservoir tank cap cover up a little to reveal the MAX level mark. Do not remove the brake fluid reservoir tank cap cover.

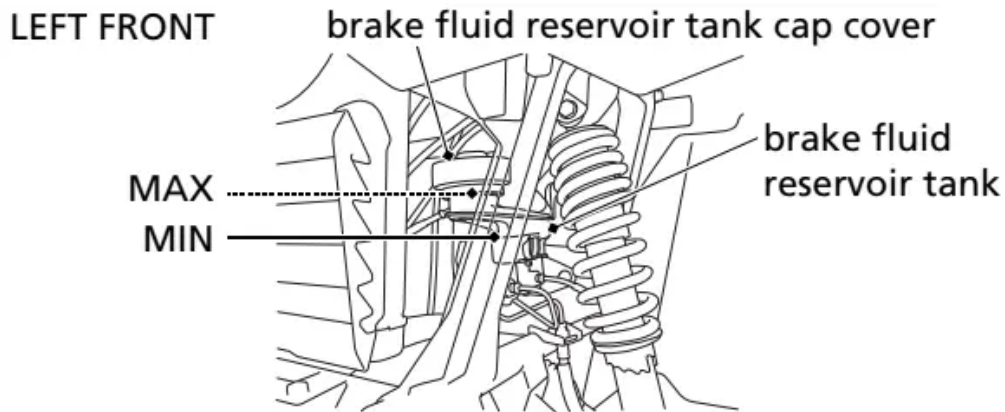

2. Return the brake fluid reservoir tank cap cover to its normal position.

Worn brake pads should be replaced. If the pads are not worn, have your brake system inspected for leaks.

- Wipe up spills immediately. Avoid contact with skin or eyes.
- If brake fluid comes in contact with your eyes, wash them out with clean water and immediately call a doctor.
- If brake fluid comes in contact with your skin, wash with clean water and, if necessary, call a doctor.

Brake Pedal Inspection

Check that the brake pedal moves smoothly and does not feel abnormally spongy.

Parking Brake Lever Freeplay

Inspection

Measure the freeplay of the parking brake.

Freeplay is measured from the lever fully disengaged (at stopper) to when lever is pulled up and resistance is felt in lever.

Parking brake lever freeplay is: **1 9/16 – 2 1/2 in (40 – 65 mm)**

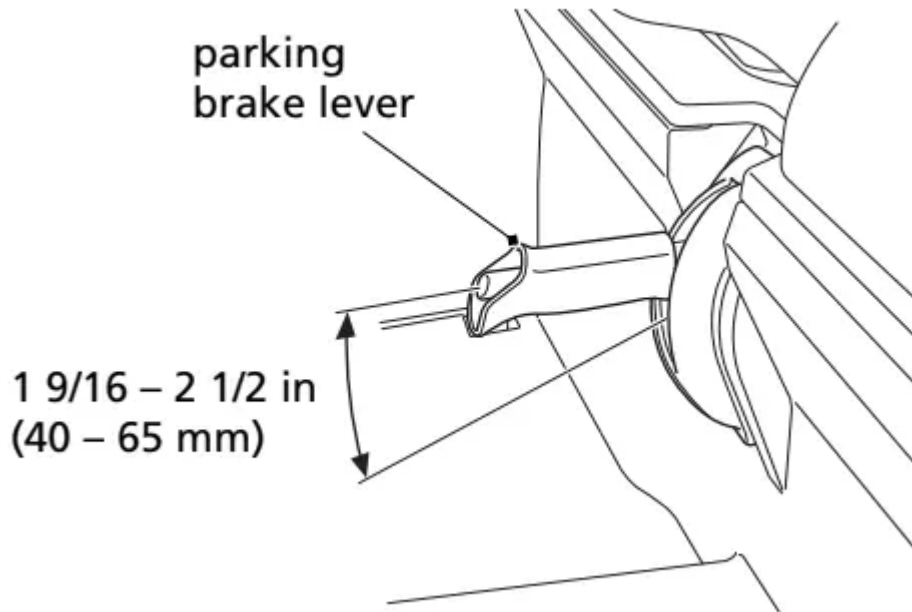

Brake Light Switch Adjustment

Periodically check the operation of the brake light switch. It is located under the front hood, just above -- and slightly behind -- the brake fluid reservoir.

The brake light should turn on just before the brake works.

Adjustment is done by holding the switch body and turning the adjusting nut. Turn the nut in direction (A) if the switch operates too late, and in direction (B) if the switch operates too soon.

UNDER FRONT HOOD

LEFT SIDE

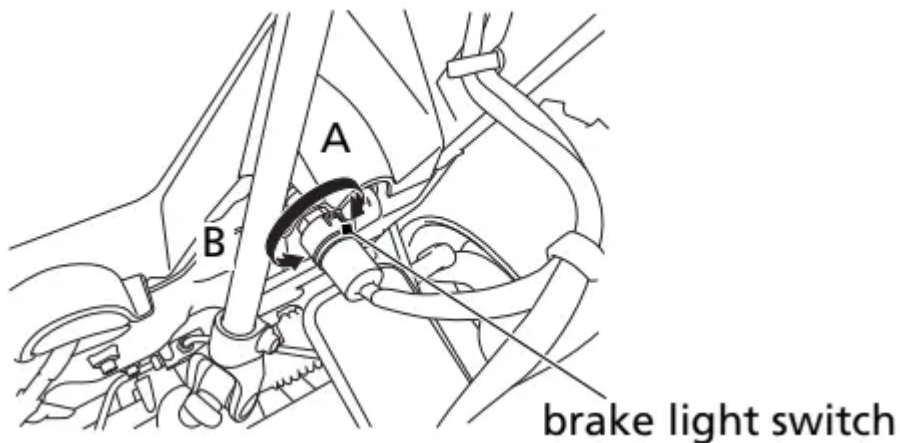

Tires

Inspection

Whenever you check the tire pressures, you should also look for:

- Bumps or bulges in the side of the tire or the tread. Replace any tire that has a bump or bulge.
- Cuts, slits, or cracks in the tires. Replace the tire if you can see fabric or cord.
- Nails or other foreign objects embedded in the side of the tire or tread.
- Excessive tread wear.

Also, if you hit a hard object or obstacle while driving, stop as soon as you safely can and carefully inspect the tires for damage.

Tread Wear

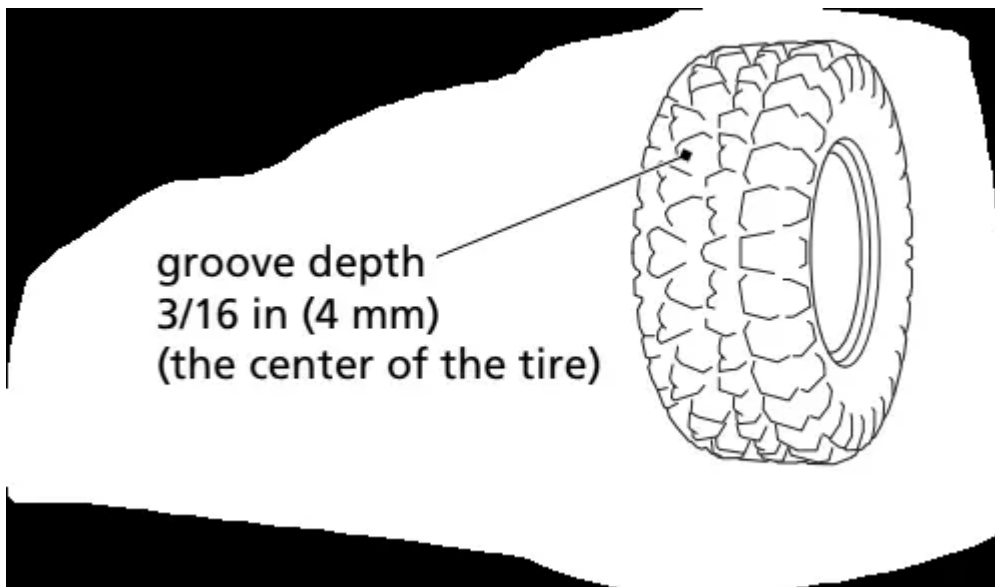

To check the condition of a tire tread, measure the groove depth in the center of the tire.

For best performance, you should replace a tire before the tread depth at the center reaches the following limits:

front	3/16 in (4 mm)
rear	3/16 in (4 mm)

SXS500M2

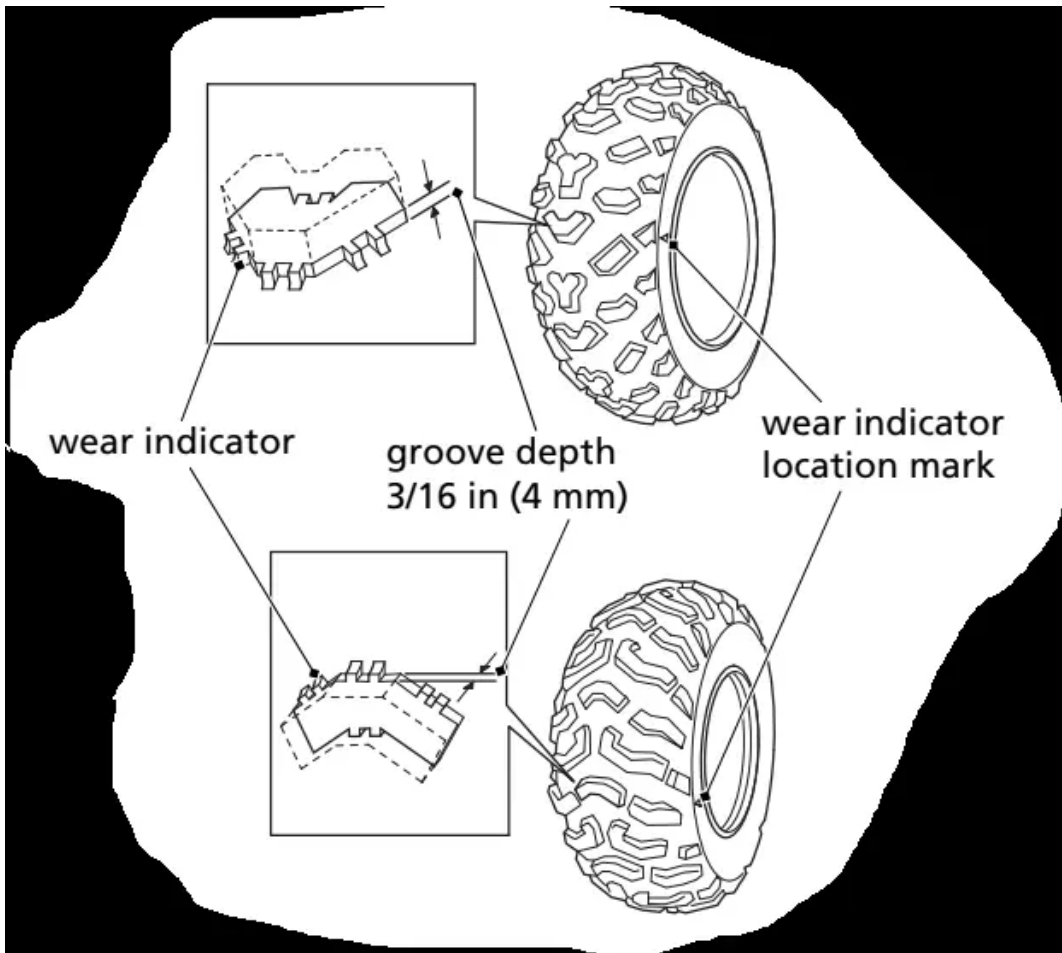

To check the condition of a tire tread, measure the groove depth in the center of the tire, or check the wear indicator.

For best performance, you should replace a tire before the tread depth at the center reaches the following limits:

front	3/16 in (4 mm)
rear	3/16 in (4 mm)

Tire Replacement

The recommended tires for your Honda SXS are:

SXS520M2

front	24X8.00-12 NHS Vee Rubber V-392
rear	24X10.00-12 NHS Vee Rubber V-392

SXS500M2

front	24X8.00-12 NHS MAXXIS M977H
rear	24X10.00-12 NHS MAXXIS M978H

Inspection

Check that the wheel nuts are tight and there are no cracks or deformation in the wheel.

**CHECK FOR CRACKS
OR DEFORMATION.**

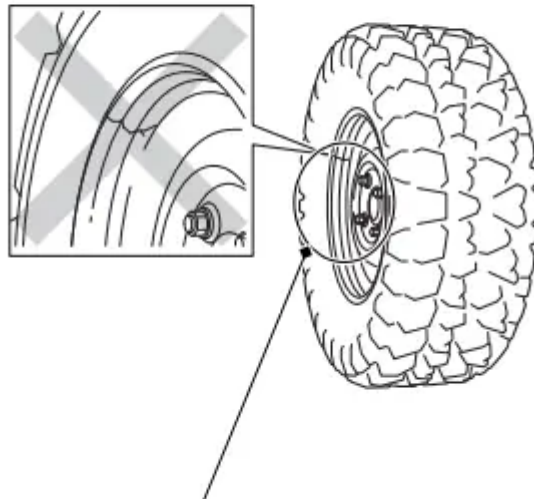

**CHECK THAT THE WHEEL NUTS
ARE TIGHT**

Driveshaft Boots

Check the boots for tears or traces of splattered grease.

If necessary, have your dealer replace them.

FRONT

SXS520M2 shown



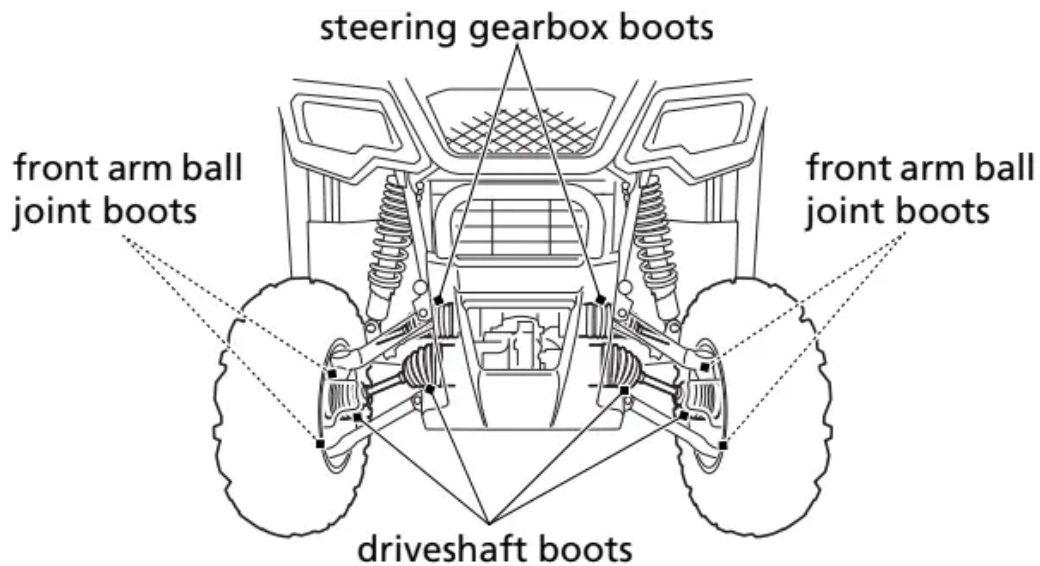

REAR

SXS520M2 shown

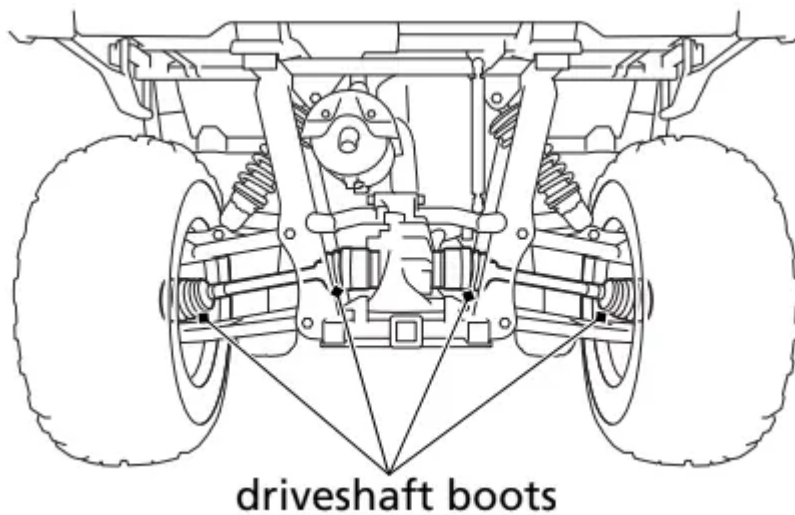

NOTICE Your battery is a maintenance-free type and can be permanently damaged if the cap strip is removed.

- Electrical accessories use current from the battery, some even when the ignition is OFF. Limited operation of your Honda SXS also allows the battery to discharge. If you have electrical accessories on your Honda SXS, or do not drive frequently, we recommend that you charge the battery frequently.
- If you do not expect to drive your Honda SXS for at least two weeks, we recommend you remove the battery, or at least disconnect the battery cables (negative cable first).

Battery

Removal

1. Make sure the ignition switch is OFF (O).
2. Remove the bolts and battery cover.
3. Release the ring and remove the rubber band.
4. Disconnect the negative (-) terminal lead from the battery first, then disconnect the positive (+) terminal lead.
5. Remove the battery from the battery box.
6. Charge the battery (see the following section), unless you have been driving regularly.
7. Store your battery in an easy-to-reach location off the floor, in an area protected from freezing temperature and direct sunlight.
8. Clean the battery box after removing the battery for storage. Dry the battery box.
9. Slow charge the battery once every 30 days.

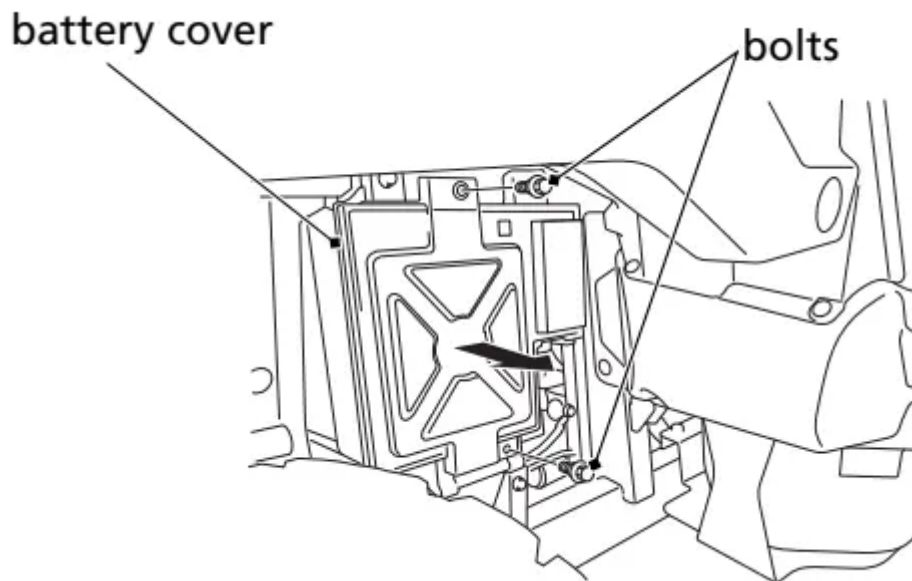

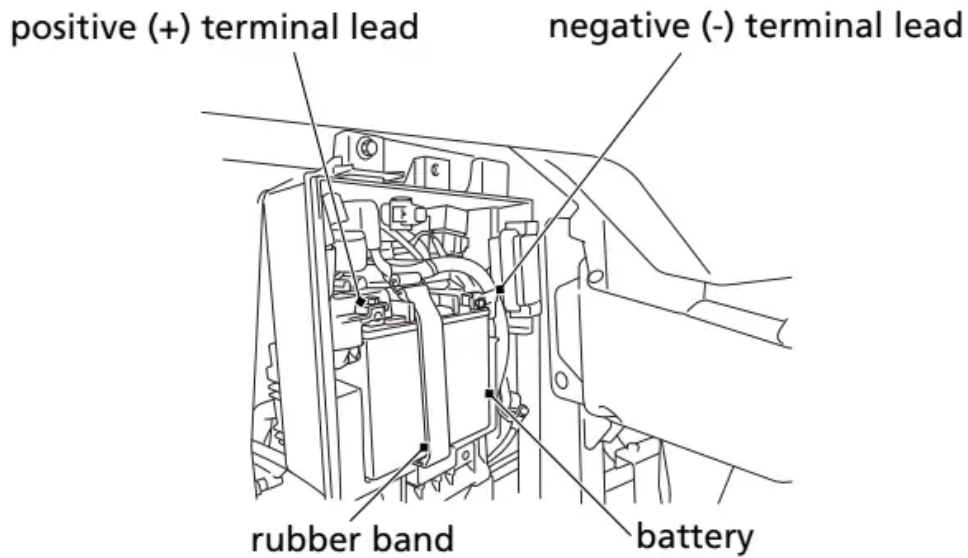

Installation

Reinstall in the reverse order of removal.

Be sure to connect the positive (+) terminal first, then the negative (-) terminal.

Make sure the clock is set to the proper time after the battery is reconnected

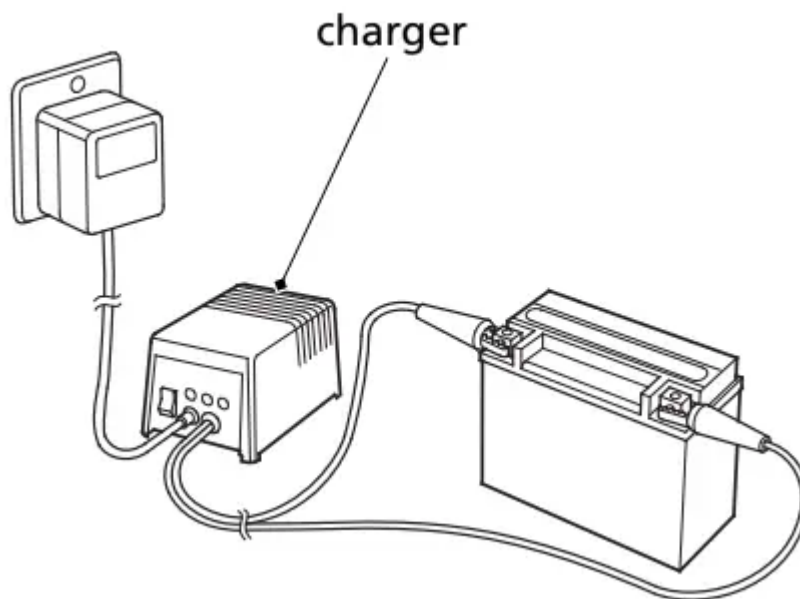

TROUBLESHOOTING

Engine Quits or Won't Start

Proper operation and maintenance can prevent starting and engine performance problems. In many cases, the cause of the problem may be a simple operational oversight.

If you have a problem starting the engine — or experience poor engine performance — the following information may help you. If you can't correct the problem, see your dealer. If your SXS won't start, listen as you turn the ignition key to the

START (II) position. If you don't hear the starter motor turning, refer to the Starter motor doesn't operate symptom. If you can hear the starter motor working normally, refer to the Starter motor works, but the engine won't start symptom.

SYMPTOM: Starter motor doesn't operate.	
POSSIBLE CAUSE	WHAT TO DO
transmission not in neutral	Shift into neutral or press on the brake pedal.
blown fuse	Replace with a new fuse of the same rating
battery lead loose	Tighten the battery lead.
low battery	Charge the battery. If charging doesn't help, see your dealer.
faulty starter motor	If all possible causes are negative, the starter motor may be faulty. See your dealer.

SYMPTOM: Starter motor works, but the engine won't start.	
POSSIBLE CAUSE	WHAT TO DO
out of fuel	Fill the fuel tank.
flooded engine	Starting the engine
loose or unconnected spark plug cap	Install the spark plug cap securely. If the engine still won't start, see your dealer.
loose battery cables	Tighten the battery terminal bolts.
weak battery	Charge the battery. If charging doesn't help, see your dealer.



SYMPTOM: Engine starts, but runs poorly.	
POSSIBLE CAUSE	WHAT TO DO
high coolant temperature	Check the high coolant temperature indicator.
runs erratically, misfires	May damage catalytic converter. See your dealer.
blubbers (rich fuel mixture)	See your dealer.
sooty exhaust (rich fuel mixture)	See your dealer.
detonates or pings under load	If applicable, switch to the recommended octane gasoline or change your brand of gasoline. If the problem persists, see your dealer.
afterfires (backfires)	May damage catalytic. See your dealer.
pre-ignition (runs on after ignition switched OFF)	May damage catalytic converter. See your dealer.

SYMPTOM: Engine starts, but runs poorly or dies when hot.	
POSSIBLE CAUSE	WHAT TO DO
poor or inadequate fuel flow due to clogged fuel filter	See your dealer. (ensure clean fuel supply)

Shift Paddles Do Not Function

If one or both shift paddles do not function, see the following instructions. If proper function cannot be restored, see your dealer.

1. If the engine is running, stop the SXS.
2. Turn the ignition switch to the "OFF" (O) position.
3. After the engine stops, turn the ignition switch to the "ON" (I) position.
4. Pull the upshift paddle then the downshift paddle and check that they are functioning.
5. If both paddles are functioning, shift into neutral and restart the engine.

Transmission Is Not Functioning Properly

When the transmission is not shifting properly, the gear position indicator will show “–” and blink or the gear position (“1”, “2”, “N” or “R”) is blinking.

See your dealer to check and restore the transmission.

If the gear position indicator shows “–” and blink or the gear position (“1”, “2”, “3”, “4”, “5”, “N” or “R”) is blinking while driving, perform the following:

1. Stop the SXS.
2. Turn the ignition switch to the OFF (O) position.
3. After the engine stops, turn the ignition switch to the ON (I) position.
4. Check the gear position indicator.

If these efforts do not restore proper operation, have your SXS inspected by your dealer.

When the “–” is blinking or the gear position (“1”, “2”, “3”, “4”, “N” or “R”) is blinking in the gear position indicator:

Restart the engine; drive the SXS by operating the shift paddles to a location where it can be loaded and transported to your dealer. We recommend that you drive slowly in 1st gear.

When the display on the gear position indicator returns to normal:

You may drive on the SXS as usual after restarting the engine.

However, we urge you to have your SXS inspected by your dealer.

Emergency Gear Selection & Operation

If the shift paddles do not operate, use the following procedure to manually select a gear so you may drive the vehicle to a location where it can be loaded and transported to a dealer.

1. Make sure unit is on level ground.
2. Turn the ignition switch to the “ON” (I) position.
3. Remove the seat bottom.
4. Gear change tool is located under the seat bottom on left side.
5. Check the neutral indicator:
 - If the transmission is in neutral, go to step 6.
 - If the transmission is not in neutral, fold open the rubber dust cover and use the gear change tool to shift to neutral so you will be able to start the engine.
6. Apply the parking brake.
7. Turn the key to start the engine.
8. Select the gear you want. For running on level ground: 3rd or 4th gear position. For mountain roads: 2nd or 3rd gear.

9. Return the gear change tool to its holder under the seat bottom.
10. Install the rubber dust cover.
11. Install the seat bottom.
12. Get into the SXS. Drive it at a safe speed to a place where it can be repaired or serviced.

How to Shift Gears Manually:

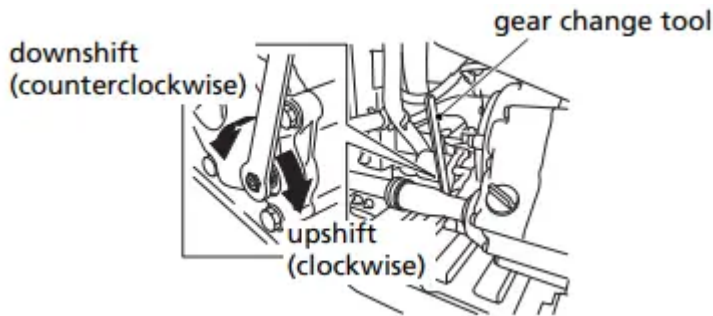

- With the SXS unoccupied, align the hexagonal hole of the gear change tool with the hexagonal end of the secondary spindle which is located on the front crankcase.
- To downshift, turn the gear change tool counterclockwise.
- To upshift, turn the gear change tool clockwise.
- If the transmission does not shift, rock the vehicle back and forth and try again. If the transmission still will not shift, invert the gear change tool and try again.
- Return the gear change tool to its under seat bottom on the left side.

Do not attempt to shift gears manually using the gear change tool while driving.

If the transmission is shifted manually when the electric shift system is functioning, the system will shutdown automatically and the shift paddles will not operate. To reactivate the system, turn the ignition switch to the “OFF” (O) position, then turn it back to the “ON” (I) position.

Flat Tire

- How you handle a flat tire on the trail depends on how serious the tire damage is, and what tools and supplies you have with you.
- If you have a slow leak or a minor puncture, use the plug method to make a temporary repair. (The plug method is applied from the outside of the tire and is the same as that for conventional tubeless tires.)
- A plug-type repair kit, available at most auto parts stores or service stations, provides a plug, an installation tool, tire cement, and an instruction sheet. Follow the instructions provided with the repair kit to make a temporary repair.
- As soon as possible, have the tire permanently repaired by your dealer.
- Any tire that cannot be repaired should be replaced.



- Whenever the Honda SXS is to be operated far from service facilities or available transportation, we recommend that you carry a tire pump and a repair kit with the vehicle.
- If the leak is more serious, or a temporary repair doesn't hold, the tire must be replaced.
- If you are unable to repair a flat tire on the trail, you will need to send for help. We strongly recommend that you do not try to drive with a flat tire. The Honda SXS will be hard to handle, and if the tire comes off the rim, it may lock up the wheel and cause you to crash or overturn.

Emergency Wheel Removal/Installation

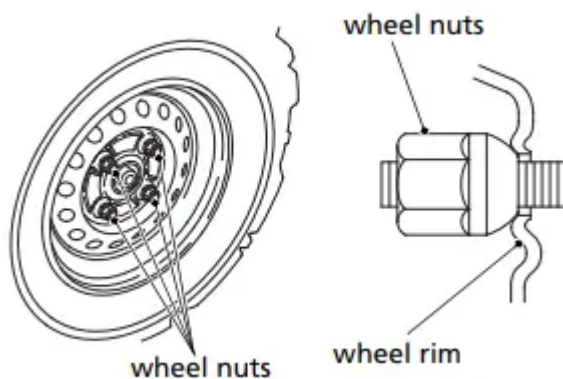

Removal

1. Park your Honda SXS on a firm, level surface.
 2. Loosen — but do not remove — the wheel nuts.
 3. Raise the front (or rear) wheels off the ground.
 4. Remove the wheel nuts.
 5. Remove the wheel.
- Avoid getting grease, oil, or dirt on the disc or pad surfaces when removing and installing each wheel. Any contamination can cause poor brake performance or rapid pad wear after reassembly.

Installation

1. Thoroughly clean hub and wheel.
2. Position the wheel.
3. Position the wheel nuts so that the tapered sides face the wheel rim.
4. Hand-tighten the wheel nuts on the wheel, then lower the Honda SXS to the ground before tightening the nuts in a crisscross (rather than circular) pattern to the specified torque: lbf·ft (133 N·m, 13.6 kgf·m)

If a torque wrench was not used for installation, see your dealer as soon as possible to verify proper assembly. Improper assembly may lead to loss of control and braking capability.

High Coolant Temperature Indicator Lights

Normally, the high coolant temperature indicator will only light momentarily when you turn the ignition ON (I). Occasionally, it may flicker at or near idling speed.

High coolant temperature may be caused by restriction of air flow to the radiator (such as mud caked on the radiator), extended idling, an oil leak, a coolant leak, a low oil level, a low coolant level, or extended operation under adverse conditions.

If the all sections of the coolant temperature gauge including segment H and high coolant temperature indicator are on while you're driving, don't ignore it. Pull safely to a stop. Stop the engine as soon as it's safe to do so, and let it cool.

NOTICE

Continuing to drive with high coolant temperature or an overheated engine can cause serious engine damage.

- A steaming engine indicates a coolant leak. Shut the engine off and wait until the steaming stops. Look for a leak, but don't touch the engine or radiator system. Let everything cool off first.
- Check for any restriction of air flow to the radiator.
- If there's no obvious problem, leave the engine on so the fan and coolant circulating system can continue working. Monitor the coolant temperature gauge and high coolant temperature indicator. The coolant temperature gauge and indicator may return to normal after a brief stop with no load on the engine.
- Check the radiator fan.
- If the fan is not working, turn the engine off. Open the fuse box and check the radiator fan fuse. If the fuse is blown, replace it with the proper (same rating) spare fuse. Start the engine. If all sections of the coolant temperature gauge including segment H and high coolant temperature indicator are stay on, turn the engine off.
- If the radiator fan is working, visually check the coolant level in the reserve tank, located under the front hood. It isn't necessary to touch the radiator system.
- If the reserve tank is low or empty, don't drive without adding coolant. After adding coolant, turn the engine on and check the coolant temperature gauge and high coolant temperature indicator.
- If the indicator doesn't turn off, do not drive. The engine needs repair.
- Transport your Honda SXS to a dealer.
- If the temperature drops to normal, check the coolant level. If it has gone down, add more coolant.

- Check for an oil leak.
- Check the oil level. If necessary, add the recommended oil to the upper level mark. If you must leave your Honda SXS to get oil, secure it as much as possible.
- Start the engine, and check that the coolant temperature gauge and high coolant temperature indicator are normal.

If the coolant temperature gauge and indicator return to normal, resume driving. If there is a leak, do not drive the SXS until the leak is repaired by your dealer.

If there's a mild coolant leak, you can drive for a while, carefully watching the coolant temperature gauge and indicator. Be prepared to stop and add more coolant or water. If the leak is bad, transport your Honda SXS to your dealer.

Fuse Blows

All of the electrical circuits on your Honda SXS have fuses to protect them from damage caused by excess current flow (short circuit or overload).

If something electrical on your Honda SXS stops working, the first thing you should check for is a blown fuse.

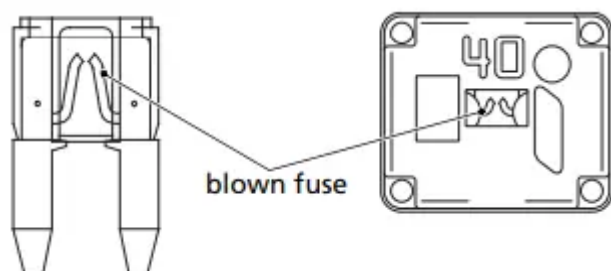

Check all the fuses before looking elsewhere for another possible cause of the problem. Replace any blown fuses and check component operation.

The main fuse and the circuit fuses are located in the battery box under the right side of rear fender.

Recommended Fuses

main fuse	40 A
circuit fuses	30 A, 15 A x 4, 10 A x 2

Main Fuse Access

1. To prevent an accidental short circuit, turn the ignition switch OFF (O) before checking or replacing the fuses.
2. To access the main fuse, remove the battery cover.

3. Remove the fuse cover.
4. Pull the main fuse out. If it is blown, install the spare main fuse. Spare main fuse is located in reverse side of the battery cover.
5. Install the fuse cover.
6. To access the circuit fuse, remove the fuse box cover.
7. To check or replace a circuit fuse, pull the old fuse out. If the fuse is blown, replace it with a spare fuse of the same rating. Spare fuses are located in the fuse box
8. Install the fuse box cover
9. Install the battery cover.

RIGHT REAR

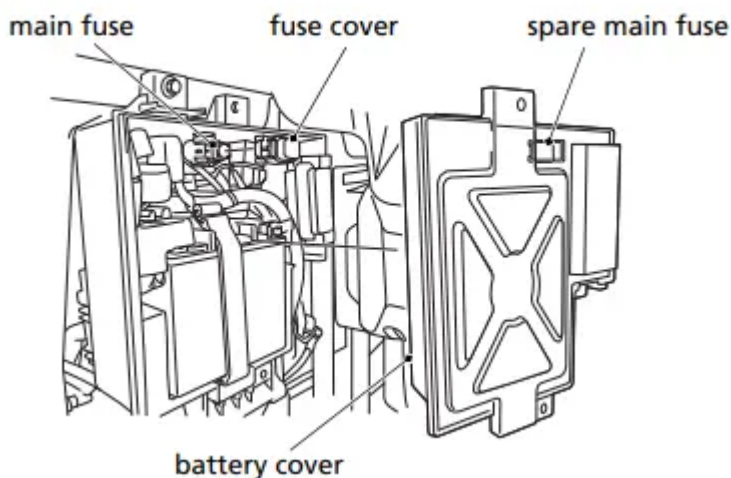

NOTICE

If you do not have a spare fuse and you cannot drive the Honda SXS without fixing the problem, take a fuse of the same rating or a lower rating from one of the other circuits that you can do without temporarily.

If you replace a blown fuse with a spare fuse that has a lower rating, replace the fuse with the correct rating as soon as you can. Also remember to replace any spare fuses that were installed.

If the replacement fuse of the same rating burns out in a short time, there is probably a serious electrical problem on your Honda SXS. Leave the blown fuse in that circuit and have your Honda SXS checked by your dealer.

Crash

Personal safety is your first priority after a crash. If you or anyone else has been injured, take time to assess the severity of the injuries and whether it is safe to continue driving. If you cannot drive safely, send someone for help. Do not drive if you will risk further injury.

If you decide that you are capable of driving your SXS safely, first evaluate the condition of your SXS. If the engine is still running, turn it off and look it over carefully; inspect it for fluid leaks, check

the tightness of critical nuts and bolts securing such parts as the steering wheel, control levers, brakes, and wheels.

If there is minor damage, or you are unsure about possible damage but decide to try driving the Honda SXS back to your base, drive slowly and cautiously.

Sometimes, crash damage is hidden or not immediately apparent. When you get home, thoroughly check your Honda SXS and correct any problems you find. Also, be sure to have your dealer check the frame, suspension, seat belts, and occupant protective structure after any serious crash.

Lose Your Key

Be sure to record your key number. Store the spare key and recorded key number in a safe location. You'll need this number to have a duplicate key made.

If you lose your key and aren't carrying a duplicate, either get your spare or have one made. If you don't know your key number, call the dealer where you purchased your Honda SXS. They may have it listed in their records. If they don't, transport your Honda SXS to them or the nearest dealer. The dealer will probably have to remove the ignition switch assembly to find the key number so they can make a key for you.

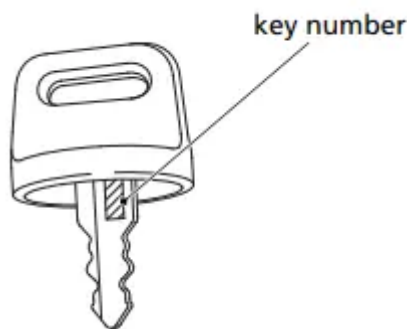

Low Battery

If the battery is low, the starter motor doesn't operate or works poorly, and you can't start the engine.

Jump starting your Honda SXS should be avoided. Instead, the battery should be removed and recharged.

If you can't charge the battery or it appears unable to hold a charge, contact your dealer.

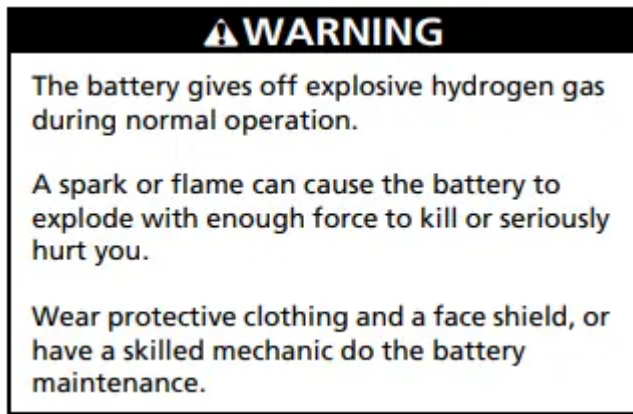

WARNING: Battery posts, terminals and related accessories contain lead and lead compounds. **Wash your hands after handling.**

However, when there is no option other than jump starting, follow the instructions given below.

NOTICE

If a battery sits in extreme cold, the electrolyte inside can freeze. Attempting to jump start with a frozen battery can cause it to rupture.

Use a battery that is the same as the one in the vehicle or an equivalent.

1. To prevent an accidental short circuit, turn the ignition switch OFF (O).
2. Remove the battery cover.
3. Using a fully charged 12-volt battery, connect the positive (+) side of the jumper cable to the charged battery, and connect the positive (+) side on the other end of the jumper cable to the positive (+) terminal of vehicle battery.
4. Connect the negative (-) side of the jumper cable to the charged battery, and connect the negative (-) side on the other end of the jumper cable to the rear final gear case (SXS520M2) or the upper muffler cover (SXS500M2).
5. After starting the engine, remove the negative (-) sides of the jumper cable from the vehicle and the battery. Then remove the positive (+) sides of the jumper cable from the vehicle battery and the charged battery.
6. Install the battery cover.
7. Do not let the positive (+) side of the jumper cable touch on the negative (-) terminal.
8. If the jumper cable is connected to the battery with the polarity reversed, the battery can explode or the electrical system will be seriously damaged

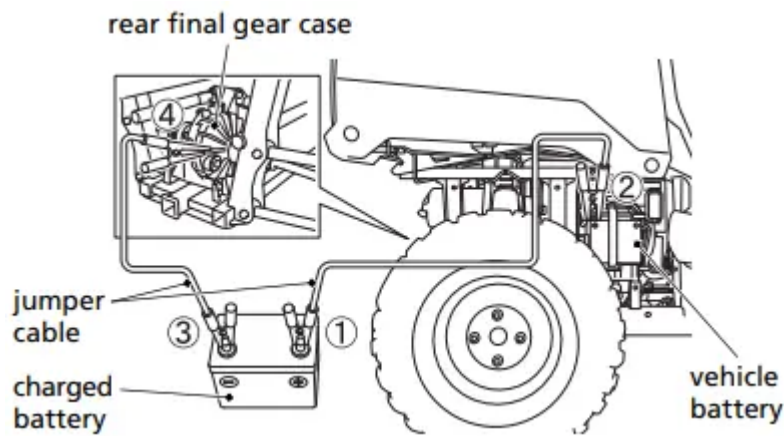

Component Fails

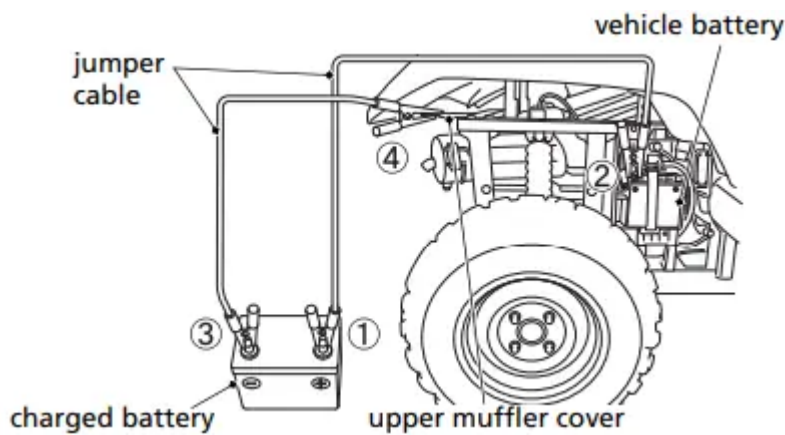

The brake lines, control cables, and other components can be damaged as you drive in dense brush or over rocky terrain. Making a trailside repair depends on how serious the damage is and what tools and supplies you have with you.

- If any component in the brake system is damaged, you may have reduced or limited stopping power. If you decide to continue driving back to your base, do so cautiously and at a very low speed.
- If you damage the accelerator cable or other critical component, your Honda SXS may be unsafe to drive. Carefully assess the damage and make any repairs that you can. But if there is any doubt, it's best to be conservative and safe.

Vehicle Speed Does Not Exceed 15 mph (24 km/h)

- If the driver's side seat belt is not latched properly, the maximum vehicle speed will be limited to no more than 15 mph (24 km/h) by the seat belt speed limiting system.
- Also the seat belt indicator and speedometer digits blink.
- Make sure that the driver's side seat belt is latched properly.

Warning

This content is compiled from multiple sources and is provided for reference purposes only. It may not be complete or fully applicable to all situations. If you are unable to resolve your issue, please contact the product manufacturer or an authorized service provider for official support.

Document generated by [ManualsFile](#)

