

Parts of your oven

1. Door Release Button

Press to open the door. Opening the door during cooking will stop the cooking process without cancelling the programme. Cooking resumes after the door is closed and Start is pressed. It is quite safe to open the door at any time during a cooking programme and there is no risk of microwave exposure.

2. Oven window

3. Air vents

4. Microwave feed guide (Do not remove.)

5. External air vents

6. Control panel

7. Power supply cord

8. Plug

9. Glass tray

10. Roller ring

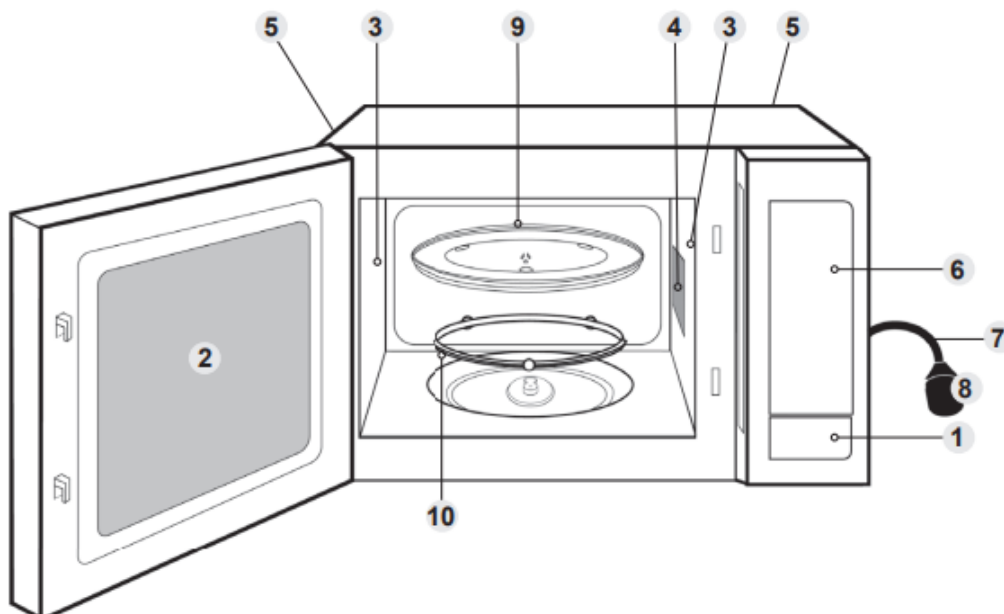

Control panel

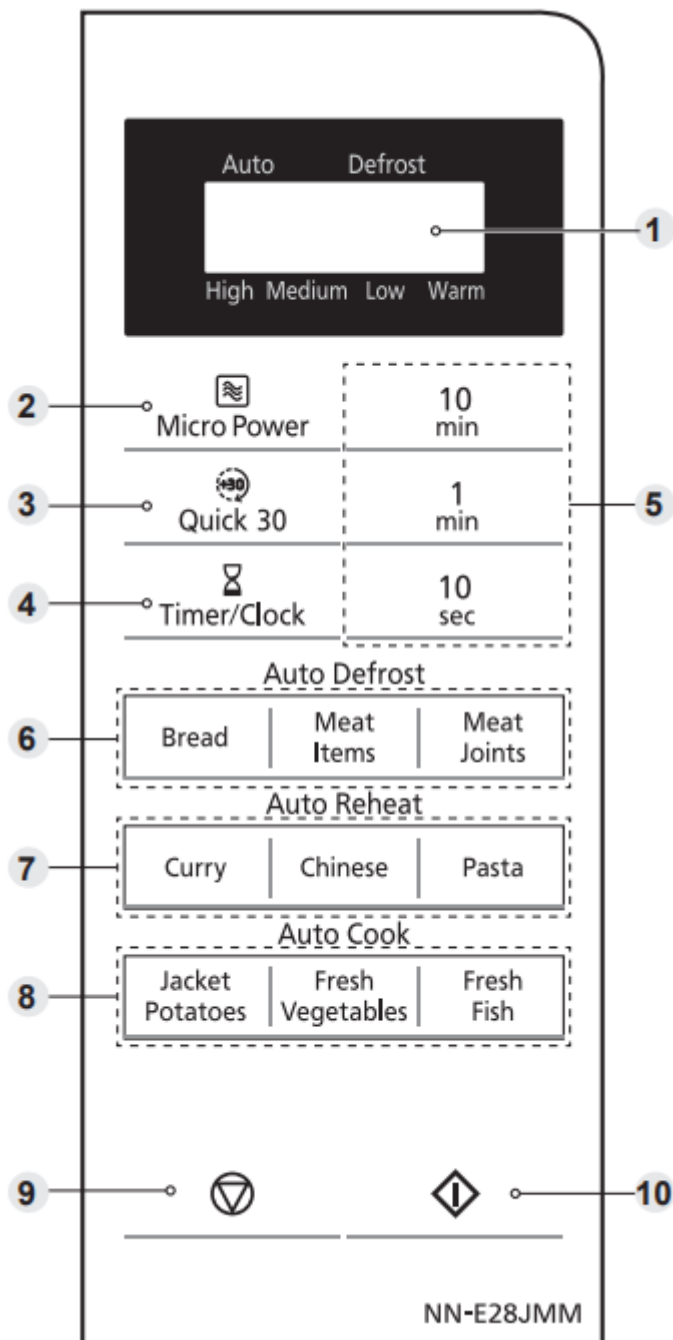

- Your control panel may have differences in appearance, but the words on the pads and functionality will be the same.

1 Display window

2 Micro Power pad

3 Quick 30 pad

4 Timer / Clock pad

5 Time pads

6 Auto Defrost pads

7 Auto Reheat pads

8 Auto Cook pads

9 Stop / Reset pad:

Before Cooking: One press clears your instructions.

During Cooking: One press temporarily stops the cooking process. Another press cancels all your instructions and a dot or the time of day will appear in the display.

10 Start pad

One press allows oven to begin functioning. If door is opened or Stop/Reset is pressed once during oven operation, Start must be pressed again to restart oven.

Beep sound

When a pad is pressed correctly a beep will be heard. If a pad is pressed and no beep is heard, the unit has not or cannot accept the instruction. The oven will beep twice between programmed stages. At the end of any complete programme, the oven will beep 5 times and "End" will be displayed.

Note If Start is not pressed for 6 minutes after cooking programme setting, the oven will automatically cancel the cooking programme. The display will revert back to clock or colon.

Setting the clock

When the oven is first plugged in, "88.88" appears in display.

Example: To set 11:25am

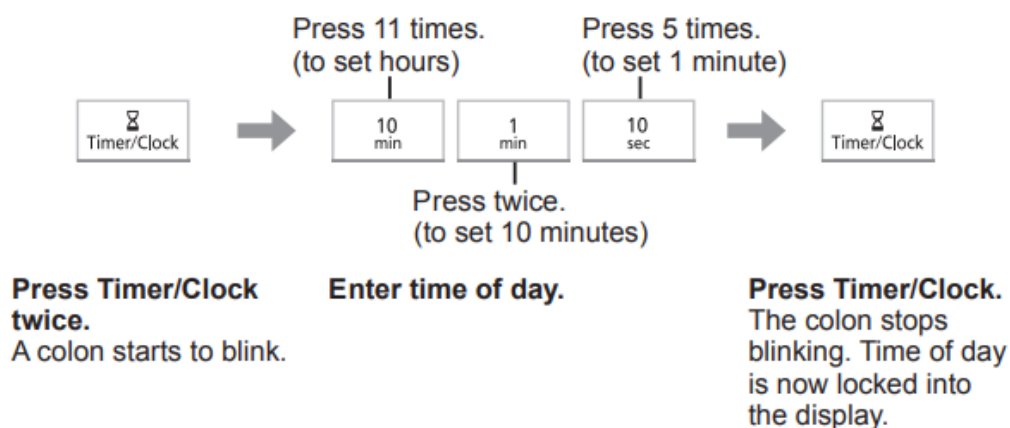

Notes

1. To reset time of day, repeat step 1 through to step 3, as above.
2. The clock will keep the time of day as long as the oven is plugged in and electricity is supplied.

3. This is a 24 hour clock, ie 2 pm = 14:00 not 2:00.

Child safety lock

This feature will make the oven controls inoperable; however, the door can be opened. Child Lock can be set when the display shows a dot or the time.

To Set:



Press Start 3 times in 10 seconds. The time of day will disappear. Actual time will not be lost. 'L ---' is indicated in the display.

To Cancel:



Press Stop/Reset 3 times in 10 seconds. The time of day will reappear in the display.

Microwave cooking and defrosting

The glass tray must always be in position when using the oven.

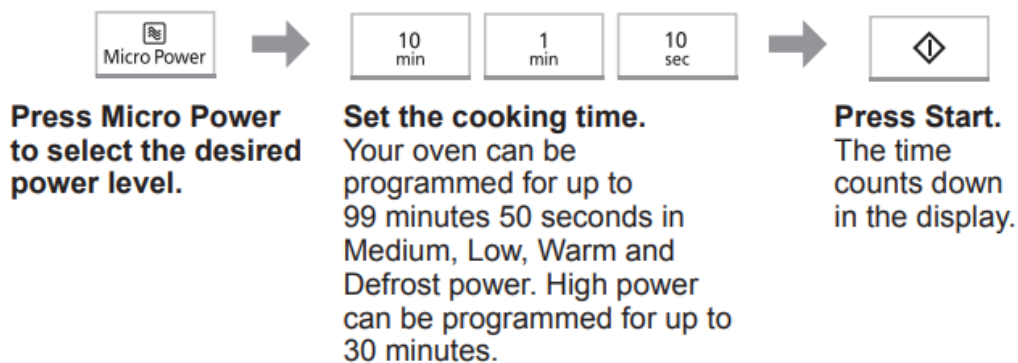

Press	Power Level	
once	High	800 W
twice	Defrost	270 W
3 times	Medium	700 W
4 times	Low	520 W
5 times	Warm	200 W

Notes

1. The oven will automatically work on High microwave power if a cooking time is entered without the power level previously being selected.
2. While cooking, the glass tray may vibrate. This will not affect cooking performance.
3. For MULTI-STAGE COOKING, refer to page 17.
4. STANDING TIME can be programmed after microwave power and time setting.
5. DO NOT use microwave only with any metal accessory in the oven.
6. Always check the food during defrosting by opening the door then restarting. It is not necessary to cover food during defrosting. To ensure an even result, stir, turn or separate several times during defrosting. For large joints and poultry, turn halfway through defrosting and protect ends and tips with foil.

Multi-stage cooking

This feature allows you to programme up to 3 stages of cooking continuously.

Example: To continually set High power (800 W) for 2 minutes, Medium power (700 W) for 3 minutes and Warm power (200 W) for 2 minutes.

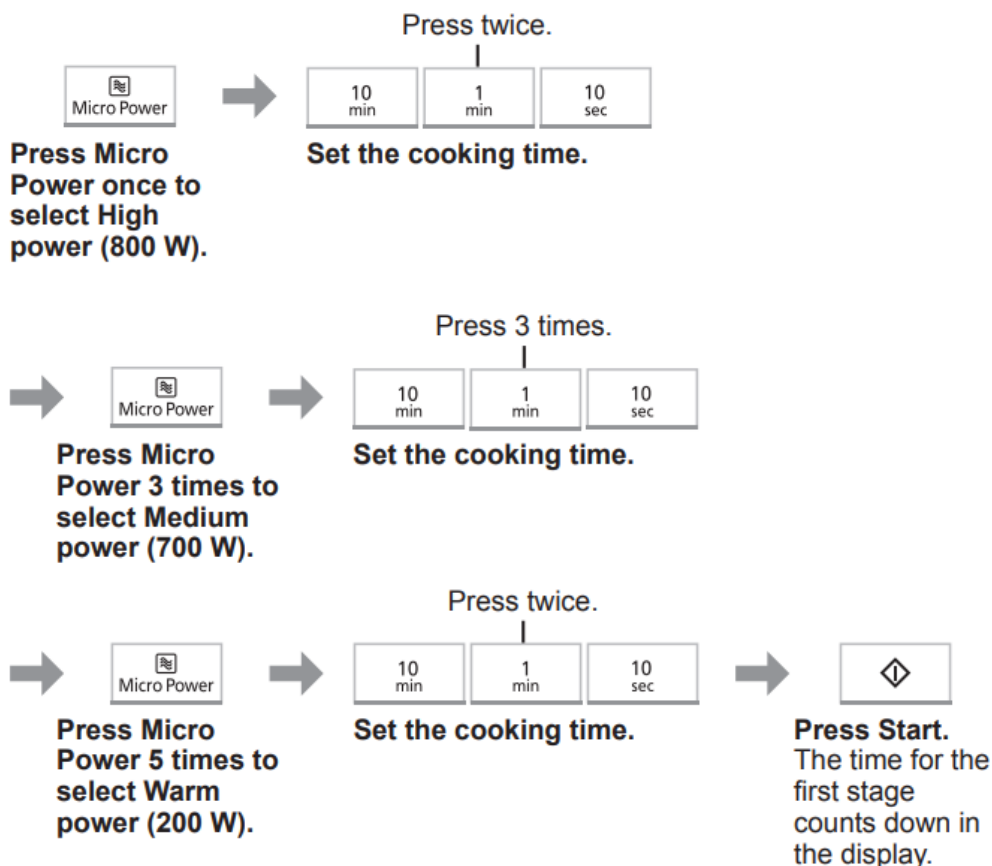

Notes

1. AUTO PROGRAMMES cannot be used with MULTI-STAGE COOKING.
2. When operating, 2 beeps will sound between each stage, and 5 beeps will sound after all stages have finished.

Quick 30 feature

This feature allows you to set cooking time in 30 seconds increments up to 5 minutes at High MICROWAVE power (800 W). It is only available for MICROWAVE.

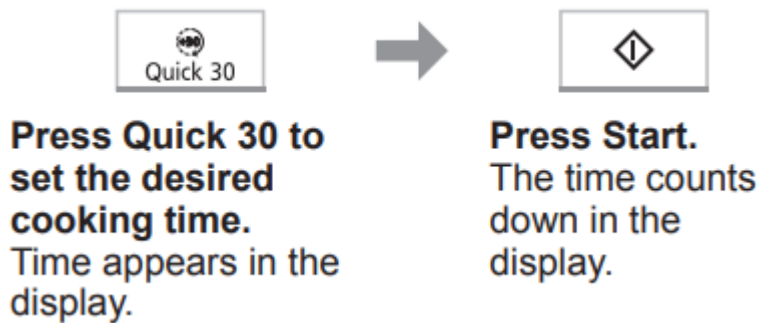

Note If desired, you can use other power levels. Select the desired power level before pressing Quick 30.

Using the timer

This feature operates as a KITCHEN TIMER or allows you to programme the STANDING TIME/DELAY START.

Kitchen timer

Example: To count 5 minutes.

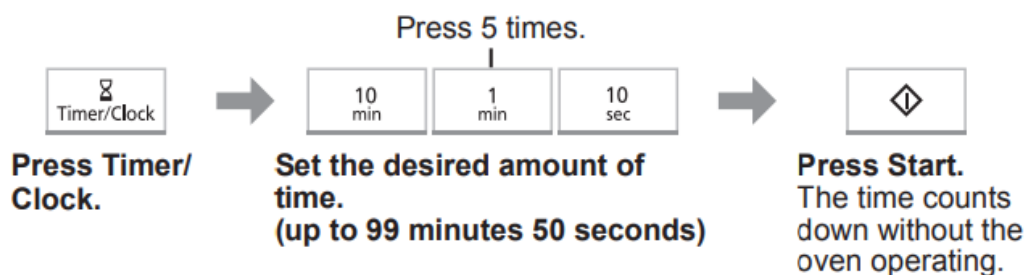

Standing time

Example: To stand for 5 minutes after cooking at Medium MICROWAVE power (700 W) for 3 minutes.

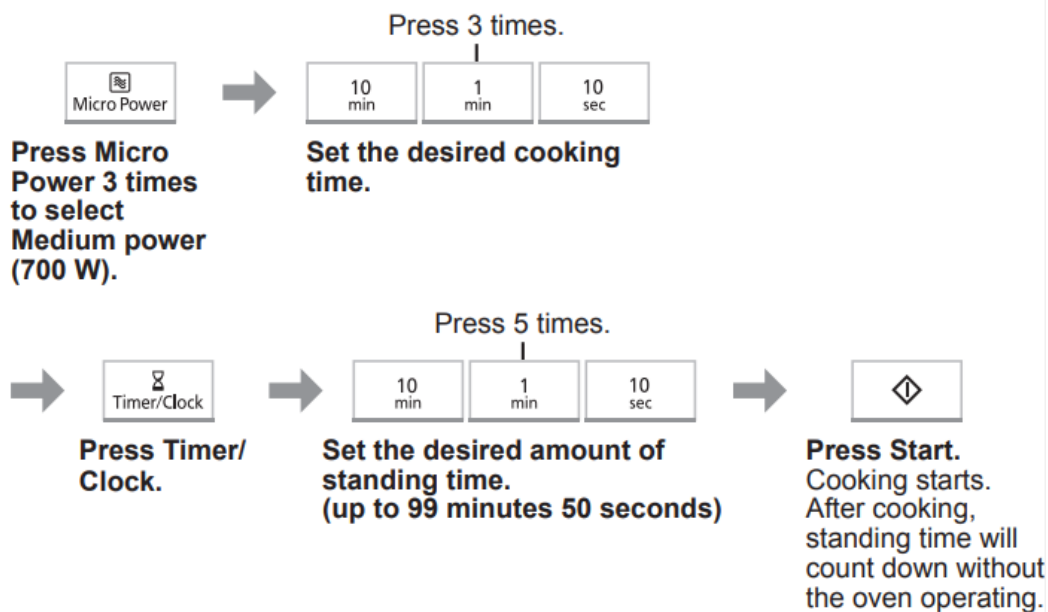

Delay start

Example: To start cooking at Medium MICROWAVE power (700 W) for 3 minutes after 5 minutes of standing time.

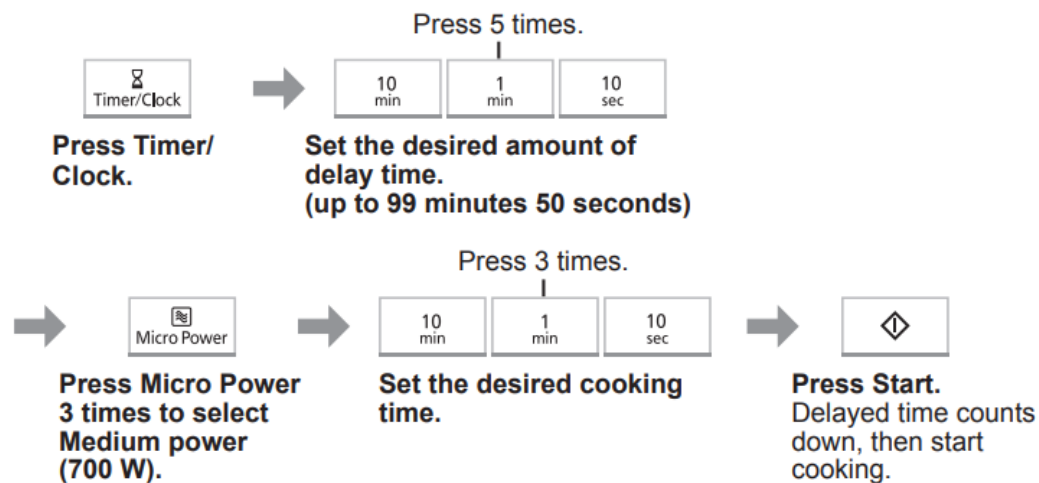

Notes

1. MULTI-STAGE COOKING can be programmed including STANDING TIME and DELAY START.
2. Even if the oven door is opened during KITCHEN TIMER, STANDING TIME or DELAY START, the time in the display window will continue to count down.
3. STANDING TIME/DELAY START cannot be programmed before/after any AUTO PROGRAMME.

Auto programmes

With this feature you can defrost/cook food according to the weight. Select the category and set the weight of the food. The weight is programmed in grams. The oven determines MICROWAVE power level, and then cooking time automatically. Do not include the weight of any added water or the container weight.



Notes

1. The AUTO PROGRAMMES must ONLY be used for foods described.
2. Only defrost/cook foods within the weight ranges described.
3. Always weigh the food rather than relying on the package information.
4. Most foods benefit from STANDING TIME. After cooking with an AUTO PROGRAMME, allow heat to continue conducting to the centre.

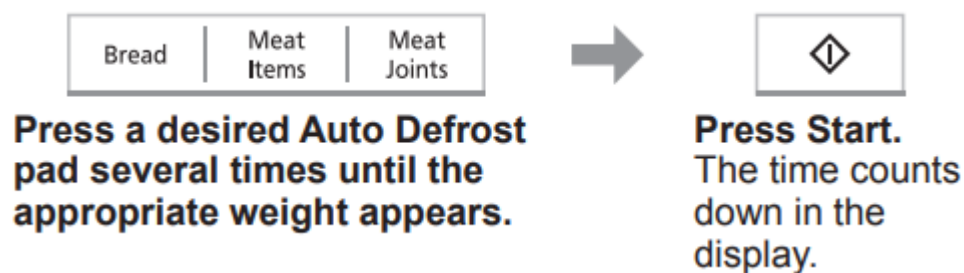
Auto defrost



Note The shape and size of the food will determine the maximum weight the oven can accommodate.

Programme	Instructions
<div data-bbox="344 315 424 360" style="border: 1px solid black; padding: 2px; width: fit-content; margin: 0 auto;">Bread</div>	<p>Weight: 100-600 g</p> <p>Accessories: </p> <p>For small items which are required for immediate use, they may feel warm straight after defrosting. Loaves can also be defrosted on this programme but these will require standing time to allow the centre to thaw out. Standing time can be shortened if slices are separated and buns and loaves cut in half. Items should be turned halfway during defrosting. THIS PROGRAMME IS NOT SUITABLE FOR CREAM CAKES OR DESSERTS e.g. cheesecake.</p> <p>See "Defrosting charts" for standing time.</p>
<div data-bbox="344 887 416 927" style="border: 1px solid black; padding: 2px; width: fit-content; margin: 0 auto;">Meat Items</div> <p>(mince/chops/ chicken portions)</p>	<p>Weight: 200-1000 g</p> <p>Accessories: </p> <p>NOT SUITABLE FOR SAUSAGES, which can be defrosted manually using defrost power and time. Chops and chicken portions should be arranged in a single layer and turned frequently during defrosting. It is necessary for mince to be broken up frequently during defrosting and this is best carried out in a large shallow dish.</p> <p>See "Defrosting charts" for standing time.</p>
<div data-bbox="344 1370 416 1411" style="border: 1px solid black; padding: 2px; width: fit-content; margin: 0 auto;">Meat Joints</div> <p>(Whole Chickens, etc.)</p>	<p>Weight: 600-1600 g</p> <p>Accessories: </p> <p>Whole chickens and meat joints will require shielding during defrosting especially if it is a particularly fatty piece. This is to prevent food starting to cook on the outside edges. Protect wings, breast and fat with smooth pieces of aluminium foil secured with cocktail sticks. DO NOT ALLOW THE FOIL TO TOUCH THE WALLS OF THE OVEN.</p> <p>Standing time of at least 1 hour should be allowed for joints after defrosting.</p>

Defrosting guidelines

For Best Results:

1. Place foods in a suitable container. Meat joints and chickens should be placed on an upturned saucer or on a plastic rack if you have one.
2. Check food during defrosting, as foods vary in their defrosting speed.
3. It is not necessary to cover the whole food (see point 6).
4. Always turn or stir the food halfway. Shield if necessary (see point 6).
5. Minced meat, chops and other small items should be broken up or separated and placed in a single layer.
6. Shielding prevents food from cooking. It is essential when defrosting chickens and joints of meat. The outside thaws out first, so protect wings/breast/fat/bones with smooth pieces of aluminium foil secured with cocktail sticks.
7. Allow standing time so that the centre of the food thaws out (minimum of 1 hour for joints of meat and whole chickens).

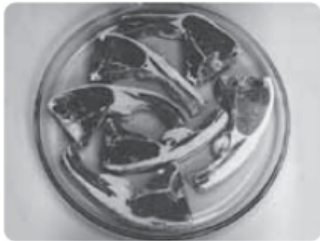

Arrange food in a single layer.

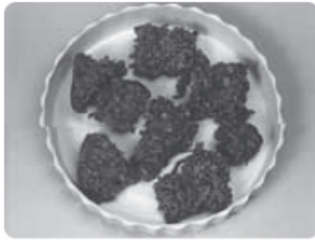

Turn or break up food as soon as possible.



Shield chickens and joints of meat.

Auto reheat/auto cook



Press a desired Auto Reheat/ Auto Cook pad several times until the appropriate weight appears.



Press Start.
The time counts down in the display.

Notes



1. Only use the accessories as indicated below.
2. Large pieces of fish/meat in a thin sauce, may require longer cooking.
3. These programs are not suitable for foods that cannot be stirred.

4. Meals in bowl shaped containers will need extra cooking time.
5. As some variations may occur in food, check that food is thoroughly cooked and piping hot before serving.

Auto Reheat

Programme	Instructions
	<p>Weight: 200-800 g</p> <p>Accessories: </p> <p>For reheating a curry convenience meal that can be stirred. Foods must be in a suitable single section microwaveable container and have the film pierced. Place it on the glass tray. Press Curry several times until the appropriate weight appears, and press Start. Stir at beeps. Allow to stand for 1 minute. Ensure the food is piping hot. Stir the food before serving.</p>
	<p>Weight: 200-500 g</p> <p>Accessories: </p> <p>For reheating a Chinese style convenience meal that can be stirred. Foods must be in a suitable single section microwaveable container and have the film pierced. Place it on the glass tray. Press Chinese several times until the appropriate weight appears, and press Start. Stir at beeps. Allow to stand for 1 minute. Ensure the food is piping hot. Stir the food before serving.</p>
	<p>Weight: 200-800 g</p> <p>Accessories: </p> <p>For reheating a pasta style convenience meal that can be stirred. Foods must be in a suitable single section microwaveable container and have the film pierced. Place it on the glass tray. Press Pasta several times until the appropriate weight appears, and press Start. Stir at beeps. Allow to stand for 1 minute. Ensure that the food is piping hot. Stir the food before serving</p>

Auto Cook

Programme	Instructions
	<p>Weight: 200-1000 g</p> <p>Accessories: </p> <p>For cooking jacket potatoes. Choose medium sized potatoes 200-250 g (7-9 oz). Wash and dry and prick with a fork several times. Arrange around the edge of glass tray. Press Jacket Potatoes several times until the appropriate weight appears, and press Start. DO NOT COVER.</p>
	<p>Weight: 100-1000 g</p> <p>Accessories: </p> <p>For cooking FRESH vegetables. Place prepared vegetables into a shallow container on the glass tray. Add 15 ml (1 tbsp) of water per 100 g of vegetables. Cover with pierced cling film or lid. Press Fresh Vegetables several times until the appropriate weight appears, and press Start. Stir/rearrange if necessary when the oven beeps.</p>
	<p>Weight: 200-800 g</p> <p>Accessories: </p> <p>For cooking FRESH fish. Shield the thinner portions. Place in a shallow container on the glass tray. Add 15-45 ml (1-3 tbsp) of liquid. Cover with pierced cling film or lid. Press Fresh Fish several times until the appropriate weight appears, and press Start.</p>

Questions and answers

Q: Why won't my oven turn on?

A: When the oven does not turn on, check the following:

1. Is the oven plugged in securely? Remove the plug from the outlet, wait 10 seconds and reinsert.
2. Check the circuit breaker and the fuse. Reset the circuit breaker or replace the fuse if it is tripped or blown.
3. If the circuit breaker or fuse is all right, plug another appliance into the outlet. If the other appliance works, there probably is a problem with the oven. If the other appliance does

not work, there probably is a problem with the outlet. If it seems that there is a problem with the oven, contact an authorised Service Centre.

Q: My oven causes interference with my TV. Is this normal?

A: Some radio and TV interference might occur when you cook with the oven. This interference is similar to the interference caused by small appliances such as mixers, vacuums, blow dryers, etc. It does not indicate a problem with your oven.

Q: The oven won't accept my programme. Why?

A: The oven is designed not to accept an incorrect programme. For example, the oven will not accept a 4th stage.

Q: Sometimes warm air comes from the oven vents. Why?

A: The heat given off from the cooking food warms the air in the oven cavity. This warmed air is carried out of the oven by the airflow pattern in the oven. There are no microwaves in the air. The oven vents should never be blocked during cooking.

Care of your oven

1. The oven should be unplugged before cleaning.
2. Clean the inside of the oven, door seals and door seal areas regularly. When food splatters or spilled liquids adhere to the oven walls, door seals and door seal areas wipe off with a damp cloth. Mild detergent may be used if they get very dirty. The use of harsh detergent or abrasive is not recommended. Avoid cleaning the microwave feed guide area situated on the right hand side of the cavity wall. **DO NOT USE COMMERCIAL OVEN CLEANERS.**
3. Do not use harsh, abrasive cleaners or sharp metal scrapers to clean the oven door glass since they can scratch the surface, which may result in shattering the glass.
4. The outside oven surface should be cleaned with a damp cloth. To prevent damage to the operating parts inside the oven, water should not be allowed to seep into the ventilation openings.
5. If the Control Panel becomes dirty, clean it with a soft cloth. Do not use harsh detergents or abrasives on the Control Panel. When cleaning the Control Panel leave the oven door open to prevent the oven from accidentally turning on. After cleaning press Stop/Reset to clear display window.
6. If steam accumulates inside or around the outside of the oven door, wipe with a soft cloth. This may occur when the oven is operated under high humidity conditions and in no way indicates a malfunction of the unit.
7. It is occasionally necessary to remove the glass tray for cleaning. Wash the tray in warm soapy water or in a dishwasher.

8. The roller ring and oven cavity floor should be cleaned regularly to avoid excessive noise. Simply wipe the bottom surface of the oven with mild detergent and hot water then dry with a clean cloth. The roller ring may be washed in mild soapy water. Cooking vapours collect during repeated use but in no way affect the bottom surface or roller ring wheels. After removing the roller ring from the cavity floor for cleaning, be sure to replace it in the proper position.
9. A steam cleaner is not to be used for cleaning.
10. This oven should only be serviced by qualified personnel. For maintenance and repair of the oven contact the nearest authorised dealer.
11. Failure to maintain the oven in a clean condition could lead to deterioration of surfaces that could affect the life of the appliance and possibly result in a hazardous situation.
12. Keep air vents clean at all times. Check that no dust or other material is blocking any of the air vents on the top, bottom or rear of the oven. If air vents become blocked this could cause overheating which would affect the operation of the oven and possibly result in a hazardous situation.

Specifications

Power Source:	230-240 V, 50 Hz
Power Consumption:	Maximum; 1250 W
Output:	800 W (IEC-60705)
Outside Dimensions:	443 mm (W) x 330 mm (D) x 258 mm (H)
Oven Cavity Dimensions:	306 mm (W) x 308 mm (D) x 214 mm (H)
Overall Cavity Volume:	20 L
Glass Tray Diameter:	255 mm
Operating Frequency:	2450 MHz
Net Weight:	11 kg
Noise:	L_{WA} 63 dB

Weight and Dimensions shown are approximate.

Warning

This content is compiled from multiple sources and is provided for reference purposes only. It may not be complete or fully applicable to all situations. If you are unable to resolve your issue, please contact the product manufacturer or an authorized service provider for official support.

