

Parts and Accessories



Control and Features

CONTROL PANEL





PROGRAM SETTING

Function Buttons	Default Time	Cooking Time Range	Time Adjust Increment	Temperature Adjust Range	Temperature Range		Pressure	
					° C	° F	kPa	PSI
Slow Cook	6 hrs	2~12hrs	30 mins	N/A	70~93	174~199	<30	<4.3
Rice	10 mins	1~30 mins	1 min	N/A	109	228	50	7.2
Poultry	15 mins	1 min ~ 2 hrs	1 min	N/A	109	228	50	7.2
Sous Vide	90 mins	1~12 hrs	30 mins	120 ° F~175 ° F Default temp: 140 ° F	60	140	N/A	
Saut é	20 mins	1~30 mins	1 min	250 ° F~390 ° F Default temp: 355 ° F	120~200	250~390	N/A	

Bean	15 mins	5~30 mins	1 min	N/A	109	228	50	7.2
Soup	30 mins	10 mins ~2 hrs	1 min	N/A	109	228	50	7.2
Steam	10 mins	1~90 mins	1 min	N/A	109	228	50	7.2
Yogurt	8 hrs	6~12 hrs	30 mins	N/A	40	104	N/A	
Canning	45 mins	10 mins ~2 hrs	5 mins	N/A	116	241	82.7	12
Meat/Stew	15 mins	15 mins ~2 hrs	1 min	N/A	109	228	50	7.2
Pasta	10 mins	1 min ~ 1 hr	1 min	N/A	100	212	50	7.2
Preset time	N/A	N/A	30 mins	N/A	N/A		N/A	

SPECIFICATIONS

Model	Power Supply	Rated Power	Capacity of Inner Pot	Working Pressure
YBW40P	120V~60Hz	800W	4 Qt	0 - 80 kPa
YBW50P	120V~60Hz	900W	5 Qt	0 - 80 kPa
YBW60P	120V~60Hz	1000W	6 Qt	0 - 80 kPa
YBW80P	120V~60Hz	1300W	8 Qt	0 - 80 kPa
YBW100P	120V~60Hz	1400W	10 Qt	0 - 80 kPa
YBW120P	120V~60Hz	1400W	12 Qt	0 - 80 kPa

General Operating Instructions

BEFORE THE FIRST USE

Please pay attention to manual and cautions to avoid any injury or property damage.
Please wash the inner pot, lid, lid filter plate and silicon gasket with soapy water. Rinse with clean water and dry thoroughly.

GETTING STARTED

1. To open lid, grip lid handle and turn clockwise, as indicated on handle, and lift upward.

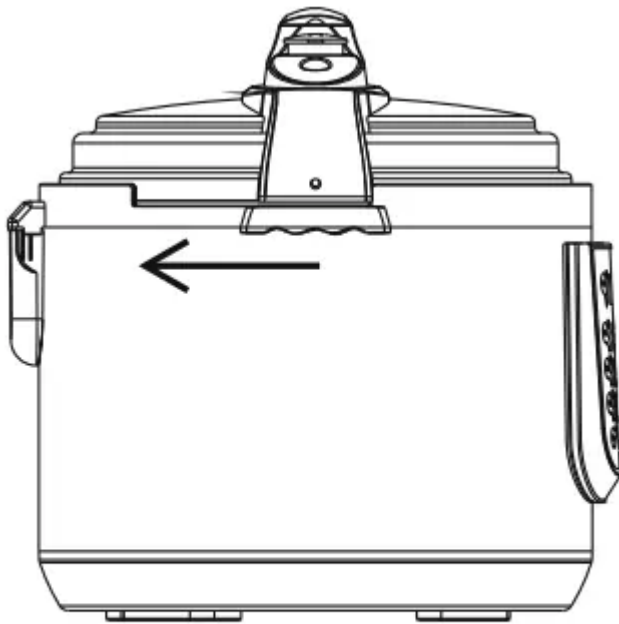

1

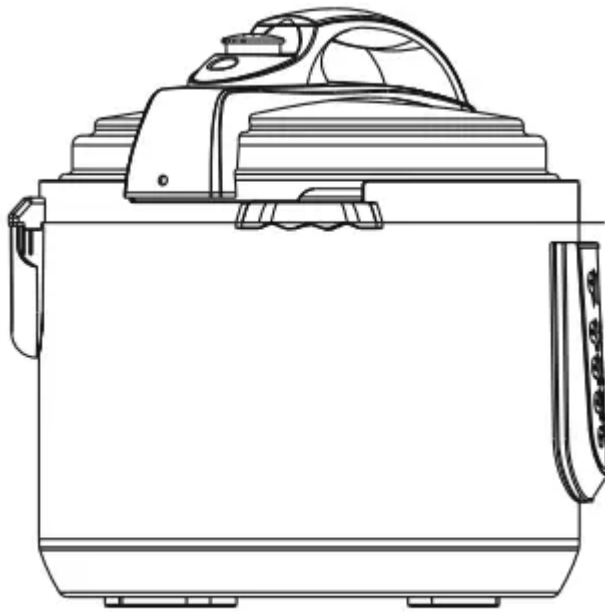

2

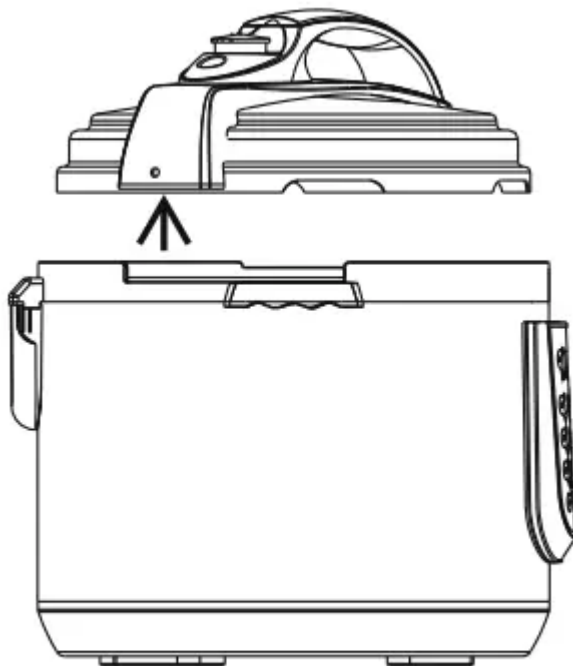

3

2. Remove the inner pot and place cooking ingredients inside. Monitor the level of the water and ingredients per cooking instructions to ensure they do not exceed the MAX LINE “4/5” marking on the inner pot (see picture 4). Rice, beans, or other ingredients that will expand during cooking should not be filled beyond the “10 CUP” marking (see picture 5).

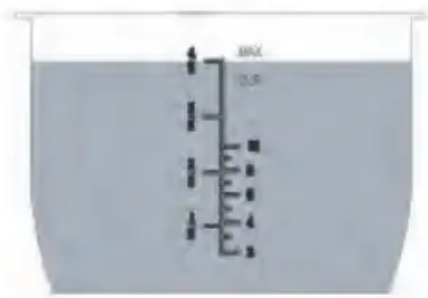

4

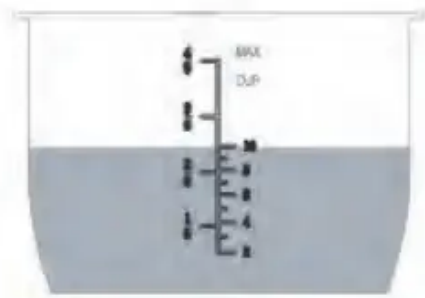

5

3. Clean and towel dry the external surface of the inner pot, place Inner Pot inside the cooker, rotating it slightly to ensure proper contact with the heating element. Make sure there is no material between the inner pot and the exterior pot before you insert it into the cooker (see picture 6)



6

4. To close Lid, place lid on pressure cooker, turn handle counter-clockwise to CLOSE position as indicated on handle, until lid locks in place (see pictures 7 to 11)

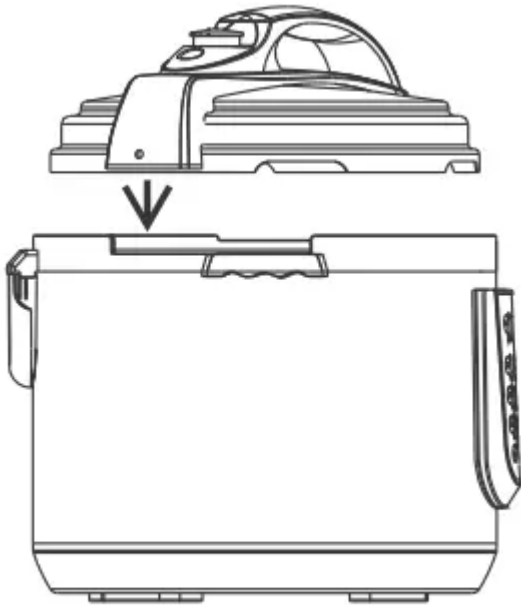

7

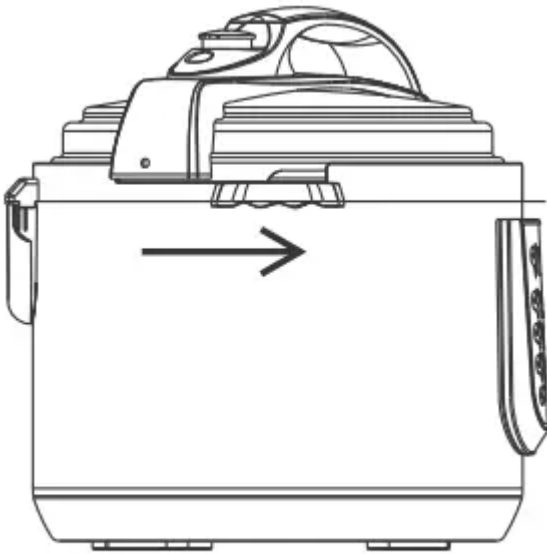

8



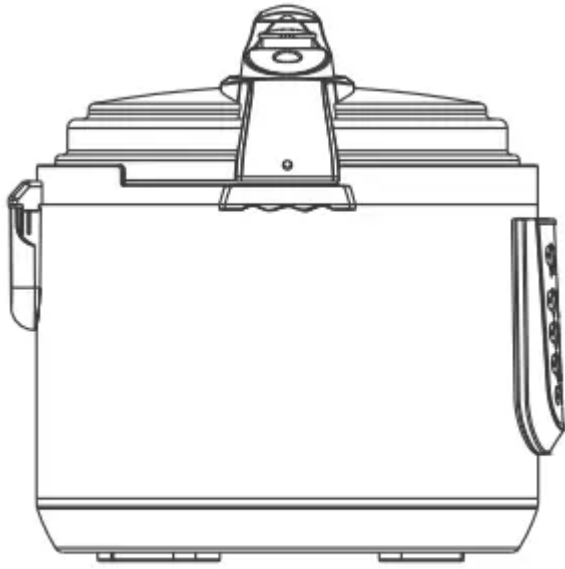

9

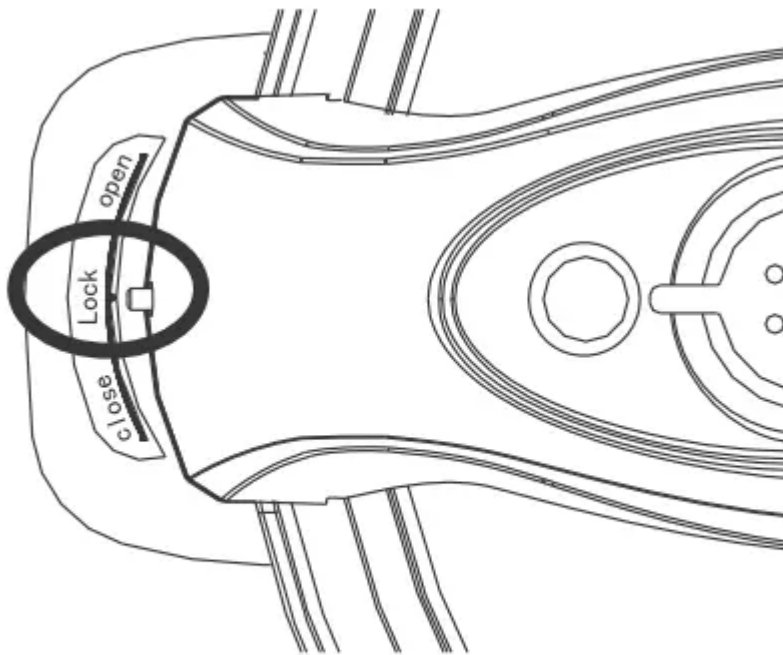

10 Close position

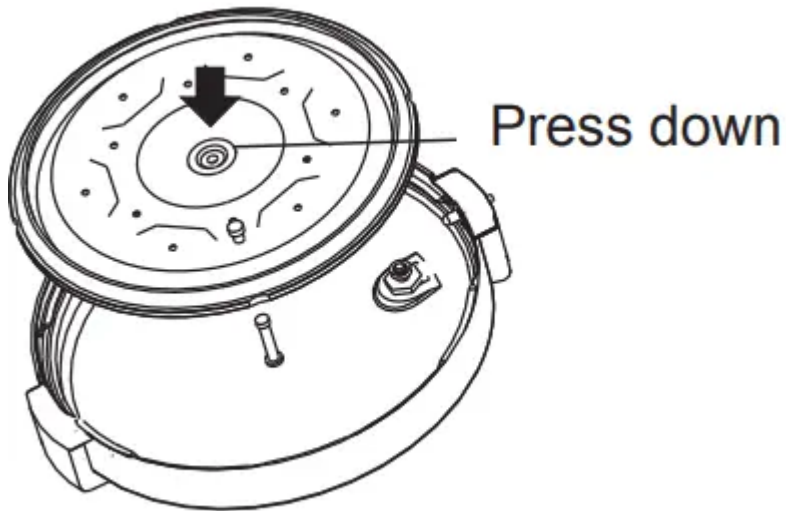
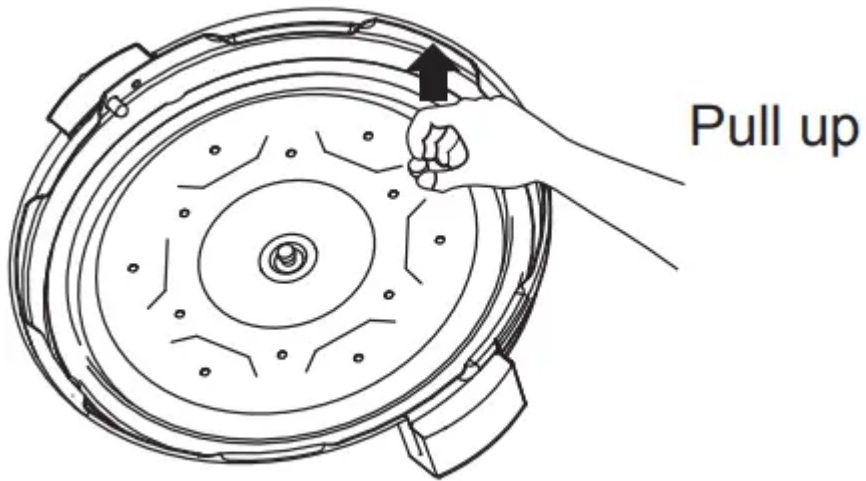

INSTALL THE ANTI-BLOCK SHIELD



Shield in place and push down

To install: Position the Anti-Block



To remove: Using your thumb, push the side of the Anti-Block Shield towards the lid rim and lift up with some effort. The Anti-Block Shield should pop out.

SAFE LID OPENING

Make sure the pressure cooking program has completed or press “Warm/Cancel” key to turn off the program.

Releasing pressure in one of the following ways.

1. Quick Release:

Turn the Pressure Valve handle to the “Venting” position to let out steam until the float valve drops down

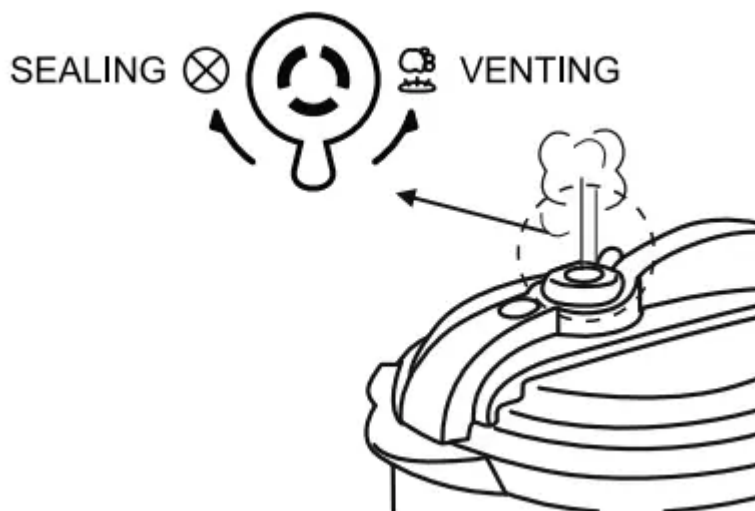

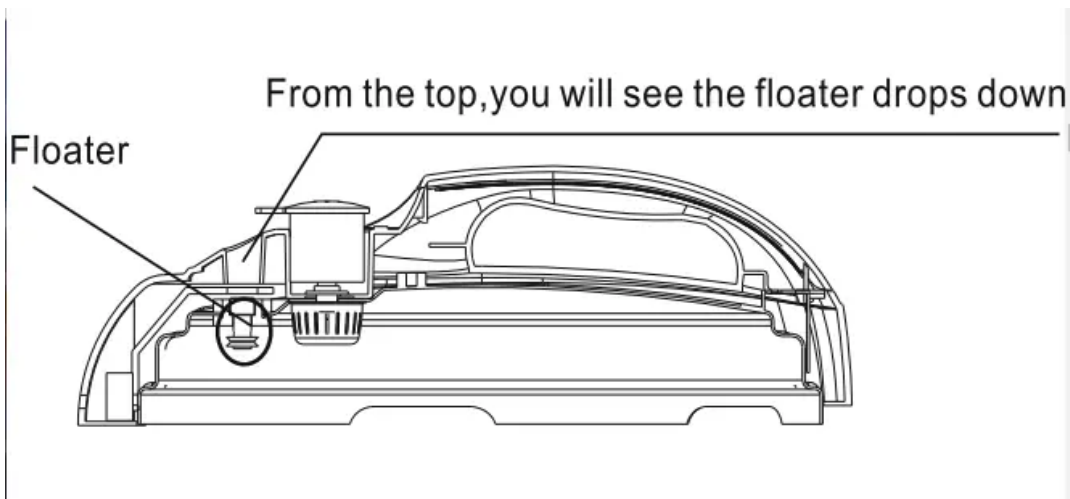

2. Natural Release:

Allow the cooker to cool down naturally until the float valve drops down. This may take up to 15 to 40 minutes, or even more, depending on the amount of food in the cooker. Place a wet towel on the lid to speed up cooling. After cooking is finished, turn OFF Keep Warm mode if it is turned ON.

HOW TO USE

Programs	Instructions
Preset Time	<p>1. Press "Preset Time" key to start delayed cooking, use "+" or "-" keys to set the delayed hours. The green LED light behind "Preset Time" key will be light up.</p> <p>2. Select the desired cooking function (all functions except "Sauté", "Yogurt" and "Keep Warm").</p> <p>3. Cooking starts automatically in 5 seconds after the last key is pressed</p>
Warm/ Cance	<p>Press "Warm/Cancel" key will cancel the program and take the cooker to standby mode.</p> <p>When the cooker is in standby mode, pressing this key activates the keep-warm program. "Keep Warm" cycle for 8 hours. If the 8 hours auto "Keep Warm" cycle finishes, the cooker goes into standby mode.</p>
Time/Temp	<p>Press "Time/Temp" key to set cooking time or temperature, the LED display will flash at setting mode.</p>
+/-	<p>To increase or decrease cooking time or cooking temperature. Press and hold the key for faster changes</p>
Yogurt	<p>The "Yogurt" key is to make yogurt and pasteurize milk.</p> <p>A. Press "Yogurt" key one time to enter Yogurt function, cooking time will appear on the LED display. Press "Time/Temp" key to set cooking time, then change cooking duration by pressing "+" or "-" key. When the process is completed, display appears "yogt".</p> <p>B. Press "Yogurt" key twice time to enter pasteurize milk function. The display appear boil, and the temperature is 180F/83C. When the process is completed, display appears "yogt". If you want to make yogurt, please let it cool to below 115F/46C and refer to below point C operation.</p> <p>C. If you use a container or bottles to make yogurt, add an adequate amount of yogurt starter or fresh yogurt to container or bottle. Then place them into inner pot with water. Then press "Yogurt" key. The LED display will appear "yogt" when the process is completed.</p>
Steam	

	<p>The "Steam" key is to steam vegetables, seafood or reheating. Add 3 cups of water into the inner pot using the plastic measuring cup provided, and use the stainless steel rack provided to elevate the food above the water.</p> <ol style="list-style-type: none"> 1. Press "Steam" key. 2. Press "Time/Temp" key to set cooking time, then change steaming duration by pressing "+" or "-" key. 3. Cooking starts automatically in 5 seconds after the last key is pressed.
Pasta	<p>The "Pasta" key is specifically for cooking pasta, noodle and spaghetti etc.</p> <ol style="list-style-type: none"> 1. Press "Pasta" key. ' 2. Press "Time/Temp" key to set cooking time, then change cooking duration by pressing "+" or "-" key. 3. Cooking starts automatically in 5 seconds after the last key is pressed.
Rice	<p>The "Rice" key is program for cooking regular rice. Depends on the rice and water volume, or your desired rice texture, use "Time/Temp" key to set cooking time, otherwise it cooks automatically.</p> <ol style="list-style-type: none"> 1. Press "Rice" key. 2. Press "Time/Temp" key to set cooking time, then change cooking duration by pressing "+" or "-" key. 3. Cooking starts automatically in 5 seconds after the last key is pressed.
Bean/Chili	<p>The "Bean/Chili" key is specifically for cooking beans and making Chili. If you want the beans well cooked, please use the "Time/Temp" key to add cooking time.</p> <ol style="list-style-type: none"> 1. Press "Bean/Chili" key. 2. Press "Time/Temp" key to set cooking time, then change cooking duration by pressing "+" or "-" key. 3. Cooking starts automatically in 5 seconds after the last key is pressed.

Canning	<p>The "Canning" key is for sterilization of utensils and canning of acidic fruits and vegetables, minimize the possibility of spoilage and contamination.</p> <ol style="list-style-type: none"> 1. Press "Canning" key. 2. Press "Time/Temp" key to set cooking time, then change canning duration by pressing "+" or "-" key. 3. Canning starts automatically in 5 seconds after the last key is pressed.
Poultry	<p>The "Poultry" key is programmed to make poultry dishes. Poultry meat is generally easier to cook than pork, lamb and beef. Hence the poultry cooking time is adjusted within 15 minutes range when using the "Poultry" function key.</p> <ol style="list-style-type: none"> 1. Press "Poultry" key. 2. Press "Time/Temp" key to set cooking time, then change cooking duration by pressing "+" or "-" key. 3. Cooking starts automatically in 5 seconds after the last key is pressed.
Soup/ Porridge	<p>The "Soup/Porridge" key is to make soup and porridge.</p> <ol style="list-style-type: none"> 1. Press "Meat/Stew" key. 2. Press "Time/Temp" key to set cooking time, then change cooking duration by pressing "+" or "-" key. 3. Cooking starts automatically in 5 seconds after the last key is pressed.
Meat/Stew	<p>The "Meat/Stew" key is for cooking pork, lamb and beef.</p> <ol style="list-style-type: none"> 1. Press "Meat/Stew" key. 2. Press "Time/Temp" key to set cooking time, then change cooking duration by pressing "+" or "-" key. 3. Cooking starts automatically in 5 seconds after the last key is pressed.
Slow Cook	<ol style="list-style-type: none"> 1. The "Slow Cook" key allows you to use your cooker as a slow cooker. The Pressure Valve handle should be at the "Venting" positions.

	<ol style="list-style-type: none"> 2. Press "Slow Cook" key. 3. Press "Time/Temp" key to set cooking time, then change cooking duration by pressing "+" or "-"key. 4. Cooking starts automatically in 5 seconds after the last key is pressed.
Sauté	<ol style="list-style-type: none"> 1. The "Sauté" key is used for open lid sautéing, browning or simmering inside the inner pot. Keep the lid open to avoid pressure from building up inside the cooker. 2. Press "Sauté" key. 3. "Time/Temp" can be used to change the cooking time and temperature via "+" or "-" keys. Press "Time/Temp" key one time is for changing cooking time. Press "Time/Temp" key twice times is for changing cooking temperature. 4. Cooking starts automatically in 5 seconds after the last key is pressed. 5. When the process is completed, the cooker goes into standby mode.
Sous Vide	<ol style="list-style-type: none"> 1. The "Sous Vide" key allows you to use your cooker as a Sous Vide cooker. The Pressure Valve handle should be at the "Venting" positions. 2. Press "Sous Vide" key. 3. "Time/Temp" can be used to change the cooking time and temperature via "+" or "-" keys. Press "Time/Temp" key one time is for changing cooking time. Press "Time/Temp" key twice times is for changing cooking temperature. 4. Cooking starts automatically in 5 seconds after the last key is pressed.

Safety And Cooking Tips

- Extreme caution should be taken when moving the pressure valve handle to Venting position. Keep hands and face away from the pressure valve openings. Failure to comply may result in scalding or serious injury.
- Do not open the lid until pressure inside the cooker is completely released. As a safety feature, until the float valve drops down the lid is locked and cannot be opened. DO NOT force lid open.

- When opening the lid, the inner pot may adhere to the lid. This is caused by vacuum due to cooling. To release the vacuum, move the pressure valve handle to the Venting position.
- If the float valve is stuck, move the pressure valve to the Venting position. Once all the steam is released, push the float valve down with a pen or long stick.
- Always add at least 1 cup / 250 ml of water or other liquids so enough steam can be generated to cook under pressure. These include cooking sauces, wine, beer, stocks, juices of fruits and vegetables. Oils and oil-based sauces do not have enough water content and will not account for the required liquid volume.
- Time to pressure and cooking time will vary according to the temperature and quantity of the ingredients. Food that is cold or frozen will take longer to cook than food that is at room temperature.
- When using the Preset Time (Delay Start) program, allow sufficient cooling down time before serving.
- The Preset Time (Delay Start) program is not recommended for porridge, oatmeal or other foamy and thick liquids. Cooking progresses should be monitored when cooking these foods.

Care and Cleaning

Regular care or maintenance is essential in ensuring that GeekChef pressure cooker is safe for use. The GeekChef pressure cooker must be cleaned thoroughly after each use in order to avoid staining caused by a build-up of food or cooking residue.

- Both the inner pot and lid are dishwasher safe.
- Remove the inner pot and lid and wash with detergent. Rinse with clear water and wipe dry with a soft cloth.
- Wipe the inner cooker base rim and slot dry with cloth to prevent rusting of the exterior cooker rim.
- Remove the lid filter plate and anti-block shield from the underside of the lid. Wash with warm, soapy water, rinse with clear water and wipe dry with a soft cloth.
- When cleaning the lid filter plate, the Silicon Gasket must be removed and washed separately with warm, soapy water, rinse with clear water and wipe dry with a soft cloth.
- The Silicon Gasket must always be properly positioned on the Lid Filter Plate.
- Clean the outer body with a damp soft cloth or sponge.
- Never use harsh chemical detergents, scouring pads or powders on any of the parts or components.

- Periodically check that the pressure valve and float valve are in good working order and free of debris.
- Never immerse the outer housing and power cord in water or any other liquid.



Troubleshooting



PROBLEM	PROBABLE CAUSE	SOLUTION
Difficulty with closing the lid	Silicon gasket is not properly installed	Position the silicon gasket well.
	Float valve in the popped-up position	Slightly press the float valve downward.
Difficulty with opening the lid	Pressure exists inside the cooker	Position the steam release valve to the venting position to reduce the internal pressure. Open the lid after the pressure is completely released.
	Float valve stuck at the popped-up position.	Press the float valve lightly with a pen or long utensil.
Steam leaks from the rim of the lid	Steam leaks from the rim of the lid	Install the silicon gasket
	Food debris attached to the silicon gasket	Clean the silicon gasket
	Silicon gasket or lid filter plate damaged	Replace the silicon gasket or lid filter plate
	Lid not closed properly	Open then close the lid again
Steam leaks from the float valve	Food debris on the float valve silicone seal	Clean the float valve silicone seal
	Float valve silicone ring worn-out	Replace the float valve silicone ring
Float valve unable to rise	Too little food or water in inner pot	Add water according to the recipe
	Float valve obstructed by the lid locking pin	Close the lid completely, see “GENERAL OPERATION INSTRUCTIONS” section
Steam comes out from the pressure valve non-stop	Pressure valve not in sealing position	Turn the pressure valve handle to the sealing position
	Pressure control fails	Contact customer services

Rice is half cooked or too hard	Too little water	Adjust dry rice and water ratio according to recipe
	Lid opened too early	After cooking cycle completes, leave the lid on for 5 more minutes
Rice is too soft	Too much water	Adjust dry rice and water ratio according to recipe
Display remains blank after connecting the power cord	Bad power connection or no power	Inspect the power cord to ensure a good connection, check if the power outlet is active
	Cooker's electrical fuse has blown	Contact customer services
Occasional ticking or light cracking sound	The sound of power switching and expanding pressure board when changing temperature	This is normal
	Bottom of the inner pot is wet	Wipe bottom of the inner pot dry before cooking
Displays "E03" error code	Food burned on the bottom of inner pot	Clean the sticky or burned food off the inner pot
	Overheating, power board is malfunction	Contact customer services
Displays "E01", "E02" or "E04" error code	The cooker is malfunction	Contact customer services

Warning

This content is compiled from multiple sources and is provided for reference purposes only. It may not be complete or fully applicable to all situations. If you are unable to resolve your issue, please contact the product manufacturer or an authorized service provider for official support.