

## PARTS AND FEATURES

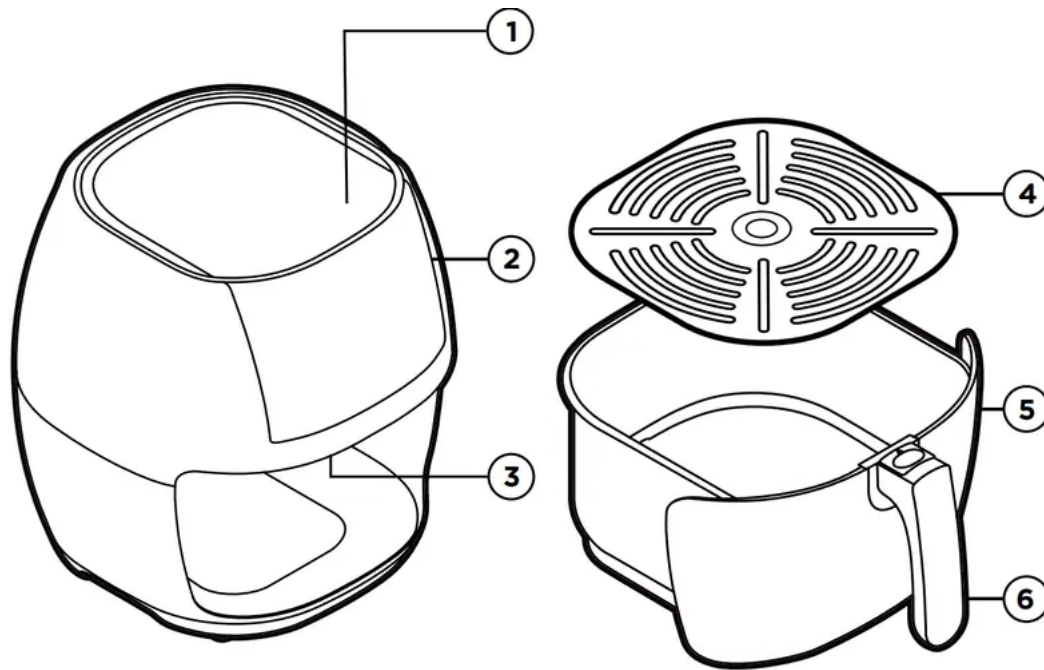

- 1. Control Panel
- 2. Viewing Window
- 3. Automatic Light (inside)

- 4. Removable Basket Rack
- 5. 8-Quart Basket
- 6. Basket handle

# CONTROL PANEL

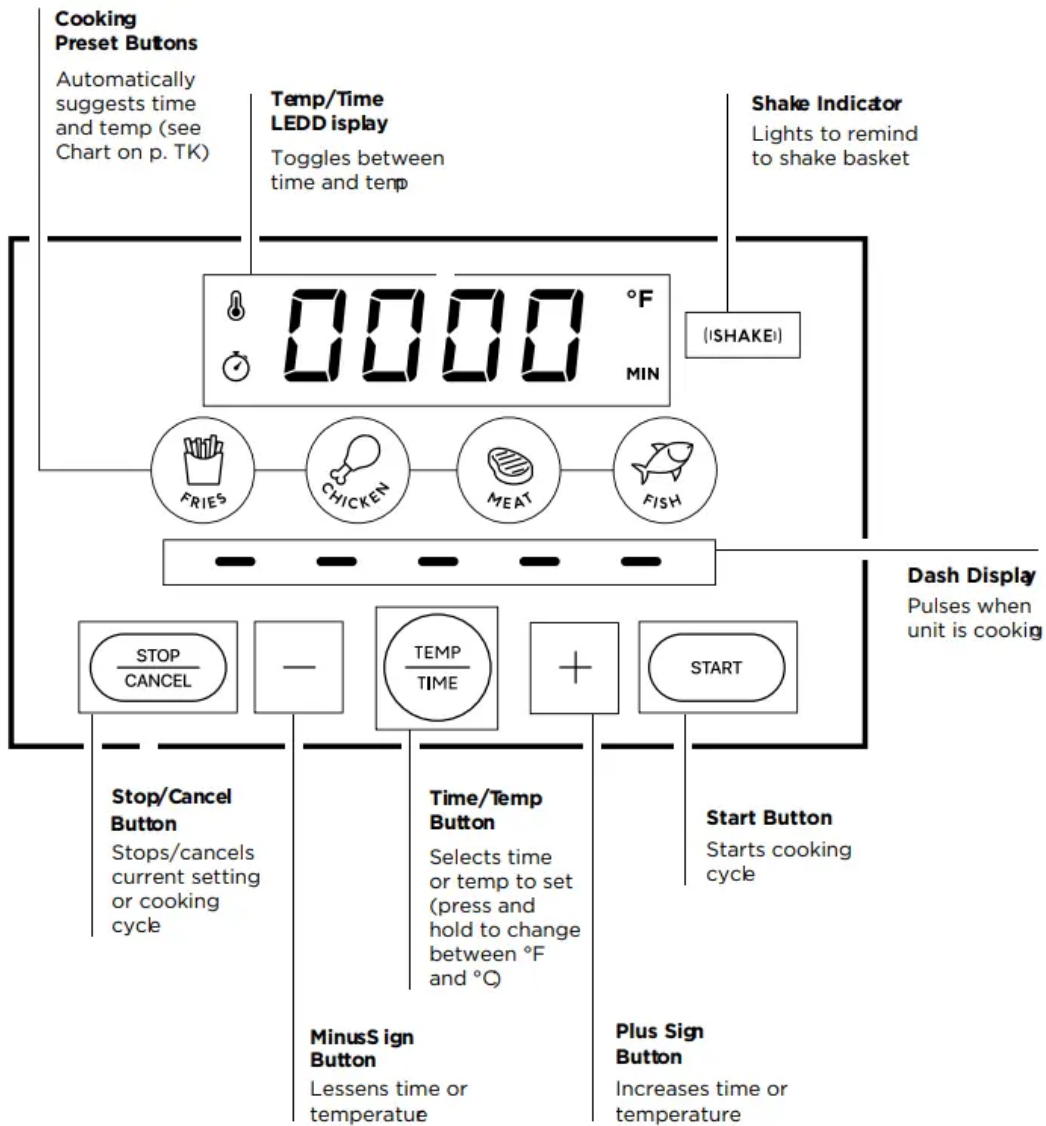

## PRESET FUNCTIONAL CHART

FUNCTION	Default Time	Default Temp	Shake Timing <small>(NOTE: If time is set for more than 30 minutes, "Shake" light will come on every 15 minutes)</small>
Default	15 min.	400°F	"Shake" light comes on halfway through.
Meat	18 min.	375°F	"Shake" light comes on halfway through.
Chicken	22 min.	375°F	"Shake" light comes on halfway through.
Fish	10 min.	350°F	"Shake" light comes on halfway through.
Fries	20 min.	400°F	"Shake" light comes on every 5 minutes.

## HOW TO COOK THE TURBOFRY® TOUCH AIR FRYER

<p><b>STEP 1</b></p> <p>Place prepared food on rack in basket.</p> <p><b>CAUTION:</b> Never fill the basket with oil.</p>	
<p><b>STEP 2</b></p> <p>Slide the basket into the air fryer.</p>	
<p><b>STEP 3</b></p> <p>Set the time and temperature as desired or select a preset button, then press START.</p>	
<p><b>STEP 4</b></p> <p>During cooking, the "Shake" light will come on. Shake foods if desired.</p> <p><b>When the timer is done, remove basket and serve.</b></p>	

## OPERATING INSTRUCTIONS

### BEFORE FIRST USE

---

For best results, follow these steps before using your TurboFry® Touch Air Fryer for the first time.

1. Remove all packaging materials, such as plastic bags and foam inserts.
2. Read and remove any stickers on the unit except for the rating label on the bottom, which should remain on the unit.
3. Check to ensure that all parts and accessories are accounted for.
4. Wipe down the interior and exterior with a damp cloth.
5. Wash the basket and basket rack with warm, soapy water. Dry thoroughly. The basket and rack are also top-rack dishwasher safe.

## HOW TO COOK IN THE TURBOFRY® TOUCH AIR FRYER

---

The air fryer's high-speed fan cooks your favorite foods quickly. The rack in the basket allows air to circulate around foods for even cooking and crisping and lets excess fat drip down and away from foods for healthier eating.

**CAUTION:** Never fill the basket with oil. Unlike deep fryers, air fryers require little to no oil to produce a crisp texture. If you choose to use oil, toss foods with just a little in a separate bowl before cooking in the air fryer.

1. Prepare the food(s) you plan to air fry.
2. Place the air fryer on a hard, flat surface and plug it in. The control panel will illuminate, and the default temperature and time will alternate on the display.
3. Pull out the basket and insert the basket rack. (For easiest handling of the basket rack, pinch the center grip bar with thumb and index finger.)

**CAUTION:** Never spray the basket or rack with cooking oil from an aerosol spray can, which includes harsh components that can cause chipping of the nonstick coating. However, you can oil the tray or spray it with oil from a non-aerosol mister.

---

1. Put the food on the rack. Do not let it surpass the MAX line embossed on the basket.
2. Slide the basket into the air fryer.
3. Set the time and temperature as desired or use pre-set cooking parameters.
  - a. To manually set the temperature, press the TEMP/TIME button until the temperature displays, and then press the plus or minus sign button. To manually set the time, press the TEMP/TIME button until the time displays and then press the plus or minus sign button.
  - b. To cook with pre-set cooking parameters, choose the icon that best represents the food you're cooking and press the icon button. This will set the pre-programmed time and temperature. **NOTE:** Pressing STOP/CANCEL when the

unit is not active will cancel the selected preset and return the unit to the air fry default.

4. Press START. The interior light will automatically come on and stay on during cooking.  
**NOTE:** During cooking, you can remove the basket to check on, turn, or shake foods. When you return the basket to the unit, the timer and heating will resume where it left off. To stop cooking before the timer ends, press STOP/CANCEL.
5. During cooking, the "Shake" light on the control panel will turn on and the air fryer will beep as a reminder to shake (or flip) food, as necessary. (See Chart, p. 7 for more details on timing.) The "Shake" light will turn off immediately when the basket is removed and will go off automatically after about 15 seconds if basket is not pulled out. (If your food does not need to be shaken, flipped, or turned, simply ignore the warning.)
6. When the timer is done, the air fryer will turn off automatically. Remove the basket from the air fryer. Check food for doneness, then carefully transfer food to plates or a platter and serve. **NOTE:** On first use, unit may emit a slight odor, which is normal and will dissipate with use.

## AIR FRYER COOKING TIPS

**Preheat the air fryer for 5 minutes before cooking.** While not necessary, preheating the unit will cook foods faster and promote crisp results. If the unit is cold, add a few minutes to your expected cooking time. **CAUTION:** Be careful when adding food after preheating as inside of fryer will be hot.

**For a crisp exterior, oil foods lightly.** Some foods, especially if fresh, benefit from being tossed with a little oil in a separate bowl before frying. However, high-fat foods like a well marbled steak, or prepared foods, usually require no additional oil.

**Avoid wet batters.** Loose batters, such as those used for deep frying, do not work in air fryers, as the batter simply slides off. Adapt such recipes to give foods a thicker coating, preferably including breadcrumbs to help the coating adhere.

**Use medium-high to high heat for most cooking.** Most foods will air fry best between 325°F and 400°F. For gentler cooking and reheating, use a lower temperature to avoid overcooking.

**Don't overcrowd the basket.** Too much food, especially if tightly packed, can inhibit browning and crisping. A better bet: Fry food in batches.

**Shake the basket during cooking for even cooking.** A good shake is especially beneficial for smaller items like french fries, onion rings, and chicken wings. For larger or more fragile foods, consider gently tossing or flipping for even results.

**Check on foods early.** Check foods on the earlier side of cooking time; you can always slide the basket back in to continue cooking.

**Follow food safety guidelines for doneness.** Because air fryer temperatures and food sizes can vary, do not rely on recipe timing only when cooking food. Check foods for doneness against current safety guidelines before serving

## CLEANING AND MAINTENANCE

The nonstick coating on the basket and rack makes the air fryer easy to clean following the steps below.

1. Unplug unit and let cool completely before cleaning. (For faster cooling, take hot basket out of the unit.)
2. To remove the cooled rack from basket, pinch the center grip bar at the bottom of the basket, and pull rack straight up and out of basket. **WARNING:** Do not lift rack out of basket when hot or injury can occur.
3. Wash the basket and rack with warm soapy water, rinse, and dry well with a towel for best results. Basket and rack are also top-rack dishwasher-safe.
4. Wipe down the outside and the inside of the unit with a damp cloth as needed. Do not put the unit in the dishwasher or submerge in water or any other liquid.
5. Do not use abrasive cleansers on basket, rack, exterior, or interior, or you could damage the finishes.

## TROUBLESHOOTING

### Why is there white smoke coming from my unit?

- White smoke can be a sign that there's too much fat in the fryer. Avoid cooking very fatty foods, such as sausages, in the air fryer, and be sure the interior of the unit, the basket and the rack are clean before cooking.

### Why has my food cooked unevenly?

- Two culprits are likely: overcrowding and not shaking. Fill basket loosely with food to let air circulate and shake, toss, or flip foods at least once during cooking for more even results.

### Why isn't my food crisp?

- Though you can air fry with no added oil, coating foods very lightly with oil (usually just ½ teaspoon per batch for most recipes) helps guarantee crisp results. Preheating the fryer also helps.

## SAFETY INSTRUCTIONS

**WARNING:** When using electrical appliances, basic safety precautions should always be followed including the following:

Read all instructions.

1. Do not touch hot surfaces. Use handles or knobs.
2. To protect against electrical shock do not immerse cord or plug in water or other liquid.
3. Close supervision is necessary when any appliance is used by or near children.
4. Unplug from outlet when not in use and before cleaning. Allow to cool before putting on or taking off parts.
5. Do not operate any appliance with a damaged cord or plug or after the appliance malfunctions or has been damaged in any manner. Contact Chefman® Customer
6. Service.
7. The use of accessory attachments not recommended by the appliance manufacturer may cause injuries.
8. Do not use outdoors.
9. Do not let cord hang over edge of table or counter or touch hot surfaces.
10. Do not place on or near a hot gas or electric burner, or in a heated oven.
11. Extreme caution must be used when moving an appliance containing hot oil or other hot liquids.
12. To disconnect, turn any control to “off,” then remove plug from wall outlet.
13. Do not use appliance for other than intended use.
14. Place the unit on a flat, sturdy, heat resistant surface. Do not place the unit near or on any type of heat source, such as a gas or electric burner, stove, or oven. Do not use near an open flame or flammable materials.
15. The unit will emit some heat. Allow sufficient space around the unit when in use and do not place near other items or appliances.
16. Check that your home power supply corresponds with the intended voltage of air fryer.
17. Never wrap the cord tightly around the appliance during use or storage; this may cause the wire to fray and break.
18. This product is not a deep fryer. It is NOT meant to be filled with oil. Never fill any parts of the air fryer with oil. If you choose to use oil, toss food with oil in a separate bowl and then transfer food to the removeable racks or basket.
19. Do not leave uncooked ingredients in the air fryer for more than a short period of time before cooking; raw meat, poultry, fish, fruits, and vegetables can spoil.
20. Do not move the air fryer while it is full of food.
21. Do not move the unit during use. During initial use, you may notice some smoke and/or a slight odor. This is normal and should quickly dissipate. It should not happen after the appliance has been used a few more times.

22. Do not leave the air fryer unattended during use.
23. Some areas do get HOT during use and touch screen may get warm. Do not touch the heating elements. Do not place hands or other body parts near the air vents while air fryer is in use; burns may result. Take caution when handling the hot air fryer rack and all removable parts.
24. Use protective mitts and/or tongs to remove hot food from the air fryer.
25. Store the air fryer in a cool, dry place.

**WARNING:** This appliance has a polarized plug (one blade is wider than the other). This plug is intended to fit into a polarized outlet only one way. If the plug does not fit fully into the outlet, reverse the plug. If it still does not fit, contact a qualified electrician. Do not attempt to modify the plug in any way or force it into the outlet. This could result in injury or electric shock.

### **SHORT CORD INSTRUCTIONS**

A short power supply cord is provided to reduce the hazards of entanglement or tripping over a longer cord. Longer detachable power-supply cords or extension cords are available and may be used if care is exercised in their use. If a longer detachable power-supply extension cord is used:

1. The marked electrical rating of the extension cord should be at least as great as the electrical rating of the appliance.
2. The cord should be arranged so that it will not drape over the countertop or tabletop where it can be pulled on by children or tripped over.

### **POWER CORD SAFETY TIPS**

1. Never pull or yank on cord or the appliance.
2. To insert plug, grasp it firmly and guide it into outlet.
3. To disconnect appliance, grasp plug and remove it from outlet.
4. Before each use, inspect the power cord for cuts and/or abrasion marks. If any are found, this indicates that the appliance should be serviced, and the power cord replaced. Please contact Chefman® Support for assistance.
5. Never wrap the cord tightly around the appliance, as this could place undue stress on the cord where it enters the appliance and cause it to fray and break.

#### **Warning**

This content is compiled from multiple sources and is provided for reference purposes only. It may not be complete or fully applicable to all situations. If you are unable to resolve your issue, please contact the product manufacturer or an authorized service provider for official support.

