

## Connection

### Wired Internet Connection



#### Connecting to a wired (Ethernet) network

To get access to the Internet in a wired way, it is recommended to use a modem or router that supports Dynamic Host Configuration Protocol (DHCP). Modems and routers that support DHCP automatically provide the IP address, subnet mask, gateway, and DNS, so you don't have to enter them manually. Most home networks already have DHCP.

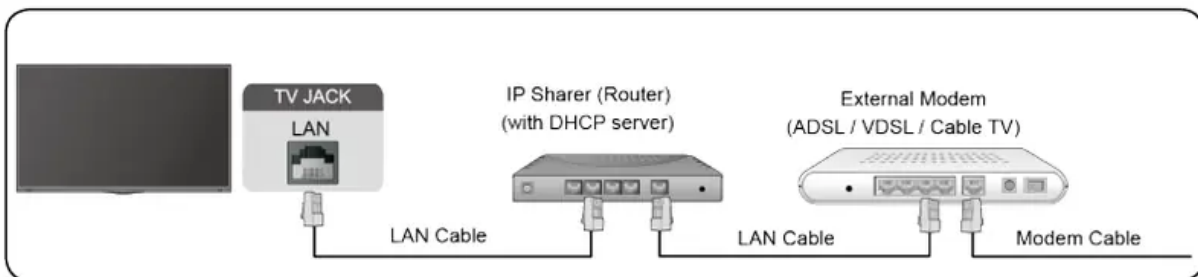
See the illustration below.





After connecting to a wired (Ethernet) network:

  >  > Settings > Network > Network Configuration Set the TV network by selecting Network Configuration and press button to enter the submenu.

Set the TV network by selecting Network Configuration and press  button to enter the submenu.

- Connection Type
  - Choose a wired (Ethernet) network connection to access the Internet.
- Ethernet
  - Display network status.
- IP Settings
  - Configure the IP setting for your network connection.

### Wake on LAN

  >  Settings > Network > Wake on LAN

Using an Ethernet connection and switching on Wake on LAN, this feature can make you turn on the TV from the standby mode, and push content to be broadcast on the TV with an app supporting the screencast feature in your mobile device.

**Note:**

- To use this function, make sure your TV and mobile device are connected to the same network environment.
- Enabling this function may result in higher energy consumption.

**Related Topic**

- Network Issues

## Wireless Internet Connection

### Connecting to a wireless network

To connect to an available wireless network, make sure that you turn on your WiFi and have the wireless router's SSID and password before attempting to connect.

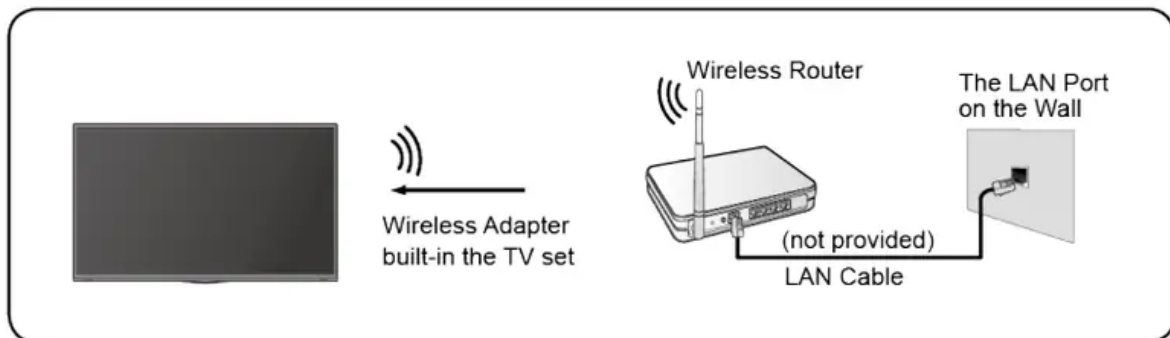

To get access to the Internet in a wireless way:

  >  Settings > Network > Network Configuration

Set the TV network by selecting Network Configuration and press  button to enter the submenu.



- Connection Type
  - Choose a wireless network connection to access the Internet.
- Advanced Settings
  - Configure the advanced wireless network settings for the TV.
- Add
  - You can add wireless network.

- Refresh
  - Refresh wireless network.

**Note:**

- If no wireless router is found, select Add and enter the network name in the SSID.
- If no wireless router is found, select Refresh.

## Wake on wireless network

  >  Settings > Network > Wake on Wireless Network

Using a wireless network connection and switching on Wake on Wireless Network, this feature can make you turn on the TV from the standby mode, and push content to be broadcast on the TV with an app supporting the screencast feature in your mobile device.

For more information about screencast feature, please refer to Multi-screen > Screen Sharing or Content Sharing in this manual.

**Note:**



- To use this function, make sure your TV and mobile device are connected to the same network environment.
- Enabling this function may result in higher energy consumption.

Related Topic

- Network Issues

## Connecting Bluetooth Devices

You can connect to devices using Bluetooth technology.



  >  Settings > Network > Bluetooth

**Note:**

- Bluetooth function may not be applicable in some models/countries/ regions.

## Connecting a Bluetooth remote

Pair the Bluetooth remote with the TV.



- Pair the Bluetooth remote to the TV after you power the TV on, and set   >  Settings > Network > Bluetooth to On.
- Keep the remote control within 3 metres from the TV. Press any button (except power and mic button) to pair with the TV.

**Note:**

- In special cases, press and hold / button to pair.
- This function may not be applicable in some models/countries/regions.
- If an unknown error occurred with the remote, it could have been caused by interference. Try to remove what's causing the interference and pair it again.
- If an unknown error occurred with the remote while the battery power is normal, you can take out the batteries, press any key for 1~2 seconds, and insert them back. Then the remote will work normally.
- The remote cannot be paired to the TV while the TV is in standby mode

**Connecting a Bluetooth device**

To pair a Bluetooth device, such as Bluetooth headphones, speakers, keyboards, mouse or even mobile devices:



1. Set   >  > Settings > Network > Bluetooth to On.
2. Before pairing your Bluetooth devices, make sure they're in pairing mode and put devices within pairing range. To put your Bluetooth devices in pairing mode, refer to the manual of devices.
3. Find the Bluetooth device name in / > Settings > Network > Bluetooth > Equipment Management and select it. The device will be automatically connected to the TV.

**Note:**

- Only one Bluetooth speaker or Bluetooth headphone can be connected to the TV. If a new Bluetooth speaker or headphone connects to the TV, the old one will be disconnected automatically.
- Compatibility issues may occur depending on the Bluetooth device.
- The TV and Bluetooth devices may disconnect depending on the distance between them.
- For more information about Bluetooth headphone settings, please refer to Picture and Sound > Using Headphones in this manual.

**Listening to the audio through Bluetooth devices**



Pair the Bluetooth audio devices using the TV's Bluetooth function. Refer to the user manual for your audio devices, such as Bluetooth speaker or sound bar, for detailed connection and usage.

After the Bluetooth connection is completed, go to   >  > Settings > Sound > Speakers > Audio Output, and then select BT Sound Bar option to listen to the audio through bluetooth devices.

**Note:**

- Compatibility issues may occur depending on the Bluetooth device.
- The TV and Bluetooth device may disconnect depending on the distance between them.

## TV Bluetooth speaker

  >  Settings > Network > Bluetooth > TV Bluetooth Speaker

TV Output: Mobile devices are connected to TV with Bluetooth. Sound outputs via TV speaker.

When your mobile device is connected to the TV via Bluetooth, you can play your mobile phone's music through TV built-in speakers. This function makes the TV perform as a speaker.

Go to your mobile Settings to enable Bluetooth, and choose the TV to connect.

To use this function, make sure to select TV Speaker at / > Settings > Sound > Speakers > Audio Output.

### Related Topic



- Speakers Settings

## Connecting Headphones

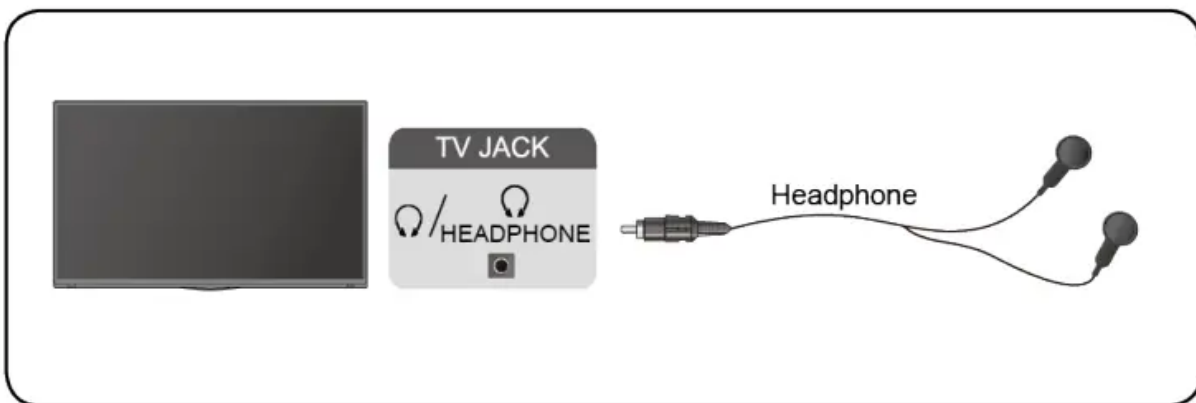
You can connect a pair of headphones (not provided) to the HEADPHONE port on your TV. While the headphone is connected, the sound from the builtin speakers will be disabled.



**Note:**

- Headphone port may not be available in some models.
- Headphones with microphones are not supported.
- If Headphone with Speakers is selected manually in   >  > Settings > Sound > Headphone > Headphone Mode, the headphone and the TV will have sound output at the same time.

- For more information about headphone settings, please refer to Picture and Sound > Using Headphones in this manual.

## Connecting USB Devices

Connect the USB devices, such as hard drives and USB sticks for browsing photos, or listening to music.

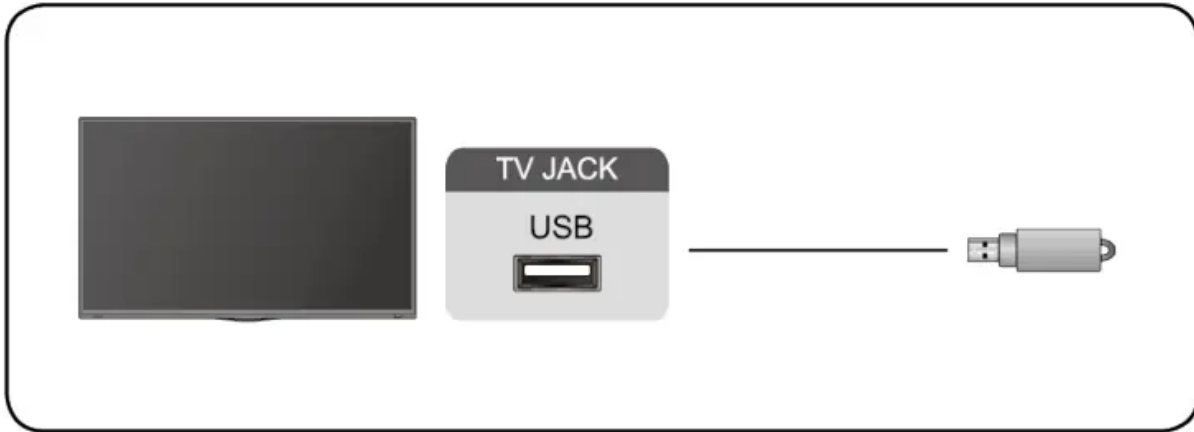

### Note:

- Support the USB disk 4G, 8G, 16G, 32G, 64G, 128G and other common market sizes, and 8T hard drive is currently supported.
- Support format: NTFS, FAT32.
- Select the content you want to play or view. For more information, please refer to Smart Functions > Media in this manual.

## Connecting an Antenna

You can connect an antenna cable to your TV.

Using your remote, select  Input icon in Home screen and select TV as the input source.

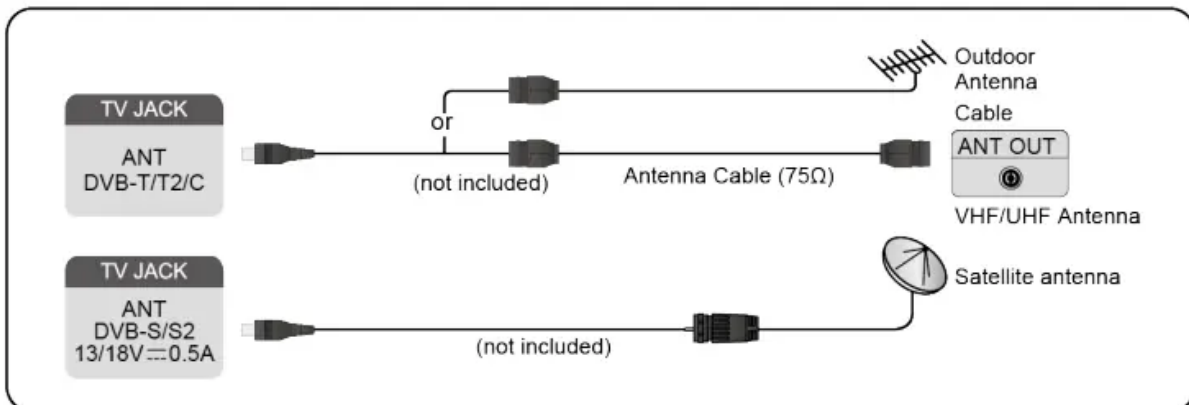

## Related Topic

- Channel Scan

## Connecting Audio Visual (AV) Devices

### Connecting with a composite video cable

To connect an AV device with a composite video cable (not provided), see the illustration below.

When the connection is finished, using your remote, select  Input icon in Home screen, and select **AV** as the input source.

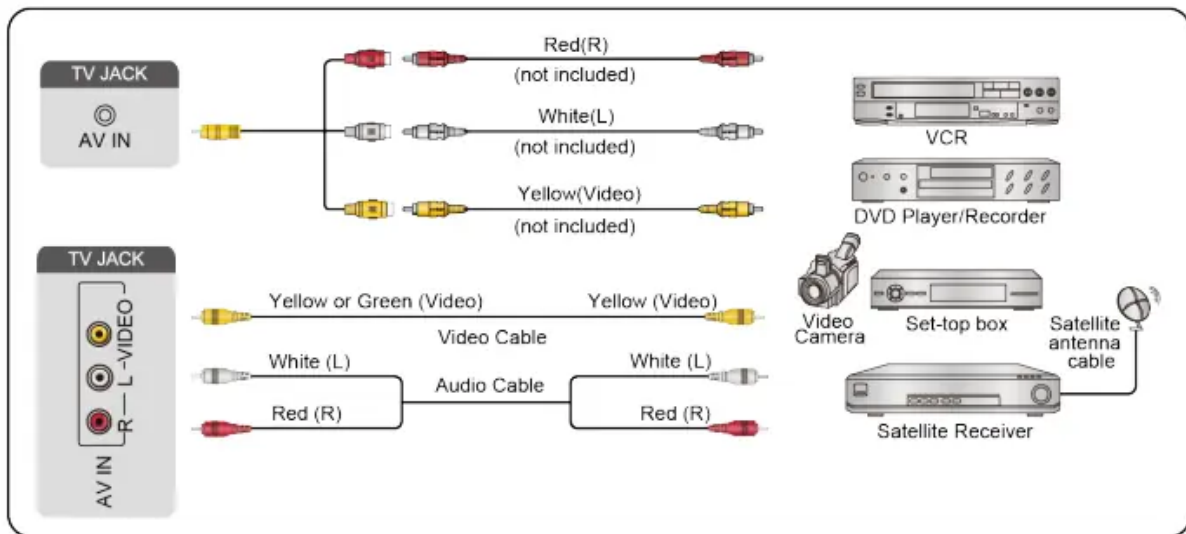

### Note:

- AV IN port(s) may vary depending on models.
- AV IN port(s) may not be available in some models. Please use other port(s) to connect AV devices.

### Connecting with an HDMI cable

To connect an AV device with an HDMI cable (not provided), see the illustration below.

When the connection is finished, using your remote, select the Input in Home screen, and select the corresponding HDMI input.

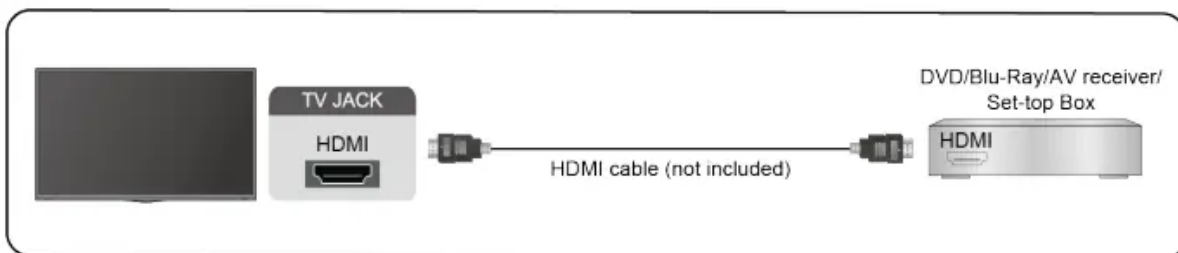

**Note:**

- Please refer to the User Manual that came with your device for step-by-step instructions.
- Some devices, such as DVD player, require HDMI signal to be set to output in the device's settings. Please consult your device's user manual for instructions.
- If there is no sound from your TV, configure the device's audio settings.

Related Topic

- Using HDMI & CEC

## Connecting Speakers or Other Audio Receivers

To connect speakers or other audio receivers with an audio cable (not provided), see the illustration below.



Plug the connected devices into the main power socket before switching on the TV.

When the connection is finished, go to   >  > Settings > Sound > Speakers > Audio Output, and select the SPDIF Only option.

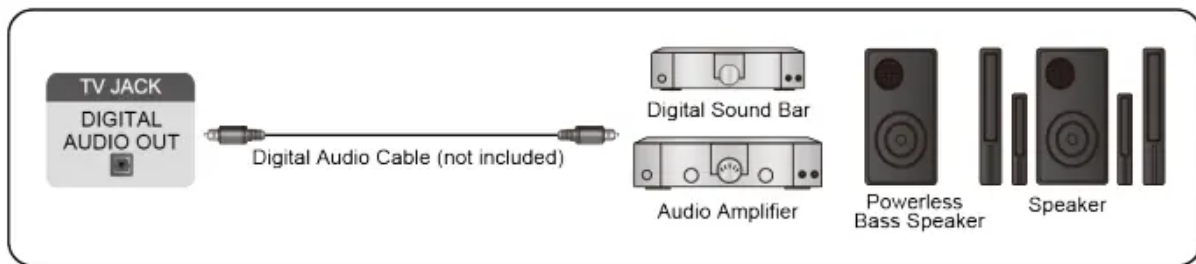
When a digital audio system is connected to the DIGITAL AUDIO OUT port, decrease the TV volume and your digital audio system volume.



**Note:**

- If you prefer to use Audio Return Channel/Enhanced Audio Return Channel, please refer to Connection > Connecting a Digital Audio System to Use ARC/eARC in this manual.
- You can connect the DIGITAL AUDIO OUT port on the back of the TV to the optical port on the amplifier. Then go to   >  > Settings > Sound > Speakers > Digital Audio Out to select Dolby Digital to receive the Dolby Digital audio.

Related Topic

- Speakers Settings





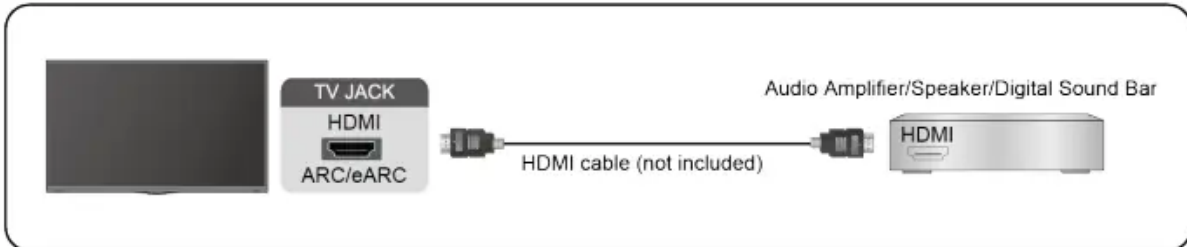

## Connecting a Digital Audio System to Use ARC/ eARC

If you'd like to use the Audio Return Channel (ARC)/the Enhanced Audio Return Channel (eARC) feature to send sound from the TV by an HDMI cable to a digital sound system, you can connect it to the HDMI (ARC/eARC) port of your TV.



By using this feature, you can also control the sound system with your TV remote instead of using the remotes for each device.



After the connection:

1. Power on the sound system.
2. Press   button to select  Settings icon in the Home screen.
3. Select Sound > Speakers > Audio Output, and select ARC option. If the device supports eARC function, press   button to select  Settings icon in the Home screen, and select Sound > Speakers > eARC to set eARC to On.

### Note:



- It works only when the TV is connected to the audio receiver that supports the ARC/ eARC function.
- If the device has an Input Selector feature, then make sure to change it to the TV.
- When this port is used for ARC/eARC function, it can be used as signal input when a DVD is connected to an amplifier and the amplifier is connected to the TV at the same time. Some amplifiers may not support series connection.
- 5.1 CH (channel) audio is available when the TV is connected to an external device that supports 5.1 channel surround sound. You can press   button to select  Settings icon in the Home screen, and select
- Sound > Digital Audio Out to choose Dolby Digital Plus to receive the 5.1 channel audio.

### Related Topic



- Speakers Settings

## Using HDMI & CEC

Use the TV remote to control external devices that are connected to the TV by an HDMI cable. The external devices need to support HDMI & CEC function.

  >  Settings > System > HDMI & CEC



### Connecting an external device through HDMI & CEC function

  >  Settings > System > HDMI & CEC > CEC Control

Allow HDMI devices to control each other.

1. Set CEC Control to On.
2. Connect an HDMI & CEC compatible device to the TV.
3. Turn on the connected external device. The device will be connected to the TV automatically. After connection is finished, you can access the menu of the connected device on your TV screen using your TV remote and control the device.

### Enabling device auto power off

  >  Settings > System > HDMI & CEC > Device Auto Power Off Set to On to turn off HDMI & CEC compatible external devices when the TV is turned off.



### Enabling device auto power on

  >  Settings > System > HDMI & CEC > Device Auto Power On

Set to On to turn on HDMI & CEC compatible external devices when the TV is turned on.



This feature is applicable when TV input source is preset to the corresponding external device.

### Enabling TV auto power on

  >  Settings > System > HDMI & CEC > TV Auto Power On

Set to On to turn on the TV when HDMI & CEC compatible external devices is turned on.

### HDMI format function

  >  Settings > System > HDMI & CEC > HDMI Format

Please select Enhanced format if your HDMI device supports 4K HDR. If it does not support 4K HDR, please select Standard format. If you are not sure, please select Auto.



#### Note:

- HDMI cables must be used to connect HDMI & CEC compatible devices to your TV.

- The HDMI & CEC feature of the connected device must be turned on.
- If you connect an HDMI device that is not HDMI & CEC compatible, all the
- HDMI & CEC control features do not work.
- Depending on the connected HDMI device, the HDMI & CEC control feature may not work.
- The HDMI & CEC feature supports One Touch Play, Routing Control, System Standby, Device OSD Name Transfer, Remote Control Pass Through, Give Device Power Status, System Audio Control.

## Connecting a PC or a Game Console PC

You can connect a PC to the TV with an HDMI cable to use your TV as a PC monitor.

After connecting the PC, press the   button, then select  Input icon in Home screen or press **INPUT** button. Select the connected PC as the input source.

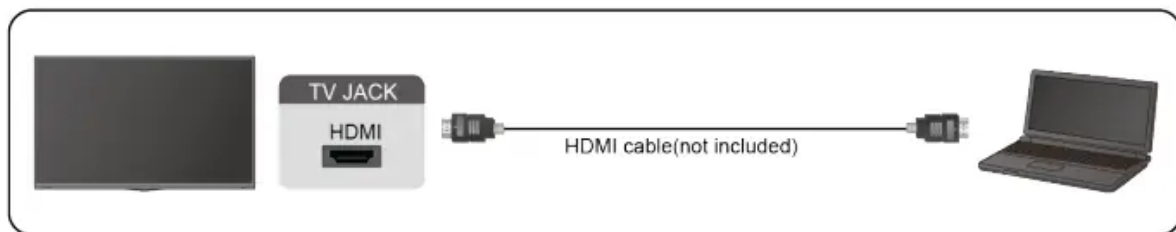



### Note:

- For better image quality, set the PC's resolution, and make sure the resolution is supported by the TV.
- If there is no sound from your TV, change the PC's audio settings.
- If you want to connect your PC and TV wirelessly, please refer to Multiscreen > Content Sharing in this manual.

## Game console

You can connect your game console with an HDMI cable to the TV.

To start a game from a game console:

1. Switch on your game console.
2. Press the   button, select  Input icon in Home screen or press **INPUT** button. Select the connected game console as the input source.
3. Start the game.

You can enable the game mode to optimise your TV's settings when playing games with a game console. For more information, please refer to Picture and Sound > Game Mode Settings in this manual.

## Picture and Sound

### Adjusting the Picture Quality

Adjust picture mode, picture size and other advanced picture settings.

### Choosing a picture mode



  >  Settings > Picture > Picture Mode

Select a preset picture mode to best suit the content you're viewing. Options may differ depending on models. Please refer to the actual product.

- Standard
  - Best suited for watching normal content, such as News, Drama or Documentary.
- Cinema day
  - Best suited for watching movies in a bright environment.
- Cinema night
  - Best suited for watching movies with dark environment.
- Dynamic
  - Best suited for the content that requires vivid picture quality.
- Sports
  - Optimized picture for watching sports.
- Auto
  - The picture mode will be adjusted automatically.



#### Note:

Auto mode may not be applicable in some models/countries/regions, and to use this function, you must choose Yes, Enable Enhanced Viewing in the Enhanced Viewing when you turn the TV on for

the first time, or at   >  > Settings > System > Advanced Settings > Enhanced Viewing. For more information, please refer to Accessibility and System > Enhanced Viewing in this manual.

## Low Blue Light

Cinema day and Cinema night are designed to reduce the level of blue light to protect your eyes.

Go to   >  > Settings > Picture > Picture Mode, and select Cinema day/Cinema night.

To reduce the eye strain and protect eyes when you watch TV for a period of time, you are suggested to:

- Take regular and frequent breaks to avoid watching TV for a long period of time. Long time of watching may cause you eye fatigue. It is not recommended to watch TV for more than one hour.
- Look away from the TV screen and look at distance objects during the breaks for at least 10 minutes for eye care.
- Relax yourself during a break by doing eye exercises or outdoor activities.
- The best recommended viewing distance is 3 times the vertical height of the TV screen.

Proper breaks and exercises are proved excellent help to relieve eye strain and fatigue.

This feature may not be applicable in some models/countries/regions.

## Enabling Smart Scene function

  >  Settings > Picture > Smart Scene

You can turn on the Smart Scene function, and enable your TV to continually recognize the scene in the content watching and enhance the picture quality on all input sources.



### Note:

- Some specific application has explicit constraints that the content recognition is not allowed.
- When Game Mode is turned on, Smart Scene will be switched off automatically and is not available to set.

## Troubleshooting









### Picture Issues

When the TV has a picture problem, these steps may help resolve the problem.

  >  Settings > Support > Self Diagnosis > Picture Test



Before you review the list of problems and solutions below, use Picture Test to determine if the problem is caused by the TV. Picture Test displays a high definition picture that you can examine for flaws or faults.

- If the test picture does not appear or there is noise or distortion, the TV may have a problem. Contact the service company in your country/region.
- If the test picture is displayed properly, there may be a problem with an external device. Please check the connections.
- If the problem persists, check the signal strength or refer to the external device's user manual.

Problem	Possible Solutions
<p>No picture, or black and white picture.</p>	<ul style="list-style-type: none"> <li>• Unplug the TV power cord from AC outlet and re-plug after 60 seconds.</li> <li>• Check if the Colour Saturation is set to 50 or higher at   &gt;  &gt; Settings &gt; Picture &gt; Picture Mode Settings &gt; Colour Saturation.</li> <li>• Try different TV channels.</li> </ul>
<p>The picture is distorted.</p>	<ul style="list-style-type: none"> <li>• The compression of video content may cause picture distortions, especially in fast moving pictures from sports programmes and action movies.</li> <li>• If the signal reception is weak or poor, screen distortion may be visible but it is not a malfunction.</li> <li>• Mobile phones used close to the TV (within 1m) may cause noise on analogue and digital channels.</li> </ul>
<p>The picture is blurry or flickering, or cuts out momentarily.</p>	<ul style="list-style-type: none"> <li>•   &gt;  &gt; Settings &gt; Picture &gt; Picture Mode Settings &gt; Sharpness. You can try to increase or decrease the Sharpness.</li> <li>• If you use an external antenna, check the direction, position and connection of the antenna.</li> <li>• Adjust the direction of your antenna, or reset or fine tune the channel.</li> </ul>
<p>The picture appears red, purple, pink and other colours.</p>	<ul style="list-style-type: none"> <li>•   &gt;  &gt; Settings &gt; Picture &gt; Picture Mode Settings &gt; Expert Settings &gt; White Balance. You can try to increase or decrease the White Balance</li> </ul>
<p>Picture distorted or appear wavy.</p>	<ul style="list-style-type: none"> <li>• Some electrical appliances may affect the TV. If you turn off the appliance and the interference goes away, then move it further away from TV.</li> <li>• Insert the power plug of the TV into another power outlet.</li> </ul>

## Sound Issues

When the TV has a sound problem, these steps may help resolve the problem.



  >  > Settings > Support > Self Diagnosis > Sound Test

If the TV plays the Sound Test melody without distortion, there may be a problem with an external device or the broadcast signal's strength.



Problem	Possible Solutions
There is no sound or the sound is too low at maximum volume.	<ul style="list-style-type: none"><li>• Check the volume control of the device (cable or satellite box, DVD, Blu-ray, etc.) connected to your TV.</li></ul>
Picture is normal, but no sound.	<ul style="list-style-type: none"><li>• Check the volume settings.</li><li>• Check if 'Mute' mode is set to on.</li></ul>
The speakers are making an odd sound.	<ul style="list-style-type: none"><li>• Make sure that the audio cable is connected to the correct audio output connector on the external device.</li><li>• For antenna or cable connections, check the signal information.</li><li>• A low signal level may cause sound distortions.</li></ul>
Sound distorted or appears wavy.	<ul style="list-style-type: none"><li>• Some electrical appliances may affect the TV. If you turn off the appliance and the interference goes away, then move it further away from TV.</li><li>• Insert the power plug of the TV set into another power outlet.</li></ul>
Sound is blurry or cuts out momentarily.	<ul style="list-style-type: none"><li>• If you use an external antenna, check the direction, position and connection of the antenna.</li><li>• Adjust the direction of your antenna or reset or fine tune the channel.</li></ul>

## Network Issues

When the TV has difficulties in connecting to the Internet, these steps may help resolve the problem.

  >  > Settings > Support > Self Diagnosis > Network Test

If the TV network is connected, the screen will display Connected successfully.

Problem	Possible Solutions
The TV cannot connect to your network or apps.	<ul style="list-style-type: none"> <li>• Make sure the TV has a network connection.</li> <li>• Run   &gt;  &gt; Settings &gt; Support &gt; Self Diagnosis &gt; Network Test.</li> <li>• Contact your Internet service provider.</li> </ul>
The wireless network connection failed.	<ul style="list-style-type: none"> <li>• Make sure your wireless modem/router is on and connected to the Internet</li> </ul>
The wireless network signal is too weak.	<ul style="list-style-type: none"> <li>• Position your wireless router, modem router, or access point in a central location. Avoid putting it in a corner.</li> </ul>



## External Device Connection Issues

When the TV has difficulties with external device connection, these solutions may help resolve the problem.







### I have connected an external source to my TV but I get no picture and/or sound.

- Check whether the connection between the external device and your TV is correct.
- Make sure you have made the correct selection of input source.

### The cable box is no signal or weak signal.

- If there is no signal occasionally, unplug cable from TV and re-plug after 60 seconds.
- If there is always no signal, or the signal cannot be restored after plugging and unplugging, you can try   >  > Settings > System > HDMI & CEC > HDMI Format, to confirm whether the signal can be recognized.
- Change to another HDMI port.
- Change to another HDMI cable.

### There is no sound.

- Check whether ARC is selected at   >  > Settings > Sound > Speakers > Audio Out. If not, you need to check whether the external power amplifier device is connected to the ARC/eARC port or optical port of the TV.
-   >  > Settings > Sound > Speakers > Digital Audio Out. You can try to select PCM, Dolby Digital, or Dolby Digital Plus.
- Whether the power amplifier device port is connected correctly.

- If you select HDMI as input, you can try / > Settings > System > HDMI & CEC > HDMI Format.







### **The remote control does not work.**

- Confirm that TV still has power and is operational.
- Change the new batteries in the remote control.
- Check if the batteries are correctly installed.
- If some buttons don't work, but the volume buttons can work normally, it seems there is a problem with the application.

## **Apps**

When some apps aren't playing, this may help resolve the problem.

### **Netflix can't be played.**

-   >  > Settings > System > Application Settings > Netflix > Forced Closure, then reopen to try.
- You can try to reset to the factory settings at   >  > Settings > Support > Reset to Factory Default.

## **Media Files**

When files aren't playing, this may help resolve the problem.

### **Some files can't be played.**

- Most files can be played back, but you might experience problems with corrupted files or files with high-bitrate, unsupported resolution, unsupported container or codec formats.

### Related Topic

- Media

## **Voice Service Issues**

When some Voice service aren't playing, this may help resolve the problem.

### **Alexa can't be played.**

- For more information about Alexa, please refer to Smart Functions > Using Voice Service > Alexa in this manual.

### **Google assistant can't be played.**

- You can try to log in Google account.

- If you receive "I don't understand" of the voice recognition, please change account or log out the account.
- After logging in to the Google account, the recognition language may be different. You need to log in to the Google account on the web page to set the voice language.
- For more information about Google Assistant, please refer to Smart Functions > Using Voice Service > Google Assistant in this manual.

## TV Status Diagnosis



> Settings > Support > Self Diagnosis Perform self diagnosis to test sound, picture and connections.

Use Picture Test to help diagnose video issues and Sound Test to diagnose sound issues. You can also view signal strength information for over-the-air digital signals by using Network Test and Input Connection Test. Additionally, you can view the status of the TV by using Status Check.

## Recording/Timeshift Issues

When Timeshift or Schedule recording isn't working, these steps may help resolve the problem

### Schedule Recording cannot be used.

- Check if there is a storage device connected to the TV.
- Check the free space of the storage device. The function will not work if there isn't enough storage space in the device.
- Check whether your storage device is damaged. If so, it is suggested to format your storage device.
- Recording will automatically stop if the signal becomes too weak.
- Recording or timeshift function may not work because of the slow speed of read-write for USB flash drive.
- Recording or timeshift function may not work because the storage format of your device is unsupported.
- The Recording/Timeshift functions may not be applicable in some models/ countries/regions.

### Related Topic

- PVR
- Timeshift

## Other Issues

Use these procedures to resolve other issues that may occur.

**The TV is hot.**

- Watching TV for an extended period of time causes the panel to generate heat. The heat from the panel is dissipated through internal vents running along the top of the TV.
- After extended use, you may feel hot when touching it. This heat, however, is not a defect and does not affect the TV's functionality.

**The TV smells of plastic.**

- This smell is normal and will dissipate over time.

**The plastic cabinet makes a "clicking" type of sound.**

- The "clicking" sound can be caused when the temperature of the TV changes. This change causes the TV cabinet to expand or contract, which makes the sound. This is normal and the TV is OK.

**When I turn on my TV, there is a delay for a few seconds before the picture appears. Is this normal?**

- Yes, this is normal. The TV is initializing and searching for previous setting information.

**Warning**

This content is compiled from multiple sources and is provided for reference purposes only. It may not be complete or fully applicable to all situations. If you are unable to resolve your issue, please contact the product manufacturer or an authorized service provider for official support.