

INSTALLATION

Parts and Specifications

NOTE

- Appearance and specifications may vary without notice to improve the quality of the appliance.

Front View

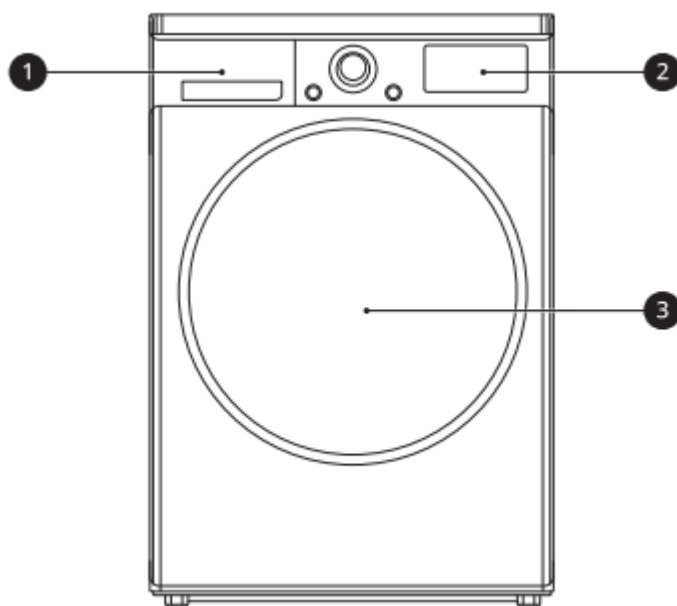

1. Water Container
2. Control Panel
3. Door

Available Accessories

Please contact LG Electronics Customer Information Centre

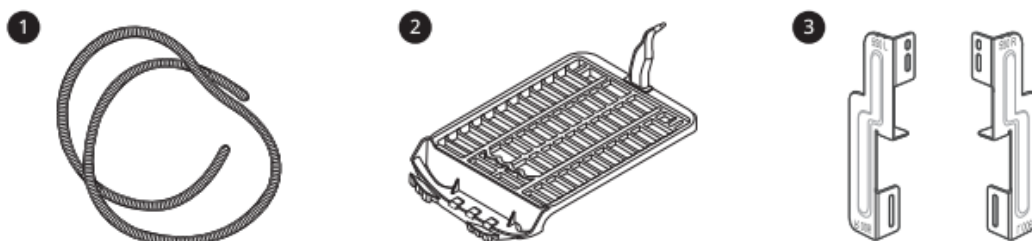

1. Condensing Drain Hose and Hose Holder

2. Dry Rack
3. Stacking Kit

NOTE

- The included accessories vary depending on the model you purchased.

Specifications

Asterisk(s) means model variant and can be varied (0-9) or (A-Z).

Model	FDV309W
Power supply	220 - 240 V~, 50 Hz
Dimension (Width X Depth X Height)	600 mm X 690 mm X 850 mm
Product weight	56 kg
Allowable temperature	5 - 35 °C

Installation Place Requirements

Before installing the appliance, check the following information to make sure that the appliance should be installed in a correct place.

Installation Location

WARNING

- Do not install the appliance around a heat source. The rear side of the appliance must be well ventilated. Failure to follow these instructions may result in problems.
- The appliance is not designed for maritime use or for use in mobile installation such as caravans, aircraft and etc.
- Do not install the appliance as a built- in appliance. It is not suitable for built- in purpose.

NOTE

- For better drying performance, keep the rear of the appliance away from the wall.
- Make sure that the location where the appliance will be installed meets a minimum clearance conditions.
- Install the appliance on a flat hard floor. Allowable slope under the appliance is 1 degree.



- Never try to correct any unevenness in the floor with pieces of wood, cardboard or similar materials under the appliance.
- Install the appliance in a location where service engineers are easily accessible in the event of a breakdown.
- Do not install the appliance next to high-temperature appliances such as refrigerator, oven or stove, and etc. It can cause poor drying performance and delay programme duration. It also adversely affect the proper functioning of the compressor.
- Do not install the appliance where there is a risk of frost or dust. The appliance may not be able to operate properly or may be damaged by freezing of condensed water in the pump and drain hose.
- With the appliance installed, adjust all four feet using a spanner to ensure the appliance is stable, and a clearance of approximately 20 mm is left between the top of the appliance and the underside of any work-top.

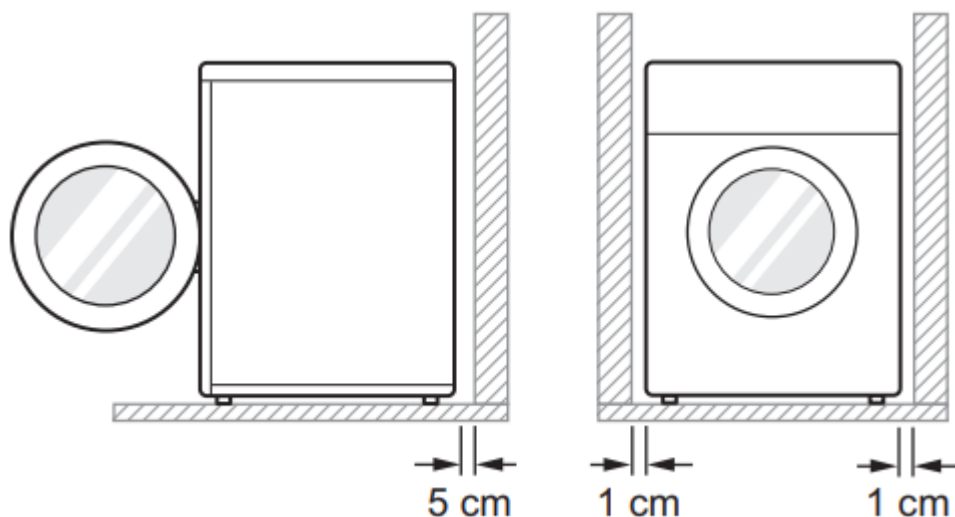

Ventilation

- Alcove or under counter
 - Ensure airflow of 3.17 m³/mm through the appliance.
- Cupboard
 - Cupboard door must have 2 (louvered) opening, each have a minimum area of 387 cm², located 8 cm from bottom and top of the door.

NOTE

- Make sure that air circulation around the appliance is not impeded by carpets, rugs, and etc.

Ambient Temperature

- Do not install the appliance in rooms where freezing temperatures may occur. Frozen hoses may burst under pressure. The reliability of the electronic control unit may be impaired at temperatures below freezing point.

NOTE

- If the appliance is delivered in winter and temperatures are below freezing, place the appliance at room temperature for a few hours before putting it into operation.
- The appliance performs best at a room temperature of 23 °C.

Electrical Connection

- Do not use an extension cord or double adapter.
- Do not overload the outlet with more than one appliance.
- Connect the appliance to an earthed socket in accordance with current wiring regulations.
- The appliance must be positioned a place close to outlet socket so that the plug is easily accessible.
- Outlet socket must be within 1.5 meters of either side of the location of the appliance.

NOTE

- Always unplug the appliance after use.

Leveling the Appliance

Checking Leveling

Leveling the appliance prevents unnecessary noise and vibration. Check whether the appliance is perfectly level after installation.

- If the appliance rocks when pushing the top plate of the appliance diagonally, adjust the feet again.

NOTE

- Timber or suspended type flooring may contribute to excessive vibration and unbalance. Reinforcement or bracing of the timber floor may need to be considered to stop or reduce excessive noise and vibration.
- Do not install the appliance on any elevated surface, stand or plinth as it can become unstable and fall causing serious injury and damage.

Adjusting and Leveling the Appliance

When the appliance is not perfectly level, turn the adjustable feet until the appliance no longer wobbles.

- Turn the adjustable feet clockwise to raise or turn the adjustable feet counterclockwise to lower from front- to-back, side-to-side and corner-to- corner.

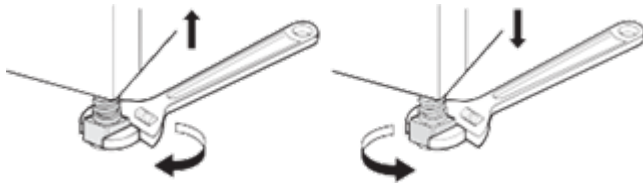

Reversing the door

You can reverse the door for your convenience.

WARNING

- Do not reverse the door while the appliance is stacked on a washing machine.
- Before removing the hinge screws, have an assistant support the weight of the door. The door could fall on the floor due to the weight of the door.
- For safety reasons, two or more people need to work together to reverse the door.

NOTE

- The appearance of the screws varies and the screws must be inserted differently depending on the position. Make sure the screw is properly selected before tightening.

1 Open the door and remove 2 screws on the door hinge 1. After removing the screws, put the door down carefully from the cabinet 2 with the front side facing down to the floor.



2 Remove 8 screws on the hinge assembly 3 from the door.

- There are 6 screws on the front and 2 screws on the side.

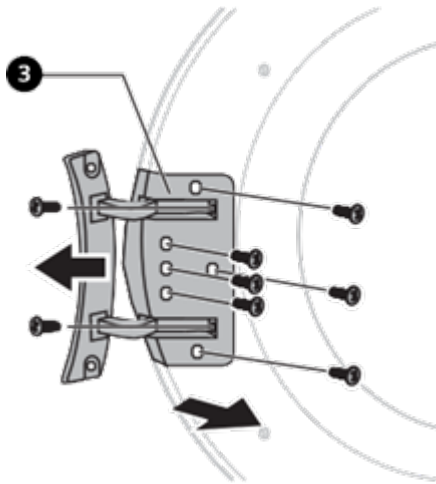

3 Remove the 3 screws from the door latch assembly 4 which is fixed between the door and the hinge assembly, and then remove the screw which is fixed on the door hook.

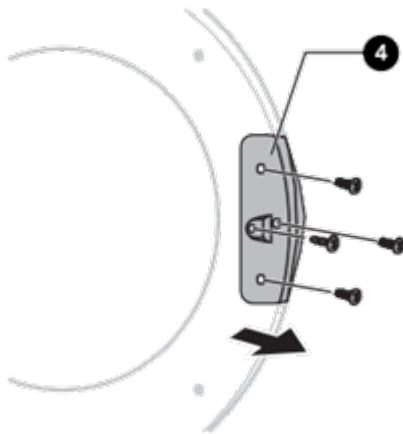

4 Swap the position of the hinge assembly 3 and the door latch assembly 4 and then tighten the screws in reverse order.

- Tighten the screw in their proper position referring from steps 2 to 4.

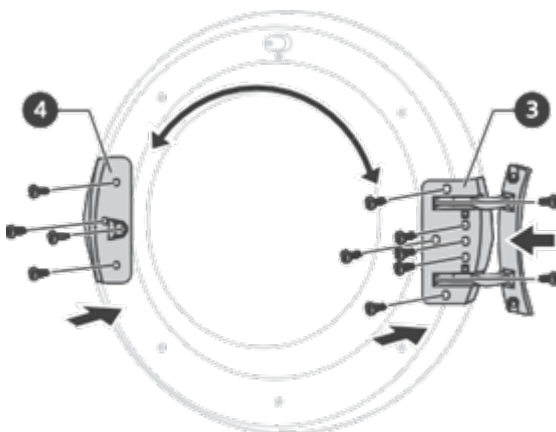

5 Remove the door catch 5 from the appliance frame by removing 2 screws and then assemble them on the opposite side.

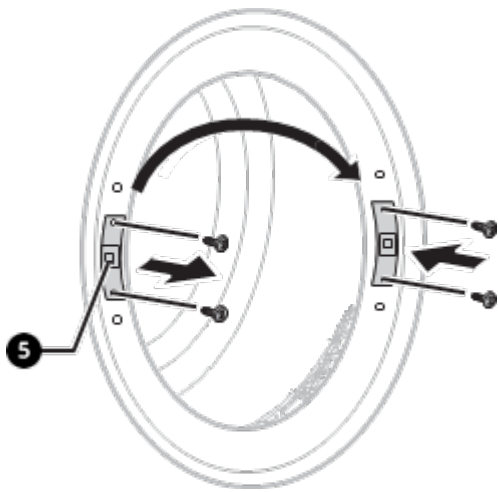

6 Remove the 2 decorative screws from the appliance frame and then assemble them on opposite side.

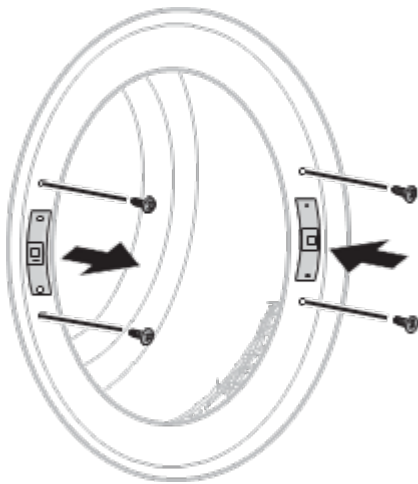

7 Install the door with the screws removed in step 1 and then check the door closes properly.

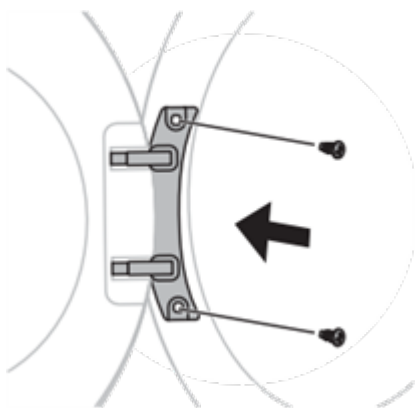

OPERATION

Operation Overview

Using the Appliance

Before the first cycle, set the appliance to dry for 5 minutes to warm up the drum. Open the door between loads the first few times you use the appliance to allow any odours from the interior of the appliance to disperse.

Children must be supervised so that they do not climb inside the drum.

1 Ensure the lint filter and water container are clean.

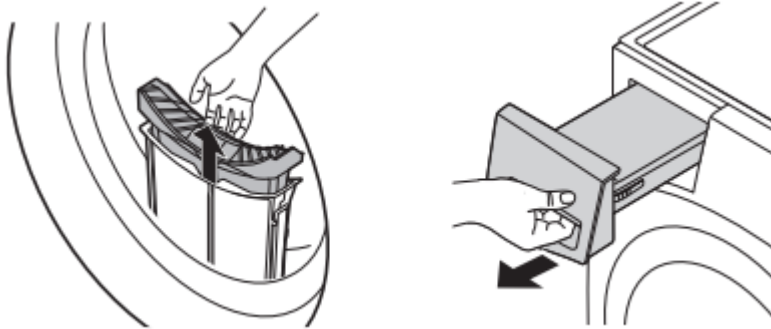

- Open the door and ensure the lint filter is clean. When the filter is full with lint, drying times will be longer than usual.
- Pull out the water container and empty the condensed water. When the water container is full, the appliance may stop during the cycle.

NOTE

•In some instance, LED window may display E icon to inform you that the water container is full. If this occurs, empty the water container.

2 Place the clothes into the drum after sorting and close the door.

- Push the clothes deep into the drum so that the clothes keeps away from the door seal. When the clothes get stuck between the door and seal, they may get damaged while drying.
- The clothes should be sorted by fabric types and dryness level.
- All strings and attached belts of clothes should be well tied and fixed before being put into the drum.

3 Press the **Power** button to turn the appliance on.

- Depending on the models, the **Power** button may light up to indicate that the appliance is ready for dry.



4 Choose a drying programme by turning the programme selector knob.

•If you press the **Start/Pause** button without choosing a programme, the appliance will proceed with the **Cotton** programme. Please refer to the programme table for the detailed information.



5 Press the **Start/Pause** button to start the drying programme.

•When you press the button, the appliance ventilates the inside of the drum for 10 seconds in order to get the appliance ready for drying operation.



6 After the drying programme has finished, open the door and unload the clothes.

7 Press the **Power** button to turn the appliance off.

8 Clean the lint filter and empty the water container.

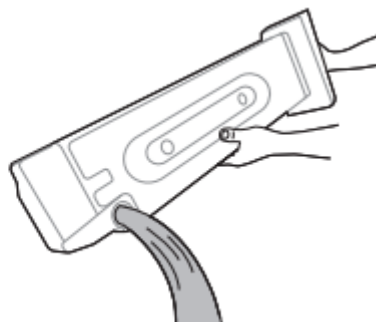

9 To help reduce odours from forming, the dryer's door can be left open or slightly ajar for a short period of time if possible to help ventilate the drum after use.

Preparing the Clothes

Checking the clothes before loading

- Observe the maximum load capacity on the programme table for the relevant drying programme to get optimum drying results. Overloading gives a poor drying result and causes unnecessary creasing.
- Do not load soaking wet clothes into the appliance. It will cause an increasing of drying time and energy consumption. Make sure that the clothes are spun thoroughly before loading.
- A mixed fabric load can cause the drying time to be extended and the time remaining in the display to pause during active drying. The remaining time will then continue when it is the actual time that remains.
- Make sure to empty all pockets. Items such as nails, hair clips, matches, pens, coins and keys can damage both your appliance and clothes.
- Remove loose belts and close zippers, hooks and strings to make sure that these items do not snag other clothes.

Sorting the Clothes

Clothes have their own fabric care labels, so drying according to the fabric care label is recommended.

Sort the clothes into size and type of fabric and then prepare the clothes according to the symbols on the fabric care labels.

Woollens

- Dry woollens on the **Wool** programme. Be sure to follow fabric care label symbols first. Wool may not be completely dried from the cycle, so do not repeat drying. Pull woollens to their original shape and dry them flat.

Woven and Loopknit Materials

- Some woven and loopknit materials may shrink, depending on quality.

Non-Iron and Synthetics

- Do not overload the appliance. Take out non-Iron items as soon as the appliance stops to reduce creases.

Baby Clothes and Night Gowns

- Always check fabric care labels.

Rubber and Plastics

•Do not dry any items made from or containing rubber or plastics such as:

-Aprons, Bibs and Chair Covers

-Curtains and Table Clothes







-Bathmats

Fiberglass

•Do not dry fiberglass items in the appliance. Glass particles left in the appliance may be subsequently picked up by your clothes in later cycles.

Checking the Fabric Care Label

The symbols on the fabric care label tell you about the fabric content of your clothes and how it should be dried.

Symbol	Description
	Dry
	Tumble Dry
	Permanent Press / Crease Resistant
	Gentle / Delicate
	Do not Tumble Dry
	Do not Dry

	High Heating
	Medium Heating
	Low Heating
	No Heating / Air
	Line Dry / Hang to dry
	Drip Dry
	Dry Flat
	In the Shade

Control Panel



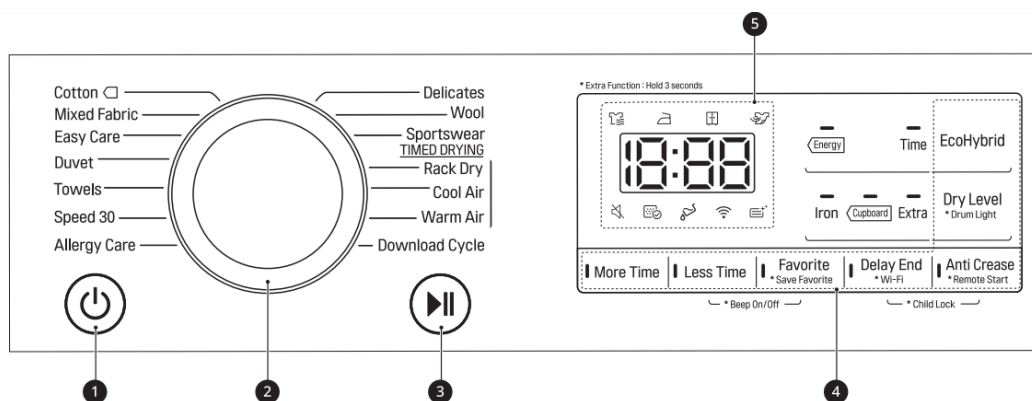

Control Panel Features



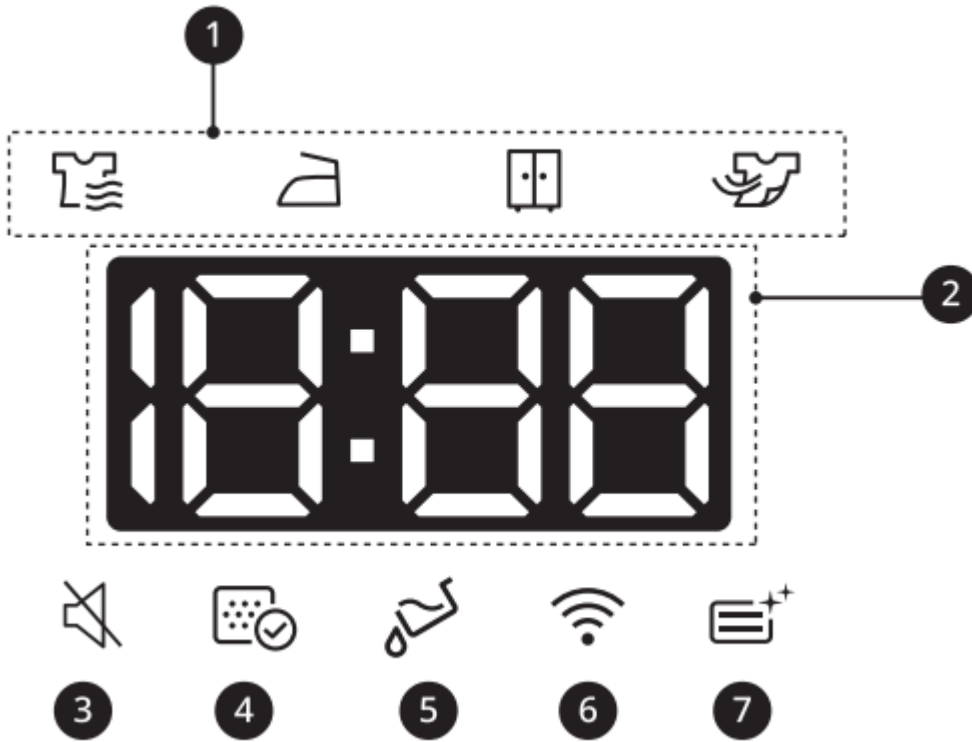



	Description
1	<p>Power On/Off button</p> <ul style="list-style-type: none"> • Press the Power button to turn power on and off. • Press the Power button to cancel the Delay End function.
2	<p>Programme Selector</p> <ul style="list-style-type: none"> • Programmes are available according to the clothing type. • The lamp will light up to indicate the selected programme.
3	<p>Start/Pause Button</p> <ul style="list-style-type: none"> • This Start/Pause button is used to start or pause a dry cycle. • When in Pause, the power is turned off automatically after 14 minutes for safety reasons.
4	<p>Extra Options and Functions / Additional Programme Buttons</p> <ul style="list-style-type: none"> • Use these buttons to select the desired options for the selected programme. Not all options are available in each programme. <p>Remote Start</p> <ul style="list-style-type: none"> • With the LG ThinQ app, you can use a smartphone to control your appliance remotely. • In order to use the Remote Start function, refer to SMART FUNCTIONS. <p>Wi-Fi</p> <ul style="list-style-type: none"> • Press and hold Delay End button for 3 seconds to initiate the connection of the appliance to the LG ThinQ application.
5	<p>Time and Status Display</p> <ul style="list-style-type: none"> • The display shows the settings, estimated remaining time, options, and status messages. When the appliance is turned on, the default settings in the display will illuminate.

Time and Status Display



	Description
1	<p>Drying progress indicator</p> <ul style="list-style-type: none"> •  lights up when the appliance is in drying progress. •  lights up when the appliance is in iron drying progress. •  lights up when the appliance is in cupboard drying progress. •  lights up when the appliance is in cooling progress.

	Description
2	<p>Time Remaining Display</p> <ul style="list-style-type: none"> •When a drying programme is selected, drying time for the selected programme is displayed. This time will change when you set the extra options for the programme. •Error messages will appear when the appliance diagnose problems.
3	<p> lights up when the Beeper function is turned off.</p>
4	<p> lights up when the lint filter should be cleaned or is inserted.</p> <ul style="list-style-type: none"> •Cleaning notice: When you press the Power button, the icon will become displayed. •Missing notice: When the lint filter is not inserted, the icon will become displayed and the appliance will not operate.
5	<p> lights up when the water collection tank needs to be emptied or is full.</p> <ul style="list-style-type: none"> •Emptying notice: When you press the Power button, this icon will become displayed. •Full water notice: The icon will become displayed and a chime will sound while the appliance is in operation.
6	<p> lights up when the appliance is connected to Wi-Fi network at home.</p>
7	<p> lights up while the condenser is being washed.</p>

Option Programmes and Extra Functions

Delay End

It allows you to delay the finishing time of the drying cycle from 3 hours to 19 hours.

- 1 Turn the appliance on.

- 2 Select a programme.
- 3 Press the **Delay End** button.
- 4 Set time delay hour(s) by pressing the **More Time, Less Time** button.
- 5 Press the **Start/Pause** button.

Anti Crease

It allows you to reduce creases that are formed when the clothes are not unloaded promptly at the end of drying cycle.

When the option is turned on, a lamp indicated that the anti crease option is set, lights up and the appliance repeatedly runs for 10 seconds and pauses for 5 minutes. The option is turned off automatically after 2 hours at the end of drying cycle.

To turn off the option, press the **Anti Crease** button before you start a drying cycle.

Dry Level

It allows you to select a dryness level for the drying programme.

- 1 Turn the appliance on.
- 2 Select a programme.
- 3 Select a dryness level by pressing the Dry Level button repeatedly

Beep On/Off

It allows you to turn the chime sound on and off. Press and hold the **Less Time** and **Favorite** buttons for 3 seconds at the same time.

- The LED lights up when the option is turned on.

EcoHybrid

It allows you to offer the option of saving energy or time.

- Energy:** Energy saving option.
- Time:** Time saving option.

Favorite

It allows you to store or recall a customized dry programme for future use.

How to save your favourite programme

1. Turn on the appliance.
2. Select a drying programme and set an option programme or extra functions. (Anti Crease, Dry Level, etc.)
3. Press and hold the Favorite button for 3 seconds.
4. Press the Start/Pause button to start the customized drying programme.

How to recall your favourite programme

- 1 Turn on the appliance.
- 2 Press the **Favorite** button.
- 3 Press the **Start/Pause** button to start the customized drying programme.

Drum Light

While the appliance is running, it is possible to see inside the drum when you turn the function on.

To turn the function on or off, press and hold the **Dry Level** button for 3 seconds.

- Light on:** Door is opened.
- Light off:** Door is closed.

More Time / Less Time

It allows you to increase or decrease drying time when you use manual drying programmes such as **Rack Dry**, **Cool Air** and **Warm Air**.

- Press the **More Time** button to increase the selected programme time by 5 minutes.
- Press the **Less Time** button to decrease the selected programme time by 5 minutes.

Child Lock

It allows you to control the locking and unlocking of control panel. It prevents children from changing cycles or operating the appliance.

Locking the Control Panel

- 1 Press and hold the **Anti Crease** and **Delay End** button simultaneously for 3 seconds.
 - 2 A chime will sound, and CL will appear on the display.
- When the function is activated, all buttons are locked except for the **Power** button.

Unlocking the Control Panel

Press and hold the **Anti Crease** and **Delay End** button simultaneously for 3 seconds.

- A chime will sound and the remaining time for the current programme will reappear on the display.

Rack Dry

This programme is designed for use with clothes that must be dried flat, without tumbling, including sweaters and delicate fabrics.

To use the programme, you need a dryer rack that is placed inside the appliance. Before drying, discard packing materials of the dryer rack.

- 1 Open the door.
- 2 Insert the hook of dryer rack to the drum centre.

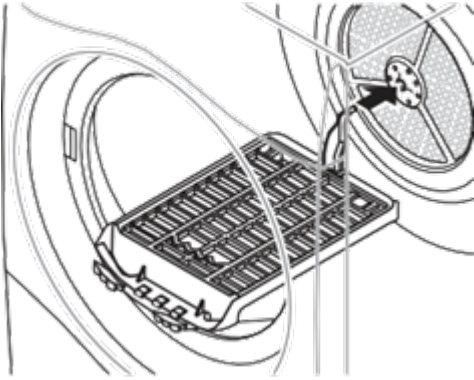

3 Place the dryer rack on the structure above the lint filter and press it to complete assembly.

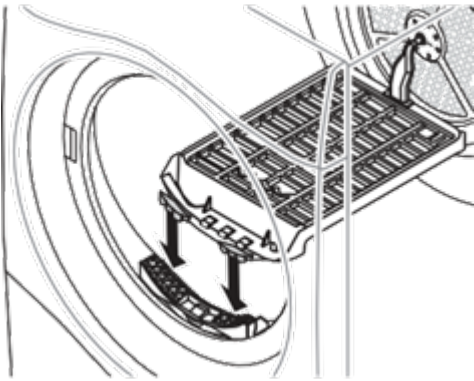

4 Place wet items on top of the rack. Allow space around items for air to circulate.

- The dryer rack does not move, but the drum will rotate.

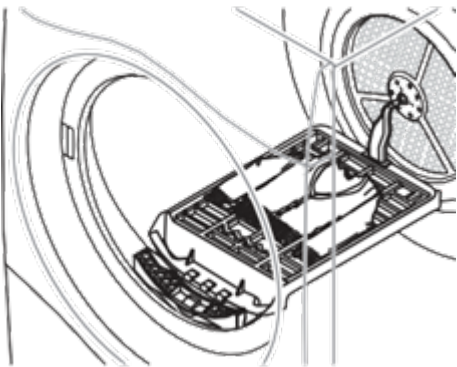

5 Close the door.

6 Turn power on and select **Rack Dry**.

7 Press the **Start/Pause** button.

MAINTENANCE

Cleaning after Every Dry

Cleaning the Lint Filter

CAUTION

- Clean the lint filter in the proper way referring to the following instructions. Failure to do so, the lint that is accumulated on the heat exchanger may not be cleaned properly.

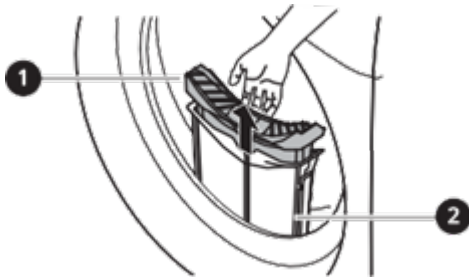

1 Inner Filter

- Always clean the inner filter before and after use.

2 Outer Filter

- Clean the outer filter after drying 10 times or when the lint is accumulated into the outer filter.

Clean the inner filter

1 Pull out the inner filter from the outer filter and then open the inner filter.

- Open the filter by unfolding it in the direction of the arrow.

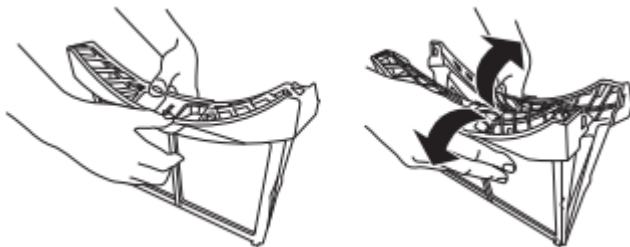

2 Clean a large cluster of lint first, then clean the residual lint using vacuum cleaner or washing under running water.

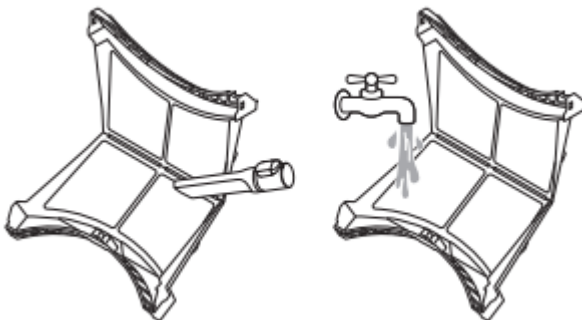

- Dry the filter completely if the filter is moist. Failure to do so, odour may occur in the appliance.

3 After drying the inner filter completely, close the filter by pushing down its center.

- Ensure the left and right side of the inner filter is closed properly.

4 Insert the inner filter into the outer filter.

Clean the outer filter

1 Remove the dust or lint around the filter inlet.

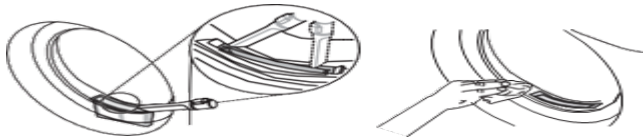

2 Pull out the outer filter.

3 Remove the inner filter.

4 Open the outer filter by unfolding in the direction of the arrow grasping the top edge of the outer filter.

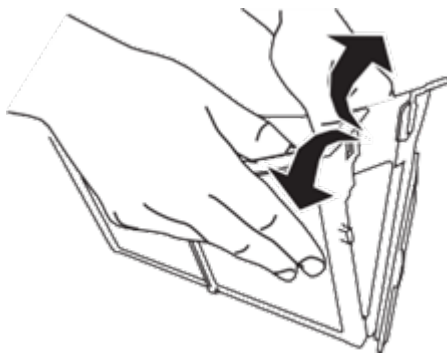

5 Clean the residual lint using vacuum cleaner or washing under running water.

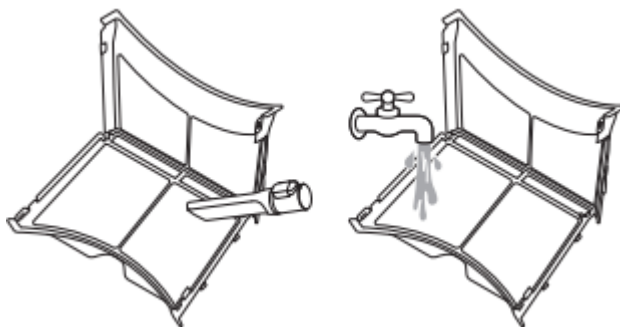

- Dry the filter completely if the filter is moist. Failure to do so, odour may occur in the appliance.

6 Close the outer filter while pushing the side a of the filter.

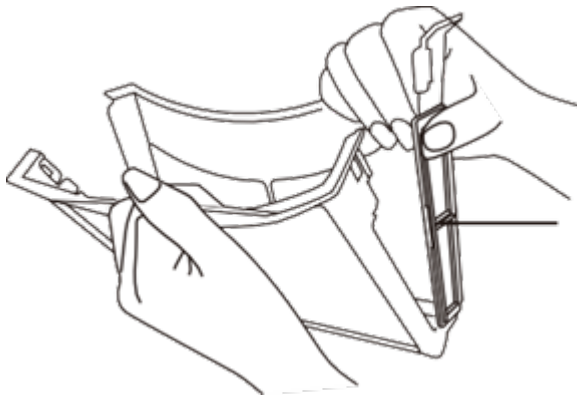

7 Close them, and reinsert the both lint filters.

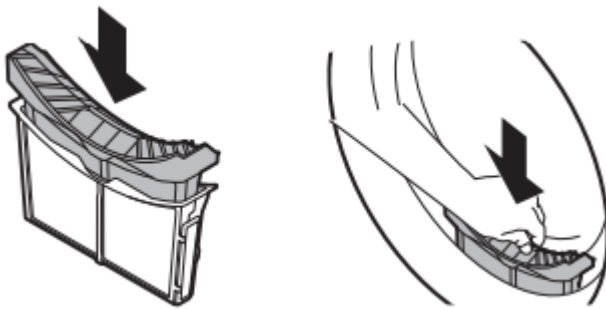

Emptying the Water Container

Condensed water is collected in the water container.

Empty the water container after every use. Not doing so will affect the drying performance.

NOTE

- If the water container is full, the E icon glows and a chime will sound while the appliance is operating. If this should occur, the water container needs to be emptied within the next hour.
- When the condensed water is drained out directly through the optional drain hose, there is no need to empty the water container.

1 Pull out the water container.

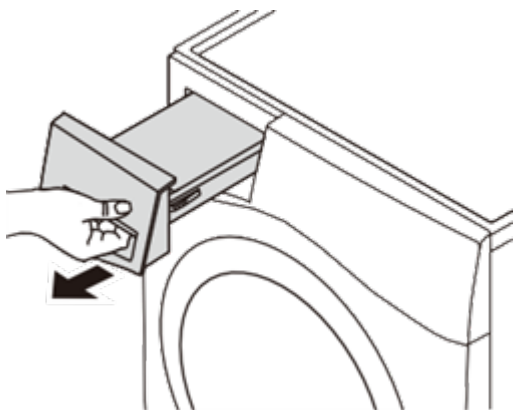

2 Empty the water container into the sink.

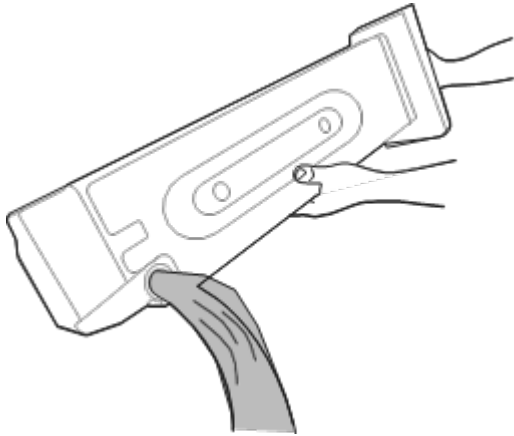

3 Refit it back into the appliance.

- Push in the water container fully into the appliance until it is in place.

4 Press the **Start/Pause** button.

Cleaning the Appliance Periodically

Wiping the Moisture Sensor

This device senses the moisture level of the clothes during operation, which means it must be cleaned regularly to remove any build-up of lime scale on the surface of the sensor.

Wipe the sensors inside the drum.

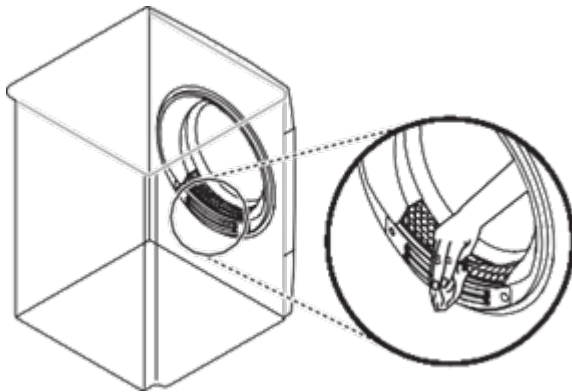

Cleaning the Cool Air Inlet Grill

Vacuum the cool air inlet grill 3 - 4 times a year to make sure there is no build up of lint or dirt that may cause improper air flow.

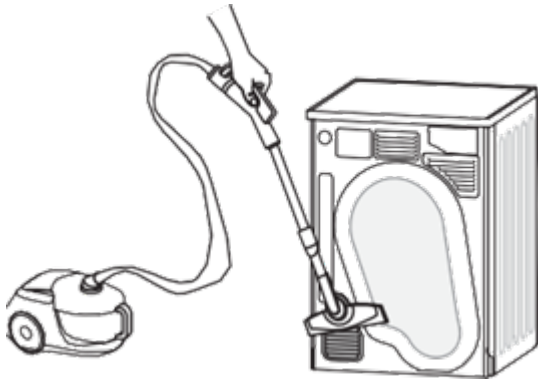

NOTE

- Warm air is expelled through the ventilation grill.
- Adequate room ventilation should be provided to avoid the back flow of gases into the room from units burning other fuels, such as open fires.

TROUBLESHOOTING

Operation of your appliance can lead to errors and malfunctions. The following tables contain possible causes and notes for resolving an error message or malfunction. It is recommended to read the tables carefully below in order to save your time and money that may cost for calling to LG Electronics service centre.

Before Calling for Service

Your appliance is equipped with an automatic error-monitoring system to detect and diagnose problems at an early stage. If the appliance does not function properly or does not function at all, check the following tables before calling to LG Electronics service centre.

Error Messages

Symptoms	Possible Cause & Solution
<p>dE DOOR ERROR</p>	<p>The door has been opened while the appliance is in operation or the appliance is being operated without the door being closed properly.</p> <ul style="list-style-type: none"> •Close the door completely. •If is not released, call for service.
<p>dE4 DOOR ERROR</p>	<p>Door switch detection is not working properly.</p> <ul style="list-style-type: none"> •Unplug the power plug and call for service.
<p>EE 1 / EE2 / EE4 TEMPERATURE ERROR</p>	<p>Temperature Sensor has malfunctioned.</p> <ul style="list-style-type: none"> •Unplug the power plug and call for service.
<p>F1 TEMPERATURE ERROR</p>	<p>The temperature inside the drum has risen suddenly.</p> <ul style="list-style-type: none"> •Unplug the power plug and call for service.
<p>LE1 MOTOR LOCKED ERROR</p>	<p>The motor has stopped suddenly.</p> <ul style="list-style-type: none"> •Check if the amount of clothes exceeds the maximum load capacity. •Unplug the power plug and call for service.
<p>LE2 / AE COMPRESSOR ERROR</p>	<p>The compressor has stopped suddenly.</p> <ul style="list-style-type: none"> •Unplug the power plug and call for service.



0E DRAIN PUMP ERROR	The drain pump motor has malfunctioned. <ul style="list-style-type: none"> •Unplug the power plug and call for service.
	The surrounding temperature for installation is below zero. <ul style="list-style-type: none"> •The recommended surrounding temperature for installation is 5 - 35 °C.

Operation



Symptoms	Possible Cause & Solution
Appliance will not turn on.	Power cord is not properly plugged in. <ul style="list-style-type: none"> •Make sure that the power plug is securely plugged into a grounded outlet matching the appliance's rating plate.
	House fuse is blown, circuit breaker has tripped, or power outage has occurred. <ul style="list-style-type: none"> •Reset circuit breaker or replace fuse. Do not increase fuse capacity. If the problem is a circuit overload, have it corrected by a qualified electrician.
Appliance does not heat.	House fuse is blown, circuit breaker has tripped, or power outage has occurred. <ul style="list-style-type: none"> •Reset circuit breaker or replace fuse. Do not increase fuse capacity. If the problem is a circuit overload, have it corrected by a qualified electrician.
Water leaks.	The water container hose or the optional drain hose is not connected correctly. <ul style="list-style-type: none"> •Connect the water container hose or the optional drain hose correctly.
	The door is closed while clothes or foreign substance is caught in the door. <ul style="list-style-type: none"> •Check if clothes or foreign substance is caught in the door before using the appliance. If water leaks continuously, contact the LG Electronics Customer Information Centre.



<p>Appliance runs and pauses by itself after the drying cycle finishes.</p>	<p>This is how the anti crease option works.</p> <ul style="list-style-type: none">•Make sure that the anti crease option has been set. The option is designed to prevent creases that are formed when the clothes are not unloaded promptly after the drying cycle. When the option is set, the appliance runs for 10 seconds and pauses for 5 minutes. The option is works for up to 2 hours.
--	--

Performance



Symptoms	Possible Cause & Solution
<p>Clothes take too long to dry.</p>	<p>Load is not properly sorted.</p> <ul style="list-style-type: none"> •Separate heavy items from lightweight items. Larger and heavier items take longer to dry. Light items in a load with heavy items can fool the sensor because the light items dry faster.
	<p>Large load of heavy fabrics.</p> <ul style="list-style-type: none"> •Heavy fabrics take longer to dry because they tend to retain more moisture. To help reduce and maintain more consistent drying times for large and heavy fabrics, separate these items into smaller loads of a consistent size.
	<p>Appliance controls are not set properly.</p> <ul style="list-style-type: none"> •Use the appropriate control settings for the type of load you are drying. Some loads may require an adjustment of the dry level setting for proper drying.
	<p>Lint filter needs to be cleaned.</p> <ul style="list-style-type: none"> •Remove the lint from the lint filter after every cycle. With the lint removed, hold the lint filter up to a light to see if it is dirty or clogged. With some loads that produce high amounts of lint, such as new bath towels, it may be necessary to pause the cycle and clean the filter during the cycle.
	<p>House fuse is blown, circuit breaker has tripped, or power outage has occurred.</p> <ul style="list-style-type: none"> •Reset circuit breaker or replace fuse. Do not increase fuse capacity. If the problem is a circuit overload, have it corrected by a qualified electrician.



Appliance is overloaded.

- Divide extra large loads into smaller loads for better drying performance and efficiency.

Appliance is underloaded.

- If you are drying a very small load, add a few extra items to ensure proper tumbling action. If the load is very small and you are using Sensor Dry programmes, the electronic control cannot properly sense the dryness of the load and may shut off too soon. Use Timed Drying programmes or add some extra wet clothes to the load.

<p>Drying time is not consistent.</p>	<p>Heat settings, load size, or dampness of clothing is not consistent.</p> <ul style="list-style-type: none"> •The drying time for a load will vary depending on the type of heat used (electric), the size of the load, the type of fabrics, the wetness of the clothes, and lint filter. Even an unbalanced load in the appliance can cause poor spinning, resulting in wetter clothes which will take longer to dry.
<p>Greasy or dirty spots are left on clothes.</p>	<p>Fabric softener is used incorrectly.</p> <ul style="list-style-type: none"> •When washing clothes that are to be dried in the appliance, use the correct amount of fabric softener as recommended by the manufacturer of the fabric softener.
	<p>Clean and dirty clothes are being dried together.</p> <ul style="list-style-type: none"> •Use the appliance to dry only clean items. Soil from dirty clothes can transfer to the clean clothes in the same or later loads.
	<p>Clothes were not properly cleaned or rinsed before being placed in the appliance.</p> <ul style="list-style-type: none"> •Stains on dried clothes could be stains that were not removed during the washing process. Make sure that clothes are being completely cleaned or rinsed according to the instructions for your washing machine and detergent. Some difficult soils may require pre-treating prior to washing.
<p>Clothes are wrinkled.</p>	<p>Clothes have dried too long (overdried).</p> <ul style="list-style-type: none"> •Over drying a load of clothes can lead to wrinkled clothes. Try a shorter drying time.
	<p>Clothes have been left in the appliance for too long after cycle ends.</p> <ul style="list-style-type: none"> •Use the Anti Crease option.



<p>Clothes are shrinking.</p>	<p>Garment care instructions are not being followed.</p> <ul style="list-style-type: none">•To avoid shrinking your clothes, always consult and follow fabric care instructions. Some fabrics will naturally shrink when washed. Other fabrics can be washed but will shrink when dried in the appliance. Use a low or no heat setting.
--------------------------------------	--



<p>Lint is left on clothes.</p>	<p>Lint filter has not been cleaned properly.</p> <ul style="list-style-type: none"> •Remove the lint from the lint filter after every cycle. With the lint removed, hold the lint filter up to a light to see if it is dirty or clogged. If it looks dirty, follow the cleaning instructions. With some loads that produce high amounts of lint, it may be necessary to clean the lint filter during the cycle.
	<p>Clothes have not been sorted properly.</p> <ul style="list-style-type: none"> •Some fabrics are lint producers (i.e., a fuzzy white cotton towel) and should be dried separately from clothes that are lint trappers (i.e., a pair of black linen pants).
	<p>Appliance is overloaded.</p> <ul style="list-style-type: none"> •Divide extra large loads into smaller loads for drying.
	<p>Tissue, paper, etc., has been left in pockets.</p> <ul style="list-style-type: none"> •Check pockets thoroughly before drying clothes.
<p>Excess static in clothes after drying.</p>	<p>Clothes have dried for too long (overdried).</p> <ul style="list-style-type: none"> •Overdrying a load of clothes can cause a buildup of static electricity. Adjust settings and use a shorter drying time, or use Sensor Dry programmes.
	<p>Drying synthetics, permanent press, or synthetic blends.</p> <ul style="list-style-type: none"> •These fabrics are naturally more prone to static buildup. Try using fabric softener, or use shorter Timed Drying time settings.
<p>Clothes have damp spots after a Sensor Dry programme.</p>	<p>Very large load or very small load. Single large item such as a blanket or comforter.</p> <ul style="list-style-type: none"> •If items are too tightly packed or too sparse the sensor may have trouble reading the dryness level of the load. Use a Timed Drying programme for very small loads. •Large, bulky items such as blankets or comforters can sometimes wrap themselves into a tight ball of fabric. The



	<p>outside layers will dry and register on the sensors, while the inner core remains damp. When drying a single bulky item, it may help to pause the cycle once or twice and rearrange the item to unwrap and expose any damp areas.</p> <ul style="list-style-type: none"> •To dry a few remaining damp items from a very large load or a few damp spots on a large item after a Sensor Dry programme has completed, empty the lint filter, then set a Timed Drying programme to finish drying the item(s).
--	---

Odours

Symptoms	Possible Cause & Solution
The appliance has an odour.	<p>Are you using the appliance for the first time?</p> <ul style="list-style-type: none"> •The smell is caused by rubber material that is attached to the appliance inside. This kind of smell is a rubber's own smell and disappears automatically after using the appliance several times.
	<p>Do you smell an odour during use?</p> <ul style="list-style-type: none"> •When washing the clothes, use the detergent in accordance with the manufacturers recommendations. If you use the detergent excessively not according to the recommendations, undissolved detergent may accumulate on the clothes and cause an odour. •You can smell odours from the clothes if the clothes were left in the appliance after drying or in the washing machine after washing. Unload the clothes promptly at the end of the drying or washing cycle. •Ensure you can smell same odour in the washing machine. If so, clean the tub of the washing machine referring to the washing machine user manual. •Always take care of both lint filters clean. If any residues were left in the lint filter after drying, it may cause odours. And also dry the lint filter completely after cleaning.

Wi-Fi



Symptoms	Possible Cause & Solution
<p>Your home appliance and smartphone is not connected to the Wi-Fi network.</p>	<p>The password for the Wi-Fi that you are trying to connect to is incorrect.</p> <ul style="list-style-type: none"> •Find the Wi-Fi network connected to your smartphone and remove it, then register your appliance on LG ThinQ.
	<p>Mobile data for your smartphone is turned on.</p> <ul style="list-style-type: none"> •Turn off the Mobile data of your smartphone and register the appliance using the Wi-Fi network.
	<p>The wireless network name (SSID) is set incorrectly.</p> <ul style="list-style-type: none"> •The wireless network name (SSID) should be a combination of English letters and numbers. (Do not use special characters.)
	<p>The router frequency is not 2.4 GHz.</p> <ul style="list-style-type: none"> •Only a 2.4 GHz router frequency is supported. Set the wireless router to 2.4 GHz and connect the appliance to the wireless router. To check the router frequency, check with your Internet service provider or the router manufacturer.
	<p>The distance between the appliance and the router is too far.</p> <ul style="list-style-type: none"> •If the distance between the appliance and the router is too far, the signal may be weak and the connection may not be configured correctly. Move the location of the router so that it is closer to the appliance.

Warning

This content is compiled from multiple sources and is provided for reference purposes only. It may not be complete or fully applicable to all situations. If you are unable to resolve your issue, please contact the product manufacturer or an authorized service provider for official support.



