

FEATURES & FUNCTIONS

TOP PANEL

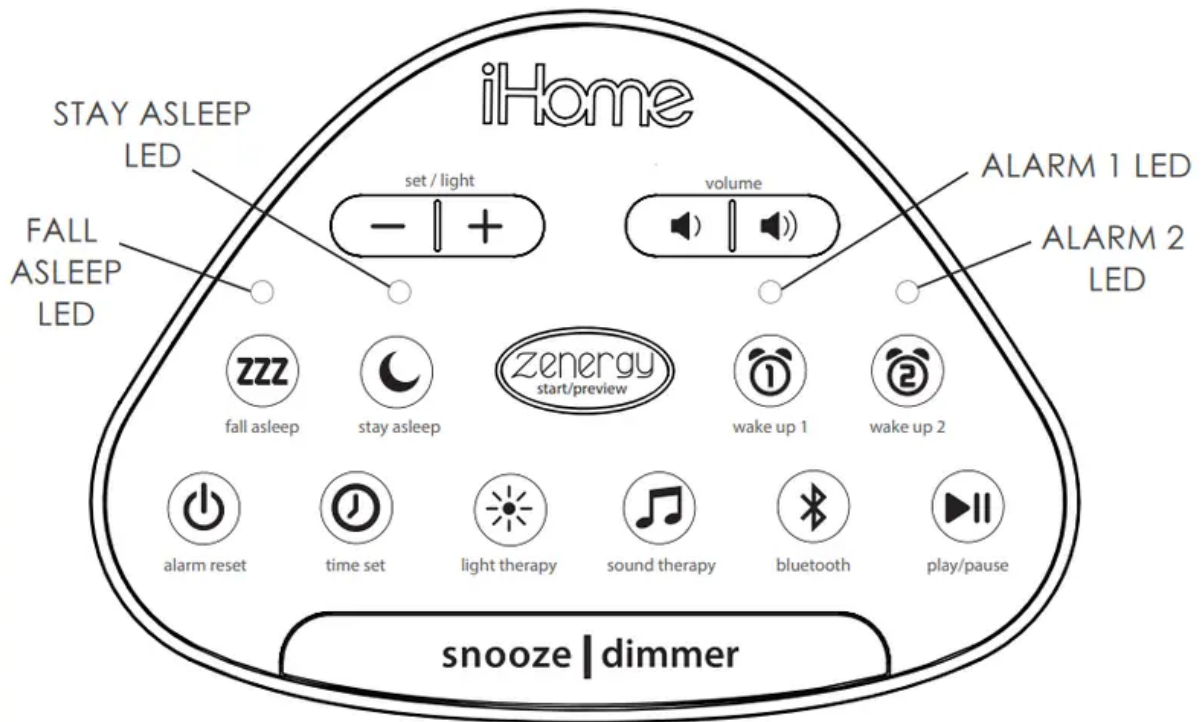

Press the Snooze/Dimmer button to adjust the brightness of the clock display. Cycle through settings: Max, Mid, Low, Min, Button (display off/buttons backlit), and Auto (display/buttons backlit for 15 seconds).

BACK PANEL

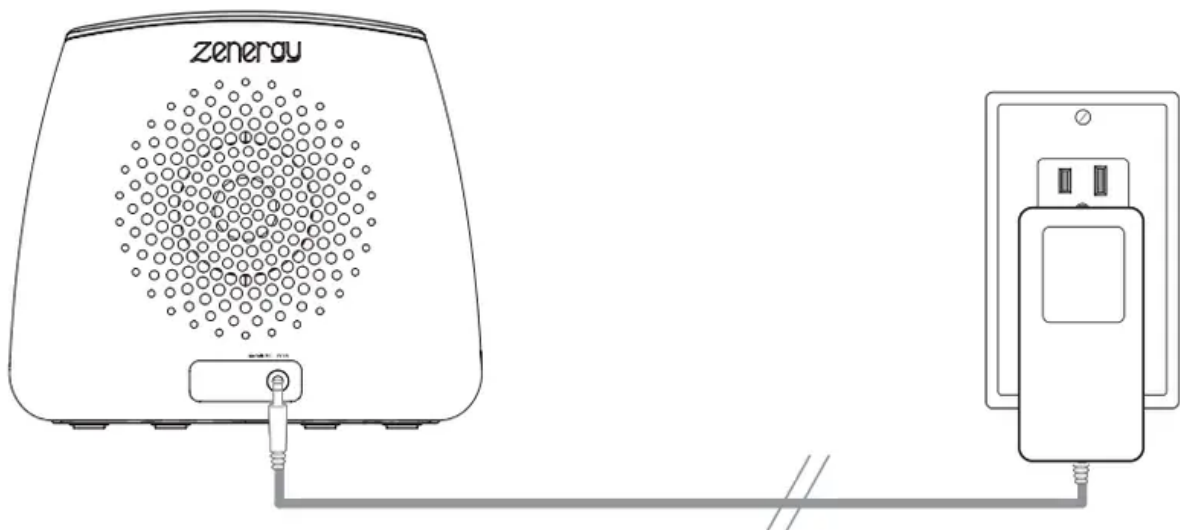

Plug the included AC adapter into the DC jack and connect the plug to a working outlet not controlled by a light switch.

CLOCK DISPLAY

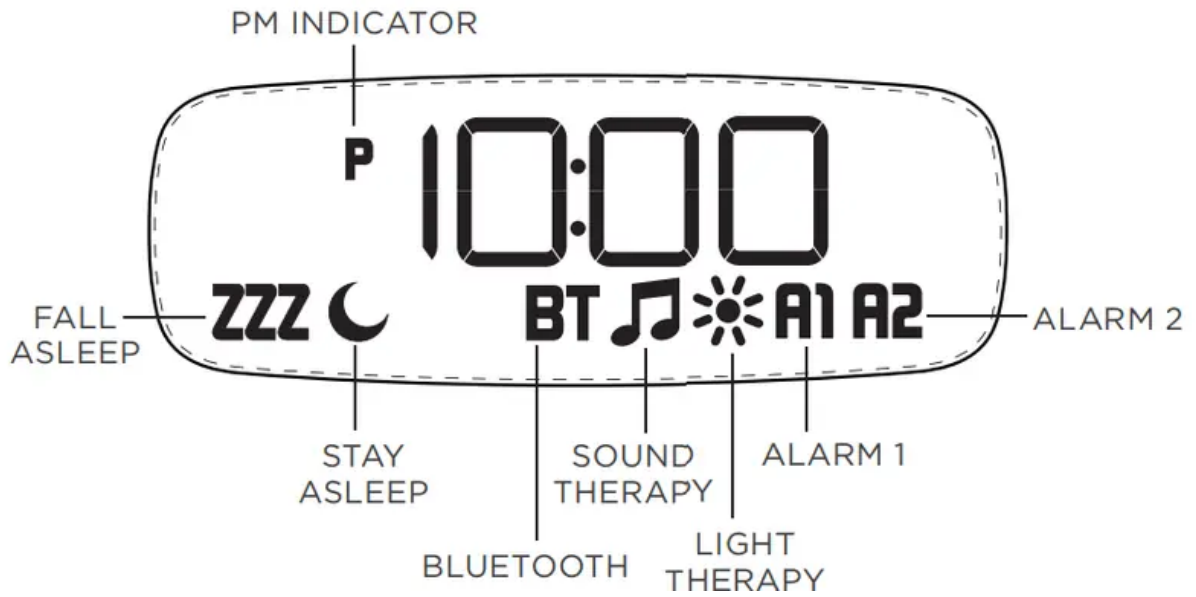

BOTTOM PANEL

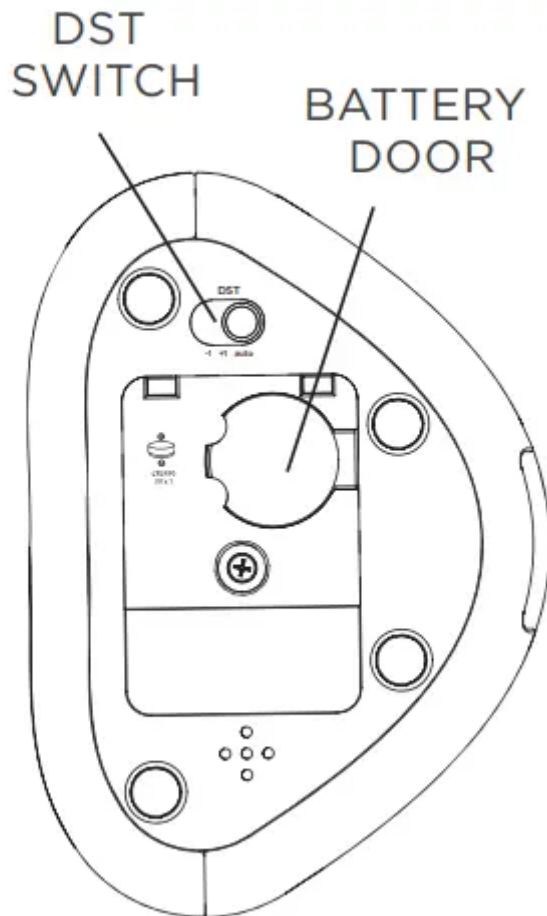

Backup Battery:

The built-in backup battery will maintain time and alarm settings in the event of a temporary power outage. To replace, unscrew the door on the bottom of the unit and install a new CR2450 battery into the compartment.

DST Switch:

The clock will automatically adjust during Daylight Saving Time (DST) in March and November. To adjust manually, slide the DST Switch to +1 to add an hour or -1 to subtract an hour.



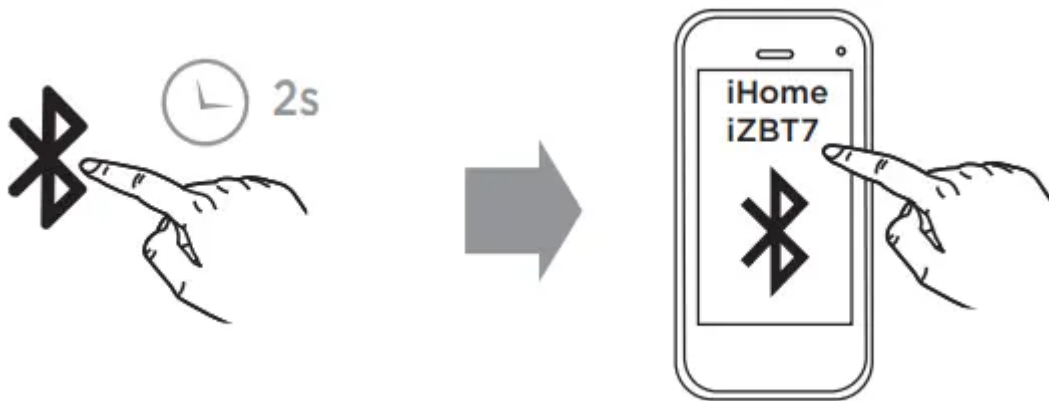

CONNECTING TO BLUETOOTH



(press the bluetooth button to switch from Sound Therapy Mode to Bluetooth Mode.)



When playing audio, press and hold the + and - buttons on the iZ8t7 to navigate tracks.

SETTING THE TIME

1. Press and hold the Time Set Button  until the display flashes.
2. Press the + or - buttons to adjust the clock to the current time. (Hold for rapid adjustment). Make sure you set the correct AM/PM time. The PM indicator will appear on the top left corner of the display. (There is no AM indicator.)
3. To toggle the clock display between 12 and 24 hour time, press Alarm 1 or Alarm 2 ( or ) while the display is flashing.
4. Press and release the Time Set Button  to confirm the time. The year will flash on the display. Press the + or - buttons to adjust the year.
5. Press and release the Time Set Button  to confirm the year. The date/month will flash on the display. Press the + or - buttons to adjust the date/month.

6. Press and release the Time Set Button  to confirm all settings.

SETTING ALARMS ZENERGY BUTTON

This unit has dual alarms that can be set for different times and different wake-to sources. Each is set in the same way. Instructions are given as 'Alarm Button' - use Alarm 1  or Alarm 2  Buttons to set respective alarms.

1. Press and hold the Alarm Button until the display flashes.
2. Press the + or - buttons to adjust the alarm time. Make sure you set the correct AM/PM time. The PM indicator will appear on the top left corner of the display. (There is no AM indicator.)
3. Press the Alarm Button to confirm the alarm time. Next, set your alarm light therapy preference by pressing the + or - buttons. (If you choose Dawn or Sunrise, the pre-alarm will activate a light mode before your alarm sounds that will gradually increase in brightness for a duration of 10 minutes.)
4. Press the Alarm Button to confirm the alarm light mode. Next, press the + or - buttons to cycle through wake-to sources for your alarm: Bluetooth, buzzer, none or sound therapy modes. Note: Sound therapy will not activate when an alarm is set to Bluetooth or buzzer modes.
5. Press the Alarm Button to confirm the wake-to source. If you chose to wake-to sound therapy, press the + or - buttons to cycle through sound modes.
6. Press the Alarm Button to confirm wake-to volume. Press the + or - buttons to adjust wake-to sound volume level.
7. Now press the Alarm Button to set the alarm schedule. Press the + or - buttons to cycle through alarm schedules: 7 (every day), 5 (weekdays only), or 2 (weekends only).
8. Press the Alarm Button to confirm all alarm settings. The alarm icon will appear on the display, and the corresponding alarm LED will glow on the top of the unit.

SNOOZING/STOPPING ALARMS

- To snooze a sounding alarm: Press the Snooze/Dimmer Button to snooze for 9 minutes.
- To stop a sounding alarm: Press the corresponding Alarm Button (Alarm 1 or Alarm 2) or the Power/Alarm Reset Button to disable the alarm and reset it for the next day.







ZENERGY BUTTON

Use the Zenergy Button to activate a calming sound and light therapy experience. You can also customize your own sound and light therapy preferences by using our Fall Asleep and Stay Asleep options to enable a relaxing sequence to gently help you fall asleep and gently transition to sound masking mode for the remainder of the night, blocking out loud noises and helping you achieve your deepest sleep.

Once you have confirmed your custom sleep settings for Fall Asleep or Stay Asleep, press the Zenergy Button to activate one or both personalized sleep therapy programs. Press and hold the Zenergy Button at any time to preview current settings.







FALL ASLEEP (LED WILL GLOW WHEN ACTIVATED)

The Fall Asleep Button  lets you choose from a selection of light and sound therapy options designed to trigger your brain's ability to relax and fall asleep quickly.

1. Press and hold the Fall Asleep Button. Press the Sound Therapy Button  to select a sound, or press the Bluetooth button to fall asleep to audio from your Bluetooth device (your device must be connected to the iZBT7). Then adjust the volume using  or .
2. Press  again to confirm sound and volume settings. Now press the Light Therapy Button  to cycle through light modes, and adjust the brightness using the + or - buttons.
3. Press  again to confirm light and brightness settings. Now choose a time duration (10, 15, 30, 60, 90, or 120 minutes) using the + or - buttons. Press  again to confirm all settings.
4. Press the Zenergy Button to activate your custom Fall Asleep settings

STAY ASLEEP (LED WILL GLOW WHEN ACTIVATED)

The Stay Asleep Button  lets you further personalize your own sleep therapy experience with a gentle transition to sound and light options after the Fall Asleep timer expires. The Stay Asleep program will play for the remainder of the night to help you stay asleep.

1. Press and hold the Stay Asleep Button. Press the Sound Therapy Button  to cycle through sounds, then adjust the volume using  or  .
2. Press  again to confirm sound and volume settings. Now press the Light Therapy Button  to cycle through light modes, and adjust the brightness using the + or - buttons.
3. Press  again to confirm all settings.
4. Press the Zenergy Button to activate your custom Stay Asleep settings. The Stay Asleep function will be disabled once your alarm is activated. To manually disable, press the Stay Asleep button. The corresponding LED will shut off.

SOUND THERAPY

Sound Therapy uses specially recorded and engineered sounds to allow your mind to calm and prepare for sleep. Press the Sound Therapy Button to access a variety of soothing sounds. Continue to press to cycle to each mode:

4-7-8: A guided breathing meditation to soothe body and mind (see next page for details)

Breath: A breathing meditation sound effect for focus and relaxation (see next page for details)

Zen: A tonal melody in frequencies that mimic the Delta brainwaves of a mind in meditation or healing sleep

Dream: A tonal melody in frequencies that mimic the Theta brainwaves of a mind dreaming in REM sleep

Peace: White noise and Delta tone melodies layered together help to quiet a noisy environment and an over-active mind

Trance: A peaceful tonal melody designed to quiet the mind.

Nature: Springtime woodland sounds

Ocean: Waves crashing on a beach

River: Flowing natural river after a storm

Storm: Subtle thunder and strong rainfall

Chimes: Outdoor wind chimes and soothing breeze

Air: Brown noise is a low-toned repeating frequency, like a fan, which helps to negate distracting environmental noises

Drive: An authentically recorded car ride interior to negate distracting environmental noises

Focus: Pink noise is a medium-toned repeating frequency, like a soothing waterfall, which helps to negate distracting environmental noises

Quiet: The standard white noise repeating frequency, like radio static, which helps to actively negate distracting environmental noises

Heart: Mimics the rhythm of a heartbeat to promote steady breathing patterns

LIGHT THERAPY

Press the Light Therapy Button repeatedly to cycle through light modes:

- 4-7-8
- Breath
- Calm
- Aurora
- Glow
- One Color
- Pulse
- Energy
- Lamp
- OFF

Press the + and - buttons to adjust the brightness.

MEDITATION & BREATHING

Research has shown that active breathing can calm the nervous system thereby reducing your heart rate and activating the parasympathic (calming) nervous system to improve memory,

positively impact emotional behaviors to help cope with stress, anxiety and make it easier to fall asleep.

Select the 4-7-8 Breathing Meditation Sound and Light Therapy options to experience a soothing voiced guide that fades and synchronizes with pulsing lighting effects to control your breath, lower your heart rate and soothe the body and mind.

4 sec Breathe in through your nose, filling the belly.

7 sec Hold breath.

8 sec Slowly exhale through your mouth. Repeat.

Select the Breath Sound and Light Therapy options to experience a calming breathing sound effect that can help coax your mind into a deep meditative state. This is a great alternative and easier exercise than the 4-7-8 method.

5 sec Breathe in slowly through your nose.

5 sec Exhale slowly through your mouth. Repeat.



SUNRISE WAKE UP

Circadian rhythms, our internal clocks, are linked to changing wavelengths of light throughout the day. Light Therapy simulates these wavelengths, triggering subtle biological responses that can improve your sleep experience, energy and mood.

Select the Sun or Dawn Wake to Light Therapy options to wake up naturally with a simulated sunrise or early dawn light experience that gradually increases to a bright glow 10 minutes before your alarm is set.

You can also customize alarms that exclusively Wake to Light to alert your toddler when it is ok to get out of bed in the morning.

IMPORTANT SAFETY INSTRUCTIONS

Please heed all warnings, read and follow all instructions and keep these instructions handy for future reference. Heat – The unit should be situated away from heat sources such as radiators, heat registers, stoves or other appliances (including amplifiers) that produce heat.

Only use attachments/accessories specified by the manufacturer. This product is suitable for use in tropical and/or moderate climates. The unit should be serviced by qualified service personnel when the enclosure damaged or does not operate normally. No naked flame sources, such as lighted candles, should be placed on the apparatus

- Do not use this apparatus near water

- Clean only with dry cloth
- Do not block any ventilation opening
- Unplug this apparatus during lightning storm or when unused for long periods of time

Warning: To reduce the risk of fire or electric shock, do not expose this appliance to rain or moisture

Damage Requiring Service

- This product should be serviced by qualified service personnel when:
- Plug has been damaged.
- objects have fallen into or liquid has been spilled into the enclosure.
- the unit has been exposed to rain.
- the unit has been dropped or the enclosure damaged.
- the unit exhibits a marked change in performance or does not operate normally

CAUTION – Danger of explosion if battery is incorrectly replaced. Replace only with the same or equivalent type The mains plug of power adaptor is used as the disconnect device, it shall remain readily operable

WARNING Do not ingest the battery, Chemical Burn Hazard. This product contains a coin/button cell battery. If the coin/button cell battery is swallowed, it can cause severe internal burns in just 2 hours and can lead to death. Keep new and used batteries away from children. If the battery compartment does not close securely, stop using the product and keep it away from children. If you think batteries might have been swallowed or placed inside any part of the body, seek immediate medical attention.

Warning

This content is compiled from multiple sources and is provided for reference purposes only. It may not be complete or fully applicable to all situations. If you are unable to resolve your issue, please contact the product manufacturer or an authorized service provider for official support.