

Before first use

1. Remove all packing material.
2. Remove any stickers or labels from the appliance.
3. Thoroughly clean the appliance before first use, as indicated in the cleaning table.

Preparing for use

Placing the removable mesh bottom and fat reducer

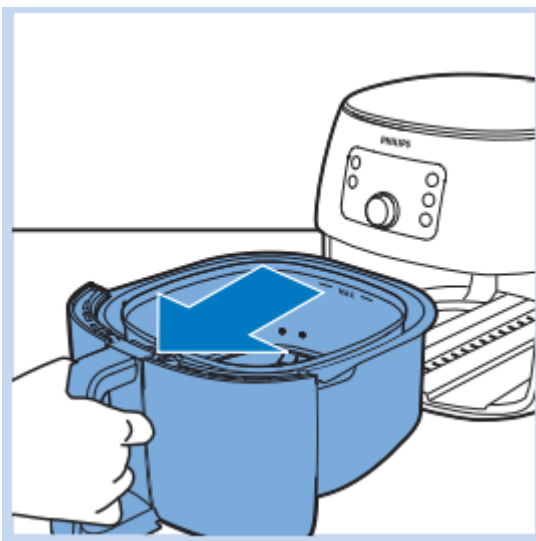

1. Open the drawer by pulling the handle.

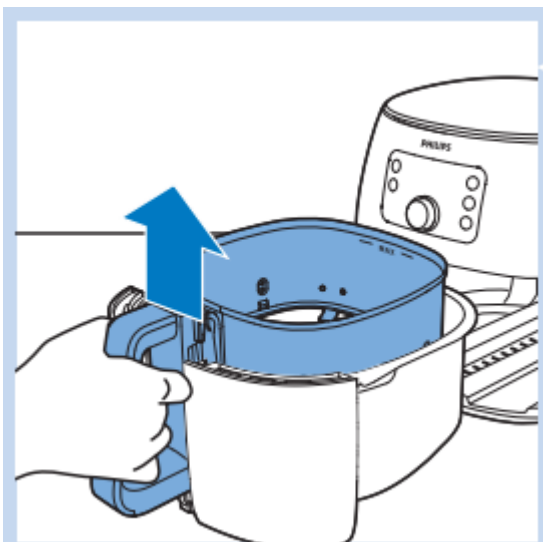

2. Remove the basket by lifting the handle.

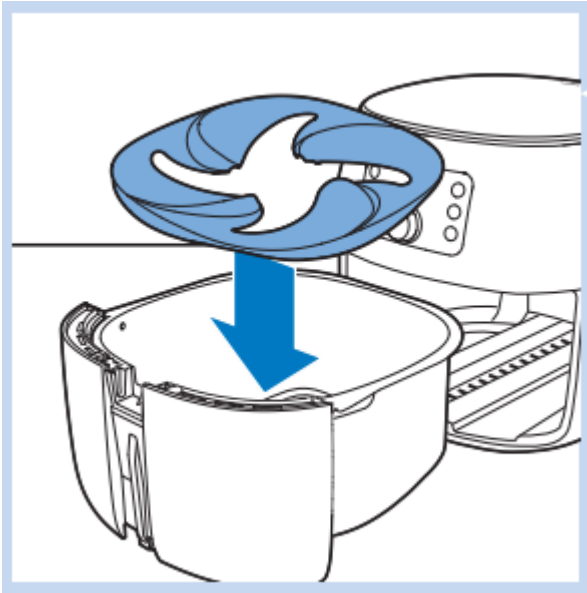

3. Place the fat reducer into the pan.

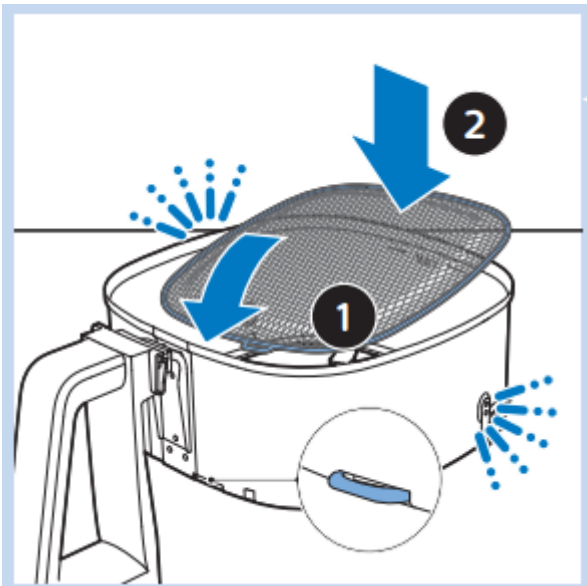

4. Insert the removable mesh bottom into the slot on the right bottom side of the basket. Push the mesh bottom down until it locks into position (“click” on both sides).

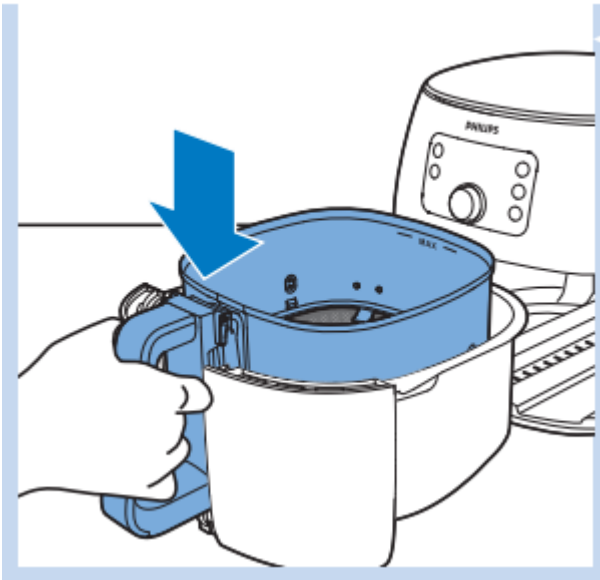

5. Put the basket in the pan.

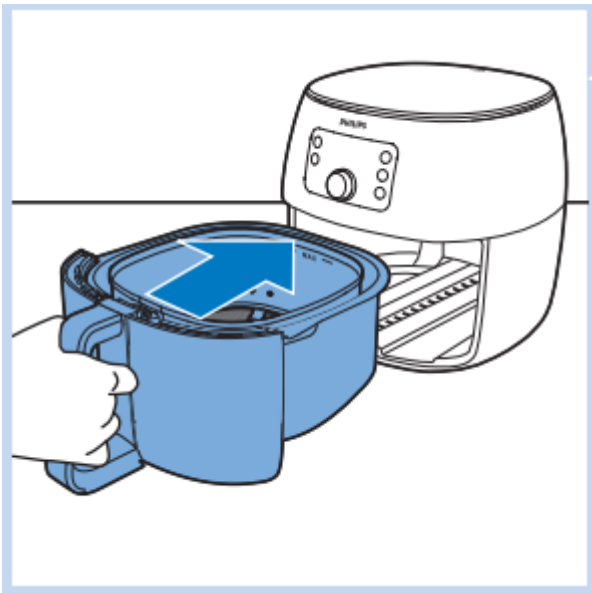

6. Slide the drawer back into the Airfryer by the

handle.

Note

- Never use the pan without the fat reducer or the basket in it.

Using the appliance

Airfrying



Caution

- This is an Airfryer that works on hot air. Do not fill the pan with oil, frying fat or any other liquid.
- Do not touch hot surfaces. Use handles or knobs. Handle the hot pan and fat reducer with oven-safe gloves.
- This appliance is for household use only.
- This appliance may produce some smoke when you use it for the first time. This is normal.
- Preheating of the appliance is not necessary.

1. Place the appliance on a stable, horizontal, level and heat-resistant surface. Make sure the drawer can be opened completely.

Note

- Do not put anything on top or on the sides of the appliance. This could disrupt the airflow and affect the frying result.

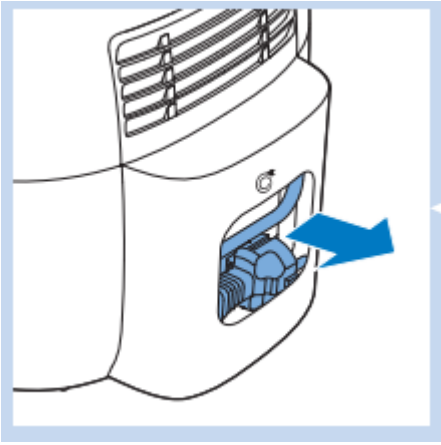

2. Pull the power cord out of the cord storage compartment at the back of the appliance.

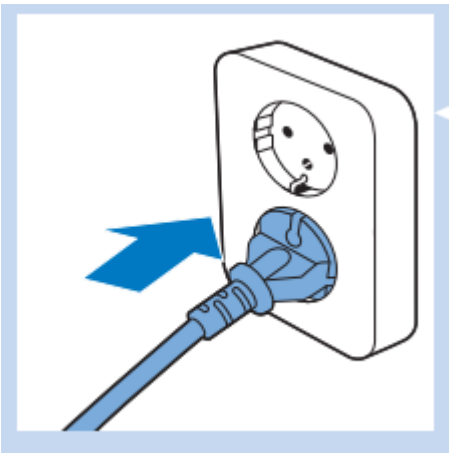

3. Put the plug in the wall outlet.

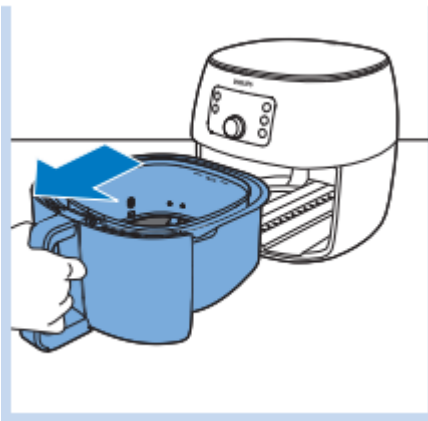

4. Open the drawer by pulling the handle.



5. Put the ingredients in the basket.

Note

- The Airfryer can prepare a large range of ingredients. Consult the 'Food table' for the right quantities and approximate cooking times.
- Do not exceed the amount indicated in the 'Food table' section or overfill the basket beyond the 'MAX' indication as this could affect the quality of the end result.
- If you want to prepare different ingredients at the same time, make sure you check the suggested cooking time required for the different ingredients before you start to cook them simultaneously.



6. Slide the drawer back into the Airfryer by the handle.

Caution

- Never use the pan without the fat reducer or basket in it. If you heat up the appliance without basket, use oven gloves to open the drawer. The edges and inside of the drawer become very hot.
- Do not touch the pan, fat reducer or basket during and for some time after use, as they get very hot.

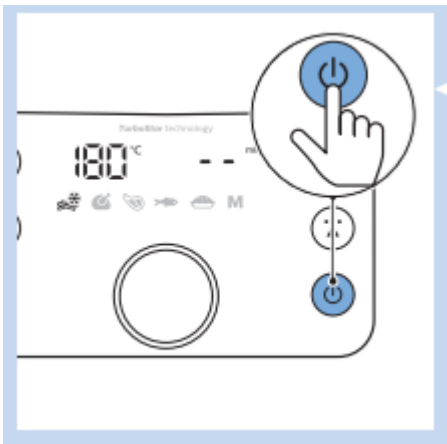

7. Press the Power On/Off () button to switch on the appliance.

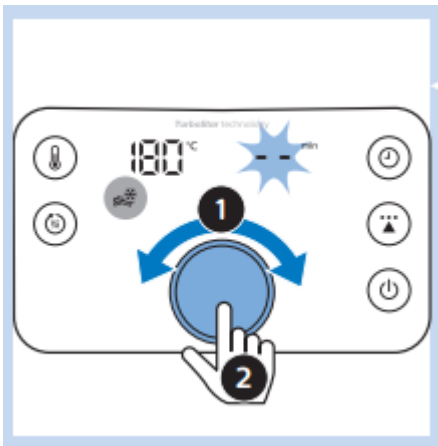

8. To change the preset, turn the QuickControl dial to the desired setting.

» To confirm the selected preset, push the QuickControl dial. The cooking time indication blinks on the screen.

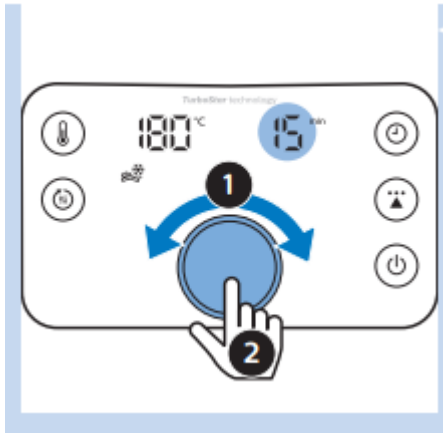

9. To change the cooking time, turn the QuickControl dial to the desired setting.

» To confirm the selected cooking time, push the QuickControl dial.

Note

- Refer to the food table with basic cooking settings for different types of food.

10. The appliance starts cooking after the cooking time has been confirmed.

Tip

- To pause the cooking process, push the QuickControl dial. To resume the cooking process, push the QuickControl dial again.

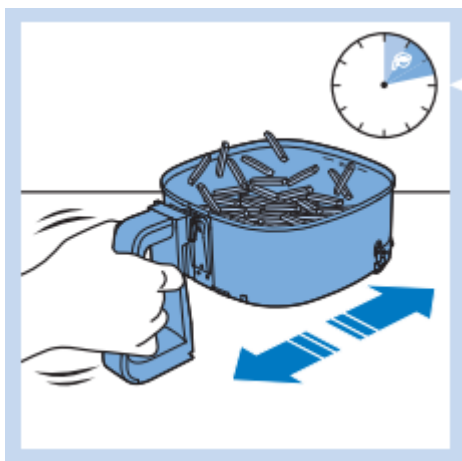

Note

- If you do not set the required cooking time within 30 minutes, the appliance automatically shuts off for safety reasons.
- If “- -” is selected as the time indication, the appliance goes into preheating mode.
- Some ingredients require shaking or turning halfway through the cooking time (see ‘Food table’). To shake the ingredients, press the QuickControl dial to pause cooking, open the drawer and lift the basket out of the pan and shake it over the sink. Then slide the pan with the basket back into the appliance, and press the QuickControl dial to resume cooking.



- If you set the timer to half the cooking time, when you hear the timer bell it is time to shake or turn the ingredients. Be sure to reset the timer to the remaining cooking time.



11. When you hear the timer bell, the set preparation time has elapsed.



12. Open the drawer by pulling the handle and check if the ingredients are ready.

Note

- If the ingredients are not ready yet, simply slide the drawer back into the Airfryer by the handle and add a few extra minutes to the set time.

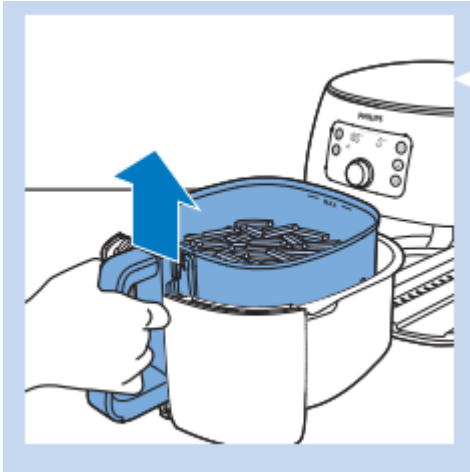

13. To remove small ingredients (e.g. fries), lift the basket out of the pan by the handle.

Caution

- After the cooking process, the pan, the fat reducer, the basket, interior housing and the ingredients are hot. Depending on the type of ingredients in the Airfryer, steam may escape from the pan.

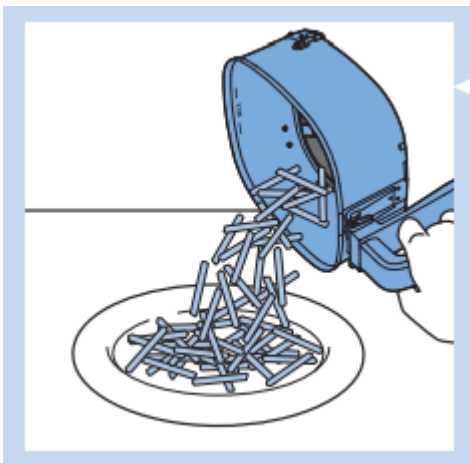

14. Empty the basket contents into a bowl or onto a plate. Always remove the basket from the pan to empty contents as hot oil may be in bottom of the pan.

Note

- To remove large or fragile ingredients, use a pair of tongs to lift out ingredients.
- Excess oil or rendered fat from the ingredients is collected on the bottom of the pan below the fat reducer.
- Depending on the type of ingredients cooking, you may want to carefully pour off any excess oil or rendered fat from the pan after each batch or before shaking or replacing the basket in the pan. Place the basket on a heat-resistant surface. Wearing oven-safe gloves, lift the pan off tracks and place on heat-resistant surface. Carefully remove the fat separator

from the pan using rubber tipped tongs. Pour off excess oil or rendered fat. Return the fat separator to the pan, the pan to the drawer and the basket to the pan.

When a batch of ingredients is ready, the Airfryer is instantly ready for preparing another batch.

Note

- Repeat steps 1 to 14 if you want to prepare another batch.

Changing to another preset during cooking

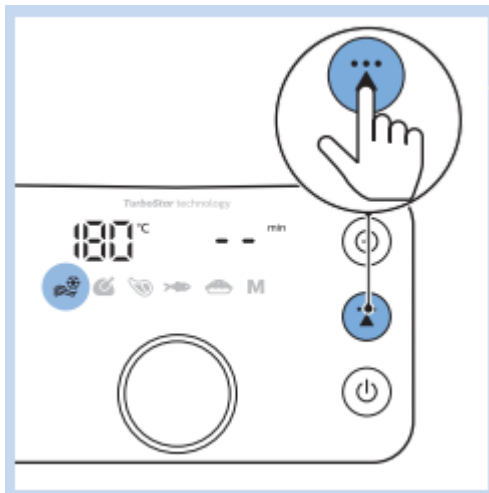

1. Press the preset () button.

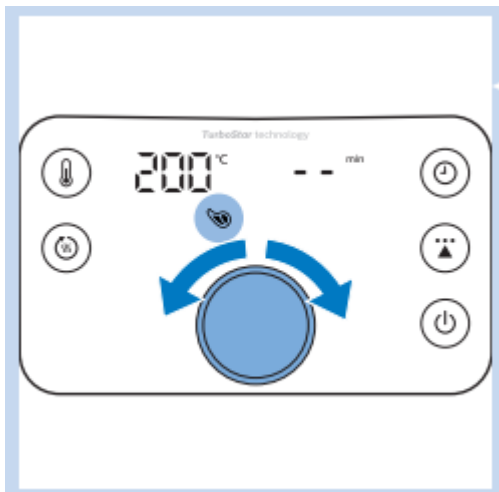

2. Turn the QuickControl dial to select another preset.

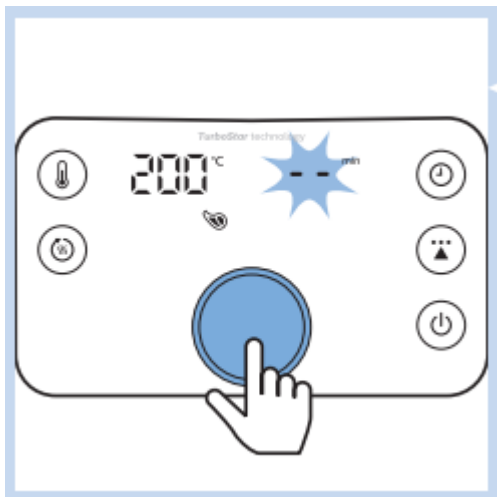

3. To confirm the selected preset, push the QuickContr

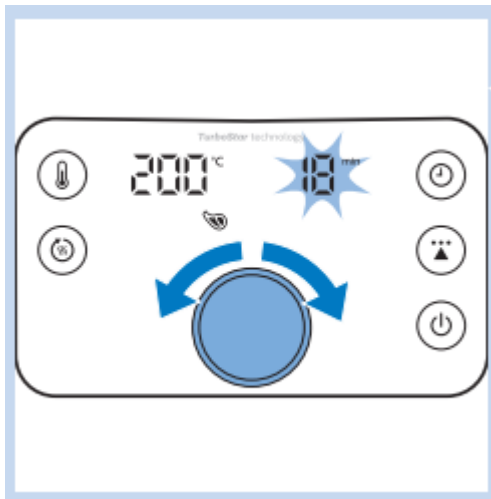

4. To change the cooking time, turn the QuickControl dial.

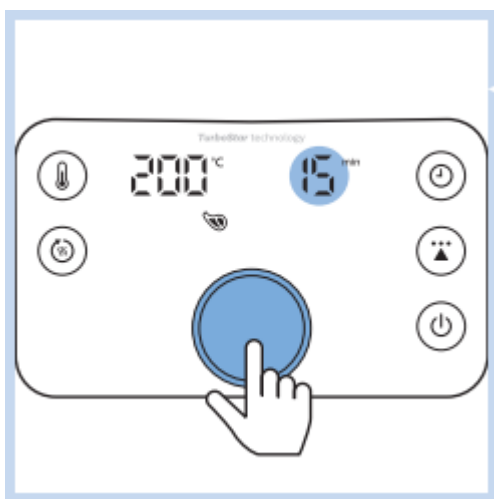

» To confirm the selected cooking time, push the QuickControl dial.

Using the manual mode

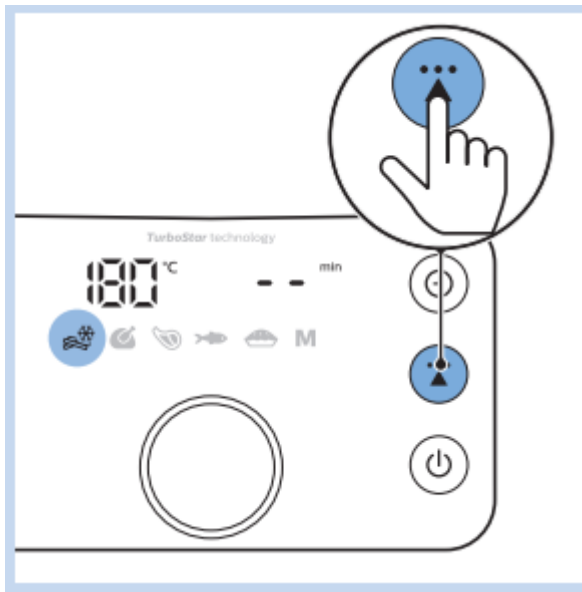

1. Press the preset () button.

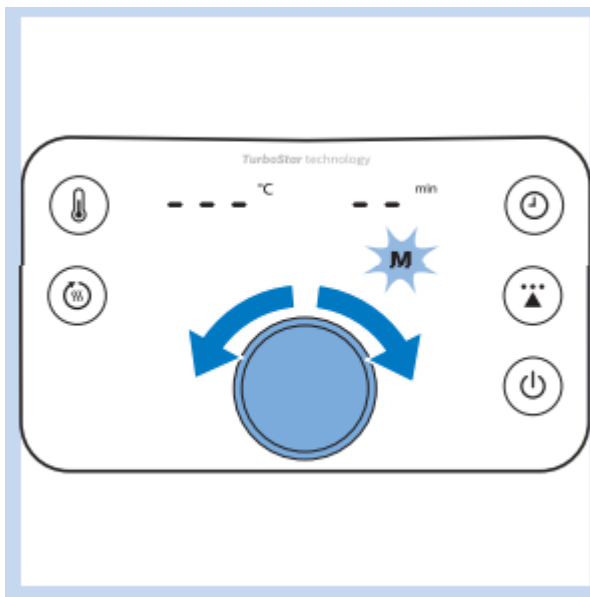

2. Turn the QuickControl dial to select the manual mode (**M**).

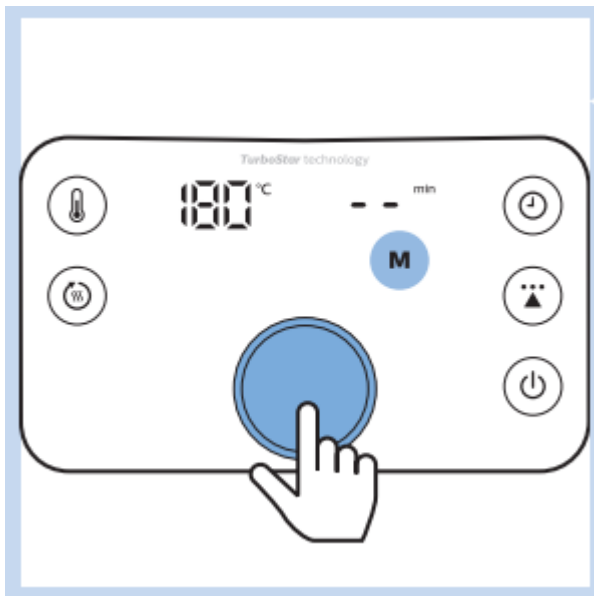

3. Push the QuickControl dial to enter the manual mode.

» The default temperature is 180°C.

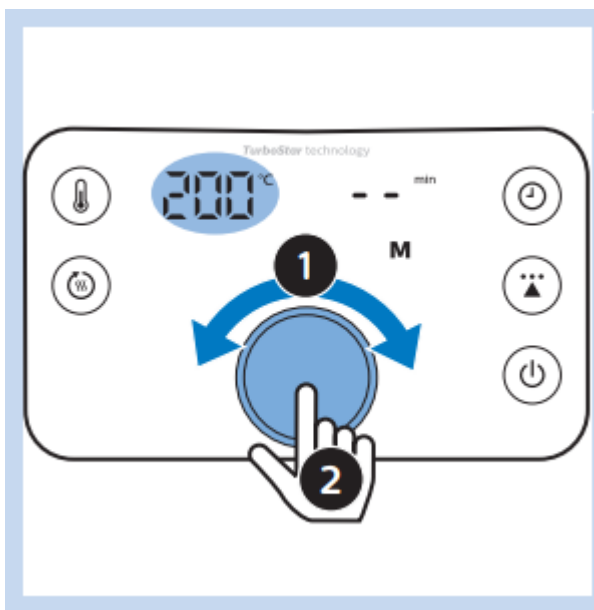

4. To change the temperature, turn the QuickControl dial.

» To confirm the temperature, push the QuickControl dial.

5. After the temperature is confirmed, the time indication "--" starts blinking.

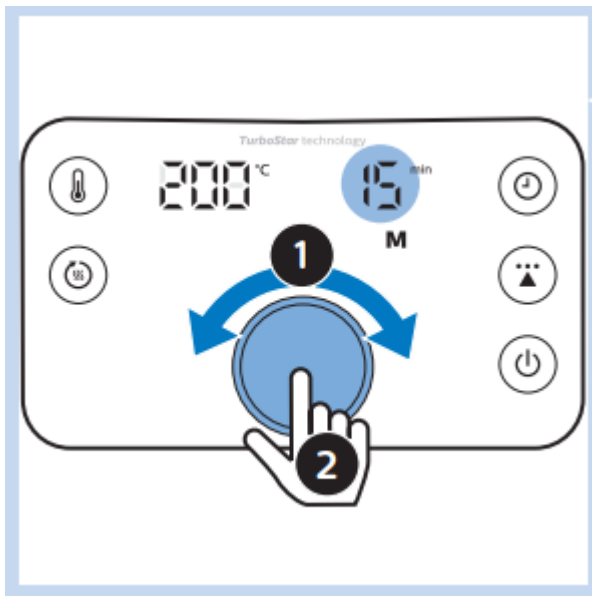

6. To change the cooking time, turn the QuickControl dial.

» To confirm the cooking time, push the QuickControl dial.

Changing the cooking temperature or time at any time

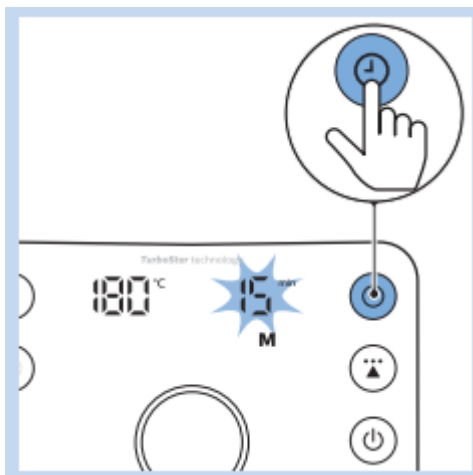
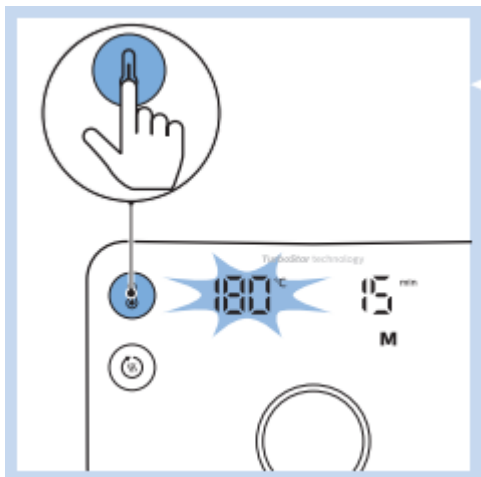

1. Press the temperature (🌡️) or timer (⏻) button

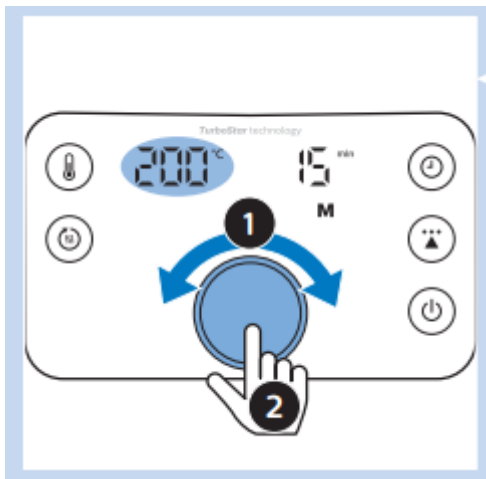

2. To change the cooking temperature or time, turn the QuickControl dial.

» To confirm the cooking temperature or time, push the QuickControl dial or the temperature/timer button again.

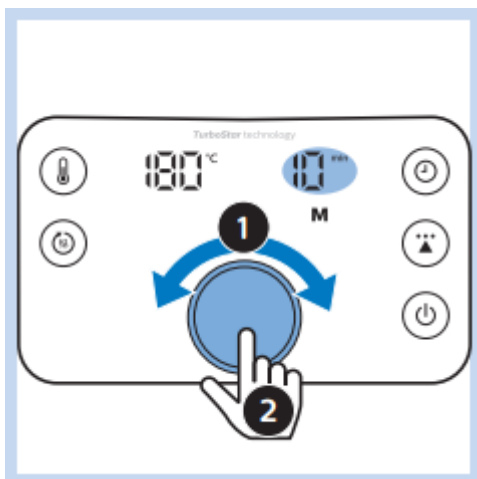

Note

- If you do not press the QuickControl dial or the temperature/ timer button to confirm the changes, they will be automatically confirmed after 10 seconds.

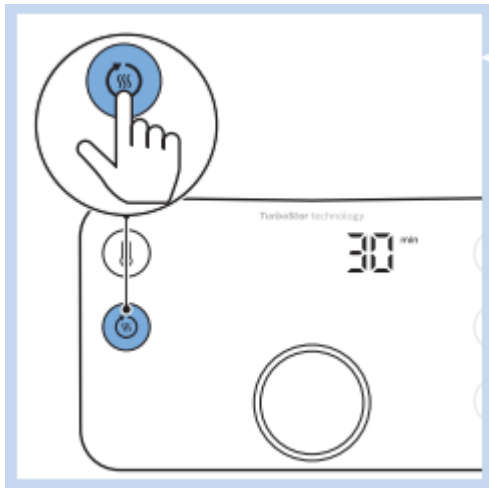

1. Press the keep warm (SSS) button (you can activate the keep warm mode at any time).

» The keep warm button lights up with pulsing effect.

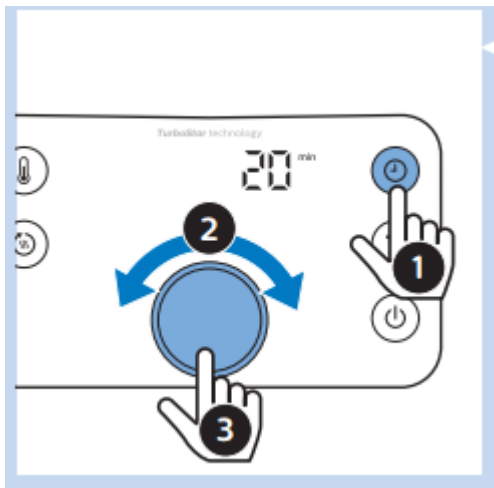

» The keep warm timer is set to 30 minutes. To change the keep warm time (1-30 min), press the timer button (🕒), turn the QuickControl dial and then push it to confirm. You cannot adjust the keep warm temperature.

2. To pause the keep warm mode, push the QuickControl dial. To resume the keep warm mode, push the QuickControl dial again.

3. To exit the keep warm mode, press one of the following buttons: preset button, temperature button, or On/Off button.

Tip

- If food like French fries loses too much crispness during the keep warm mode, either shorten the keep warm time by switching off the appliance earlier or crisp them up for 2-3 minutes at the temperature of 180°C.

Note

- If you activate the keep warm mode during cooking (the keep warm button lights up with pulsing effect), the appliance will keep your food warm for 30 minutes after the cooking time has elapsed.
- During the keep warm mode, the fan and heater inside of the appliance turn on from time to time.
- The keep warm mode is designed to keep your dish warm immediately after it is cooked in the Airfryer. It is not meant for reheating.

Making home-made fries

To make great home-made fries in the Airfryer:

- Choose a potato variety suitable for making fries, e.g. fresh, (slightly) floury potatoes.
- It is best to air fry the fries in portions of up to 1000 grams for an even result. Larger fries tend to be less crispy than smaller fries.
- Shake the basket 2-3 times during the airfrying process.
 1. Peel the potatoes and cut into sticks (8x8mm / 0.3 in thick).
 2. Soak the potato sticks in a bowl of water for at least 30 minutes.
 3. Empty the bowl and dry the potato sticks with a dish towel or paper towel.
 4. Pour a half tablespoon of cooking oil in the bowl, put the sticks in the bowl and mix until the sticks are coated with oil.
 5. Remove the sticks from the bowl with your fingers or a slotted kitchen utensil so excess oil remains in the bowl.

Note

- Do not tilt the bowl to pour all the sticks in the basket at once to prevent excess oil from going into the pan.
- 6. Put the sticks in the basket.
- 7. Fry the potato sticks and shake the basket halfway through the airfrying process. Shake 2-3 times if you prepare more than 500g of fries.

Note

- Consult the chapter “Food table” for the right quantities and cooking times.

Cleaning

Warning

- Let the basket, pan, fat reducer and the inside of the appliance cool down completely before you start cleaning.

•Remove the fat reducer from the pan using rubber tipped tongs. Do not remove using your fingers as hot fat or oil collects under the fat reducer.

•The pan, basket, fat reducer and inside of the appliance have a non-stick coating. Do not use metal kitchen utensils or abrasive cleaning materials as this may damage the non-stick coating.

Clean the appliance after every use. Remove oil and fat from the bottom of the pan after every use.

1. Press the power On/Off () button to switch off the appliance, remove the plug from the wall outlet and let the appliance cool down.

Tip

- Remove the pan and basket to let the Airfryer cool down more quickly.
2. Remove the fat separator from the pan using rubber tipped tongs. Dispose of rendered fat or oil from the bottom of the pan.
 3. Clean the pan, basket and fat reducer in a dishwasher. You can also clean them with hot water, dishwashing liquid and a non-abrasive sponge (see 'cleaning table').

Tip

- If food residues stuck to the pan, fat reducer or basket, you can soak them in hot water and dishwashing liquid for 10-15 minutes. Soaking loosens the food residues and makes it easier to remove. Make sure you use a dishwashing liquid that can dissolve oil and grease. If there are grease stains on the pan, fat reducer or basket and you have not been able to remove them with hot water and dishwashing liquid, use a liquid degreaser.
- If necessary, food residues stuck to the heating element can be removed with a soft to medium bristle brush. Do not use a steel wire brush or a hard bristle brush, as this might damage the coating on the heating element.

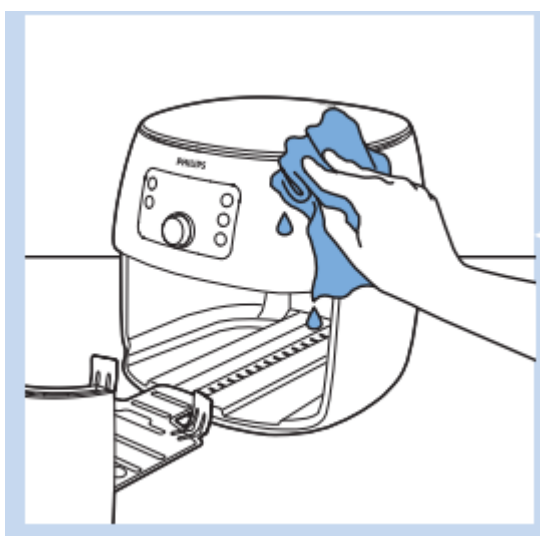

4. Wipe the outside of the appliance with a moist cloth.

Note

- Make sure no moisture remains on the control panel. Dry the control panel with a cloth after you have cleaned it.

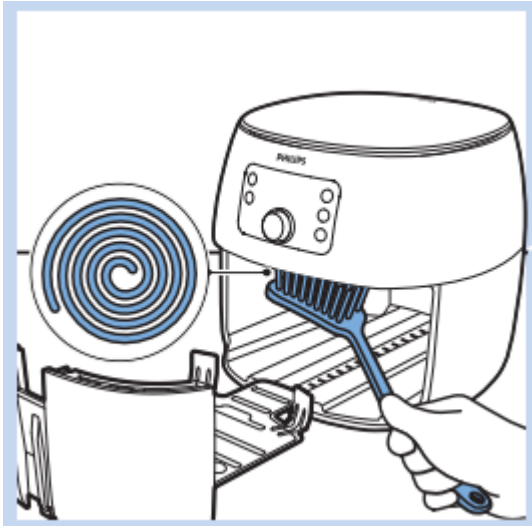

5. Clean the heating element with a cleaning brush to remove any food residues.

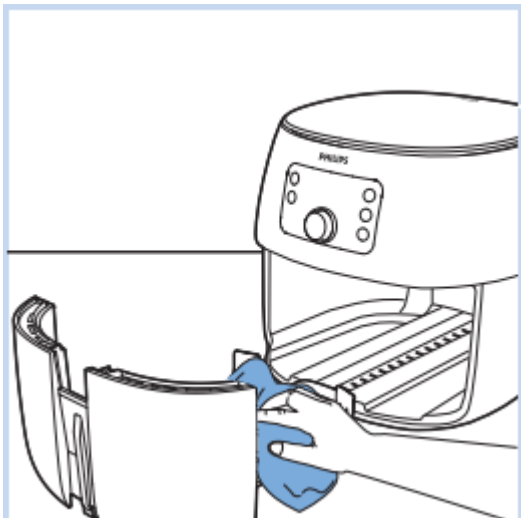

6. Clean the inside of the appliance with hot water and a non-abrasive sponge.

Troubleshooting

Problem	Possible cause	Solution
The outside of the appliance becomes hot during use.	The heat inside radiates to the outside walls.	This is normal. All handles and knobs that you need to touch during use stay cool enough to touch.



		<p>The pan, basket, fat reducer, and the inside of the appliance always become hot when the appliance is switched on to ensure the food is properly cooked. These parts are always too hot to touch.</p>
		<p>If you leave the appliance switched on for a longer time, some areas get too hot to touch. These areas are marked on the appliance</p> <p>with the following icon: </p> <p>As long as you are aware of the hot areas and avoid touching them, the appliance is completely safe to use.</p>
<p>My home-made fries do not turn out as I expected.</p>	<p>You did not use the right potato type.</p>	<p>To get the best results, use fresh (slightly) floury potatoes. If you need to store the potatoes, do not store them in a cold environment like in a fridge.</p> <p>Choose potatoes whose package states that they are suitable for frying.</p>
	<p>The amount of ingredients in the basket is too big.</p>	<p>Follow the instructions in this user manual to prepare home-made fries (see 'Food table' or download the free Airfryer App).</p>
	<p>Certain types of ingredients need to be shaken halfway through the cooking time.</p>	<p>Follow the instructions in this user manual to prepare home-made fries (see 'Food table' or download the free Airfryer App).</p>
<p>The Airfryer does not switch on.</p>	<p>The appliance is not plugged in.</p>	<p>When you switch on the appliance, you hear the sound of the working fan. If you do not hear this sound, check if the plug is inserted in the wall outlet properly.</p>

	Several appliances are connected to one outlet.	The Airfryer has a high wattage. Try a different outlet and check the fuses.
I see some peeling off spots inside my Airfryer.	Some small spots can appear inside the pan of the Airfryer due to the incidental touching or scratching of the coating (e.g. during cleaning with harsh cleaning tools and/or while inserting the basket).	You can prevent damage by lowering the basket into the pan properly. If you insert the basket at an angle, its side may knock against the wall of the pan, causing small pieces of coating to chip off. If this occurs, please be informed that this is not harmful as all materials used are food-safe.

White smoke comes out of the appliance.	You are cooking fatty ingredients and the fat reducer is not put in the pan.	Carefully pour off any excess oil or fat from the pan, place the fat reducer in the pan and then continue cooking.
	The pan still contains greasy residues from previous use.	White smoke is caused by greasy residues heating up in the pan. Always clean the pan, basket and fat reducer thoroughly after every use.
	Breading or coating did not adhere properly to the food.	Tiny pieces of airborne breading can cause white smoke. Firmly press breading or coating to food to ensure it sticks.
	Marinade, liquid or meat juices are splattering in the rendered fat or grease	Pat food dry before placing it in the basket.
My display shows 5 dashes as illustrated in the picture below. 	Safety feature has been activated due to overheating of the appliance.	Unplug the appliance and let it cool down for 1 minute before plugging in again.

Warning

This content is compiled from multiple sources and is provided for reference purposes only. It may not be complete or fully applicable to all situations. If you are unable to resolve your issue, please contact the product manufacturer or an authorized service provider for official support.