

Parts and Features

BEFORE FIRST USE: Unpack processor and remove protective covers from the blade and disc. Handle blade and disc carefully; they are very sharp. Wash all parts except base in hot, soapy water. Rinse; then dry.

US: 1.800.851.8900

www.hamiltonbeach.com

Canada: 1.800.267.2826

Mexico: 01 800 71 16 100

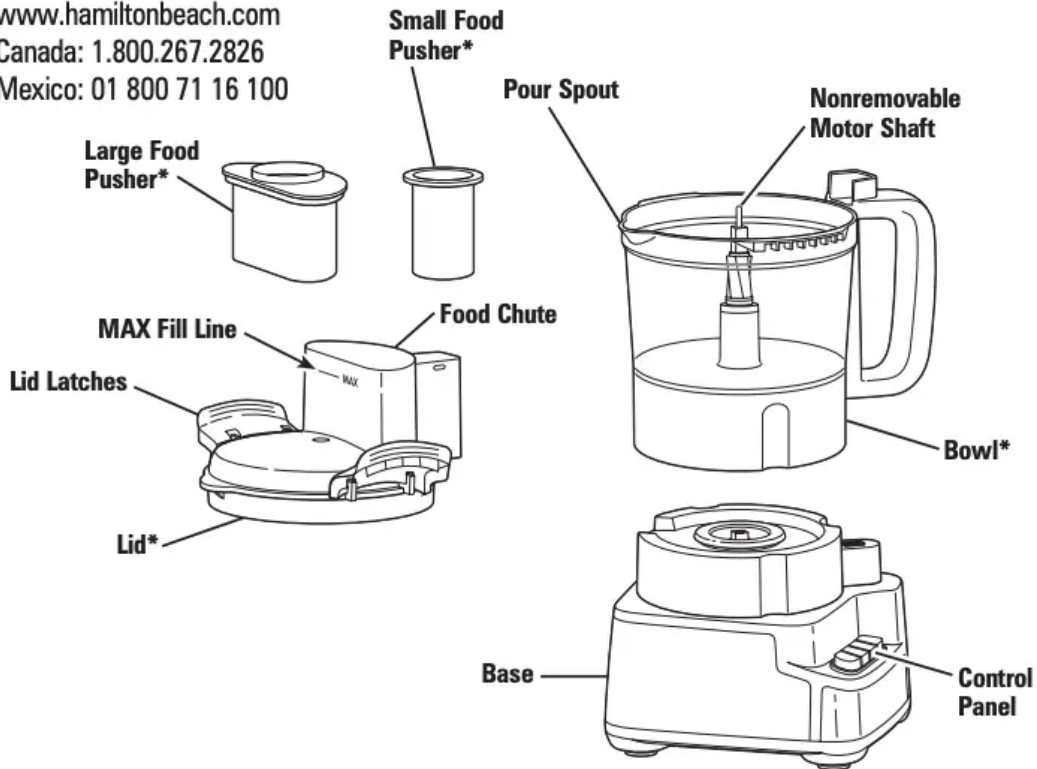

Chopping/Mixing Blade*

Use to coarsely chop, grate, mince, mix, or puree food.



Reversible Slicing/Shredding Disc*

Use to shred or to slice a variety of foods (such as cheese, carrots, onions, tomatoes, peppers, and cucumbers).

How to Use Chopping/Mixing Blade

WARNING Laceration Hazard. Handle blade carefully; it is very sharp. Make sure unit is turned OFF (O) and is unplugged.

NOTE: Operate using only one blade or disc at a time.

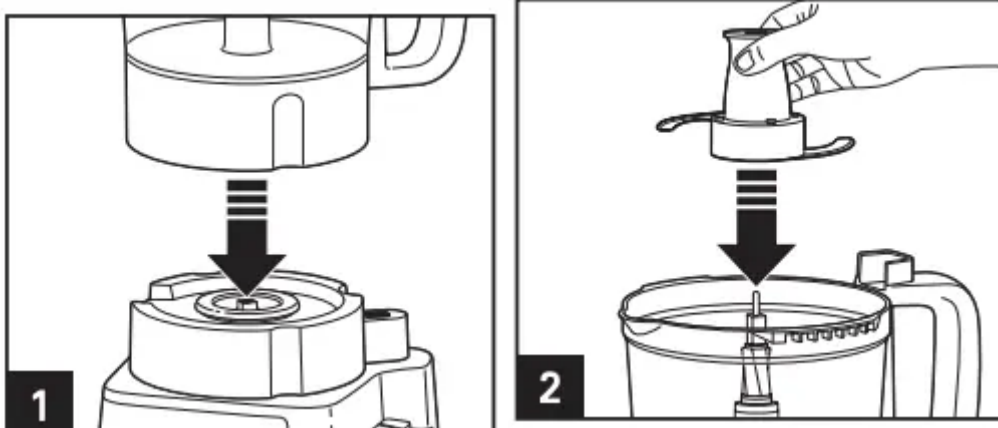

Place bowl on base. Make sure protective cover has been removed from blade to prevent damage and scratches to bowl. Carefully slide blade straight down onto the motor shaft.

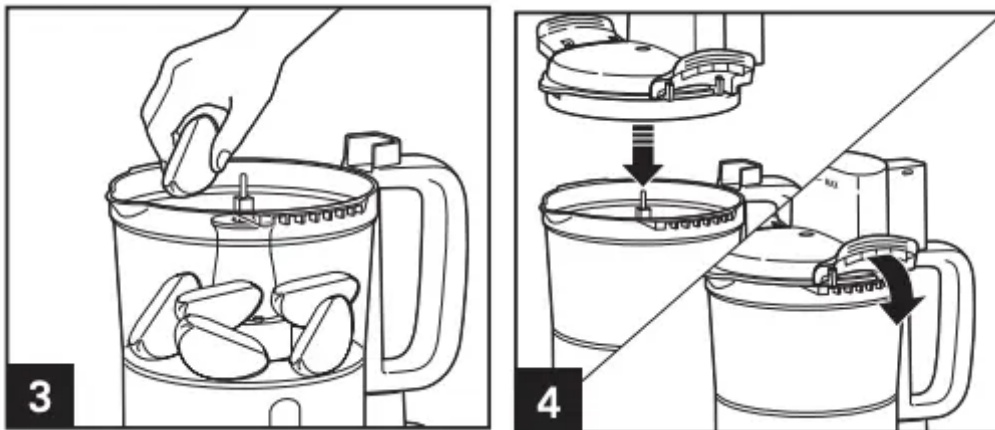

Place lid on bowl, making sure to align the pour spout on the lid with the pour spout on the bowl.

NOTE: Unit will not work unless latches on bowl are locked. Do not force latches to close.

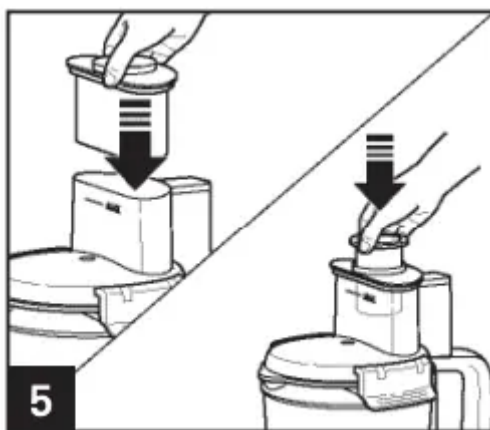

Place food pushers in food chute. **NOTE:** Unit will not operate until large food pusher engages the protective interlock. Do not add food above the MAX fill line.

WARNING Laceration Hazard: Always use food pusher to feed food into the chute. NEVER PUSH FOOD THROUGH CHUTE WITH HANDS OR OTHER OBJECTS.

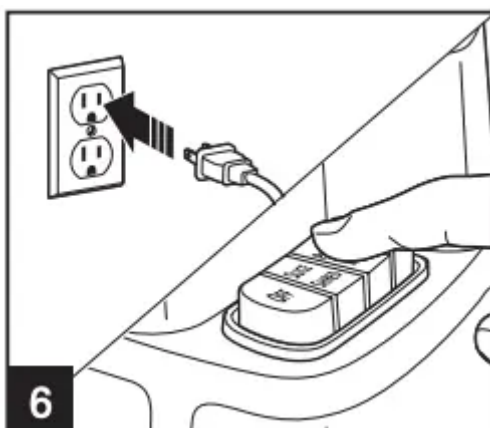

Press desired function button.

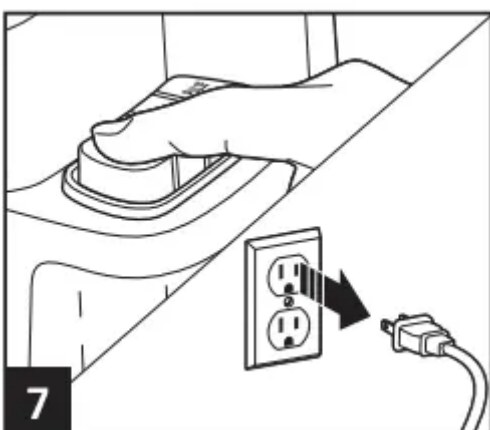

When finished, press OFF (O) and unplug.

WARNING Laceration Hazard: Always unplug unit before removing lid.

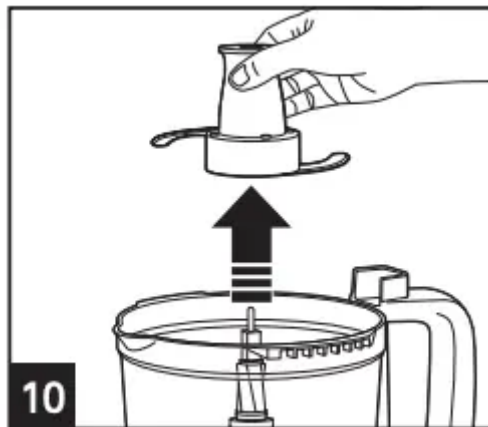
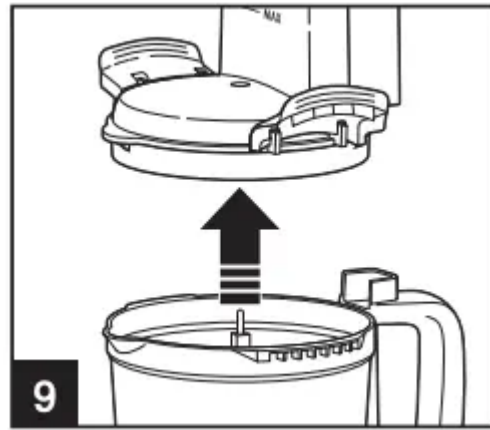
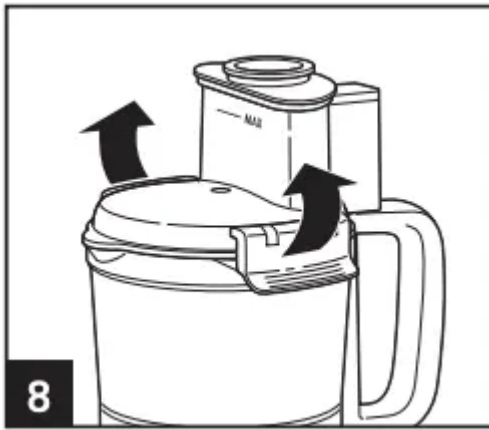

Carefully remove blade from motor shaft.

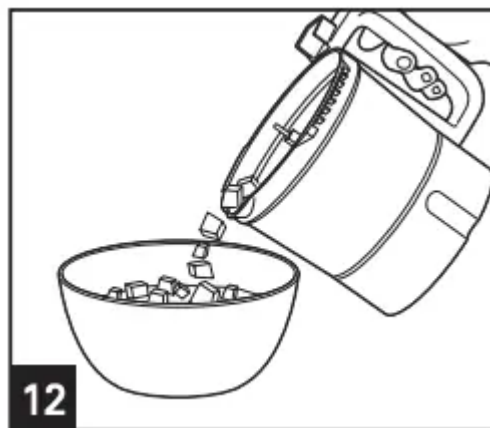
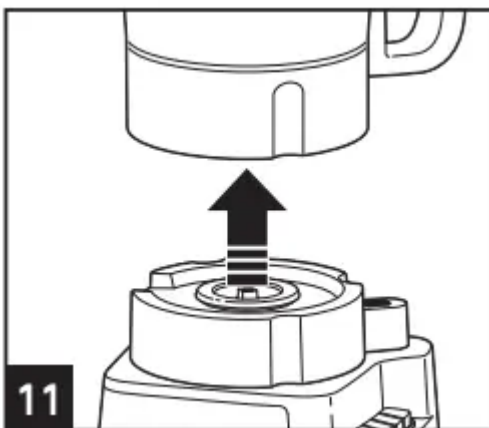

How to Use Reversible Slicing/Shredding Disc

WARNING Laceration Hazard. Handle disc carefully; it is very sharp. Make sure unit is turned OFF (O) and is unplugged.

NOTE: Operate using only one blade or disc at a time.

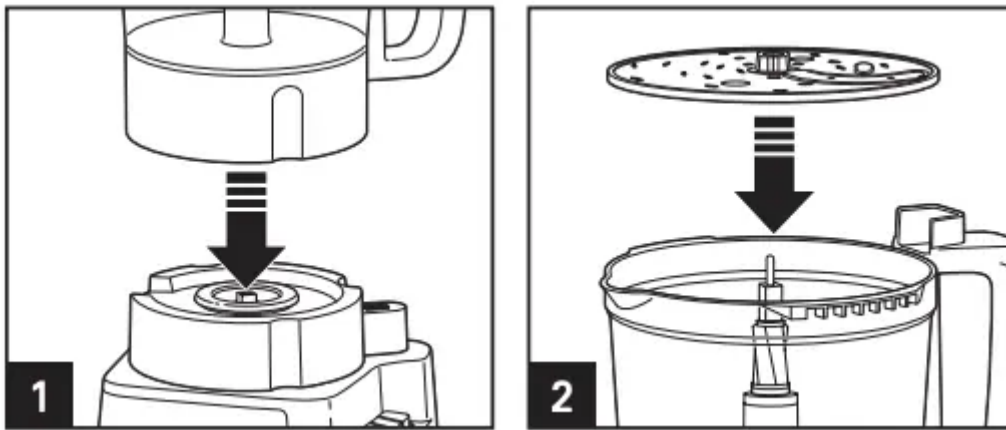

Place bowl on base. Make sure protective cover has been removed from disc to prevent damage and scratches to bowl. Carefully place disc onto motor shaft with desired side facing UP. (“SLICE” or “SHRED” is stamped on each side of the blade.)

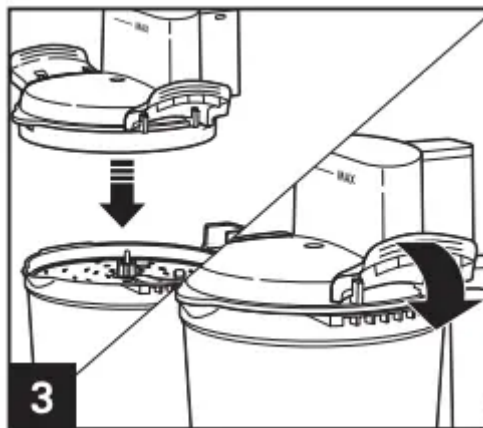

Place lid on bowl, making sure to align the pour spout on the lid with the pour spout on the bowl.

NOTE: Unit will not work unless latches on bowl are locked. Do not force latches to close.

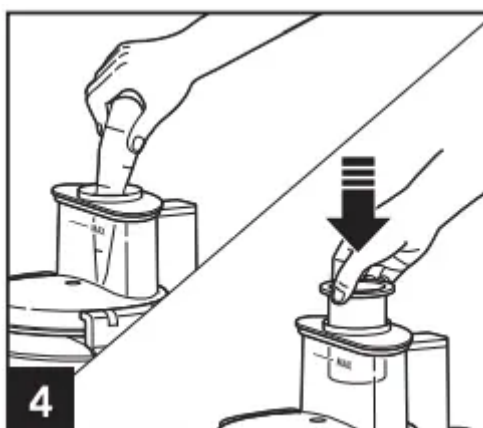

For smaller, thinner foods: Put large food pusher into place. Place food into smaller open tube and use small food pusher to push food in.

NOTE: Soft cheese like mozzarella should be placed in the freezer for 30 minutes prior to processing to ensure it is firm enough for shredding.

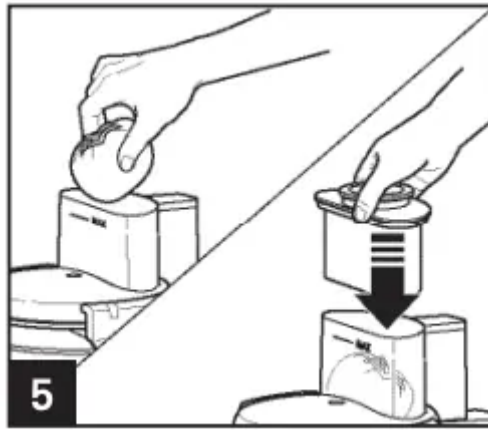

foods using large and small food pushers together. **NOTE:** Unit will not operate until large food pusher engages the protective interlock. Do not add food above the MAX fill line.

WARNING Laceration Hazard: Always use food pusher to feed food into the chute. NEVER PUSH FOOD THROUGH CHUTE WITH HANDS OR OTHER OBJECTS.

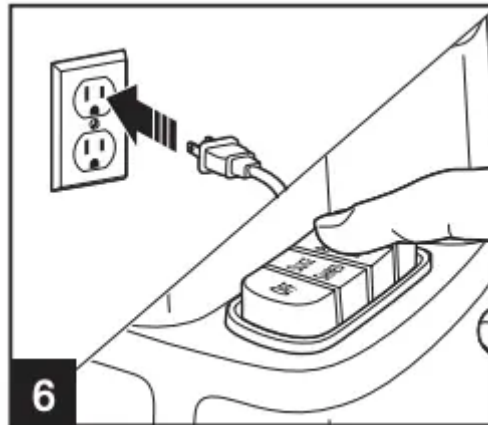

Press desired function button.

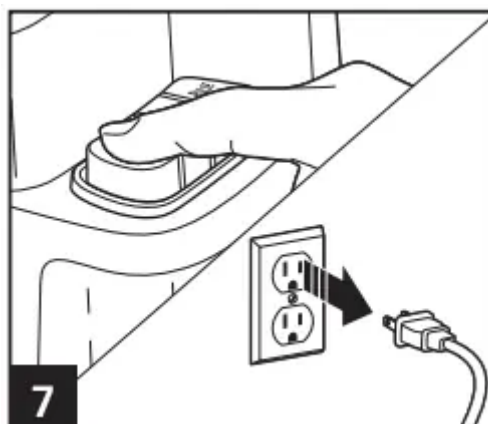

When finished, press OFF (O) and unplug.

WARNING Laceration Hazard: Always unplug unit before removing lid.

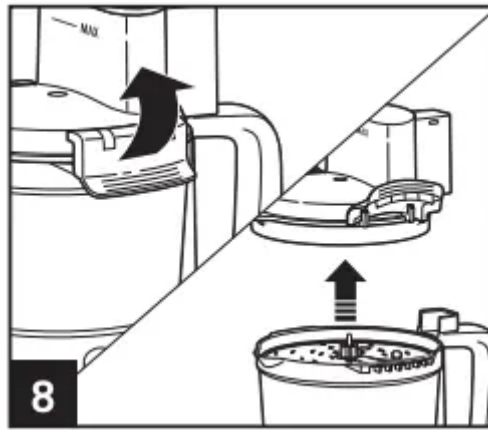

Always remove lid before removing bowl to avoid possible damage to the appliance.

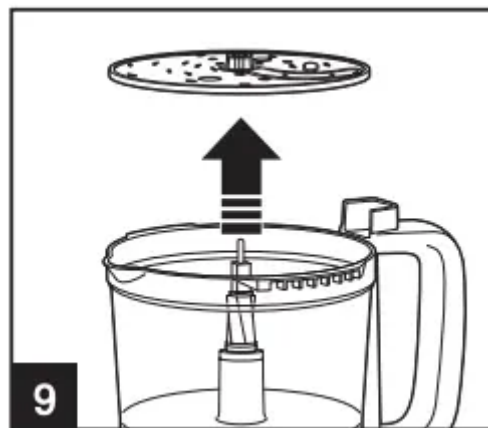

Carefully remove disc from motor shaft.

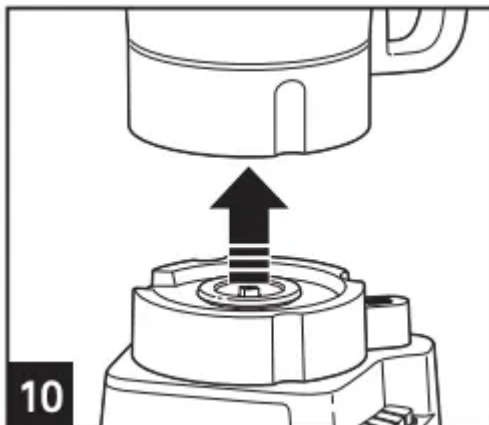

Tips and Techniques

- For a more uniform consistency, start with pieces of food that are similar in size. Cut food into 1-inch (2.5-cm) pieces before processing with chopping/mixing blade and leave room in bowl for the food to be tossed around.

- This food processor is excellent to chop, mix, slice, or shred most foods. However, to maintain peak performance, do not use your food processor for the following: grinding grain, coffee beans, or spices; slicing frozen meats; kneading dough; or crushing ice.
- When chopping foods, pulsing on and off will produce the best results.
- Operating time will depend on quantity of food being processed. Most foods can be sliced, chopped, or shredded in seconds. If unit is operated continuously for an extended period of time, let the processor rest about 4 minutes before continuing.
- Do not puree or mash starchy vegetables like potatoes as they are easily overprocessed and will become gummy.
- To slice or shred cheese, use only firm cheese like Cheddar or Swiss that has been chilled for at least 30 minutes. Cheese should be processed immediately after being removed from the refrigerator. Soft cheese like mozzarella should be placed in the freezer for 30 minutes prior to processing to ensure it is firm enough for shredding.
- The reversible slicing/shredding disc has a slicing blade on one side and shredding teeth on the other. The name stamped on the blade, facing up, is the function selected. Place on motor shaft with desired cutting edge facing up.
- To julienne vegetables, slice and then remove from bowl. Restack the vegetables. Pack into food chute with slices vertical. Slice again to make matchstick-cut vegetables.

Processing Charts

Disc attachments are reversible and labeled. The label should face up for the desired function. When using disc attachments, do not process past the MAX LEVEL on the bowl.

ATTACHMENT	FOODS
Chopping/Mixing Blade	<p>Chop: nuts, meat, garlic, onions, peppers, celery, herbs, bread (for crumbs), crackers</p> <p>Mince/Puree: vegetables, fruit</p> <p>Mix: salad dressings</p> <p>Puree: soups, sauces</p> <p>Grate: cheese, such as Parmesan (chilled)</p>
Slicing Disc (slicing side facing UP)	Cucumbers, apples, mushrooms, carrots, potatoes, cabbage, tomatoes, pepperoni, peppers, radishes, firm cheeses (chilled)
Shredding Disc (shredding side facing UP)	Cabbage, potatoes, carrots, cheese (chilled)

For best results do not exceed the following amounts when chopping, mincing, or pureeing with the chopping/mixing blade. Leave some space in the bowl to allow ingredients to move for pulsing or blending.

FOOD	MAXIMUM AMOUNT TO PROCESS
Dry ingredients such as crackers or nuts	12 cups (2.8 L)
Vegetables or fruits	3 pounds (1.4 kg)
Cheese such as Parmesan or Cheddar	40 ounces (1.2 L)
Thick sauces or dips	8 cups (1.9 L)
Liquids such as marinades or soups	7 cups (1.7 L)

Care and Cleaning

WARNING Electrical Shock Hazard. Disconnect power before cleaning. Do not immerse cord, plug, or base in any liquid.

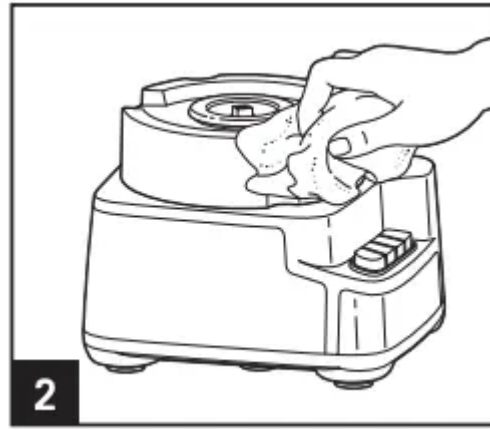
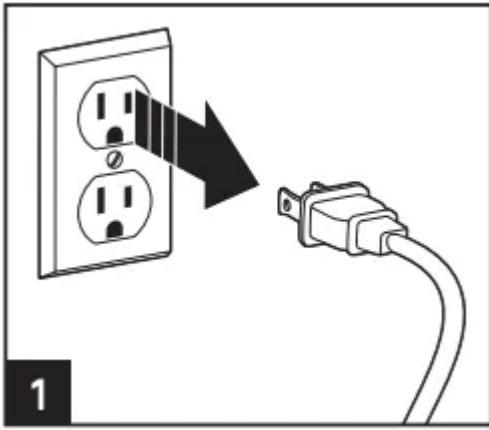

Wipe base, control panel, and cord with a damp cloth or sponge. If necessary, use a mild nonabrasive cleanser.

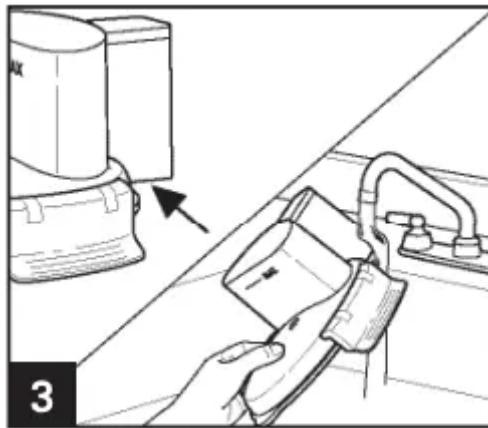

NOTE: If food particles get trapped in the back of the food chute above the handle, place area under running water to rinse pieces out before putting in the dishwasher.



DO NOT use the “SANI” setting when washing in the dishwasher. “SANI” cycle temperatures could damage your product. All removable parts may also be cleaned in the sink with hot, soapy water. Use caution when washing chopping/mixing blade and slicing/shredding disc.

Troubleshooting



PROBLEM	PROBABLE CAUSE
<p>Unit does not operate on any speed or Pulse.</p>	<ul style="list-style-type: none"> • Is the unit plugged in? Does the outlet work? • Is the lid latched in place? See “How to Use” sections. Place lid on bowl, making sure to align the pour spout on the lid with the pour spout on the bowl. • Is the large food pusher in the chute? The large food pusher must be in place to operate. • Is the food chute overfilled? Do not add food above the MAX fill line. The large food pusher must be in the food chute to operate.
<p>Food is not sliced or shredded uniformly.</p>	<ul style="list-style-type: none"> • Packing too much food in the food chute or pushing too hard on the food pusher may cause the processed food to be irregularly sliced or shredded. Refer to the Food Processing Charts for recommended sizes and quantities.
<p>Unit stops and will not come back on.</p>	<ul style="list-style-type: none"> • Is the lid latched in place? See “How to Use” sections. Place lid on bowl, making sure to align the pour spout on the lid with the pour spout on the bowl. • Is the outlet still working? Check it by plugging in a working lamp or other appliance. You may have overloaded the circuit and blown a fuse or tripped the circuit breaker. • Turn unit OFF (O), allow to stand for 3 to 4 minutes, and then turn back on. • If none of these suggestions correct the problem, DO NOT attempt to repair the unit. Call the Customer Service number.
<p>Unit has a burning smell.</p>	<ul style="list-style-type: none"> • There may be a residue left on the motor from the manufacturing process, causing a slight odor during initial use. This will go away. If a strong odor or any visible smoke appears, unplug unit IMMEDIATELY and call the Customer Service number.
<p>Motor seems weak.</p>	<ul style="list-style-type: none"> • Are you using the recommended food size and quantity to be processed? Refer to the Food Processing Charts for recommended food sizes and speeds.



<p>Cheese is not shredding well.</p>	<ul style="list-style-type: none"> • Cheese should be processed immediately after being removed from the refrigerator. Soft cheese like mozzarella should be placed in the freezer for 30 minutes prior to processing to ensure it is firm enough for shredding.
<p>Vegetables are not shredding or slicing.</p>	<ul style="list-style-type: none"> • Store vegetables with high water content in the refrigerator prior to processing. Room-temperature vegetables are less firm and do not perform as well.
<p>Food particles stuck in the back of the food chute above the handle.</p>	<ul style="list-style-type: none"> • Place back of the food chute under running water to rinse out the food before placing in the dishwasher.

Recipes

Roasted Red Pepper Hummus

- 2 cloves garlic
- 2 green onions, white portion and half of green tops
- 1 can (15 oz./425 g) garbanzo beans (chickpeas), drained
- 1 jar (14 oz./397 g) roasted red peppers, drained
- 1/4 cup (59 ml) tahini (sesame paste), stirred
- 2 tablespoons (30 ml) lemon juice
- 2 teaspoons (10 ml) olive oil
- 1/4 teaspoon (1.3 ml) ground cumin
- Dash cayenne pepper
- Salt and pepper to taste
- Dash paprika
- Pita chips or cut vegetables

Directions

1. Using S-blade and with processor running, drop garlic cloves and onion into food chute.
2. Add garbanzo beans, roasted red peppers, tahini, lemon juice, olive oil, cumin, cayenne, salt and pepper. Continue to process until smooth.
3. Place in serving bowl and garnish with paprika.
4. Serve with pita chips and/or vegetables. Refrigerate to store.

Serves: 4 to 6

Fresh and Spicy Salsa

- 1 onion, peeled
- 1 clove garlic
- 1 hot pepper (jalapeno or finger hot), cored, seeded, and quartered
- 4 tomatoes, quartered
- 1/4 cup (59 ml) cilantro, packed
- 1/2 teaspoon (2.5 ml) cumin
- 1 tablespoon (15 ml) lime juice
- Salt and pepper to taste
- Hot sauce, optional

Directions

1. Using S-blade and with processor running, drop onion, garlic clove and hot pepper through the food chute and chop until finely minced. Scrape bowl as needed.
2. Add tomatoes, cilantro, cumin, lime juice, salt and pepper. Pulse until desired texture, scraping bowl as needed. Add hot sauce if desired.

Serves: 6 to 8

Cilantro Butter

- 1 bunch cilantro
- 1 cup (237 ml) unsalted butter, softened
- Juice from one lemon
- Salt and pepper to taste

Directions

1. Wash cilantro and separate leaves from stems. Combine butter and cilantro leaves in food processor. Blend until light and fluffy.
2. Add lemon juice, salt, and pepper to taste. Process to blend.
3. Use for grilled dishes. Delicious with grilled salmon, swordfish or tuna. Refrigerate to store.

Serves: 4 to 6

Cajun Veggie Gratin

- 3 medium zucchini, sliced in food processor
- 1 red onion, sliced in food processor
- 6 plum tomatoes, sliced in food processor

- 2 teaspoons (10 ml) extra virgin olive oil
- 1 1/2 teaspoons (7.5 ml) Cajun seasoning
- 1 teaspoon (5 ml) salt
- 1 teaspoon (5 ml) freshly ground pepper

Cooking spray

Topping:

- 1 cup (237 ml) bread crumbs
- 1/2 cup (118 ml) parmesan cheese, chopped finely in food processor
- 1/2 teaspoon (2.5 ml) Cajun seasoning

Directions

1. Heat oven to 425°F (218°C). Spray 8-in. (20-cm) square baking pan with cooking spray.
2. Heat oil in large sauté pan over medium heat.
3. Add sliced zucchini and onion and sauté for 3 to 4 minutes until beginning to soften.
4. Add sliced tomatoes, Cajun seasoning, salt and pepper to pan.
5. Sauté mixture, stirring gently, for 8 to 10 minutes until all vegetables are softened and heated through. Place vegetable mixture in prepared pan.
6. Combine bread crumbs, Parmesan cheese and Cajun seasoning. Sprinkle evenly over top of vegetables.
7. Bake 15 to 20 minutes or until topping is brown and crispy.

Serves: 8

Bleu Cheese Dressing

- 1 clove garlic
- 8 ounces (227 g) blue cheese
- 1 cup (237 ml) mayonnaise
- 1/2 cup (118 ml) milk
- 1/2 cup (118 ml) sour cream
- 1/4 cup (59 ml) white vinegar
- 1 teaspoon (5 ml) Worcestershire sauce
- 1 teaspoon (5 ml) sugar
- 1/2 teaspoon (2.5 ml) salt
- 1/4 teaspoon (1.3 ml) black pepper

Directions

1. Using S-blade and with processor running, drop garlic clove into the food chute and mince.
2. Add blue cheese and process for 10 seconds.
3. Add remaining ingredients. Process until blended, but still chunky.

Serves: 8 to 10

Cranberry Orange Relish

- 12 oz. (340 g) cranberries (fresh with stems removed, or frozen)
- 1 cup (237 ml) sugar
- 1 small navel orange, washed, cut into wedges
- 3 tablespoons (44 ml) Grand Marnier® liqueur or orange juice
- Dash of ground cloves

Directions

1. Using S-blade, place cranberries, sugar, orange, Grand Marnier® or orange juice and cloves into the work bowl.
2. Process until cranberries are almost smooth, yet a bit chunky.
3. Cover and refrigerate overnight.

Serves: 8 to 10

Warning

This content is compiled from multiple sources and is provided for reference purposes only. It may not be complete or fully applicable to all situations. If you are unable to resolve your issue, please contact the product manufacturer or an authorized service provider for official support.