



Download the App



To set up, download the **My Mesh** app for iOS and Android.

The app will walk you through the setup.

Download My Mesh for mobile device

 A green square icon with a white Wi-Fi signal symbol.	Search My Mesh in App Store or Google Play. Download My Mesh app
 A black and white QR code.	Or scan the QR code to download.

Hardware Connection

Connect the main mesh point to modem ethernet port.

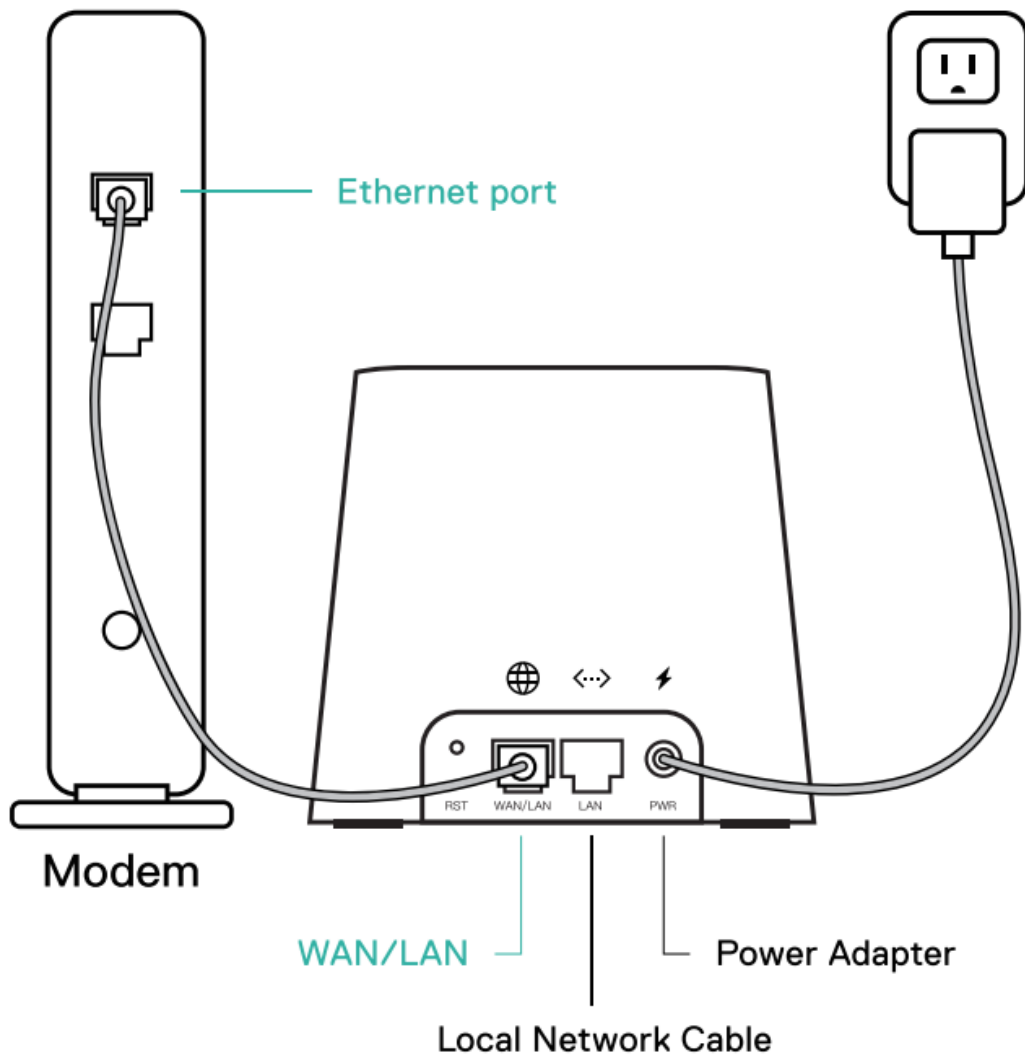

Connect to Default WiFi

Connect your mobile phone to the default WiFi. WiFi name and password are printed on the bottom label of the main mesh point.





SSID:
MyMesh_XXXXXX
Password:
XXXXXXXX

Note: The default WiFi password printed on the label is case sensitive.

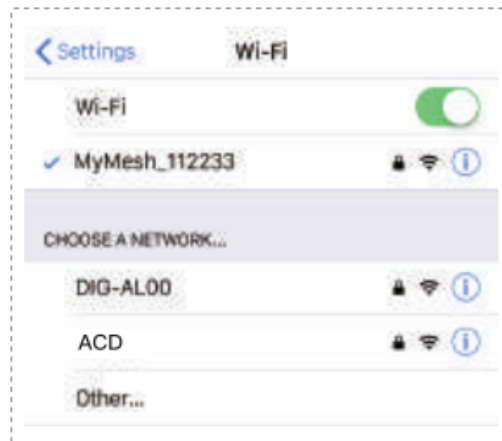

Having trouble? If you did not see the default WiFi on your mobile phone, try to disable phone WiFi and re-enable it.

Setup in the App

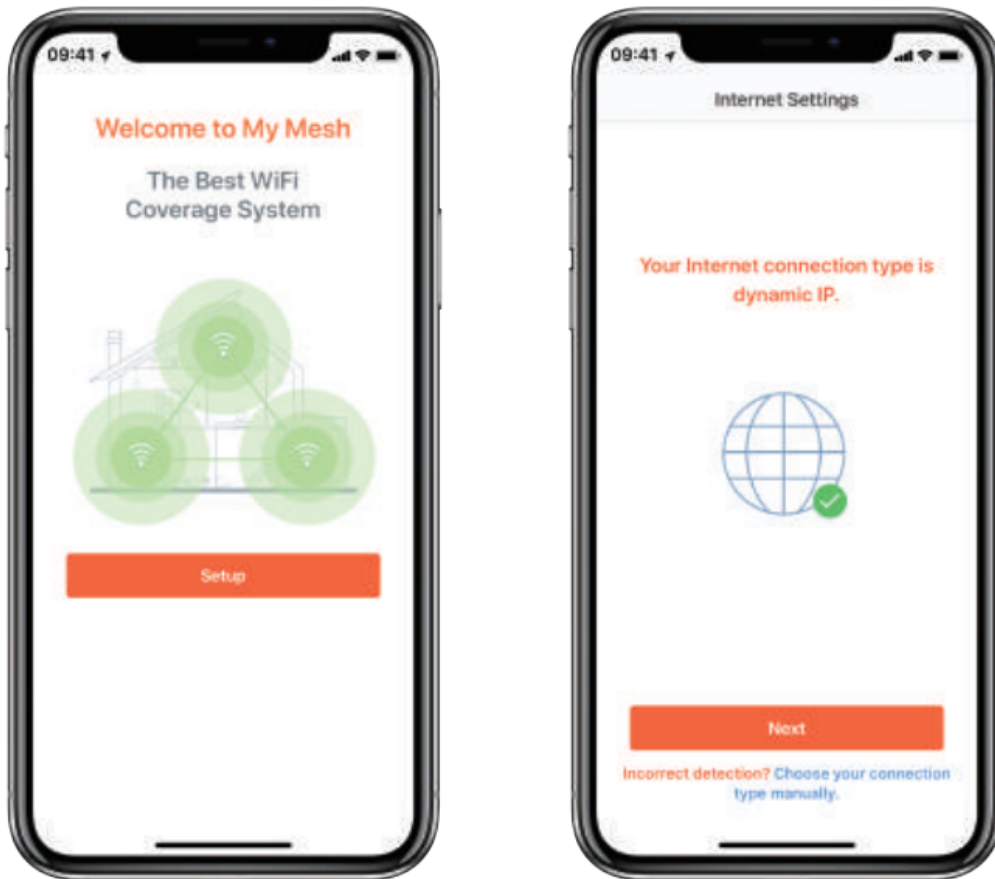

Step 1

After your mobile phone is connected to the default WiFi, go to the app and wait for a few seconds. Tap **Setup** button to start.

Step 2

Your connection type should be detected automatically. If not, see page 10.

Step 3

Name your personal WiFi name and password to replace the default.



- ✓ Tap OK and wait for a while, now your main mesh point setup is complete.

Extend WiFi Range with Dots

MeshForce M3 Dot is designed to extend the range. You can add up to 6 dots, each dot can fulfill 1-2 rooms coverage.

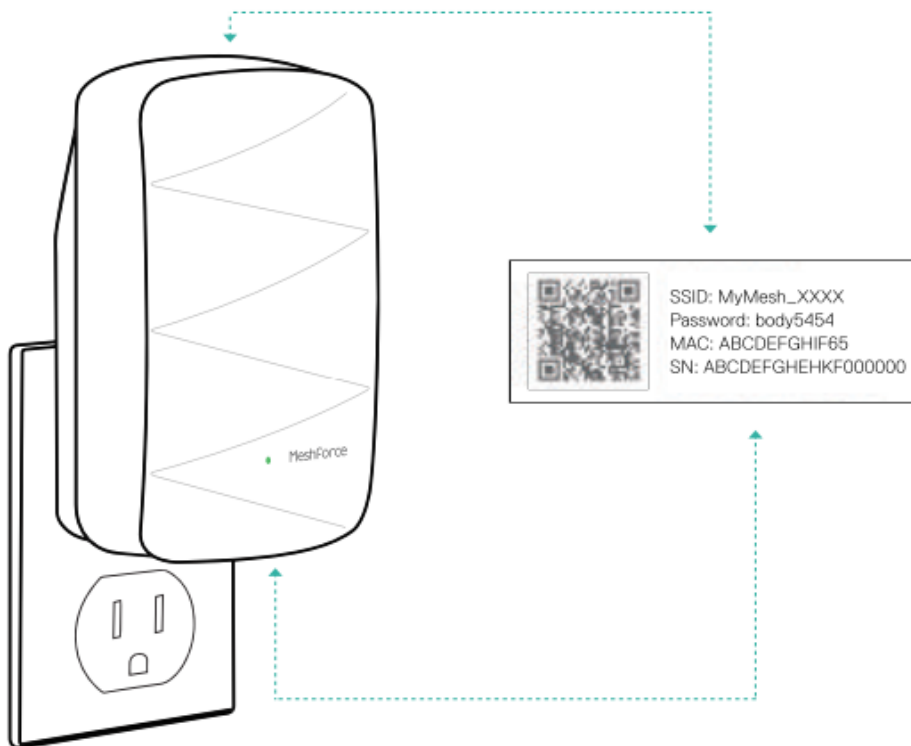



Simply plug your M3 Dot and wait for about 1 minute until the indicator turns solid green. It will pair with your main mesh point automatically. If not, go to the app, **Settings - Add a Mesh**, scan the QR code to add manually.

Note:

- Place mesh points within 10 meters or 2 rooms away between each other. Keep away from microwave oven or refrigerator.
- All the mesh points and dots are for indoor use only.

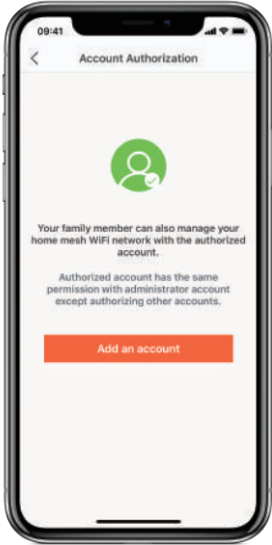
Manage WiFi Remotely

	<ol style="list-style-type: none">1.  Click  on the homepage up-right corner, register and sign in by Email, or Google, Facebook, Twitter account.2. To add family members manage the mesh WiFi, go to Settings - Account Authorization. Type in his or her ID displayed in the profile page.
-----------------------------------------------------------------------------------	-------------------------------------------------------------------------------------------------------------------------------------------------------------------------------------------------------------------------------------------------------------------------------------------------------------------------------------------------------------------------------------------------------------------------------------------------------------------------------------------------

Note:

- The family members you want to add must register a My Mesh account.
- Account authorization feature is visible for WiFi admin only.

Create Guest Network

Create a temporary and isolated WiFi for your guests.

Go to **Settings - Guest Network** to create.

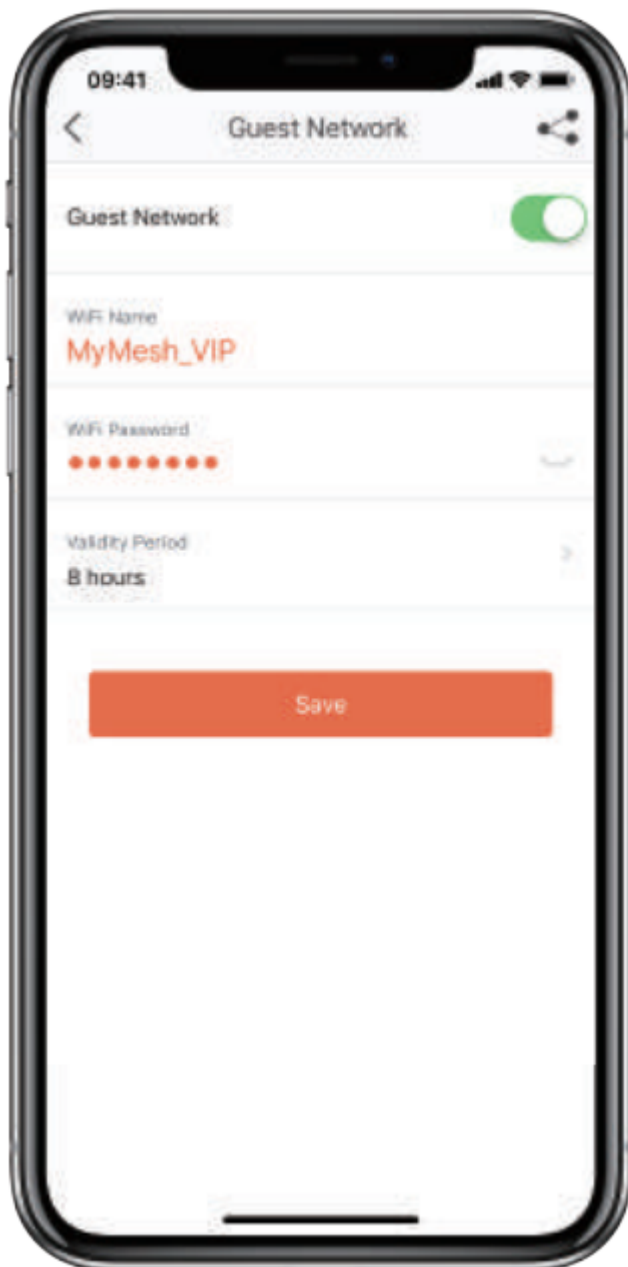

Reset and Diagnostics

If you need to reset the mesh, use a sharp item (like pen) press the **RST** button for **10 seconds**, until the **LED** indicator blinks green rapidly.

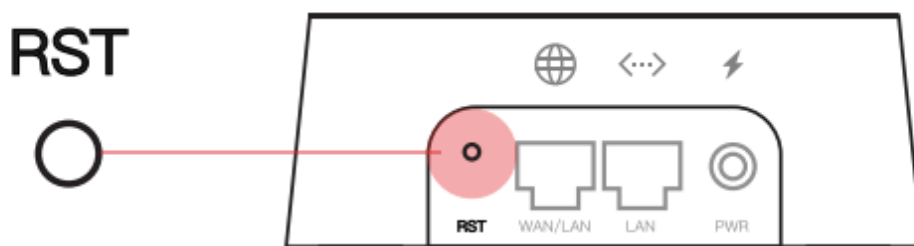

LED	Status	Take action
Green Solid	Internet connection is good.	
Green Pulse	Product is ready to setup	Connect WiFi, go to the App and setup the mesh. If add as additional points, go to the App add a mesh.
	Product reset successfully	
Yellow Solid	Internet connection is fair	Place closer to the main mesh point
Red Solid	Setup is failed or time out	Go to the App check error message, reset the point to start over.
	Unable to connect to the Internet	Check internet service status with your ISP
If the app failed to detect, please choose your connection type manually.		
Type	Description	
PPPOE	Applicable to use if your ISP provided PPPOE username and password.	
DHCP	Obtain IP address automatically. If your Internet configuration is set in the modem, choose DHCP mode. (Applies for most users)	
Static IP	Ask configurations from your ISP if you are using static IP.	

Warning

This content is compiled from multiple sources and is provided for reference purposes only. It may not be complete or fully applicable to all situations. If you are unable to resolve your issue, please contact the product manufacturer or an authorized service provider for official support.

