

User Guide Electronic Keypad

264 Electronic Deadbolt

1. Prepare the door and check dimensions

If drilling a new door, use the supplied template and the complete door drilling instructions available at www.kwikset.com/doorprep.

A Measure to confirm that the hole in the door is either 2-1/8" (54 mm) or 1-1/2" (38 mm).

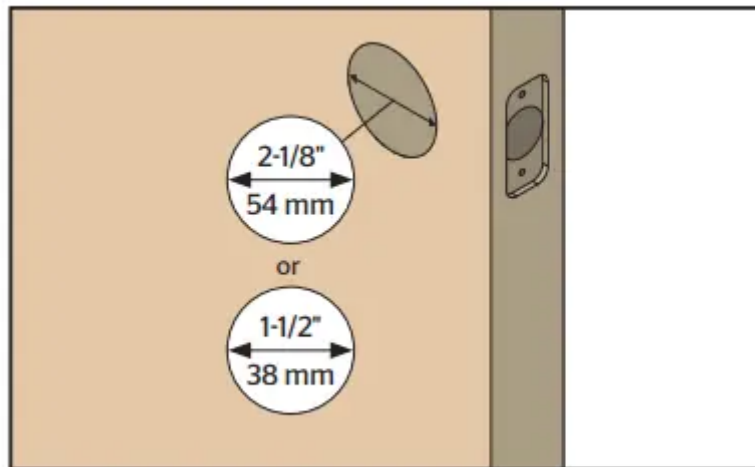

Note: Additional door preparation may be required for doors with 1-1/2" (38 mm) holes. Consult the deadbolt drilling instructions at www.kwikset.com/doorprep

B Measure to confirm that the backset is either 2-3/8" or 2-3/4" (60 or 70 mm).

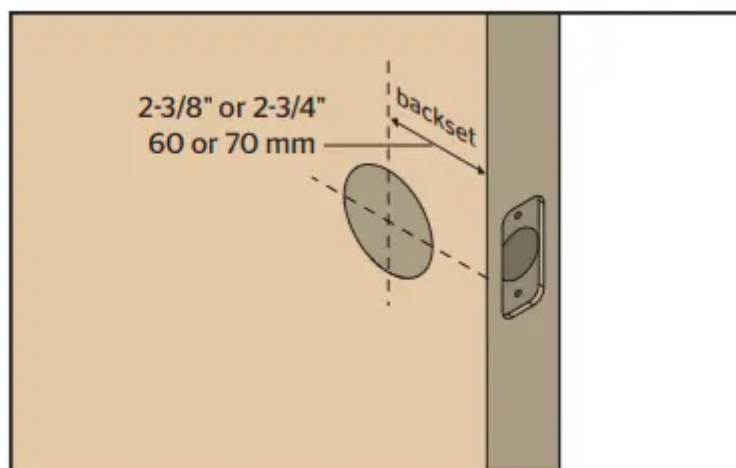

C Measure to confirm that the hole in the door edge is 1" (25 mm).

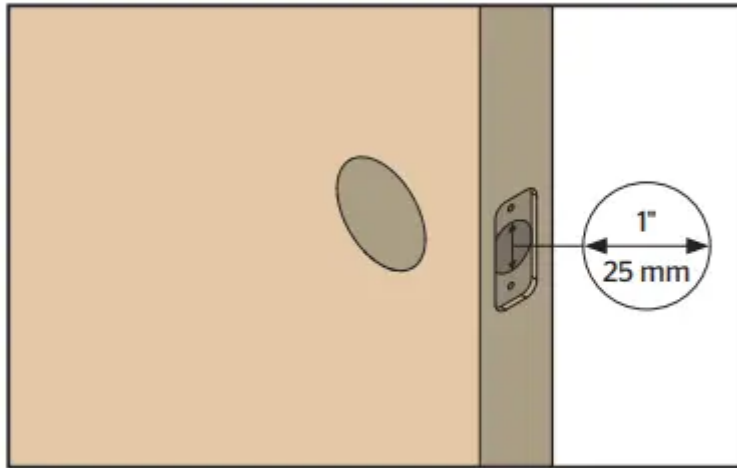

D Measure to confirm that the door is either 1-3/8" or 1-3/4" (35 mm or 44 mm) thick.

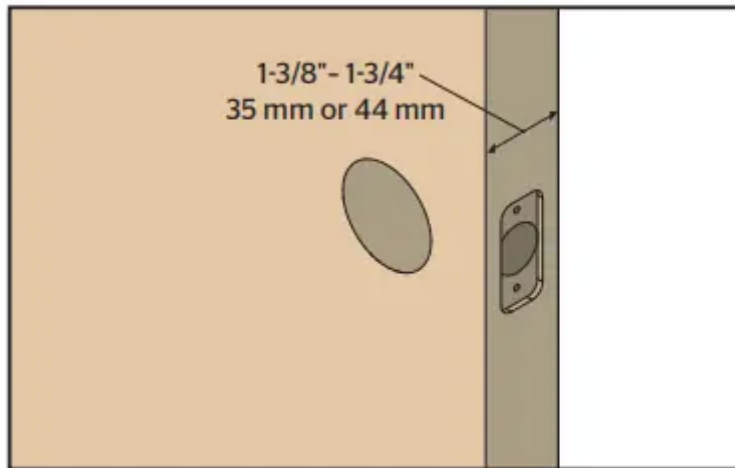

1. Install the latch and strike

A Hold the latch in front of the door hole, with the latch face flush against the door edge.

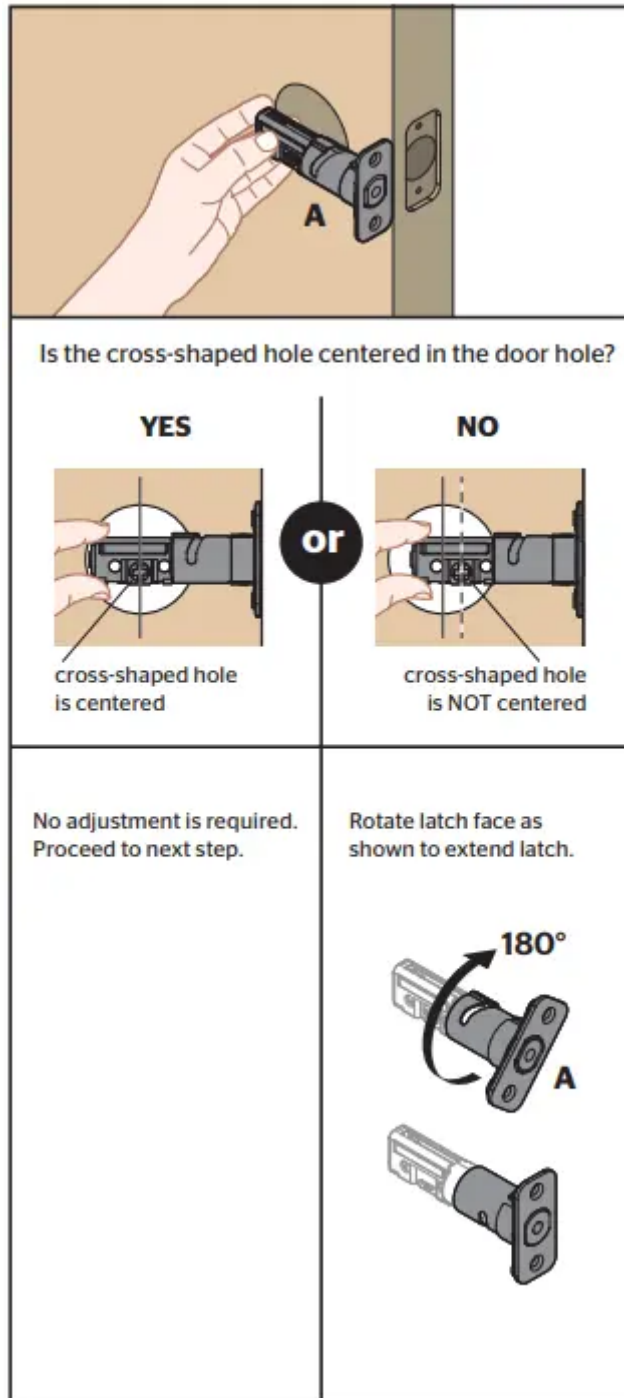

B Hold the latch in front of the door hole, with the latch face flush against the door edge.

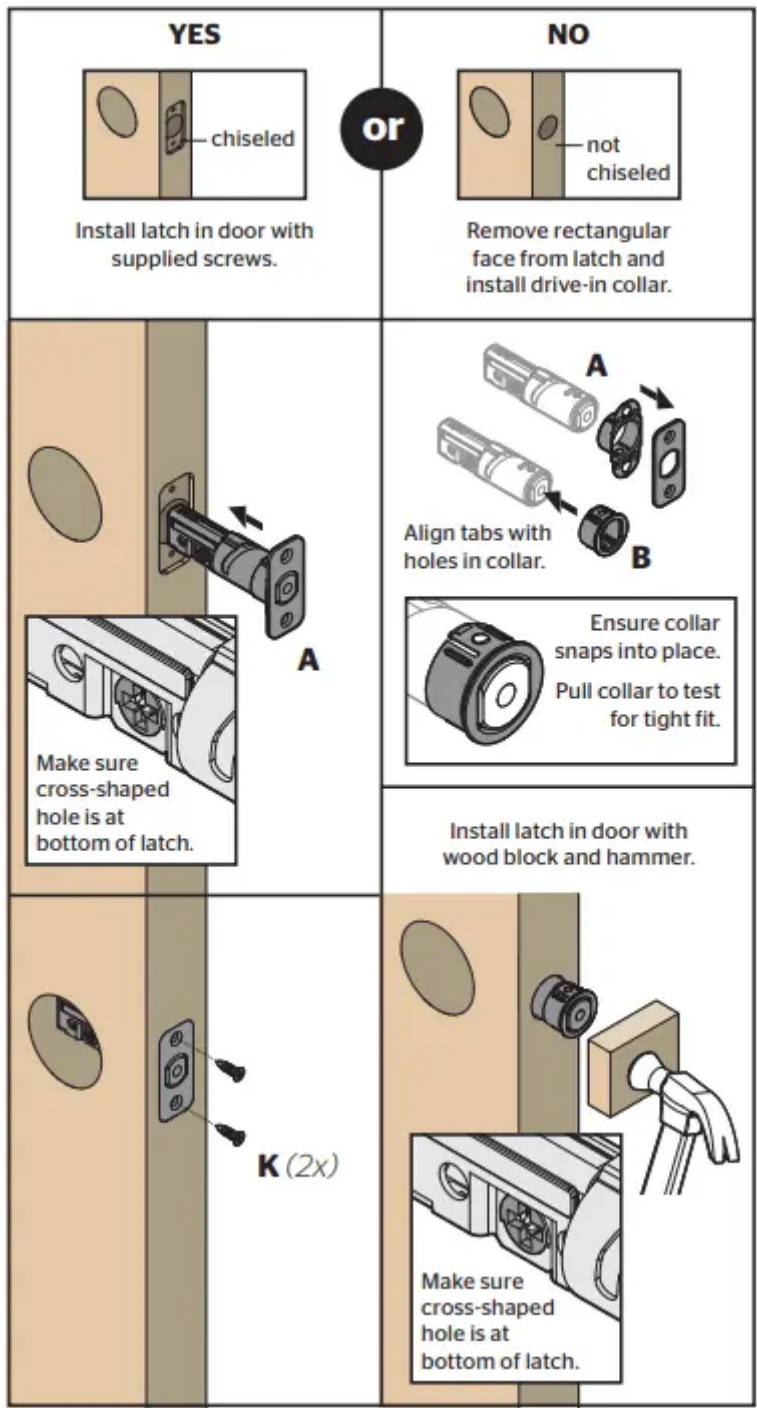

C Hold the latch in front of the door hole, with the latch face flush against the door edge.



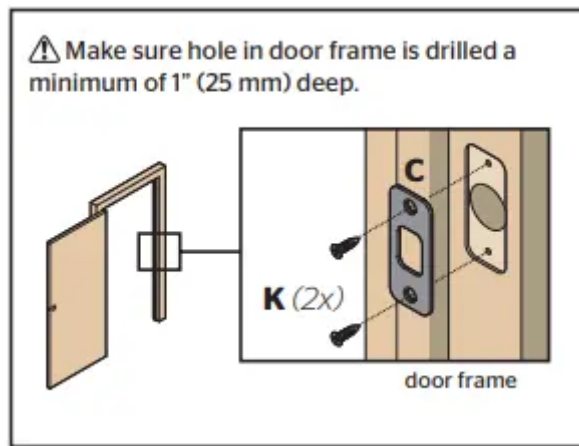

D Make sure the latch bolt is fully retracted (in the unlocked position).

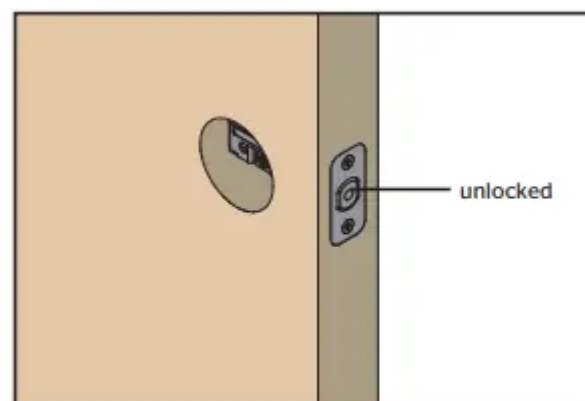

1. Prepare keypad and mounting plate (only for doors with smaller holes)

What is the diameter of the hole in the door?

Diameter is 2-1/8" (54 mm)

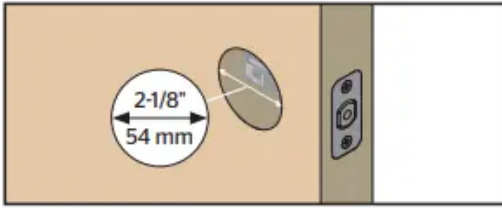

Diameter is 1-1/2" (38 mm)

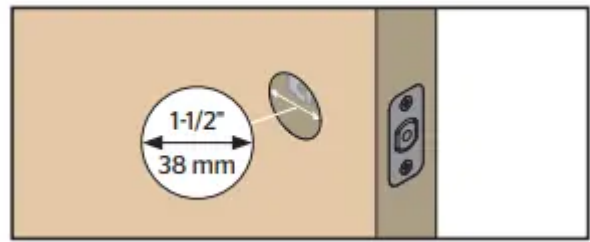

No adjustment is required. Proceed to step 4.

A Remove adapter ring from exterior assembly:

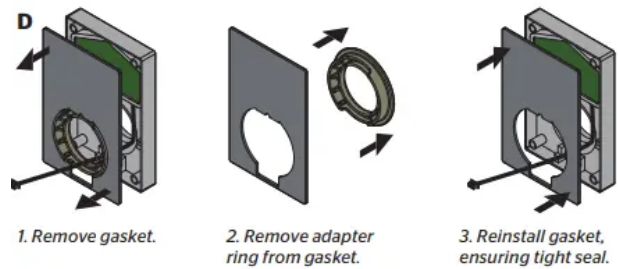

B Use pliers to remove two tabs from mounting plate:

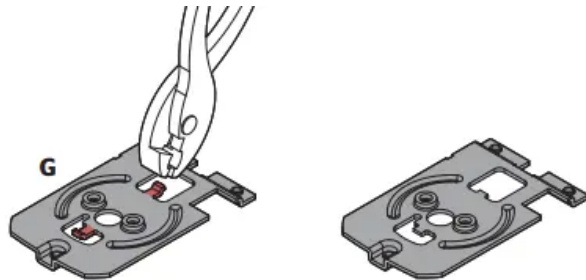

1. Install the exterior assembly

A Install the cylinder into the exterior assembly.

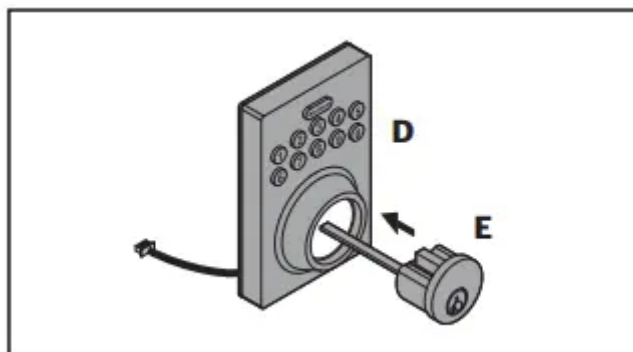

B Install the cylinder into the exterior assembly.

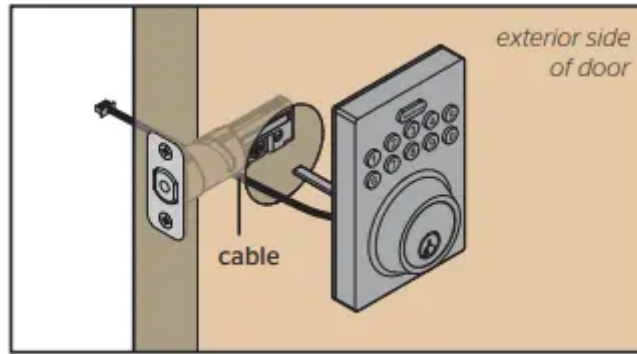

C IMPORTANT: Make sure the latch is fully retracted (in the unlocked position).

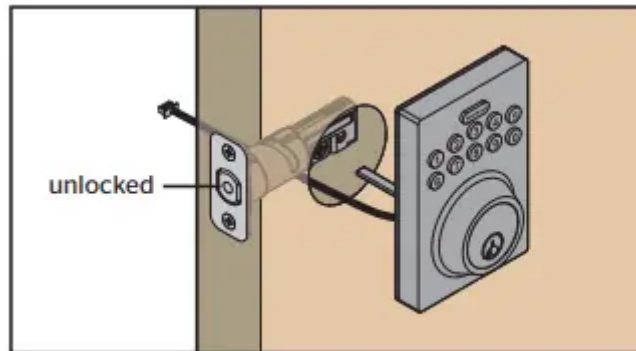

D IMPORTANT: Make sure the torque blade is in the horizontal position.

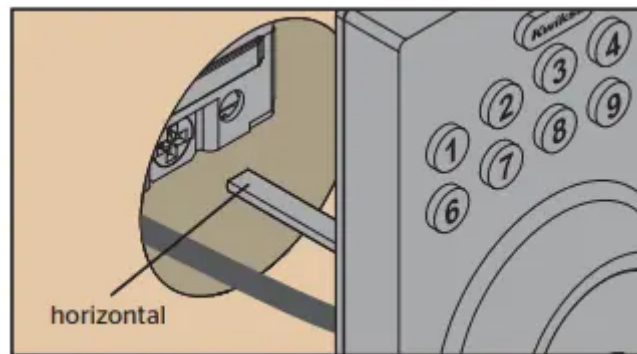

E Insert the torque blade through the horizontal slot of the cross-shaped hole.

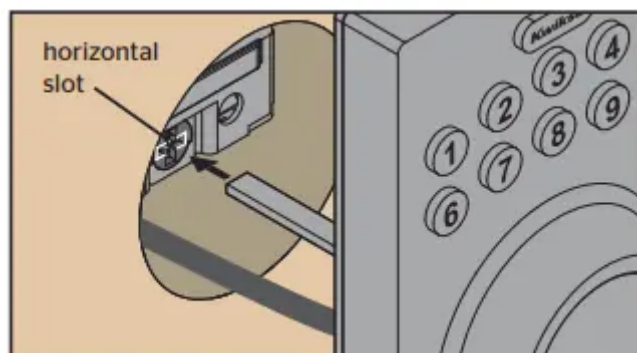

F Push the torque blade through the center hole in the mounting plate and send the cable through the bottom hole.

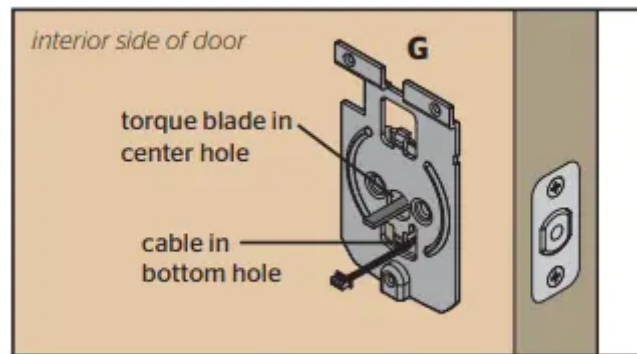

G Push the torque blade through the center hole in the mounting plate and send the cable through the bottom hole.

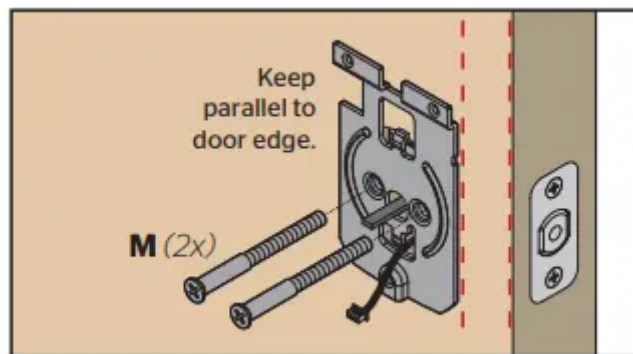

H Insert the key and test the latch for smooth operation.

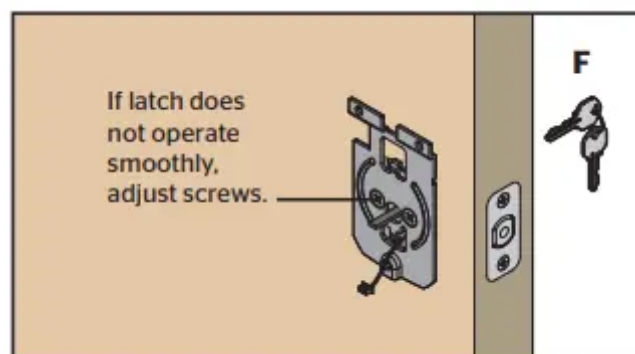

I Remove the key and make sure the latch bolt is still in the unlocked position.

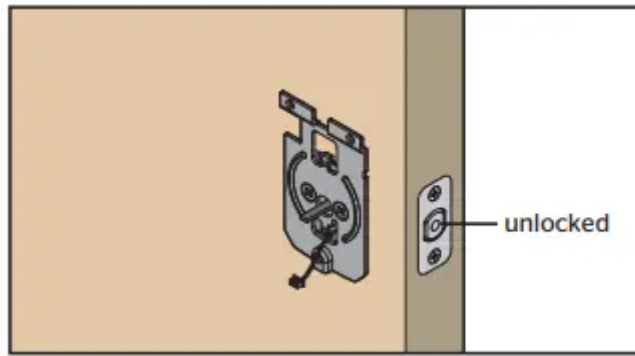

1. Install interior assembly

A Remove the battery cover

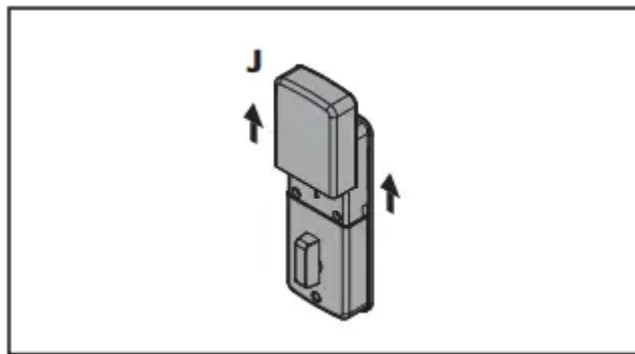

B Load 4 AA batteries into the interior assembly. For best results, use new, non-rechargeable Alkaline batteries only

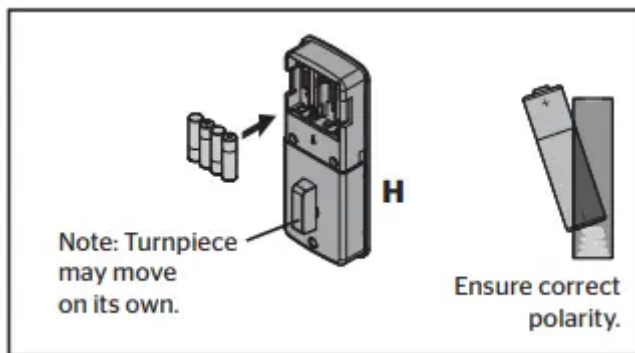

C Press and hold the Reset button on the interior assembly for 5 seconds, until you hear 3 beeps

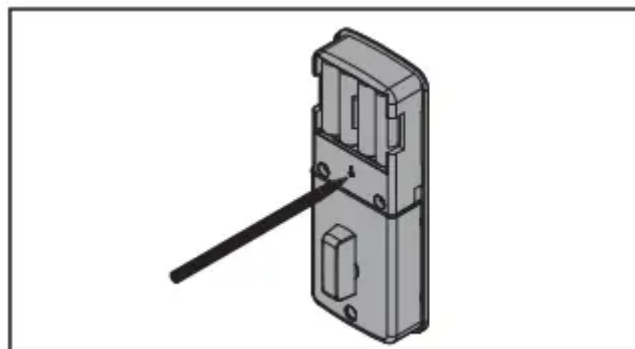

D Press and hold the Reset button on the interior assembly for 5 seconds, until you hear 3 beeps

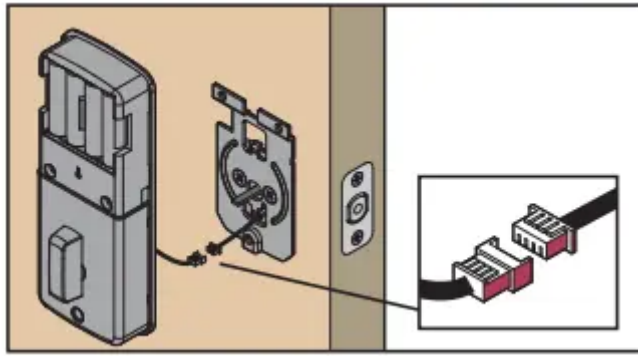

E IMPORTANT: Rotate the turnpiece AWAY from the door edge.

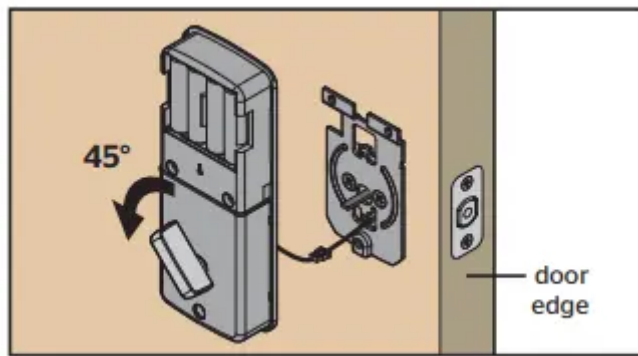

F Make sure the torque blade is still in the horizontal position and install the interior assembly.

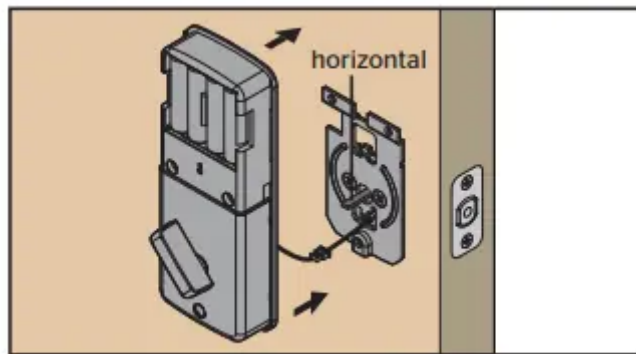

G Test the turnpiece for smooth rotation.

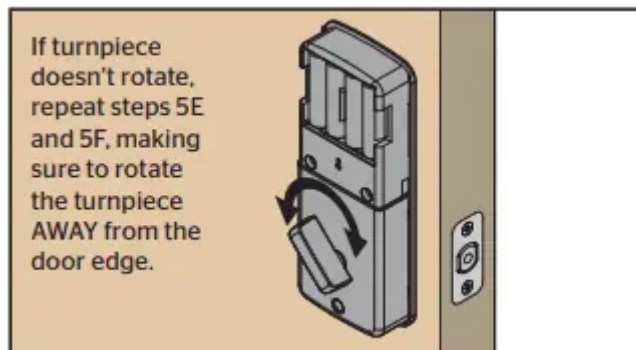

H Secure the interior assembly with the supplied screws.

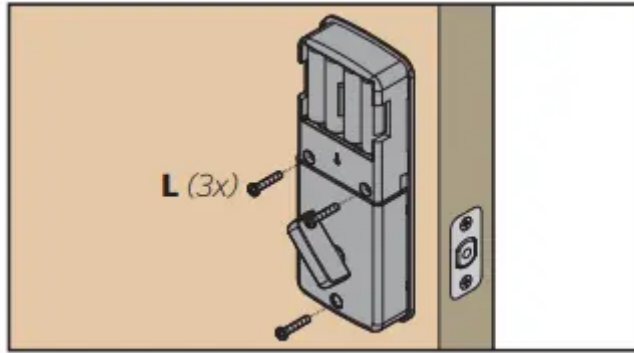

I Reinstall battery cover and make sure the latch is still in the unlocked position.

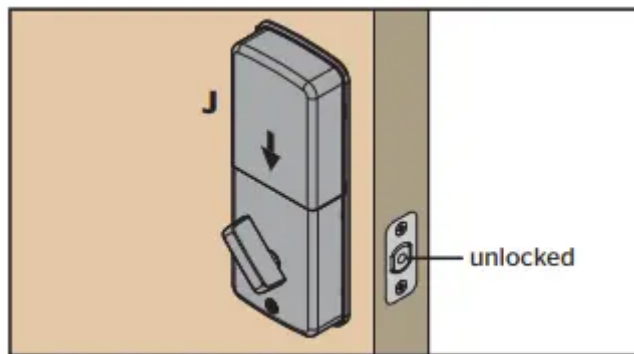

1. Enter door handing code and test lock

A While the door is OPEN and UNLOCKED, enter the following code to teach the lock the orientation of the door:

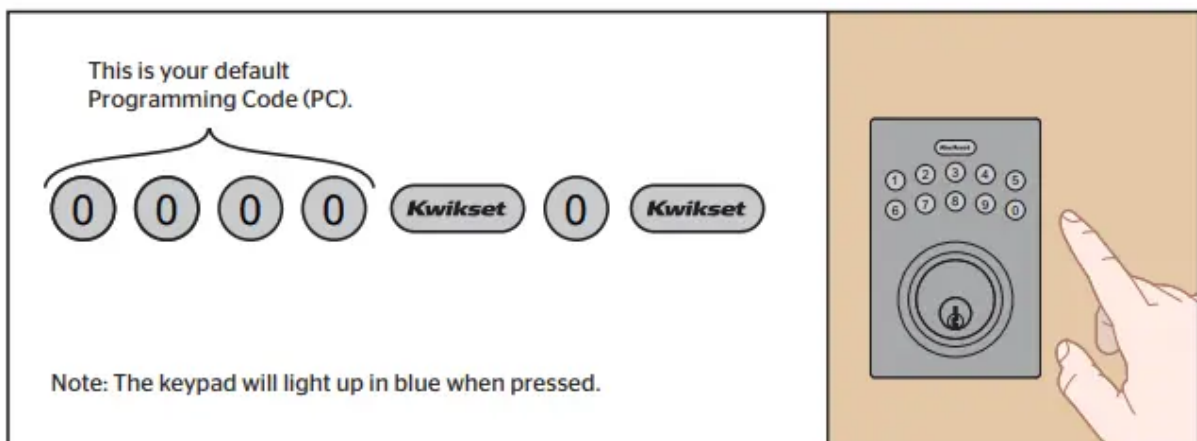

B If successful, the Kwikset button will flash green 2 times and you will hear 2 beeps. If unsuccessful, the Kwikset button will flash red 3 times, and you will hear 3 beeps

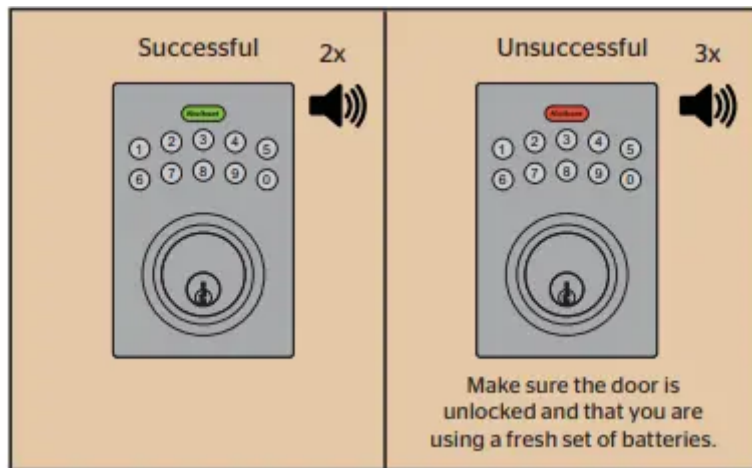

C If successful, press the Kwikset button. The latch bolt will extend to lock

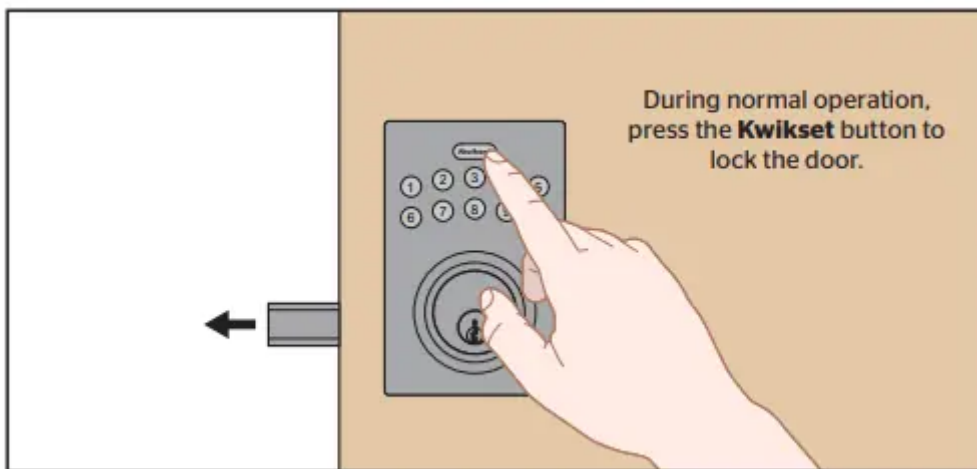

D Enter the default User Code (1-2-3-4), then press the Kwikset button. The latch bolt will unlock.

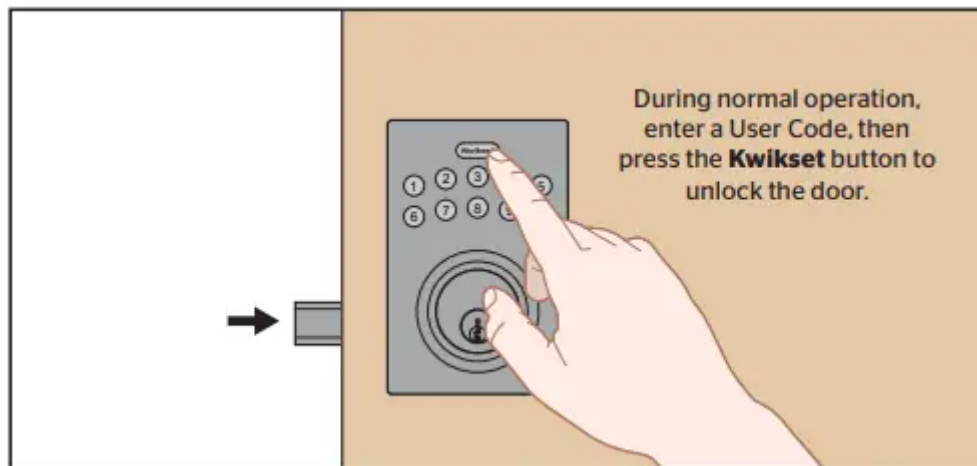

Installation is complete. It is recommended that you replace the default Programming Code and default User Code with codes of your own. See page 8.

Programming IMPORTANT:



Before any programming sequence, make sure that your door is open and unlocked. For all programming sequences below, success is indicated when the Kwikset button flashes green 2 times and you hear 2 beeps.

If unsuccessful, the Kwikset button will flash red 3 times and you will hear 3 beeps. Note: If the lock is muted, you will not hear the lock beeping.

How to change your Programming Code

The Programming Code (PC) will not unlock your door. It is an added security feature that is used to set up all functions. The default PC is 0-0-0-0. It is recommended that you change it to a code of your own.

1. Enter your existing PC.

2. Press   

3. Enter a new PC. It must be between 4 and 10 digits.

4. Press 

How to add User Codes

A total of 6 User Codes (and a temporary one-time User Code) may be programmed. Do not program a User Code that is the same as your PC.

1. Enter your PC.

2. Press   

3. Enter a new User Code. It must be between 4 and 10 digits.

4. Press 

5. Test the code: While your door is open, lock it and enter your new User Code to make sure it unlocks the door.

How to delete individual User Codes

The lock is pre-programmed with a default User Code of 1-2-3-4. It is recommended that you delete this code.

1. Enter your existing PC.

2. Press   

3. Enter the User Code you wish to delete.

4. Press 

5. Test the code: While your door is open, lock it and enter the User Code to make sure it no longer unlocks the door.

How to add a one-time User Code

A one-time user code may be used only once, and then it will be deleted immediately after use.

1. Enter your existing PC.



3. Enter a new User Code. It must be between 4 and 10 digits.



How to enable/disable User Codes

If User Codes are disabled (example: when you go on vacation), the lock can only be operated by the key and turnpiece until they are enabled again.

1. Enter your PC.



3. Repeat steps 1 and 2 to enable or disable the codes again.

How to delete all User Codes

If all User Codes are deleted, the lock can only be operated by the key and turnpiece until a new User Code is added.

1. Enter your existing PC.



How to enable/disable Auto-Lock

The Auto-Lock feature automatically re-locks your door 30 seconds after unlocking. This feature is off by default.

1. Enter your existing PC.



3. Repeat steps 1 and 2 to enable or disable Auto-Lock again.

How to change Auto-Lock time delay

You can set the Auto-Lock time delay between 10 and 99 seconds.

1. Enter your PC.

2. Press **Kwikset** **6** **Kwikset**

3. Enter time between 10 and 99 seconds.

4. Press **Kwikset**

How to mute/unmute lock

If the lock is muted, you will not hear beeping during programming, normal operation, low battery indicators or system alerts.

1. Enter your existing PC.

2. Press **Kwikset** **7** **Kwikset**

3. Repeat steps 1 and 2 to mute or unmute the lock again.

How to restore default settings

This procedure will delete all User Codes associated with the lock, and the default PC and User Code will be restored.

1. Press and hold the Reset button for 5 seconds, until you hear 3 beeps and see the Kwikset button flash amber 3 times.

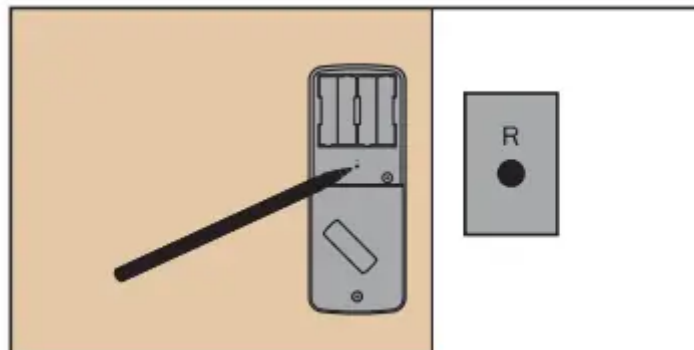

1. Enter the default PC (0-0-0-0).

2. Enter the door handing code to re-teach the lock the orientation of the door

Kwikset **0** **Kwikset**

1. Test the lock: With the door open and unlocked, press the Kwikset button to make sure it locks the door.

2. Test the default User Code: Enter the default User Code (1-2-3-4), and make sure it unlocks the door.

System Alerts

Alert	Reason	Solution
Kwikset button flashes red 3 times with 3 beeps*	Door jammed while attempting to lock	Manually re-lock door. If needed, reposition strike.
	Door handing code has not been entered	Enter door handing code. See page 7
	No User Code programmed, or User Codes are disabled	Program at least one User Code, or re-enable User Codes
	Unsuccessful programming	Attempt programming procedure again
	Incorrect User Code entered	Re-enter User Code.
Kwikset button flashes red 5 times with 5 beeps*	5 incorrect User Codes entered within one minute	Re-enter User Code after 45-second keypad lockout
Kwikset button flashes red 10 times with 10 beeps*.	Low battery.	Replace batteries.

*Beeping sound will not be heard when the lock is muted.

Regulatory Compliance

This product complies with standards established by the following regulatory bodies

- Federal Communications Commission (FCC)
- Industry Canada

This device complies with Part 15 of the FCC Rules. Operation is subject to the following two conditions:

1. this device may not cause harmful interference, and
2. this device must accept any interference received, including interference that may cause undesired operation.

This equipment has been tested and found to comply with the limits for a Class B digital device, pursuant to Part 15 of the FCC Rules. These limits are designed to provide reasonable protection against harmful interference in a residential installation. This equipment generates, uses, and can radiate radio frequency energy and, if not installed and used in accordance with the instructions,

may cause harmful interference to radio communications. However, there is no guarantee that interference will not occur in a particular installation. If this equipment does cause harmful interference to radio or television reception which can be determined by turning the equipment off and on, the user is encouraged to try to correct the interference by one or more of the following measures

- Reorient or relocate the receiving antenna.
- Increase the separation between the equipment and receiver.
- Connect the equipment into an outlet on a circuit different from that to which the receiver is connected.
- Consult the dealer or an experienced radio/TV technician for help.

IMPORTANT! Changes or modifications not expressly approved by the manufacturer could void the user's authority to operate the equipment.

Industry Canada

This device complies with Industry Canada licence exempt RSS standard(s). Operation is subject to the following two conditions: (1) this device may not cause interference, and (2) this device must accept any interference, including interference that may cause undesired operation of the device

Troubleshooting

The turnpiece cannot rotate or operate the lock.

Remove and reinstall the lock, making sure that the tailpiece is horizontal in steps 4 and 5

The lock cannot be locked or unlocked by the keypad.

Make sure the lock is programmed with at least one User Code and that the User Codes are not disabled. If needed, restore the lock's default settings. See page 9.

The keypad doesn't respond when touched (no lights are visible and no beeping is heard).

Make sure the cables are properly connected, and make sure the batteries are new and installed correctly.

After the lock has been working normally, the latch bolt locks up and the turnpiece will not rotate.

Enter your PC, then re-enter the door handing code:



The door can be locked with the Kwikset button, but the User Code will not unlock the door

Make sure the User Code is correct and that the Kwikset button is pushed after entering the User Code. If the door still won't unlock, use a key to unlock the door. Call technical support for further troubleshooting.

When the door is closed and the Kwikset button is pressed to lock the door, the lock emits a system alert. When the door is open and the Kwikset button is pressed to lock the door, there is no system alert.

Make sure that the hole in the door frame behind the strike is drilled at least 1 inch (25 mm) deep. Also make sure the strike plate is aligned with the latch bolt. If needed, reposition the strike.

Important Safeguards

- Read all instructions in their entirety.
- Familiarize yourself with all warning and caution statements.
- Remind all family members of safety precautions.
- Restrict access to your lock's interior assembly and routinely check your settings to ensure they have not been altered without your knowledge.
- Protect your User Codes and Programming Code.
- Dispose of used batteries according to local laws and regulations.

CAUTION: Prevent unauthorized entry. This lock has a pre-set User Code and Programming Code. Upon installation and set-up, replace both of these codes with your own. Since anyone with access to the interior assembly can reset the lock and change the User Codes, you must restrict access to the interior assembly and routinely check the User Codes to ensure they have not been altered without your knowledge

WARNING: This Manufacturer advises that no lock can provide complete security by itself. This lock may be defeated by forcible or technical means, or evaded by entry elsewhere on the property. No lock can substitute for caution, awareness of your environment, and common sense. Builder's hardware is available in multiple performance grades to suit the application. In order to enhance security and reduce risk, you should consult a qualified locksmith or other security professional

Warning

This content is compiled from multiple sources and is provided for reference purposes only. It may not be complete or fully applicable to all situations. If you are unable to resolve your issue, please contact the product manufacturer or an authorized service provider for official support.